



Politecnico di Torino

Porto Institutional Repository

[Article] Hydraulic Actuation System with Active Control for the Lateral Suspensions of High Speed Trains

Original Citation:

Jacazio G.; Gastaldi L.; Balossini G.; Magnani A. (2013). *Hydraulic Actuation System with Active Control for the Lateral Suspensions of High Speed Trains*. In: [INTERNATIONAL JOURNAL OF HEAVY VEHICLE SYSTEMS](#), vol. 20 n. 3, pp. 236-252. - ISSN 1744-232X

Availability:

This version is available at : <http://porto.polito.it/2507561/> since: May 2013

Publisher:

InderScience Publishers

Published version:

DOI:[10.1504/IJHVS.2013.054786](https://doi.org/10.1504/IJHVS.2013.054786)

Terms of use:

This article is made available under terms and conditions applicable to Open Access Policy Article ("Public - All rights reserved") , as described at http://porto.polito.it/terms_and_conditions.html

Porto, the institutional repository of the Politecnico di Torino, is provided by the University Library and the IT-Services. The aim is to enable open access to all the world. Please [share with us](#) how this access benefits you. Your story matters.

(Article begins on next page)

Hydraulic actuation system with active control for the lateral suspensions of high speed trains

Gualtiero Balossini

Microtecnica,
Località Bocciardino,
Luserna San Giovanni (TO) 10062, Italy
E-mail: gbalossini@microtecnica.net

Laura Gastaldi and Giovanni Jacazio*

Department of Mechanical and Aerospace Engineering,
Politecnico di Torino,
C.so Duca degli Abruzzi, 24,
Torino 10129, Italy
E-mail: laura.gastaldi@polito.it
E-mail: giovanni.jacazio@polito.it
*Corresponding author

Alberto Magnani

Alstom Ferroviaria, Via Ottavio Moreno 23,
Savigliano 12038, Italy
E-mail: alberto.magnani@transport.alstom.com

Abstract: High speed trains normally use actively controlled pneumatic systems to recentre the car body with respect to the bogie when the train negotiates a curve. Pneumatic systems are used because of their softness, which adds a little contribution to the elastic force generated by the mechanical springs of the lateral suspension system, thereby allowing the necessary dynamic isolation between car body and bogie. However, pneumatic systems have the drawbacks of large dimensions and slow response, often accompanied by a few damped oscillations. An innovative solution was developed that makes use of hydraulic actuators, providing them with artificial compliance generated by an appropriate control, hence making the hydraulic actuators suitable for this application. A car body centring system is thus obtained that presents fast response, small volume and a softness comparable to that of a pneumatic system. The optimal control law for this system was defined, the system dynamic characteristics were analysed and a technological demonstrator was built to assess the system merits. The paper outlines the theoretical grounds for the system control, its performance and the most significant results obtained during a test campaign conducted on the technological demonstrator.

Keywords: lateral suspension; high speed train; hydraulic suspension; active control.

Reference to this paper should be made as follows: Balossini, G., Gastaldi, L., Jacazio, G. and Magnani, A. (2013) 'Hydraulic actuation system with active

Biographical notes: Gualtiero Balossini graduated in Aeronautical Sciences in 1969. His ensuing career has been the following: from 1969 to 1972 in Aermacchi Varese in the Engineering Department as Customer Technical Support for MB326 aircraft systems; from 1972 to 1975 in Aeritalia, Caselle Airport, Flight Line Operation as Engine System Engineer; from 1975 to 1980 in Microtecnica Turin, in the Engineering Department, in Actuation and Engine Control Design; from 1980 to 1985 in Moretta Company Turin, as Head of the Design Department, Test Systems for Automotive and Aerospace Application; from 1985 to 1992 in Microtecnica, head of the Test System Design Department; from 1992 to 2001 in Microtecnica, Experimental Center Manager; from 2002 in Microtecnica as Plant Manager.

Laura Gastaldi graduated in Mechanical Engineering at the Politecnico di Torino in May 1993 and received her PhD in Applied Mechanics from the Politecnico di Torino in 1997. She has been a researcher in applied mechanics since 2000 and she is a lecturer and an assistant professor of Applied Mechanics in Bachelors and Masters of Science levels classes. Her research activity is related to the study of mechanical, actuation and biomedical systems' functional behaviour. Her most significant activities are focused on modelling of physiological systems, modelling and numerical simulation, digital and proportional pneumatic elements, fluid servo systems and piezoelectric drivers.

Giovanni Jacazio is Professor of Applied Mechanics at the Politecnico of Torino, Italy, where he is also a Lecturer in mechanical control systems. He received a Degree (1969) in Mechanical Engineering from the Politecnico di Torino and an MSc in Mechanical Engineering (1971) from MIT. He was appointed as a Professor of Applied Mechanics at the University of Trieste, Italy, in 1976; he then got the same position at the Politecnico di Torino in 1977. His main research activity is in the area of control and actuation systems, with particular emphasis on their aerospace and railways applications. Alongside his academic activity, he has been working as a consultant for several high tech companies, both in the aerospace and in the transport industries. He acted as a scientific consultant for the architecture definition and design of the actuation systems for several tilting trains. He is an active participant in the SAE A-6 Committee on Aerospace Actuation Control and Fluid Power Systems and a member of the Prognostics and Health Management Society.

Alberto Magnani graduated in Mechanical Engineering at the Politecnico di Torino in 1985. He joined Fiat Ferroviaria, which eventually became part of Alstom. His working experience spans over several areas relevant to the general design and testing of a train vehicle: vehicle layout study, vehicle design calculation, vehicle structural analysis, vehicle dynamic simulation, testing. In addition, he has been Leading Engineer for on-board mechanical equipment and tilting system design and train system engineer.

1 Scope of work

Car bodies of high speed trains are normally equipped with soft lateral suspensions such that the spring–mass system made up by the car body mass and the lateral suspensions springs has a frequency low enough to filter out the disturbances acting in the lateral direction, thereby improving ride quality and comfort (Andersson et al., 2007; Goodall and Kortum, 2002; Iwnicki, 2006; Persson et al., 2009). However, when the train negotiates a curve at high speed, the centrifugal force acting on the car body creates a steady force in the lateral direction as long as the train travels along the curve (Abood, 2010; Iwnicki, 2006). This steady force can exceed the forces of the lateral suspensions springs and the car body would then be laterally displaced with respect to the bogie and brought against the hard stops, hence losing the filtering action of the lateral suspensions springs and ride quality (DD ENV 12299: 1999, 1993; Goodall, 1999; Goodall and Mei, 2006).

To counteract this effect, pneumatic active lateral suspensions are normally used in high speed trains (Cho and Hedrick, 1985; Tanijfujii et al., 2002, Newland and Cassidy, 1975). These systems are based on pneumatic actuators that are subjected to a pressure differential controlled by pneumatic valves receiving electrical control signals from the train control electronics (Facchinetti et al., 2010; Sasaki, 1997).

The pressure differential command is generated by the train electronics as a function of the lateral acceleration sensed by the accelerometers such as to develop a force on the car body approximately equal and opposite to the centrifugal force. This system, which is generally referred to as pneumatic active lateral suspension, has the merit of providing the constant force necessary to recentre the car body while leaving a large lateral compliance due to the compressibility of the air. The air compliance acts as a physical filter for the disturbances created by the track irregularities (Bruni et al., 2007, Mellado et al., 2009).

While a train equipped with an active lateral suspension is travelling in a steady-state condition along a curve, the inertia force acting on the car body is transmitted to the bogie mainly through the pneumatic actuators, rather than through the mechanical lateral suspension, but in the end, the same lateral force is eventually exerted onto the wheel set, as it would be in a train without active lateral suspensions. The relatively slow response of pneumatic active lateral suspensions creates some difference with respect to a conventional train when the train is travelling on a transition curve and the lateral inertia force is progressively increasing, or decreasing (Liao et al., 2011). However, this issue has been addressed by train manufacturers and trains provided with pneumatic active lateral suspensions have been in revenue service for several years. The actual downsides of pneumatic active lateral suspension systems are: the large size of the pneumatic actuators, which creates installation difficulties in the tightly packed volume of the bogie and slow response, often associated with a few damped oscillations which create passenger discomfort.

A hydraulic active lateral suspension offers the advantages of smaller actuators size due to the much higher operating pressure and a fast and well-damped response, but its use has so far been thwarted by its inherent stiffness, which prevents the attainment of the required lateral softness. A solution capable of offering the advantages granted by a hydraulic actuation system while leaving a large lateral compliance is to control the hydraulic actuators in such a way as to obtain the force necessary to recentre the car body in a curve, but at the same time, make the controlled force independent of the car body's lateral position and speed. This control law introduces a sort of artificial compliance in the hydraulic actuation system while maintaining its responsiveness and small dimensions.

A hydraulic active lateral suspension system was hence developed, based on a closed-loop adaptive force control system in which a servovalve-controlled hydraulic actuator provides a force according to the commands received from the train electronics and this force is made little dependent on the disturbances acting on the bogie.

2 The issue of force control

Force control on a mechanical body is needed in several industrial and scientific applications and can be performed in different ways. Passive, semi-active and active systems have been used depending on the application type and on the accuracy requirements and a large variety of force control systems exists which use pneumatic, electrical and hydraulic technologies (Bishop, 2002; Viersma, 1980). Different control architectures have also been developed, ranging from simple open-loop control to complex feedback systems, depending on the required static and dynamic accuracy for the controlled force (Jacazio and Balossini, 2007, McCloy and Martin, 1980).

Whichever technology is used for developing the force, good accuracy of the force control can generally be achieved without major difficulties if the mechanical component onto which the force must be applied is either stationary, or moving at a low speed and a control law based on a conventional PID controller is normally acceptable (Bishop, 2002). However, when a controlled force must be created onto a body moving at high speed, the accuracy of the force control system can greatly worsen, unless the whole system architecture is specifically devised to compensate for the errors induced by the body movement. This is actually the case of a lateral suspension system for a train vehicle, in which track irregularities can generate lateral movements of the bogie of small amplitude, but with high speed. Data obtained from sensors placed on trains travelling along different tracks show that peak lateral speeds up to about 100 mm/s can occur; these peak speeds originate as a result of lateral movements of 5–10 mm in the 1–2 Hz frequency band. Disturbances at higher frequencies are typically associated with much lower amplitudes of lateral movements and in the end, with lower lateral speeds.

The force control system of the train lateral suspension must develop a large force, which makes in principle hydraulic actuation the most suitable technology; however, a way to artificially reduce the inherent stiffness of hydraulic control systems must be developed to make these systems suitable for their use in the train lateral suspension. The following paragraphs of this section present a discussion on hydraulic force control systems, showing the rationale that eventually led to the development of the hydraulic active lateral suspension.

A simple way to control the force developed by a hydraulic actuator is to create an open-loop control of the pressures in the two actuator chambers by means of two pressure control valves, as shown in Figure 1. These valves are equipped with an internal pressure feedback device such that the controlled pressures (p_1, p_2) are proportional to the input signals (V_1, V_2) provided by an electronic controller, but no external force control loop is created. This type of force control system has the advantage of being simple and of requiring a minimum number of components, but it does not provide good accuracy because the force developed by the actuator is not directly controlled and errors are originated by the actuator friction and inertia forces and by the pressure drops associated with the actuator movement.

Figure 1 Hydraulic force control system based on pressure control (see online version for colours)

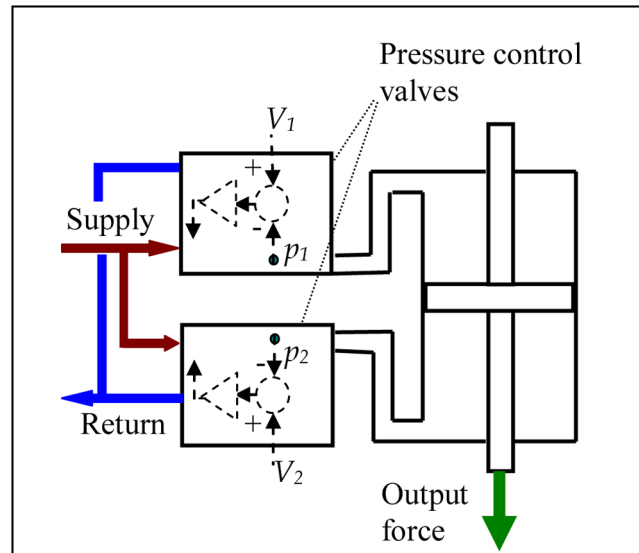

A closed loop force control system making use of a flow control servovalve and of an actuator force feedback provides a more accurate control of the actuator force. The force feedback can be obtained either by direct measurement with a load cell or by measuring the pressures in the two actuator chambers with pressure transducers, as is schematically shown in Figure 2. Such a system partly reduces accuracy errors, but it is still affected by the errors created by the actuator speed and acceleration. To understand why speed and acceleration generate an error in a force control system, reference can be made to the linearised block diagram of the system in Figure 3.

Figure 2 Hydraulic force control system based on a flow control servovalve (see online version for colours)

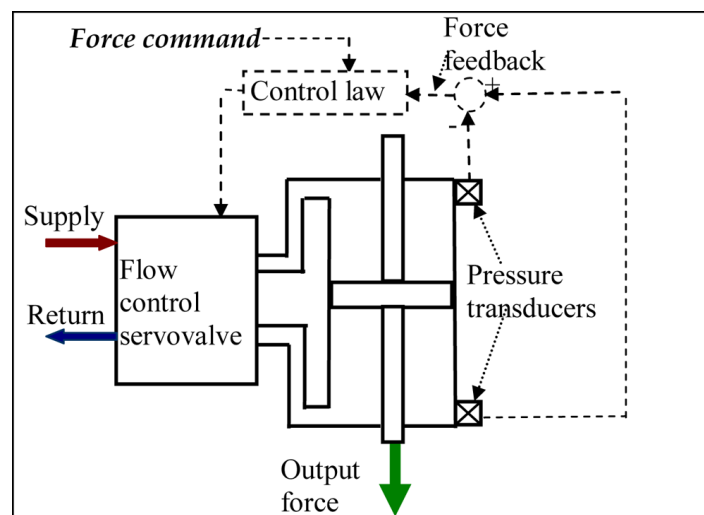
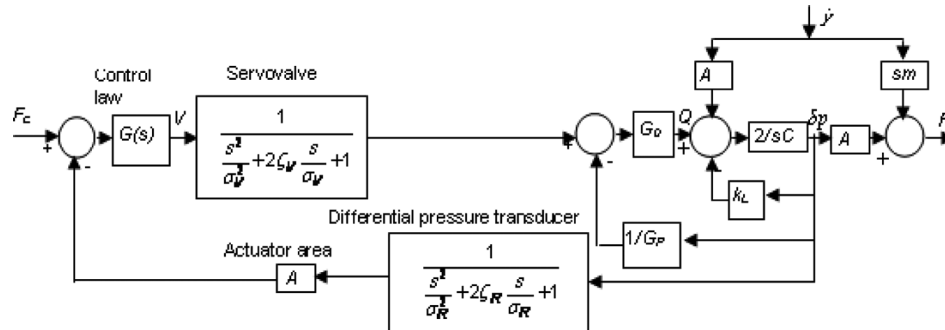

Figure 3 Linearized block diagram of a flow controlled hydraulic force control system



In the block diagram of Figure 3, F_C is the force command, F is the actual force, V is the servovalve command, Q is the servovalve flow, δp is the pressure differential between the controlled ports and y is the speed at which the actuator is driven. In the same block diagram, σ_V is the servovalve resonant frequency and ζ_V its damping factor, σ_R and ζ_R the similar quantities for the force transducer, G_Q and G_P the servovalve flow and pressure gains, A the actuator area, C the hydraulic capacitance of each actuator chamber, k_L a leakage coefficient due to the presence (if any) of a restrictor across the control lines, m the mass of the actuator piston and s the Laplace variable. Looking at this block diagram, it can be clearly seen that in a force control system, the actuator speed is a source of error; a second error source is the inertia force of the actuator piston. This contribution is nil if the speed is constant, but it can increase to a large value under rapid variations of the speed, such as would be the case for a force control system for a train lateral suspension system in which the track irregularities create continuous disturbances on the bogie as it travels along the track. Such disturbances are reflected into fluctuating lateral speed and acceleration of the bogie that are injected into the hydraulic force control system, as shown in Figure 3. To ensure good accuracy of the force control system under severe dynamic conditions, an appropriate control law was devised based on nonlinear control functions, speed and acceleration signals compensations and adaptive gains, as will be shown later in this paper.

3 Architecture of the hydraulic active lateral suspension

In the hydraulic active lateral suspension system, two double-acting hydraulic linear actuators are symmetrically placed between the bogie and the car body, as schematically shown in Figure 4; they develop the controlled force necessary to keep the car body centred with respect to the bogie.

Figure 5 shows the system schematics. The flow to the two symmetrical actuators is controlled by a four-way electrohydraulic servovalve (EHSV) accepting the control current from the electronic controller. A solenoid-operated shutoff valve enables/disables the passage of the high pressure fluid from the hydraulic supply to the servovalve supply port. When the solenoid of the shutoff valve is energised, the high pressure fluid is connected to the servovalve inlet port, thereby arming the hydraulic system; when the shutoff valve solenoid is de-energised, the servovalve inlet port becomes connected to return, hence disabling the system operation.

Figure 4 Position of the hydraulic actuators of the active lateral suspension system

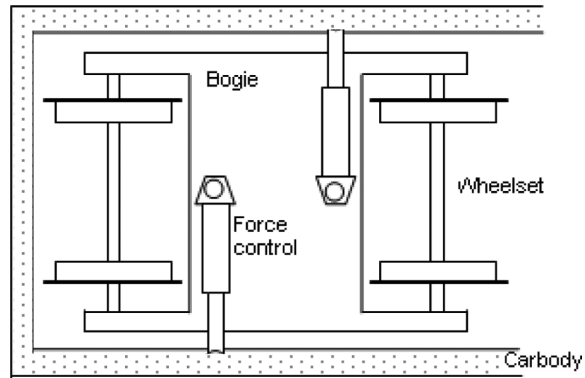
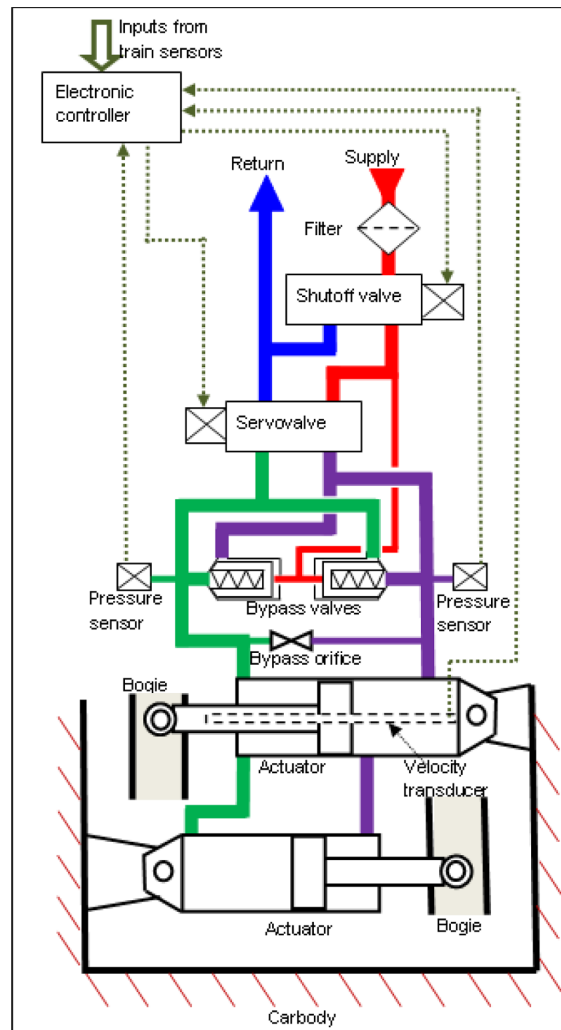

Figure 5 Hydraulic schematics of the active lateral suspension system (see online version for colours)



While energised, the shutoff valve also ports high pressure fluid to the pilot ports of two bypass valves that are thus kept closed. When the shutoff valve solenoid is de-energised, the pilot pressure of the two bypass valves becomes equal to the return pressure; these valves open, allowing a free recirculation of the hydraulic fluid between the two sides of the actuators. In these conditions, the active force control is lost, but a hydraulic lock is prevented and a mechanical decoupling between bogie and car body is attained. In addition to the bypass valves, a fixed bypass orifice is placed across the two servovalve control lines; this orifice serves a dual purpose: it introduces some physical damping into the system and it ensures that a total hydraulic lock be stymied in case the bypass valves fail to open when they should. Since the fixed bypass orifice introduces a leakage whenever a pressure differential is created across the servovalve control lines, a proper balance was made between amount of damping in the system control and leakage flow.

The pressures in the two servovalve control lines act on the piston jacks of the two hydraulic actuators, generating the controlled force in the lateral direction necessary to keep the car body centred with respect to the bogie while the train negotiates a curve and the car body is subjected to a centrifugal force. The two actuators are equal and have unbalanced thrust areas, but since they are mounted as an opposite pair, they globally act as a single balanced area actuator. The pressures in the two control lines are measured by two piezoelectric transducers whose signals are routed to the electronic controller and used to compute the force developed by the two actuators. One of the two actuators carries a velocity transducer providing a signal proportional to the relative velocity between car body and bogie, which is used by the electronic controller to generate a compensation signal for increased dynamic accuracy of the force control system.

The electronic controller accepts the input signals from the train accelerometers sensing the centripetal acceleration, computes the instantaneous lateral force required, issues the force command and closes the force feedback loop with an appropriate control law, as outlined in the following paragraphs.

4 Characteristics of the technological demonstrator

A technological demonstrator of the active hydraulic lateral suspension system was developed according to the architecture described in the previous paragraph. The demonstrator used hydraulic actuators consisting of a piston jack sliding inside a cylinder body; the nominal actuator travel was 40 mm, but the total available stroke was 260 mm to allow a large additional travel in case of system malfunction. The actuators were designed to develop a maximum force of 78,000 N (total of the two actuators). The flow control servovalve was a two-stage electrohydraulic servovalve rated for 58 l/min with 3 MPa pressure drop; its frequency response has a bandwidth of 85 Hz. The bypass orifice was sized to allow an internal leakage of 0.6 l/min with a pressure differential of 21 MPa across the servovalve control lines.

While operating, relative movements of different amplitude and frequency can take place between bogie and car body. The most critical combination of amplitude and frequency for flow consumption that can reasonably be expected in service is an oscillation of ± 20 mm at a frequency of 0.5 Hz, which leads to an average continuous flow through the actuators of 6.7 l/min. Oscillations at higher frequencies have much lower amplitudes and draw a smaller flow from the hydraulic system. When the system is not operating and the shutoff valve is

closed, the pilot pressure of the two bypass valves is equal to the return pressure and these valves open, allowing a flow recirculation between the two sides of the actuators with a minimum pressure drop. For a flow rate of 45 l/min the pressure drop created by the bypass valves is equal to 0.27 MPa. The force control loop is closed by a digital electronic controller operating with a recursion rate of 1 kHz and A/D and D/A resolution of 16 bit.

The technological demonstrator of the active hydraulic lateral suspension system was installed onto a fixture representative of the train vehicle with the following characteristics: stiffness k and damping coefficient c for the passive lateral suspension between car body and bogie were $k = 232,000$ N/m, $c = 34,000$ Ns/m; the total mass of the car body was 44,000 kg. These data are representative of the ETR480 tilting train.

5 Adaptive force control

Achieving a good accuracy in controlling the force of an active lateral suspension system in which the bogie is subjected to lateral disturbances at high frequency was possible by using a nonlinear adaptive force control law. The main challenge for the control law is to cancel out as much as possible the effects of the relative speed and acceleration between bogie and car body that act as error sources in the force control system. Figure 6 shows the block diagram of the control law developed for the hydraulic active lateral suspension system. In this diagram, s is the Laplace variable. The force control servoloop is obtained by comparing the force command F_c with the force feedback F , which is obtained by multiplying the difference between the two pressure feedback signals times the value of the combined areas A of the two actuators. The resulting force error is processed by a control block comprised of a small dead band, an integrating function G_p/s and a saturation. The small dead band is necessary to avoid limit cycle oscillations that could be originated by the combination of the actuator friction force and the integrator control function. The saturation at the integrator output is instrumental in preventing force overshoots under anomalous conditions.

Figure 6 Block diagram of the control law

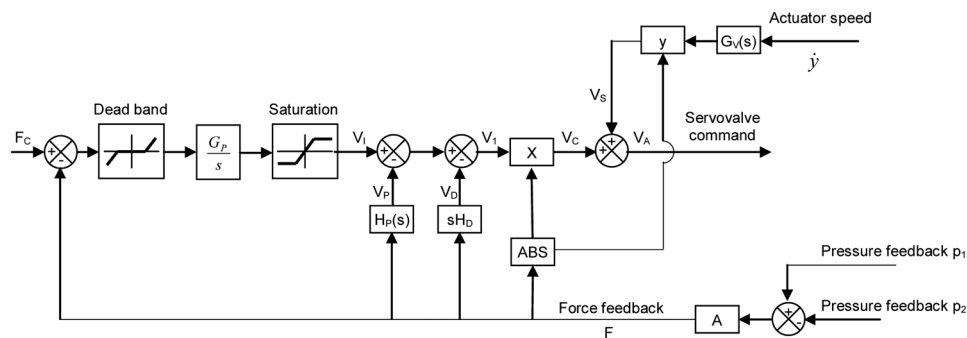

Two internal feedback signals V_p and V_D are generated from the force feedback F . V_p is a proportional feedback, since the force feedback is only slightly modified by the lag network $H_p(s)$ in which $\tau_{p3} = 3\tau_{z3}$, while V_D is a derivative feedback.

$$H_p(S) = \frac{H_p(\tau_{z3}S + 1)}{(\tau_{p3}S + 1)} \quad (1)$$

The signal V_i is proportional to the time integral of the force error and the two internal feedback signals V_p and V_d make up the core of the force control loop, but a few compensations are introduced to enable this system to attain an accurate response under severe dynamic conditions. The signal V_i resulting from the algebraic sum of V_p , V_p and V_d is multiplied by a variable gain X which is a function of the absolute value of the force feedback F . The purpose of this variable gain is to balance the nonlinear pressure-flow relationship of servovalve and bypass orifice. The value of X was computed by the following relationship, in which p_s is the system pressure, Δ a constant pressure term, k_x a load pressure coefficient and A the actuator area.

$$X = \left(\frac{p_s}{p_s + \Delta - k_x \left| \frac{F}{A} \right|} \right)^{0.5} \quad (2)$$

This nonlinear gain increases as the force developed by the actuator increases, thereby compensating the corresponding decrease of the servovalve flow gain. The control function thus becomes adaptive to the actuator force and the overall loop gain is maintained approximately constant and independent of the operating conditions.

The signal V_c out of the gain block X is then summed to the speed compensation signal V_s . As previously said in this paper and shown in the linearised block diagram of Figure 3, actuator speed and acceleration create an error source in a force control system that can become very large when actuation speed and acceleration are high. The negative effect of this error source can be limited by the closed loop force control architecture only to some extent, since the loop gain cannot be increased beyond a certain value or the system would turn unstable.

A way to minimise the error induced by actuator speed and acceleration is thus to inject a compensation signal into the forward path of the control loop, which is a function of both the speed and of its time derivative. It can be seen from the linearised block diagram of Figure 3 that the quantities proportional to the actuator speed and acceleration enter into the forward path of the control loop with a minus sign.

The control law of Figure 6, which is globally indicated as $G(s)$ in Figure 3, must then accept a compensation signal with a plus sign. This compensation signal V_s is obtained by processing the actuator speed y with the transfer function $G_v(s)$, where:

$$G_v(s) = H_s (\tau_{z5}s + 1) \quad (3)$$

Some more evidence of the effect of this compensation signal can be gained by looking at the modified linearised block diagram of Figure 7. Neglecting the higher order dynamics, if the gain H_s and the time constant τ_{z5} of the compensating transfer function are set respectively equal to:

$$H_s = A/G_Q \quad (4)$$

$$\tau_{z5} = \frac{m \left(k_L + \frac{G_Q}{G_P} \right)}{A^2} \quad (5)$$

the disturbance effects due to actuator speed and acceleration on force control are greatly reduced and dynamic accuracy is highly improved.

Figure 7 Modified linearised block diagram of a flow controlled hydraulic force control system

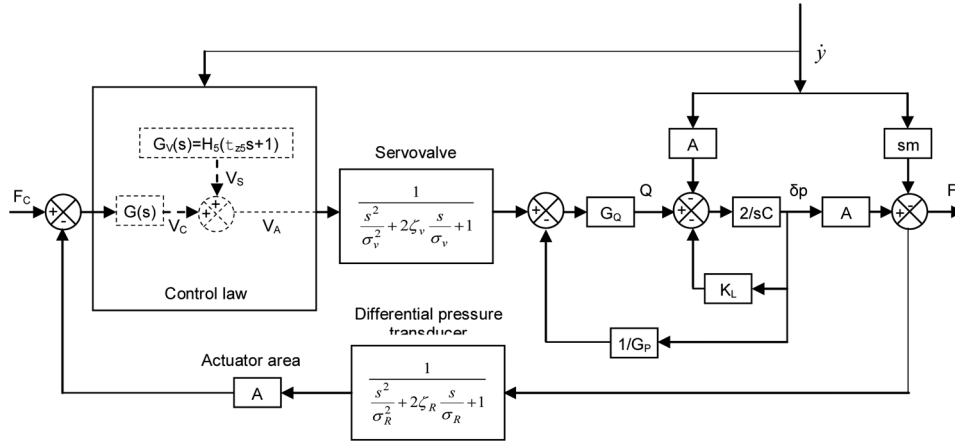

As for the control signal, the compensation signal is multiplied by a variable gain Y which is a function of the absolute value of the force F to compensate for the decrease of the system hydraulic gains with the increase of the load pressure. The value of Y was actually tuned experimentally and was set equal to:

$$Y = 1 + \left(\frac{F}{Ap_s + \Delta} \right)^{0.1} \quad (6)$$

The signal V_A resulting from the sum of the control (V_C) and speed compensation (V_S) signals makes up the input signal for the servovalve controlling the flow to the hydraulic actuators.

A linear mathematical model was used for an initial assessment of the values of the control parameters that were set to yield a phase margin of 60° and the ensuing gain margin was determined. If the gain margin turned out to be lower than 8 dB, then the control parameters were modified such as to ensure an 8 dB gain margin and to accept a larger phase margin. This procedure was performed for each of the three nested feedback loops: the external loop, the proportional feedback loop and the derivative feedback loop (Figure 6). Firstly, the control parameters were optimised for the internal derivative loop, then for the intermediate proportional loop and finally for the external loop. A subsequent tuning of the control parameter was then performed by using a nonlinear model, as outlined in the following section and a final tuning was made in the experimental phase.

6 System performance

The performance of the active hydraulic lateral suspension system was assessed both by simulations and tests conducted on the technological demonstrator. A summary of the most significant results are presented here.

The ability of the active hydraulic force control system to respond to rapidly varying force commands is highlighted by its response to ramp and sinusoidal inputs. A detailed mathematical model of the active lateral suspension system was developed for performing the system simulations, assessing the system behaviour and performing a tuning of the control parameters. The mathematical model was a physical based model in which all system components are

described by the mathematical relationships among the state variables and the physical parameters; the model was derived from other applications which proved its accuracy. This provided the necessary confidence on the simulations results. Figures 8 and 9 show the results of the simulations run for the cases of ramp and sinusoidal commands. In particular, Figure 8 shows the system response to a ramp variation of the force command from 0 (train travelling along a straight track) to 55,000 N in 1.63 s. The 55,000 N is the total of the actuators and is the force to be developed by the actuators of two bogies to balance the centrifugal force of a car body while it travels at 220 km/h along a curved track with a radius of curvature of 1,500 m. Figure 9 shows the system frequency response for an amplitude of $\pm 5,000$ N.

Figure 8 Response to a force command varying from 0 to 55000 n in 1.63 s (see online version for colours)

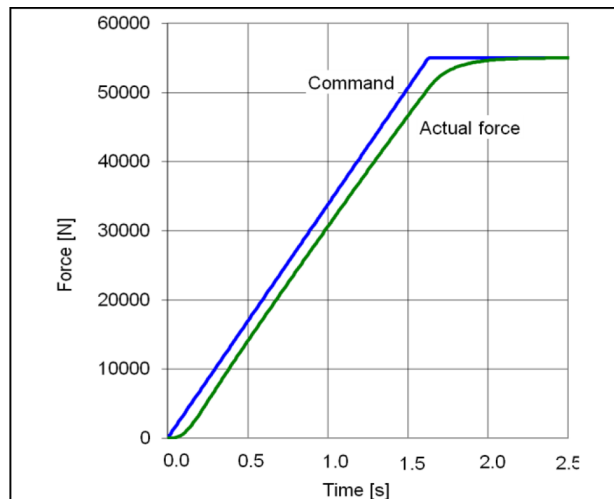
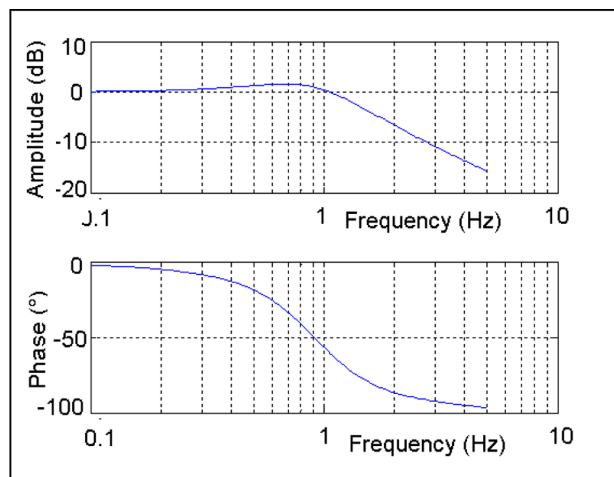

Figure 9 Frequency response of the active hydraulic lateral suspension system (see online version for colours)



The merits of the active hydraulic lateral suspension system in developing an almost constant force while subjected to lateral disturbances are highlighted by the diagrams of Figures 11–14, which are examples of the results obtained during a test campaign representative of the range of possible operating conditions occurring on a train in revenue service. The technological demonstrator consisted of an assembly in which a driving actuator is mounted in opposition to a force control actuator (Figure 10). The driving

Figure 10 Test rig for the force control system (see online version for colours)

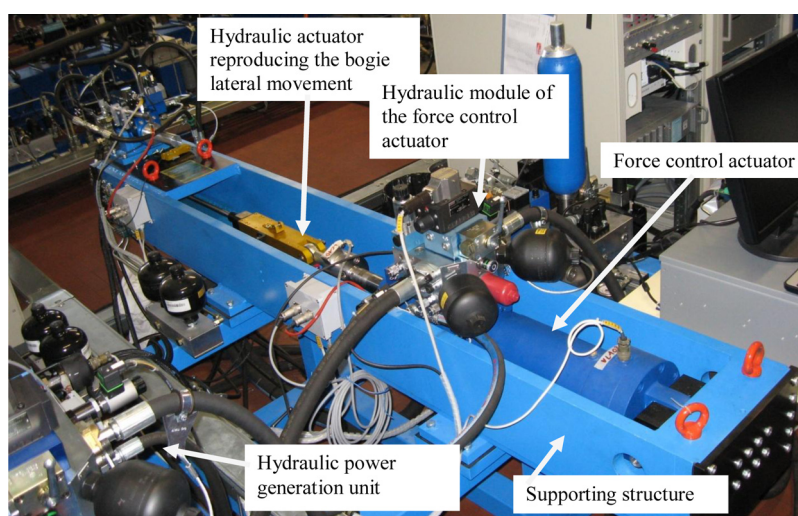

Figure 11 System response for the case of zero force command (train on a straight track) – (c) external sinusoidal disturbance relative position between bogie and car body ± 12.5 mm at 0.5 Hz and pressure differential (a) without and (b) with speed compensation

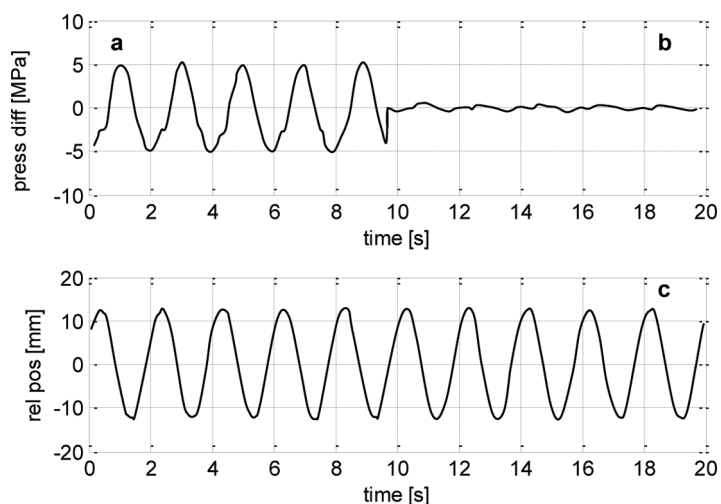

Figure 12 System response for the case of zero force command (train on a straight track) – (c) external sinusoidal disturbance relative position between bogie and car body ± 12.5 mm at 2 Hz and pressure differential (a) without and (b) with speed compensation

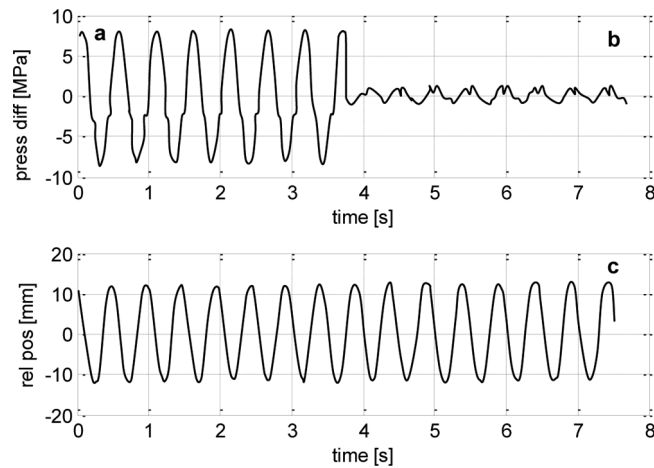
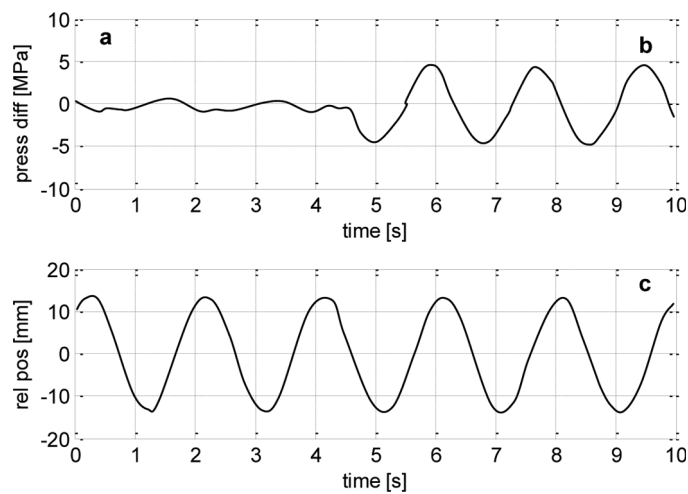
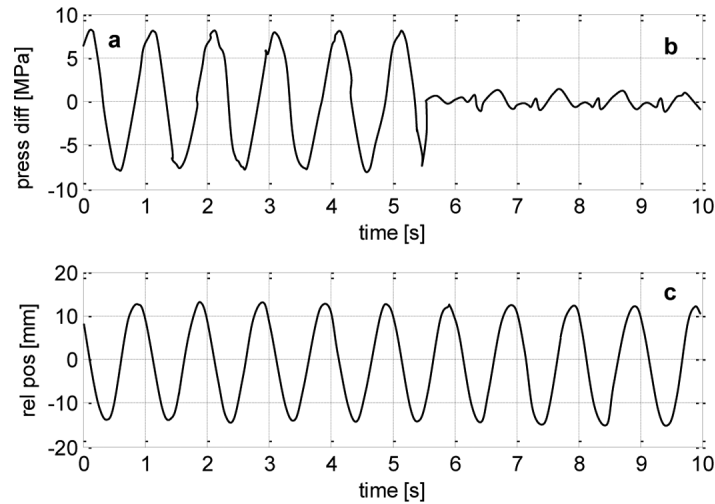

Figure 13 System response for the case of 33,000 N force command (train on a curved track) – (c) external sinusoidal disturbance relative position between bogie and car body ± 12.5 mm at 0.5 Hz and pressure differential (a) with and (b) without speed compensation



actuator is position controlled such that it reproduces the movements of the bogie, while the force control actuator develops the required controlled force. This force is applied at one end to the driving actuator representative of the bogie and at the other end to a supporting structure representative of the car body. A hydraulic module containing the valves and the interconnecting passageways is mounted onto the force control actuator. The hydraulic power supply was provided by a hydraulic power generation unit available in the lab.

Figure 14 System response for the case of 33,000 N force command (train on a curved track) – (c) external sinusoidal disturbance relative position between bogie and car body ± 12.5 mm at 1 Hz and pressure differential (a) without and (b) with speed compensation



Figures 11 and 12 refer to the case in which zero force is commanded to the active lateral suspension, which is representative of a train travelling along a straight track. Sinusoidal lateral disturbances of the bogie were injected with an amplitude of ± 12.5 mm and for two different frequencies: 0.5 Hz (Figure 11) and 2.0 Hz (Figure 12). In both cases, the merit of the speed compensation on the force control system is clear. For the 0.5 Hz frequency case, the amplitude of the pressure differential oscillations decreases by a factor of 8.3; the resulting amplitude of force oscillation on the car body is equal to 1,700 N. For the 2 Hz frequency case, the amplitude reduction of the pressure differential oscillations decreases by a factor of 7.0; the resulting amplitude of force oscillation on the car body is equal to 3,500 N.

A lower, but still very significant reduction of the amplitude of pressure differential oscillations is obtained when sinusoidal lateral disturbances of the bogie are injected while a steady state force of 33,000 N is developed by the force control system. These conditions are representative of those encountered by a train travelling along a curved track, when the active lateral suspension must counteract the centrifugal force and keep the car body centred with respect to the bogie. In particular, since the technological demonstrator was sized for a car body mass of 44,000 kg supported by two bogies, 33,000 N is the force necessary to balance the centrifugal force originated by an acceleration of 1.5 m/s^2 , which would result from a train travelling at 100 km/h along a track with 750 m radius of curvature, or at 170 km/h along a track with 1,500 m radius of curvature.

Figures 13 and 14 show again the amount of pressure differential developed between the two sides of the actuators while a sinusoidal relative movement of 12.5 mm amplitude is created. It must be emphasised that this is a very large relative movement, for it corresponds to ± 31 % of the nominal actuator travel and an external disturbance of such amplitude has to be expected at lower and hence less critical, frequencies than those used in the tests.

Figure 13 shows the results for the case of ± 12.5 mm external disturbance at 0.5 Hz; when the speed compensation is introduced, the pressure fluctuation is reduced to ± 0.75 MPa, corresponding to a residual force of 2,100 N.

Figure 14 shows the same results for the case of an external disturbance of 1 Hz; in this case, the pressure fluctuation is equal to ± 1.2 MPa, corresponding to a residual force of 3,400 N.

7 Conclusions

The work presented in this paper shows how a proper adaptive control law can create an artificial compliance in a hydraulic force control system, making it suitable for being used in the active lateral suspension of high speed trains. Such a system has the merit of providing fast response in developing the force necessary to recentre the car body of a train vehicle as it travels along a curved track at high speed, while maintaining the lateral softness necessary to ensure passengers' comfort. Analytical and experimental results encourage the use of this system on trains in revenue service.

References

- Abood, K.H.A. and Khan, R.A. (2010) 'Railway carriage model to study the influence of vertical secondary stiffness on ride comfort of railway carbody running on curved tracks', *Modern Applied Science*, Vol. 5, No. 2, pp.11–14.
- Andersson, E., Berg, M. and Stichel, S. (2007) *Rail Vehicle Dynamics*, Royal Institute of Technology (KTH), Stockholm.
- Bishop, R.H. (2002) 'Fluid power systems', *The Mechatronics Handbook*, CRC Press, Boca Raton.
- Bruni, S., Goodall, R., Mei, T.X. and Tsunashima, H. (2007) 'Control and monitoring for railway vehicle dynamics', *Vehicle System Dynamics*, Vol. 45, pp.743–779.
- Cho, D. and Hedrick, J.K. (1985) 'Pneumatic actuators for vehicle active suspension applications', *Journal of Dynamic Systems, Measurement and Control*, Vol. 107, No. 1, pp.67–72.
- DD ENV 12299: 1999 (1993) 'Railway applications ride comfort for passengers – measurement and evaluation', DK CEN TC/256 WG/7, *4th Draft Review*, Dansk Standard, Chalottenlund, Denmark.
- Facchinetti, A., Mazzola, L., Alfi, S. and Bruni, S. (2010) 'Mathematical modelling of the secondary airspring suspension in railway vehicles and its effect on safety and ride comfort', *Vehicle System Dynamics*, Vol. 48, No. 1, pp.429–449.
- Goodall, R.M. (1999) 'Tilting trains and beyond – the future for active railway suspensions, Part 1. Improving passenger comfort', *Comput. Control Eng. J.*, Vol. 10, No. 4, pp.153–160.
- Goodall, R.M. and Kortum, W. (2002) 'Mechatronic developments for railway vehicles of the future', *Control Engineering Practice*, Vol. 10, No. 8, pp.887–898.
- Goodall, R.M. and Mei, T.X. (2006) 'Advanced control and monitoring for railway vehicle suspensions', *Proceedings of International Symposium on Speed-up and Service Technology for Railway and Maglev Systems, STECH'06*, Chengdu Sichuan, P.R., China.
- Jacazio, G. and Balossini, G. (2007) 'Real-time loading actuator control for an advanced aerospace test rig', *Proceedings of the Institution of Mechanical Engineers, Part I: Journal of Systems and Control Engineering*, Vol. 221, No. 2, pp.199–210.
- Iwnicki, S. (2006) (Ed.): *Handbook of Railway Vehicle Dynamics*, Taylor and Francis, Boca Raton, Florida.
- Liao, Y., Liu, Y., Liu, J. and Yang, S. (2011) 'Effects of time delay on semi-active control for high-speed railway vehicle suspension systems', *Journal of Beijing Jiaotong University*, Vol. 35, No. 1, pp.113–118.
- McCloy, D. and Martin, H.R. (1980) *Control of Fluid Power: Analysis and Design*, Ellis Horwood, Chichester.
- Mellado, A.C., Casanueva, C., Vinolas, J. and Gimenez, J.G. (2009) 'A lateral active suspension for conventional railway bogies', *Vehicle System Dynamics*, Vol. 47, No. 1, pp.1–14.

- Newland, D.E. and Cassidy, R.J. (1975) 'Suspension and structure: some fundamental design considerations for railway vehicles', *Railw. Eng. J.*, Vol. 4, No. 2, pp.4–34.
- Persson, R., Goodall, R.M. and Sasaki, K. (2009) 'Carbody tilting – technologies and benefits', *Vehicle System Dynamics*, Vol. 47, No. 8, pp.949–981.
- Sasaki, K. (1997) 'A study of pneumatic and hydraulic active suspension of railway vehicle', *Quarterly Report of RTRI (Railway Technical Research Institute)*, Vol. 38, No. 4, pp.192–199.
- Tanifuji, K., Koizumi, S. and Shimamune, R. (2002) 'Mechatronics in Japanese rail vehicles: active and semi-active suspensions', *Control Engineering Practice*, Vol. 10, No. 9, pp.999–1004.
- Viersma, T.J. (1980) *Analysis, Synthesis and Design of Hydraulic Servosystems and Pipelines*, Elsevier, Amsterdam.

Nomenclature

A	Actuator area
c	Lateral suspension damping
C	Hydraulic capacitance of each actuator chamber
F	Controlled force
F_C	Force command
$G(s)$	General control law transfer function
$G_v(s)$	Velocity compensation transfer function
G_p	Servovalve pressure gain
G_Q	Servovalve flow gain
H_D	Derivative feedback gain
H_P	Proportional feedback gain
H_5	Velocity compensation gain
k	Lateral suspension stiffness
k_L	Leakage coefficient
k_x	Load pressure coefficient
m	Actuator piston mass
p_1, p_2	Controlled pressures
p_s	System pressure
Q	Flow rate
V_A	Corrected control signal
V_C	Control signal
V_D	Derivative feedback signal
V_I	Integrator control signal
V_P	Proportional feedback signal
V_1, V_2	Command signals
X	Variable gain multiplying factor
y	actuator position
\dot{y}	Actuator velocity
Δ	Constant pressure term
δp	Pressure differential across the actuator
σ_R	Pressure transducer filter resonant frequency
τ_{p3}	Lag time constant of the proportional feedback path
τ_{z3}	Lead time constant of the proportional feedback path
τ_{z5}	Lead time constant of the velocity compensation path
σ_v	Servovalve resonant frequency
ζ_R	Pressure transducer filter damping factor
ζ_v	Servovalve damping factor
