

# COMPARISON BETWEEN A VECTOR MULTI-PORT NETWORK ANALYZER AND THE NATIONAL S-PARAMETER MEASUREMENT SYSTEM

Andrea Ferrero (IEEE Member), Ferdinando Sanpietro, Umberto Pisani  
POLITECNICO DI TORINO, Corso Duca degli Abruzzi 24, 10129 Torino, Italy

Luciano Brunetti  
IEN Galileo Ferraris Strada delle Cacce 91, 10135 Torino, Italy

**Abstract-** A multiport vector network analyzer based on a new calibration concept, has been compared with the 2-port S-parameter National measurement system at IENGF. The measurements were performed on precision 7mm standard components and exhibited an optimum agreement. These results open the possibility to use the new multiport network analyzer for certification measurements of multiport devices.

## Summary

While 2-port NWA are commonly available and widely used by standard laboratories, an high precision test set to characterize multiport devices is not yet developed, to the authors knowledge.

A multiport S-parameter test set based on commercial instrumentation was realized by some of the authors and presented in [1].

An improved hardware of a 3-port NWA and mainly a new calibration technique, recently submitted for presentation at MTTTS-94 [2], leads this realization to be employed as multiport standard measurement system.

Figure 1 shows the basic idea of the implemented hardware, where two 4-channel frequency converters are used and phase synchronized in order to measure the six D.U.T. interesting travelling waves.

The 3-port test set calibration method, summarized as follows, requires only a good quality sliding load fitted with an APC-7mm connector and three *thru* connections:

1. thru between ports 1 and 2;
2. thru between ports 1 and 3;
3. thru between ports 2 and 3;
4. sliding load at port 1.

Since the *thru* alone can not provide information on the reference impedance value than the algorithm imposes the condition that the sliding load line characteristic impedance be the reference impedance on all ports [2, 3].

The performances of this test-set have been tested against the primary S-parameter measurement system at the IEN Galileo Ferraris. The IEN test set is based on a HP8510C and it was calibrated by TRL method [4] with the national standard 50Ω impedance in precision coaxial air-line.

Obviously, the comparison can be carried out only by measuring one or two port devices that can be connected at the 3-port system in several different test port combinations.

We report some significant results concerning APC-7mm devices like airlines, attenuators, shorts and loads. The National Laboratory adopted the following measurement procedure:

- the frequency range was chosen to assure the use of a unique line for the TRL method and to avoid 7mm connector higher modes,
- random noise was reduced by an averaging factor of 1024,
- the driving source was configured in step mode to minimize the frequency error,
- for each DUT a set of 12 measurements was performed every 300 s to quantify the overall drift error,
- the connector repeatability error was evaluated through 12 reiterated insertions of the DUT to the measurements ports.

A similar procedure was adopted for the measurements carried out with the 3-port system; furthermore each device was connected to all the 2-port pairs (ports: 1-2, 1-3, 2-3).

The IEN experimental data were statistically processed to account for system drifts and connector repeatability errors. This process gives the error bars at each measurement point which are assumed as accuracy indicator of the IEN system.

Concerning the 3-port NWA, two traces that show the spread of the overall measurements among the different port pairs, are reported on each frequency plot.

Figures 2a, 2b present the response of a nominal 10 cm coaxial airline. It is noticeable the very good agreement on the transmission parameters, while the small discrepancies concerning the reflection parameters could be related to a slide difference between the reference impedances of the two systems. The transmission parameter of a 10 dB attenuator is presented in figure 3; again the good agreement testifies that the accuracy of the 3-port system is comparable to the National Standard Laboratory one.

In conclusion this work, devoted to the metrological qualification of a 3-port test-set, demonstrates the possibility to open a new class of multiport S-parameter metrological test sets and its capability to be adopted as a standard measurement system.

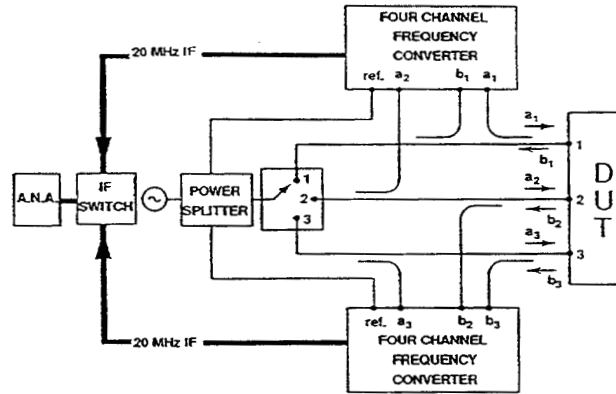

Figure 1: 3-port test set block diagram

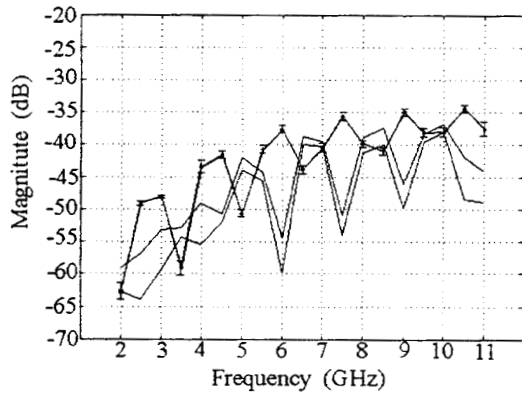

Figure 2a: 10cm air-line S11

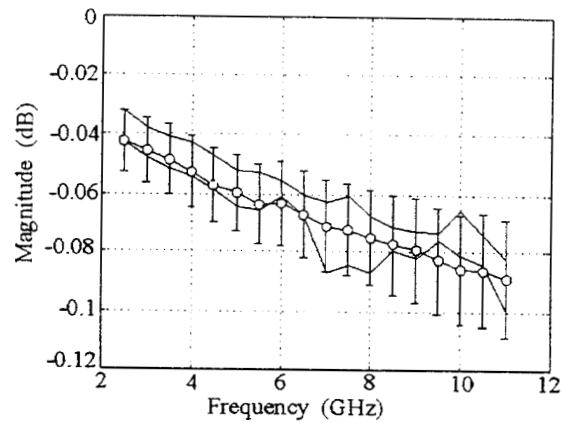

Figure 2b: 10cm air-line S21

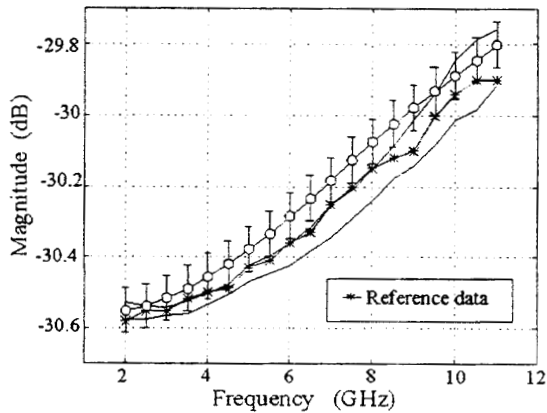

Figure 3: 30dB precision attenuator S21

## References

- [1] A. Ferrero, U. Pisani, K. Kerwin, *A new implementation of a multiport automatic network analyzer*, IEEE Trans. on Microwave Theory and Techniques, Vol. MTT-40, Nov. 1992, pp. 2078-2085.
- [2] A. Ferrero, F. Sanpietro, U. Pisani, *Accurate coaxial standard verification by multiport vector network analyzer*, submitted for the presentation at MTT-S 94, San Diego May 23-27 1994
- [3] R. B. Marks, D. Williams, *A general waveguide circuit theory*, J. Res. Natl. Inst. Stand. Technol. 97, 1992, pp.533
- [4] Engen G.F. and Hoer C.A.: *Thru-reflect-line: an improved technique for calibrating the dual Six-port Automatic network analyzer*, IEEE Trans. on Microwave Theory and Techniques, Vol. MTT-27, N.12, Dec. 1979, pp.987-993.