

LARGE SIGNAL 2nd HARMONIC ON WAFER MESFET CHARACTERIZATION

Andrea Ferrero, Umberto Pisani

Dipartimento di Elettronica

Politecnico di Torino

Cs. Duca degli Abruzzi 24, TORINO, ITALY

ABSTRACT

An automatic test set which performs a real time harmonic load-pull characterization is proposed. An active load technique is used in order to set the load at the test frequency and its harmonics and a complete set of device parameters useful for power amplifier design purposes can be measured versus the harmonic loads.

The calibration procedure, based on substrate and coaxial standards, has been mainly developed for on wafer measurement in order to set the reference planes directly on the DUT.

Introduction

The on-wafer load pull measurement presents, to respect to the conventional ones, some additional difficulties due to the presence of probes and cables between the device and the test equipment. The probes and cables losses do not allow to set high reflection coefficient if a passive tuner system is used, furthermore commercially available load pull systems give power information at coaxial levels and no informations on the harmonic behavior, which may have a strong influence when the package filtering effect is not present.

In the past a proposal to obtain a load measurement at the second harmonic, with the possibility to set such load independently from the fundamental one, was developed by Stancliff and Poulin[1] using two network analyzer test-sets, i.e. one for each harmonic frequency, and by Bosisio et al. [8] using a modified six port NWA. The first solution appears expensive especially when several harmonics are taken into account and the latter do not consider the problems of the on-wafer environment. This paper presents a solution which uses only one network analyzer system and an active load technique in order to set the harmonic load impedances with separate controls and to avoid losses problems.

By a proper calibration procedure, such parameters as the input reflection coefficient, the output load, the input and output power and the transducer gain can be measured in real time using a four channel frequency converter HP 8511A, connected to the HP 8510B network analyzer and an HP9000-300 workstation, directly at on-wafer DUT reference planes.

Some experimental results including the 2nd harmonic load influence on a $600\mu\text{m}$ MESFET will be presented.

Test-set description

The HP8340 frequency synthesizer is used as signal source which delivers the fundamental and the harmonic signals, using both the *Auxiliary output* and the *RF output*, the former directly comes from the main oscillator while the latter is obtained by internal multiplication of the main frequency.

In order to measure the loads, the fundamental and harmonic behavior of the DUT, the four channel HP8511A frequency converter is used, since it has the capability of qualifying one of the four channel as a *frequency reference*. In this way all the other channels are locked on it for the signal IF conversion and the measurement frequency of the other channels is defined from the reference one.

In the proposed test set, shown in fig. 1, we lock the *Auxiliary output* frequency and select several harmonics on the *RF output*; the *Auxiliary output* provides the fundamental frequency from 3.6 to 7 GHz, while the *RF output* delivers respectively the same frequency or the 2nd, the 3rd or the 4th harmonic, depending on the output band required.

However other multiple frequency sources can be used provided that it is possible to select the single harmonic for converter locking.

By the active load techniques, the load impedance is electronically obtained by inducing in the output line a backward traveling wave adjustable in amplitude and phase, so that it is possible to reach almost unity reflection coefficients up to the highest frequencies at on-wafer DUT reference planes overcoming the leakage problems.

In our application, two loops independently process the fundamental and second harmonic frequencies in terms of amplitude and phase and the desired reflection coefficients can be independently set by varying both the gain and the phase shift of each loop. An extension to more harmonics is straightforward by adding more loops.

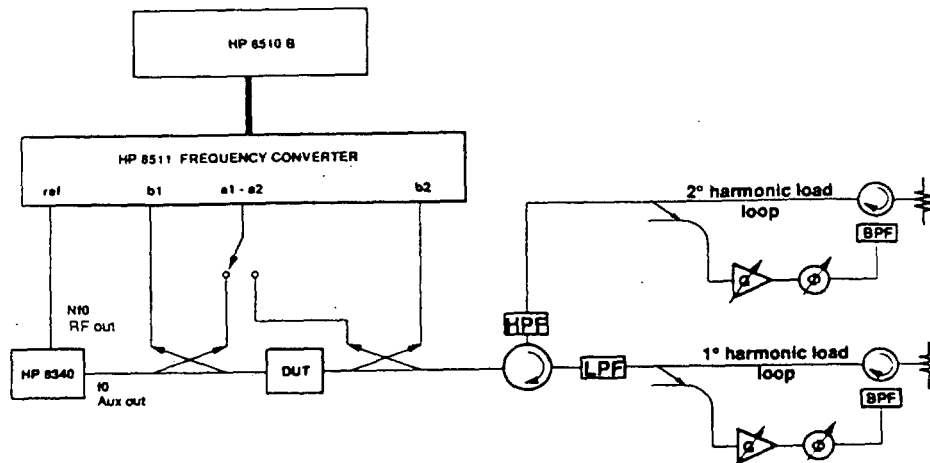

Figure 1: The test set

Calibration procedure

The set-up is calibrated by means of a purposely developed error correction algorithm, derived from the one developed by Hecht [3], performed in real time by an HP 9000-300 workstation, which governs the whole system.

Figure 2 shows the calibration steps: a SOLT calibration procedure at the input coplanar probe (section 1) is carried out by means of the standard ISS substrate supplied by Cascade (50Ω , short and open). The second step concerns the calibration of the output probe and of the dual output directional coupler in order to refer the coupled waves to the load impedance presented at the DUT reference planes (sec. 2). This is developed by putting a thru line in place of the DUT and by connecting the short, open and 50Ω coaxial standards at the end of the dual output directional coupler (sec. 3).

At last a power meter is connected at the coaxial port of the output directional coupler (sec. 3) in order to calibrate, the input power at the fundamental and the output power at all harmonics by means of single channel readings of HP8510B [6].

The developed software governs the whole system and displays on the screen all the useful parameters, such as gain, input and output reflection coefficients, the output power both at fundamental and at harmonics and the PAE in real time.

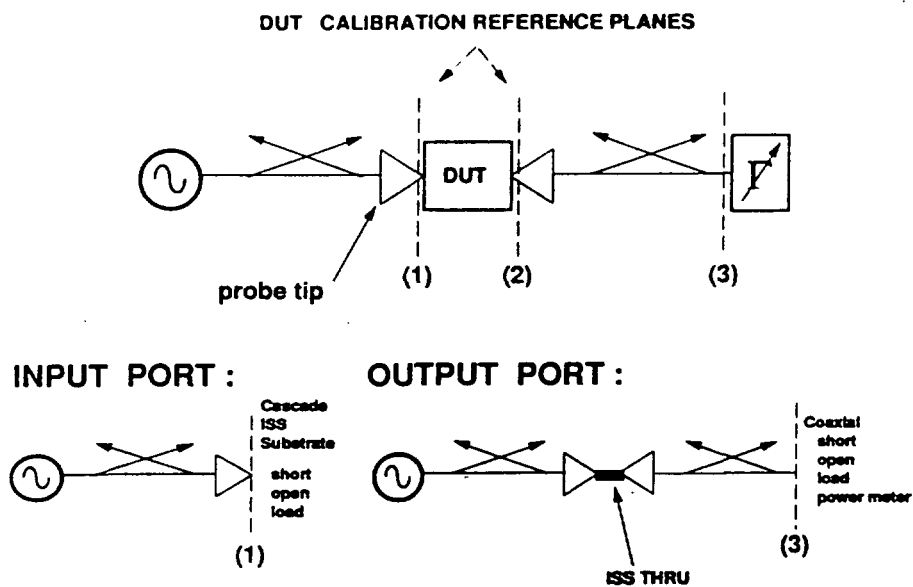

Figure 2: The Calibration procedure

Experimental results

A $600\mu\text{m}$ ion-implanted MESFET has been measured under different bias and power input conditions. The input port was kept constantly loaded on a 50 Ohm source and the input power has to be intended as the available source power.

Figure 3 and figure 4 show the Smith charts of the fundamental load plane at 4GHz for a class A operating MESFET; the first gives the usual load pull constant gain contours while the second one shows the 2nd harmonic output power constant curves. It can be seen that along the same constant gain curve, the 2nd output power can vary appreciably and of course it reaches the minimum for the load which gives the maximum gain.

Figure 5 shows the Smith chart of the 2nd harmonic load plane for the device where the load at the fundamental was kept constant for the max. Gain at 3dB of compression point. The constant power added efficiency curves vs. 2nd harmonic curves are plotted; it can be seen that the maximum of PAE is reached near the open circuit condition of the 2nd harmonic load. That seems to be in contrast with previous author results, but those were obtained with a mesfet under class B operating conditions, while we tested the DUT in class A [5].

Acknowledgments

This work was supported by Italian National Council of Research (CNR). The authors thank Telettra Company for delivering the tested devices.

References

- [1] R.B. Stancliff, D.D. Poulin, *Harmonic load pull*, IEEE Int. Microwave Symposium, 1979, pp.185-187
- [2] G.P. Bava, U. Pisani, V. Pozzolo, *Active load technique for load pull characterization at microwaves frequencies*, Electronics Lett., vol.18, 1982, pp.178-180
- [3] I. Hecht, *Improved Error-Correction Technique for Large-Signal Load-Pull Measurement*, IEEE Transaction on Microwave Theory and Techniques, vol. MTT-35, November 1987, pp.1060-1062
- [4] Y. Takayama, *A new load-pull characterization method for microwave power transistors*, IEEE MTT-S Int. micr. Symp., 1976, pp.218-220
- [5] D. M. Snider, *A Theoretical Analysis and Experimental Confirmation of the Optimally Loaded and Overdriven RF Power Amplifier*, IEEE ED-14, No. 12, December 1967
- [6] A. Ferrero, U. Pisani, *A New calibration algorithm for on wafer load pull systems*, submitted for the presentation at MTT Symposium, Boston, June 1991
- [7] A. Ferrero, U. Pisani, *A Generalized Harmonic Load Pull System*, 3rd Asian Pacific Microwave Conference, Tokio, September 1990, pp. 449-452
- [8] R. Larose, F. Ghannouchi, R. Bosisio, *A new multi-harmonic load-pull method for non linear device characterization and modeling*, IEEE MTT-S Digest, Dallas 1990, pp. 443-446
- [9] U. Lott, *Measurement of Magnitude and Phase of Harmonics Generated in Nonlinear Microwave Two-Ports*, IEEE Transaction on Microwave Theory and Techniques, vol. MTT-37, October 1989, pp.1506-1511



Andrea Ferrero has received the Electronic Engineering degree in 1987 from the Politecnico of Torino in Italy. He is currently completing his Ph.D. work in the University's Microwave Research Laboratory. His main interests are in microwave measurement techniques and device modeling.

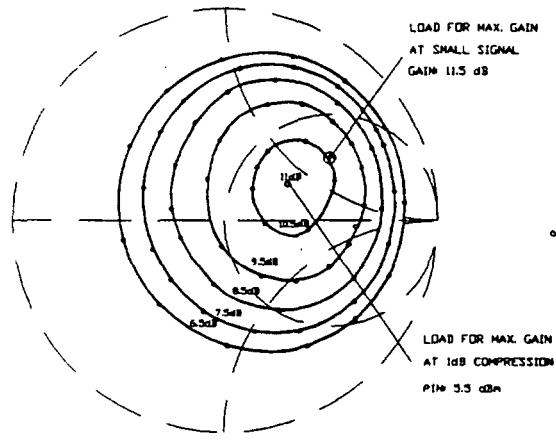

Figure 3: Costant gain curves on fundamen-
tal load plane

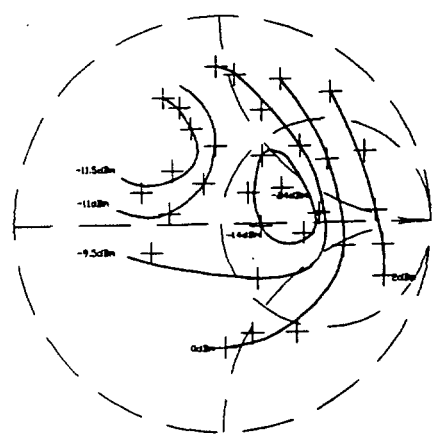

Figure 4: 2nd harmonic output
power curves vs. the load at fun-
damental frequency

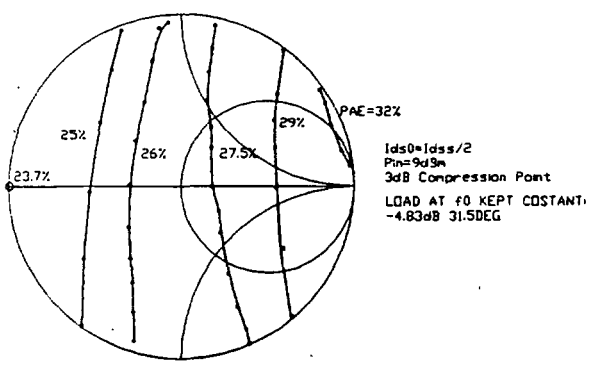

Figure 5: PAE vs. the 2nd harmonic load