



Politecnico di Torino

Porto Institutional Repository

[Article] Plastic Optical Fiber Technology for Reliable Home Networking: Overview and Results of the EU Project POF-ALL

Original Citation:

I. Mollers; D. Jager; Gaudino R.; A. Nocivelli; H. Kragl; O. Ziemann; N. Weber; T. Koonen; C. Lezzi; A. Bluschke; S. Randel (2009). *Plastic Optical Fiber Technology for Reliable Home Networking: Overview and Results of the EU Project POF-ALL*. In: [IEEE COMMUNICATIONS MAGAZINE](#), vol. 47 n. 8, pp. 58-68. - ISSN 0163-6804

Availability:

This version is available at : <http://porto.polito.it/2293352/> since: December 2009

Publisher:

IEEE

Published version:

DOI:[10.1109/MCOM.2009.5181893](https://doi.org/10.1109/MCOM.2009.5181893)

Terms of use:

This article is made available under terms and conditions applicable to Open Access Policy Article ("Public - All rights reserved") , as described at http://porto.polito.it/terms_and_conditions.html

Porto, the institutional repository of the Politecnico di Torino, is provided by the University Library and the IT-Services. The aim is to enable open access to all the world. Please [share with us](#) how this access benefits you. Your story matters.

(Article begins on next page)

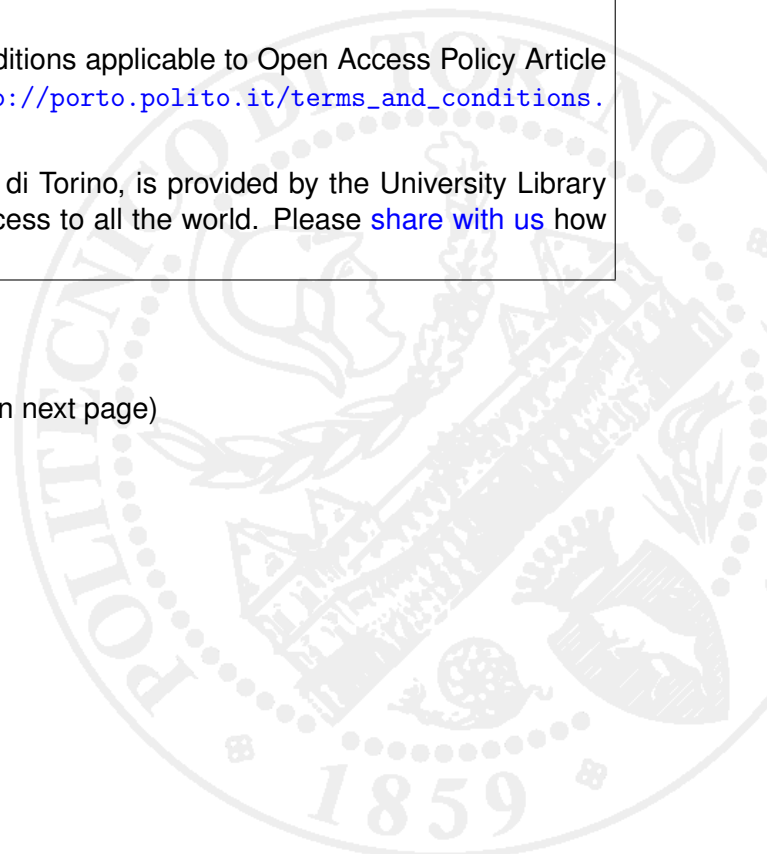

Plastic Optical Fiber Technology for Reliable Home Networking: Overview and Results of the EU Project POF-ALL

Ingo Möllers and Dieter Jäger, Universität Duisburg-Essen, Germany

Roberto Gaudino, Politecnico di Torino, Italy

Alessandro Nocivelli, Luceat S.p.A., Italy

Hans Kragl, DieMount GmbH, Germany

Olaf Ziemann, POF Application Center, Germany

Norbert Weber, Fraunhofer IIS, Germany

Ton Koonen, Eindhoven University of Technology, The Netherlands

Carlo Lezzi, Fastweb S.p.A., Italy

Andreas Bluschke, Teleconnect GmbH, Germany

Sebastian Randel, Siemens AG, Germany

ABSTRACT

The rising performance of broadband connections for residential users, particularly in conjunction with fiber to the home, will present a new challenge for telecom operators in the short and medium terms: how to deliver the high bit rate digital signals with high quality-of-service to all consumer devices scattered inside the building of final users? Among the many different solutions for the home network, we review in this article the use of polymer optical fibers for short-reach and high-capacity optical communications for residential customer premises. POF is an easy-to-install, low-cost, and eye-safe solution for these networks, with the potential of being future-proof. In this article the state of the art in POF technology is presented by summarizing significant results achieved in the European project POF-ALL. Data transmission rates of more than 1 Gb/s over 50+ m and 100 Mb/s over 200+ m of standard step-index POF have been shown.

INTRODUCTION

Optical fiber access technology (e.g., fiber to the x [FTTx]), all different flavors of very-high-speed digital subscriber line (VDSL), coaxial, and hybrid fiber coax (HFC) technologies, is carrying very high-bandwidth and high-quality-of-service (QoS) connections toward residential customers today, and in the near future will provide data rates of 100 Mb/s or higher. The development of

solutions for the very last part of this network, sometimes called the *edge network* (i.e., for short-reach access inside customer premises and individual living areas), has been mostly neglected so far but, surprisingly, may become the bottleneck of the entire communication system. Supplying QoS and always available data connection at a high data rate to the very end of the edge network (customer devices) will be a key requirement for telecom operators and service providers to successfully place their products on the market. In addition, the reliability of the network for services like Internet Protocol TV (IPTV) and video on demand (VoD) is of utmost importance to the customer, especially when high-definition video content with low packet error tolerance and low latency time is requested [1].

Besides these technical requirements, two fundamental and somewhat parallel requirements must be satisfied for these connections: low cost and extreme ease of installation. Ideally, the final customer should be able to build his/her small network inside the building, without the need for a professional installer.

Today, two approaches can be assumed for in-building networks [2]:

- *Wireless* approach: Many radio-based data transmission systems like wireless local area networks (WLANs, IEEE 802.11), Bluetooth, GSM, HSDPA, and long-term evolution (LTE) allow the user to have a finite range of mobility accompanied by a medium and inconstant data rate.

- *Wireline* approach: Unshielded twisted pair (UTP), coax, HomePNA, power line communication (PLC), optical fiber links (silica/glass single-mode, silica/glass multimode, polymer optical fibers [POFs]) provide potentially higher data rates and QoS, but no mobility.

When using a shared media approach (e.g., today's wireless, PLC, and coaxial LAN technologies), the QoS cannot be fully guaranteed without a robust medium access control (MAC) strategy, as terminals are competing for their share of the total bandwidth available. Regarding cabled solutions, UTP is still the most frequently installed solution but, with respect to rising metal prices and sensitivity to electromagnetic interference (EMI) as well as installation regulations to stay far from power lines, this solution is not ideal in home networking.

The combination of high demand in data rate and guaranteed QoS is easily met by optical communications systems, together with complete EMI immunity and no regulatory problem with coexistence in powerline ducts. Traditional silica fiber solutions could principally be used, but they need to be installed by well trained and skilled technicians, which inhibits this solution to be low-cost. For new cost-efficient installations as well as reinstallations by do-it-yourself installers, POF could be a promising solution for home networks.

The first real field installations of POF-based home networks providing triple play services (IPTV, voice over IP [VoIP], and data) for fast Ethernet have successfully been installed and tested by some telecom operators such as Swisscom [3].

While today POF transceivers are limited to relatively low bit rates (in the 100 Mb/s range), the goal for the POF-ALL project was defined to extend the limit to the gigabits per second range over several tens up to 100 m, and 100 Mb/s transmission distances to more than 200 m, respectively, by adapting higher order modulation schemes (e.g., pulse amplitude modulation [PAM] or multicarrier modulation [MCM]) and selecting suitable optoelectronic components to meet specific requirements of POF links. By demonstrating these achievements, POF-ALL will be able to show that installing POF into in-building networks would be a future-proof solution.

POF FOR SHORT-RANGE OPTICAL COMMUNICATION

POF OVERVIEW AND MARKET

Polymer or plastic optical fibers (POFs) have been largely used in industrial automation for more than 20 years in applications like PROFIBUS, INTERBUS, and SERCOS, and in harsh environments. Furthermore, POFs are deployed in millions of vehicles serving a multimedia oriented systems transport (MOST) bus with data rates of 25 Mb/s, 50 Mb/s, and 150 Mb/s (MOST150) [4]. For in-vehicle camera systems, transmission via POF in the range of 1 Gb/s is currently being studied. In recent years POF also gathered importance in consumer oriented applications like optical audio signal trans-

mission and is now challenging many coexisting technologies in the networking market.

The success of POF has been driven mainly by its technical characteristics. It is a low-cost material — standard POF is made of polymethylmethacrylate (PMMA) — and it occupies less space and weight than copper [5]. Other advantages include complete galvanic isolation and immunity to external EMI, which allows POF to be installed adjacent to copper cables in the same cable ducts or harnesses.

The main advantage of POF for these markets is that it is much easier to install than multimode glass fiber, thanks to its larger core. Standard POF has a 1 mm diameter, which allows easy fiber cutting, termination, and hence low-cost installation of the terminals. POF technology is eye-safe, and the use of visible wavelengths — the attenuation minima of POFs are in the visible region — eases the functionality check of the network.

Additionally, POF connections are extremely tolerant to residual dust on the terminal faces — a major issue, on the contrary, for glass fiber connectors. Preparing POF connections with or even without connectors, especially interesting for do-it-yourself installations in apartments, requires no more than one minute and no special tools [6].

Recent developments in POF and the telecom markets have indicated that POF is beginning to make inroads in the telecom business.

POF is enjoying significant growth in a wide range of applications due to its ease of use, large core tolerances, and low cost. It is now used in millions of small area networks, such as those in many car models, and is rapidly growing in home networks and interconnection. The POF market was estimated to be worth over US\$1.6 billion/year by the end of 2008 (Beach Communications) with an annual growth rate of more than 20 percent. According to IMS Research, the home networking market will more than double in 2009, reaching an installed base of nearly 100 million units compared to 42.5 million units in 2005.

The current home networking market has mainly been driven by the availability of broadband (> 1 Mb/s) connections to the wide area network for Internet surfing and emailing. IPTV and VoD services with future high definition content will accelerate the growth, although it is not only the connection to the Internet world that counts. Interaction between devices in the building and growing demand for intelligent home automation, control, and new lifestyle features will lead to a rapidly growing market.

Comparing the costs of POF with a still manageable amount of sold devices and fiber to current alternatives as UTP cabling, the fiber costs themselves are currently comparable to the copper-based alternative, although for the entire system much lower installation costs for POF will compensate for slightly higher cost due to the need of converters. With the perspective of growing markets for POF and demand for QoS and high data rates provided by a POF-based backbone, the costs will drop significantly. Current information regarding POF, its technology, and further information can be found in [7].

POF is enjoying significant growth in a wide range of applications due to its ease of use, large core tolerances, and low costs. It is now used in millions of small area networks, such as those in many car models, and is rapidly growing in home network and interconnection.

The technical goals are divided into the two research fields of the project: medium range and short range developments. Each field is split into one baseband and one OFDM approach, followed by a view on components and fibers.

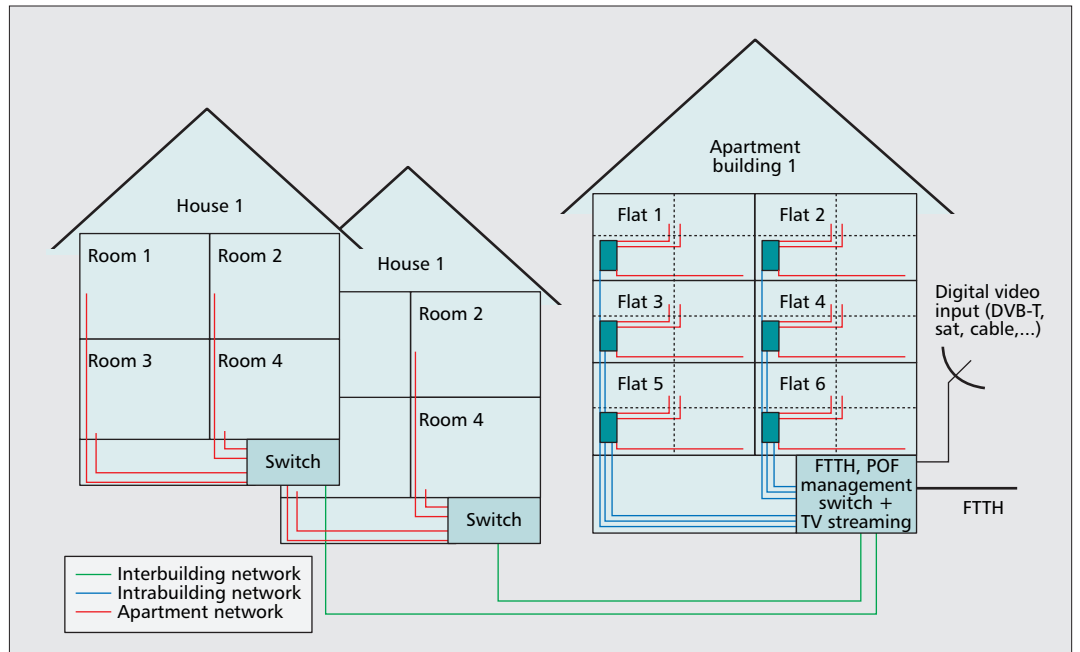

■ **Figure 1.** Definition of the edge network infrastructure (the different line colors indicate different segments of the network, see Table 1) [8].

EDGE NETWORK ARCHITECTURES

Observing international housing conditions, the home network appears to be quite heterogeneous. While a majority of North Americans live in detached houses, in Europe apartment housing is predominant, and in Asian cities multistory buildings are common. For these different needs the topology of the edge network has to be defined. Due to its capillarity, the edge network is the most expensive part of the access network. It includes interbuilding, intrabuilding, and apartment cable connections, as depicted in Fig. 1. Different POF-based solutions are suggested for different types of data transmission. The equipment for each network type must meet specific technical requirements (Table 1). Inter- and intrabuilding networks are mainly installed by telecom operators or home builders, whereas apartment networks are normally installed by private customers.

THE POF-ALL PROJECT

The Paving the Optical Future with Affordable Lightning-Fast Links (POF-ALL) project aims at developing a technology to allow delivery of 100+ Mb/s symmetrically to residential users at costs far lower than existing alternatives, thanks to the use of POF [9].

POF-ALL shall prove that POF can radically ease installation difficulties and reduce costs while providing ample bandwidth, making it an interesting alternative for edge networks. It is explicitly focused on large 1 mm core fibers based on PMMA material, in either the traditional step-index (SI-) version or the recent graded-index (GI-) version. Two main technical directions are investigated in the POF-ALL project, and results of these research activities are presented in this article:

- Medium-range transmission at 100 Mb/s (fast Ethernet) over distances above 200 m,

using standard 1 mm SI-POF, with a final target of 300 m

- Short-range transmission at high speed (1 Gb/s and more) over distance > 50 m with a target of 100 m using 1 mm SI- or GI-POF

Table 1 is a summary of the main specific attributes for the three network types and corresponding POF-based network solutions proposed within the two research fields of the POF-ALL project.

TECHNICAL GOALS AND ACHIEVEMENTS

The technical goals are divided into the two research fields of the project: medium-range and short-range developments. Each field is split into one baseband and one orthogonal frequency-division multiplexing (OFDM) approach, followed by a view of components and fibers.

MEDIUM RANGE PROGRESSION

Baseband 8-PAM Approach — Since the bandwidth length product of a standard SI-POF is currently given at around 50 MHz · 100 m [10], true binary baseband non-return-to-zero (NRZ) modulation cannot achieve data rates higher than 100 Mb/s at a distance far greater than 100 m. Consequently, multilevel baseband transmission was developed to achieve 100 Mb/s transmission over 200+ m. Due to the strong modal dispersion in 1 mm SI-POF over a distance of 300 m, the available bandwidth is on the order of around 15 MHz (maximum rates up to 28 MHz). Thus, bandwidth-efficient multilevel transmission is required. A proprietary and optimized proprietary transmission protocol based on direct baseband 8-PAM coupled with pre- and post-equalization is needed. The system that

	Specifications	POF-based solution
Interbuilding network	<ul style="list-style-type: none"> • Connections between buildings or short FTTH connections • Distance < 300 m • Data rate fixed: 100 Mb/s fast Ethernet 	<ul style="list-style-type: none"> • Transmission system based on VINAX-CPE, VDSL2 standard compliant circuit from Infineon for VDSL2 CPE applications • 520 nm POF transceiver • System price is approximately the same as the electrical VDSL2 system • The system requires high-quality POF connectors like EM-RJ or SC-RJ and professional installers.
Intra-building network	<ul style="list-style-type: none"> • Connections from building entry to the apartment entry • Distance: < 70 m • Data rate: 100 Mb/s fast Ethernet, prospective 1 Gb/s 	<ul style="list-style-type: none"> • Pluggable 470 nm simplex POF small form pluggable (SFP) transceiver and switches with 100 Mb/s SFP ports • Due to resistance of EMI, POF can use the existing ducts for electrical wires
Apartment network	<ul style="list-style-type: none"> • Connections from apartment entry to consumer device • Distance < 50 m • Data rate fixed: 1 Gb/s Ethernet 	<ul style="list-style-type: none"> • Subcarrier modulation-based transceiver • Due to resistance of EMI, POF can use the existing ducts for electrical wires

■ **Table 1.** Specifications and available POF-based solutions for edge network topologies.

has been proposed thus requires advanced digital signal processing (DSP) algorithms and is based on the following blocks (Fig. 2a):

- Conversion of the input binary data stream into 8-PAM, with (optionally) the addition of forward error correction (FEC) coding to improve transmission resilience.
- Precompensation filtering on the 8-PAM signal. This is performed by an 8-tap finite impulse response (FIR) filter with a high-pass response that partially precompensates for the bandwidth limitation of the POF channel, and an ad hoc algorithm to compensate for the LED's nonlinearity.
- Digital-to-analog conversion of the resulting signal, and application to a green (520 nm) wavelength LED with suitable driver hardware.
- At the receiver side, detection of the incoming optical signal using a high-performance PIN photodiode followed by a transimpedance amplifier and a (linear) automatic gain control circuit.
- Analog-to-digital conversion, followed by DSP-like clock recovery and blind adaptive equalization.
- Demodulation from 8-PAM to binary.

The advanced DSP proposed here is currently prototyped using a high-level field programmable gate array (FPGA). It has been demonstrated that this architecture is capable of transmitting 140 Mb/s line rate (for a net data rate equal to 100 Mb/s) over a full experimental prototype of 200 m standard SI-POF. The resulting transmission system was error-free after 200 m, showing the eye diagram represented in Fig. 2b. Additionally, a bit error rate (BER) of 10^{-3} after 275 m was obtained. Using FEC, it can be made error-free. This is a very good result that outperforms most demonstrations done in the past. It was achieved thanks to a combination of the following technical solutions that allowed the available power budget to be greatly increased:

- Use of green wavelength LED sources, where the POF attenuation is much lower than in the red region. Transmission over more than 200 m would be absolutely

impossible in the red, while in the green it gives a reasonable attenuation of approximately 20 dB.

- Improved sensitivity receiver, using the latest large area photodiodes.
- Advanced digital signal processing, including the use of FECs.

OFDM/VDSL Approach — Today, no commercial solutions are available for a highly bandwidth-efficient transmission method for SI-POF in the medium range (200+ m). The use of MCM, also called OFDM or discrete multitone (DMT), as a bandwidth-effective, noise protected, and adaptive method for transmission over SI-POF has been investigated. Following the analysis of the features of different MCM applications (number of tones, tone spacing; bits per tone; required bandwidth; possible spectral efficiency, etc.) the choice is to use existing VDSL2 as the basic technology for the required fast Ethernet transmission over 200+ m. The major feature of MCM is the division of the spectral bandwidth into several thousands of equidistant tones with a signal-to-noise ratio (SNR) depending on the number of bits modulated by quadrature amplitude modulation (QAM). With a maximal spectral efficiency of 15 b/s/Hz corresponding to 15 b/tone, VDSL2's theoretical maximum bit rate for a 17 MHz available bandwidth, 4.3125 kHz tone spacing, and 4096 tones is, as the sum for both directions, 245.76 Mb/s. For 30 MHz, with double tone spacing and 3478 tones, 417.36 Mb/s can be achieved. Furthermore, there are existing plans to transmit within a bandwidth of 35.328 MHz (8192 tones and a tone spacing of 4.3125 kHz). In this case the maximum aggregate bit rate would be 492 Mb/s.

The idea to use MCM for fast Ethernet transmission over SI-POF was proposed in [11]. In 2007 three generations of demonstrators were created. The block diagram of the demonstrator is shown in Fig. 3a. The first and second generations are based on evaluation boards from a VDSL2 chip set manufacturer. For the third generation two printed circuit boards (PCBs) were developed, one for data processing and the

Today, no commercial solutions are available for a highly bandwidth efficient transmission method for SI-POF in the medium range (200+ m). The use of Multi Carrier Modulation, also called OFDM or Discrete Multi Tone, as a bandwidth-effective, noise protected, and adaptive method for transmission over SI-POF has been investigated.

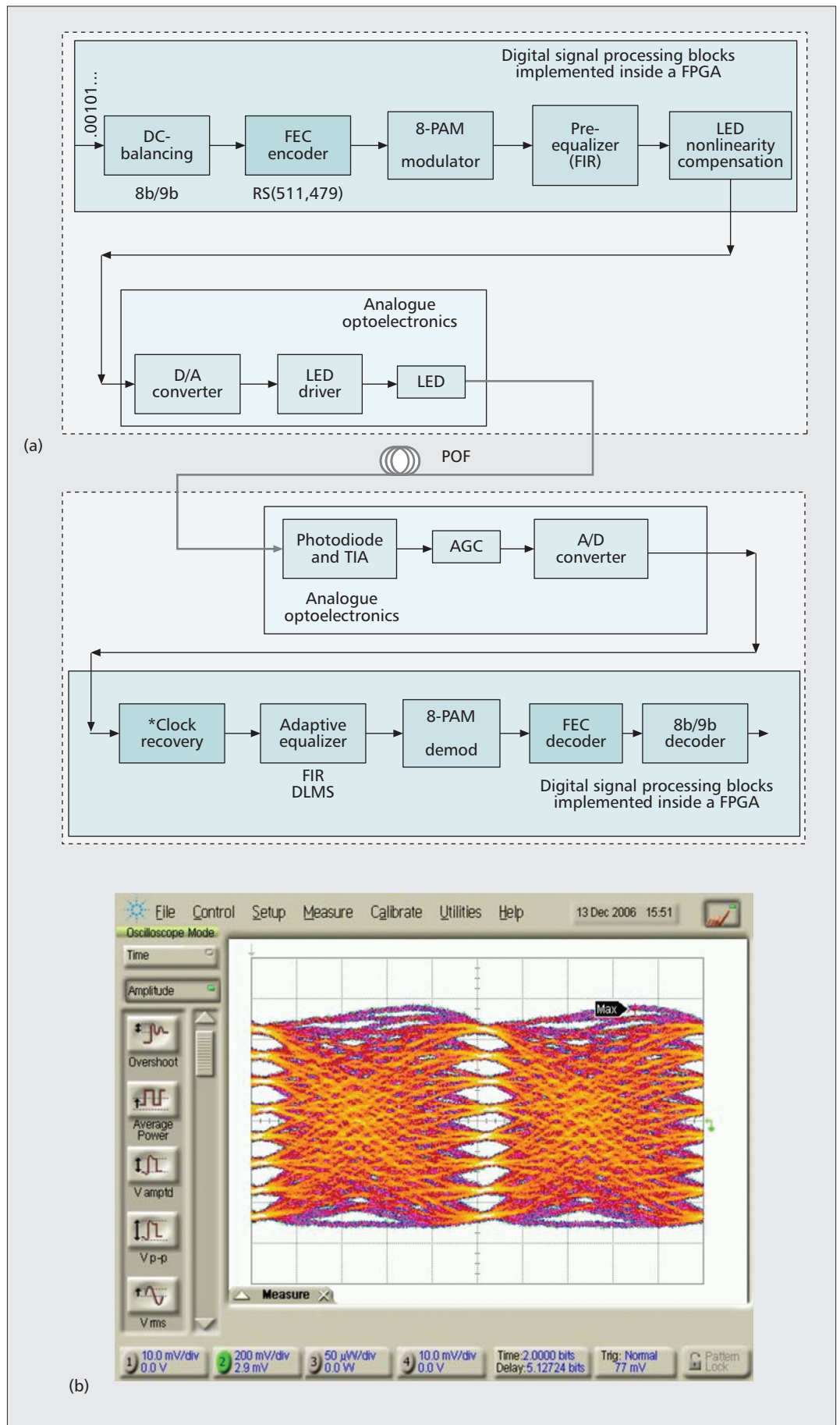

■ Figure 2. a) System setup.

As a transmitter a common red edge-emitting laser designed for DVD player applications with a 3 dB cut-off frequency well above 1 GHz is used. Even cheap devices built for DVD applications can be used for high-speed data transmission, thus taking advantage of mass-production and consequent low cost.

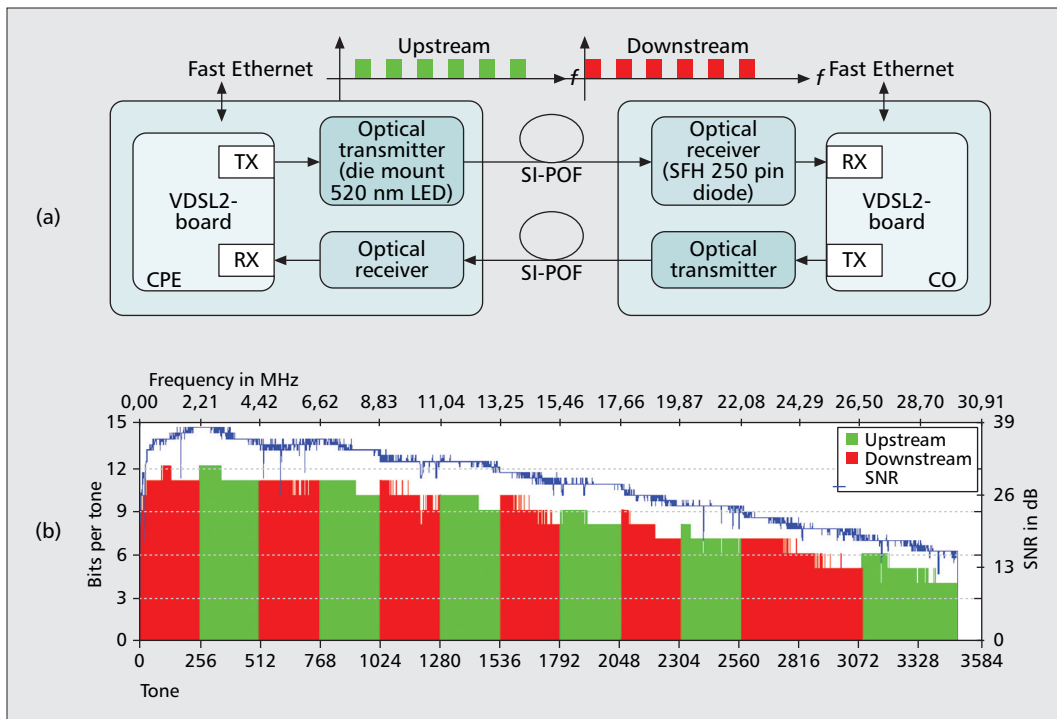

■ Figure 3. a) Block diagram of demonstrators; b) SNR and bit allocation for 200 m duplex 1 mm SI-POF.

other for the optical part. A third-generation demonstrator was built to be used in a rack with an EM-RJ optical interface. All demonstrators have been tested and were found to be fully compatible with IEEE 802.3 (100Base-T) and RFC 2544. The test results for 100 Mb/s full-duplex show an average latency of around 1.1 ms, 0 percent packet loss, and 100 percent throughput for all packet sizes.

In parallel to the practical realization of the demonstrators, theoretical investigation with the aim of finding the limits of data transmission were conducted and showed good matching with the practical results. Figure 3b presents the SNR and bit allocation for 200 m duplex SI-POF with a specially created band plan and a resulting aggregate bit rate of 216.7 Mb/s.

SHORT-RANGE PROGRESSION

Baseband Gigabits per Second Approach — Due to its exceedingly high modal dispersion, at gigabits per second bit rates the SI-POF is not easily usable, unless, as described, very advanced modulation techniques are used. As a result, in order to stick with standard binary NRZ code, a new GI-POF (the graded core refraction coefficient reduces the influence of modal dispersion) like the OM-Giga from Optimedia [5], recently released to the market, was chosen. As PMMA-based fiber it still has potential as a low-cost alternative to perfluorinated (PF-)POFs [5], and at the same time provides a much higher bandwidth length product than standard SI-POF, because of its graded index core that mainly reduces the limiting influence of modal dispersion. Using GI-POF, the problem of transmitting at gigabits per second rates is then shifted from the fiber to the optoelectronic components; the transmission system hence requires high-speed red light sources (650 nm) on the transmitter

side. Moreover, large area receivers (effective area in the 1 mm range) are necessary. Both requests are very uncommon in optical data transmission, so the main focus in this approach is on evaluating different light sources, photodiodes, and sophisticated driving concepts. As a transmitter, a common red edge-emitting laser designed for DVD player applications with a 3 dB cutoff frequency well above 1 GHz is used. Even cheap devices built for DVD applications can be used for high-speed data transmission, thus taking advantage of mass production and consequent low cost.

On the receiver side different concepts are investigated to achieve high data rates with large-area receivers. One approach is the utilization of elaborate driving concepts. These include special photodiode structures as well as low-input impedance transimpedance amplifiers and voltage upconversion to minimize capacitance and carrier drift time. The other approach is the application of concentrating optics on small-size photodiodes.

A transceiver prototype capable of 1.25 Gb/s has been realized. The transceiver fulfills not only technical guidelines, but also economical and environmental ones like eye safety, low cost, long lifetime, and the demands of mass production. The transceiver can be seen in Fig. 4, which shows a photograph of the current prototype transceivers developed inside POF-ALL. Two different small form factor gigabit transceivers are assembled, one in the typical POF SMI style (black housing) and one in an SFF style with an EM-RJ connector (silver). Today, prototypes for these transceivers are available.

First tests on a full transmission link show a sufficient eye diagram after 50 m at 1.25 Gb/s line rate, completely compatible with Gigabit Ethernet standards in terms of jitter and eye mask.

As the demand for POF systems supporting data-rates in the Gb/s range is not only growing in the home networking segment but also in the traditional POF markets automotive infotainment networks and industrial automation, the question arises whether the already deployed and widely available 1 mm SI-POF can still be used.

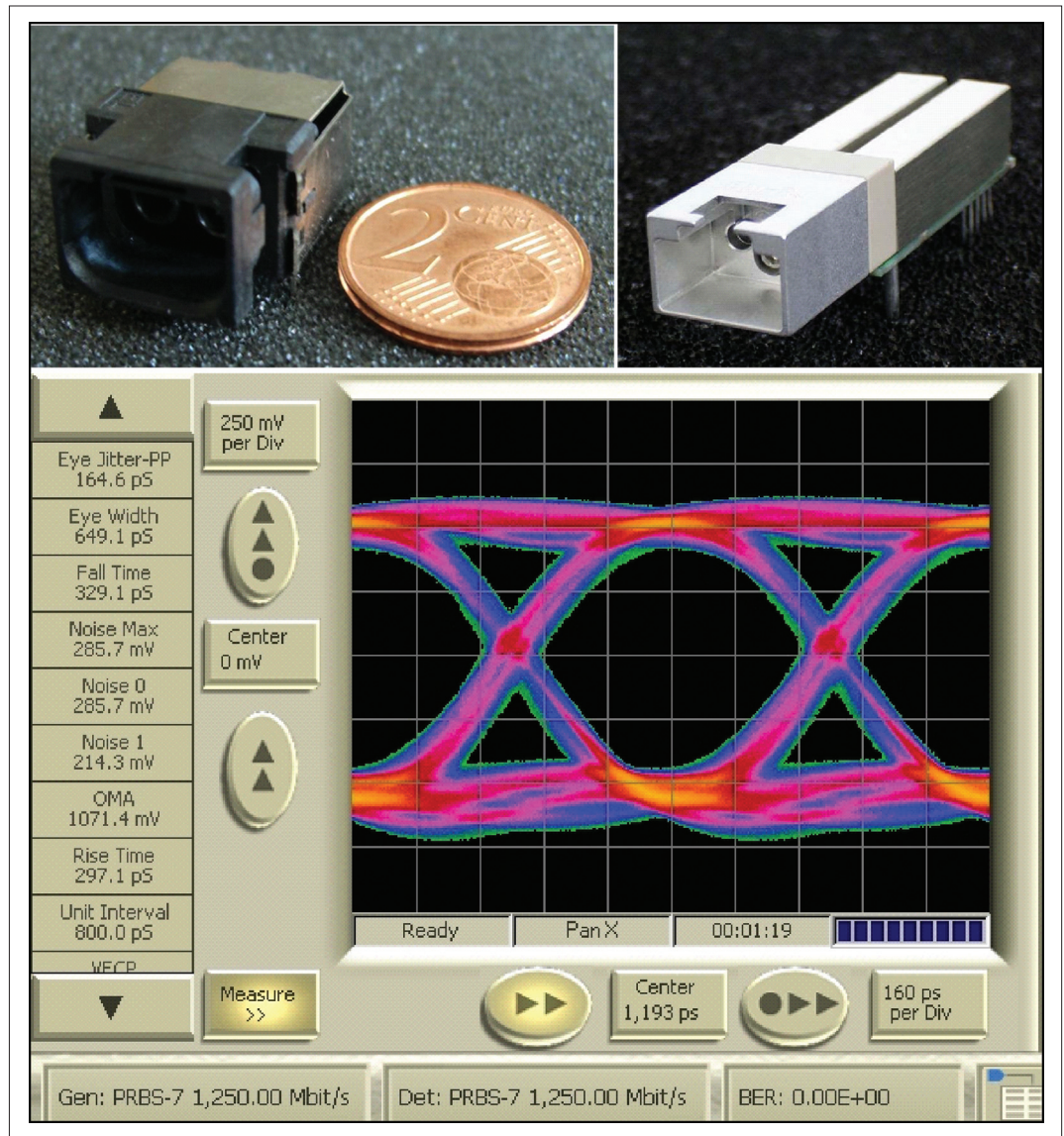

■ Figure 4. Gb/s transceiver modules and eye diagram of a 50 m GI-POF link.

OFDM Gb/s Approach — Advanced modulation formats such as PAM and DMT always add additional items to the bill of materials as they require modified analog and possibly also digital electronics [12]. Nevertheless, if the overall performance of the POF system is compared to the common NRZ modulation approach, they offer the potential for substantial benefits in terms of both cost and reliability.

As the demand for POF systems supporting data rates in the gigabits-per-second range is not only growing in the home networking segment but also in the *traditional* POF markets of automotive infotainment networks and industrial automation, the question arises of whether already deployed and widely available 1 mm SI-POF can still be used. This would obviate development, test, standardization, and installation of new fibers and cables, and therefore substantially ease their market entry. A further prerequisite for broad acceptance of gigabits-per-second systems not only in home networking is their reliability even in harsh environments, such as

temperatures above 70°C. In this respect the use of LEDs in the transmitter would be more beneficial than lasers. Furthermore, LEDs do not require monitor photodiodes for the detection of threshold drift, do not show sudden death behavior (like vertical cavity surface emitting lasers [VCSELs]), and underlie relaxed eye safety regulations.

Unfortunately, both the use of the 1 mm SI-POF for lengths in excess of approximately 10 m as well as the use of LEDs in the transmitter do not yield sufficient bandwidth for NRZ modulated data transmission at 1 Gb/s without equalization. However, recent laboratory studies have revealed that transmissions of 1 Gb/s over 100 m SI-POF can be realized by the use of a red DVD laser diode using MCM [13]. Furthermore, it has been demonstrated that advanced modulation formats such as PAM combined with decision feedback equalization as well as DMT allow transmission with data rates in excess of 1 Gb/s with an LED-based transmitter over up to 50 m standard 1 mm SI-POF.

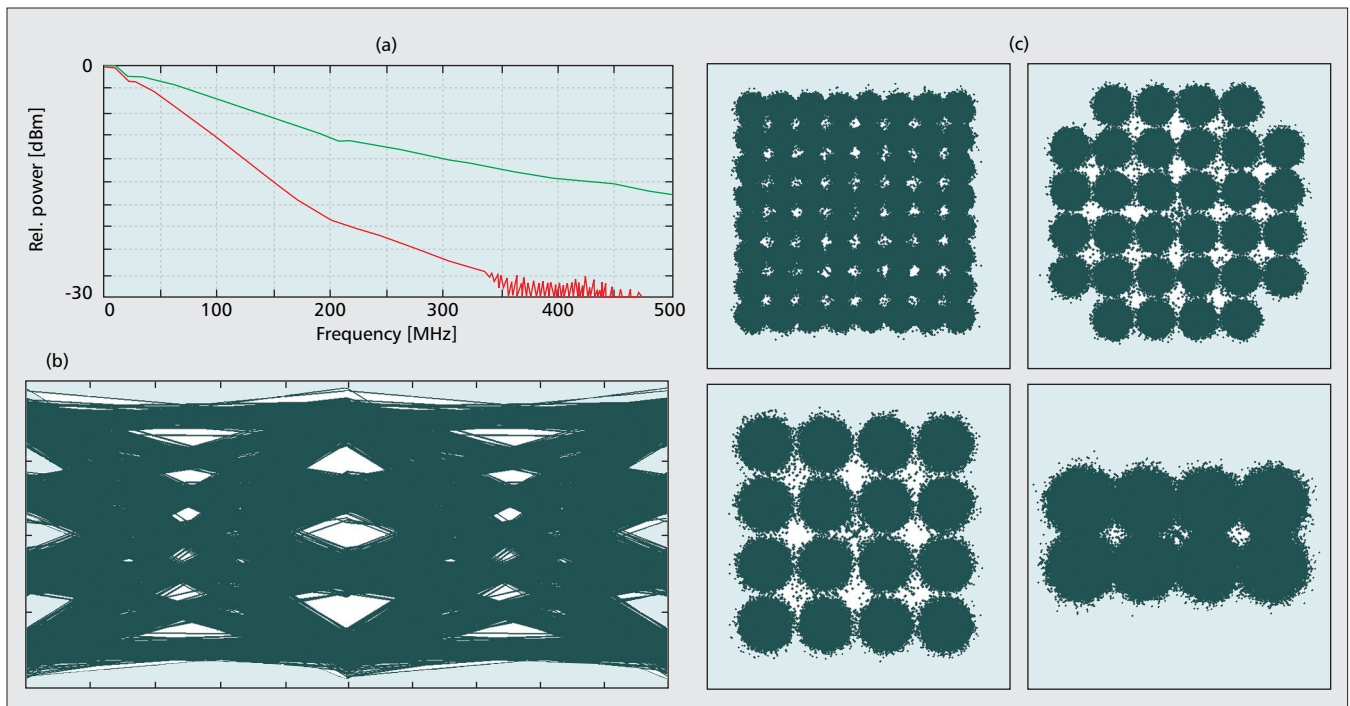

■ **Figure 5.** a) Frequency response of the transmission channel with 650 nm LED, fiber, and photo receiver for fiber lengths of 1 m (green line) and 50 m (red line); b) equalized 1.25 Gb/s 4-PAM eye diagram; c) QAM constellations of a 1.106 Gb/s DMT signal both after transmission over 50 m standard 1 mm SI-POF.

Figure 5 shows results of hardware-in-the-loop experiments employing a 650 nm resonant cavity LED with a 6 dB electrical bandwidth of approximately 150 MHz and a fiber coupled output power of -1.5 dBm at a DC bias in the range of 20 mA. The LED is driven by the output of a digital-to-analog converter continuously repeating a precalculated digital waveform. After transmission the signal is received, and the waveform is recorded with an oscilloscope. Using 4-PAM modulation combined with decision feedback equalization, a 1.25 Gb/s signal has been transmitted over a 50 m SI-POF link with a total BER of 2×10^{-5} . Using, say, a Reed-Solomon code, the data can be corrected to a BER below 10^{-12} . In a further experiment a DMT signal with 256 subcarriers was transmitted. A bit rate of 1.07 Gb/s was loaded onto the individual subcarriers according to their received SNRs. The BER was evaluated to 4×10^{-4} . Therefore, it can be concluded that advanced modulation formats offer the potential for reliable gigabits-per-second short-range POF systems at overall low system cost.

For all transmission lengths and data rates, we experimentally verified that there is negligible penalty coming from modal noise, speckle pattern, and mode partition noise. While these effects are significant in glass multimode fiber, they are irrelevant for large core POF. Moreover, it can be advantageous to use large core fibers, because modal noise is being reduced for a given aperture or cross-section mismatch in a fiber-fiber coupling. The modal noise variance decreases with the number of guided modes, which is in the range of some millions for a 1 mm SI-POF.

COMPONENTS AND FIBERS

For system development with the best possible performance, a high number of components and fibers were investigated. For low-speed (100 Mb/s) transmission over large distance (200+ m) using advanced modulation schemes the main focus is the power budget of the transmission link. Likewise, high linearity is required in order to avoid intersymbol interference and provide equal distances of signal levels in a multilevel signal. For high-speed transmission a large bandwidth must be achieved while dealing with a fiber with large diameter and high numerical aperture.

Optical sources for low-speed transmission with a focus on LEDs have been identified to best fulfill the requirements with the following characteristics:

- Green emission wavelength (lowest POF attenuation)
- Output power coupled into the fiber above 0 dBm
- Small signal bandwidth close to at least 30 MHz
- Nonlinearity control

Suitable LEDs have been investigated in great detail, and a special LED, originally produced for illumination purposes by OSRAM, has been identified to deliver the best performance. Investigating the LED's nonlinearity, only a few selected LEDs among those commercially available in the optoelectronic market are suitable for medium-range applications and have therefore been used throughout the project. For mass market POF transmitter production the design of these LEDs has to be especially adapted to data transmission applications by reducing its serial resistance in order to achieve acceptable rate of yield.

Recently, POF technology research teams are focusing on giving suggestions to international standardization bodies in order to fit the higher level POF qualities that are already available to a tightened standard for SI-POF. Today, POF are specified into 8 different classes in the IEC 60793-2-40 standard.

For short-range high-speed transmission (1 Gb/s) a variety of laser sources have been investigated with respect to bandwidth, laser power, reliability, and cost aspects. A red edge-emitting laser seems to be the most promising device for gigabit-per-second transmission over PMMA-based POF. Red VCSELs might be interesting in future applications, but still the temperature behavior and lifetime are open issues.

Additionally, investigations have been carried out for the optical receivers also addressing the two main research topics. High sensitivity was the main requirement for medium-range transmissions, whereas high bandwidth was required for short-range communications. For low-speed high-sensitivity applications, special coupling optics have been developed that are especially effective with small-size photodiodes. However, the use of large-area photodiodes is also possible for low-speed applications, and coupling optics are not necessary to achieve good sensitivity.

For designing commercial products with specifications on transmission performance, besides optoelectronic devices, the requirements of the transmission path (the fiber) must be defined. Various commercial off-the-shelf SI-POF (Mitsubishi, Toray, Ashai, Luceat) and GI-POF (Optimedia) were tested with respect of attenuation for various wavelengths, bandwidth length products, and bending losses. It has been agreed to set the following values as minimum requirements for standard SI-POF 1 mm core diameter PMMA fibers:

- **Attenuation:**
 - < 160 dB/km @ 650 nm \pm 10 nm
 - < 90 dB/km @ 510 nm \pm 20 nm
- **Bandwidth length product:**
 - > 40 MHz · 100 m @ 650 nm (max. Luceat 56 MHz · 100 m, 28.3 MHz · 300 m, respectively)
- **Bending loss:**
 - < 0.5 dB @ 25 mm bending radius

In order to place products in the POF market, the fiber specifications must be internationally standardized. In the next chapter the current status and activities in standardization for POF are addressed.

STANDARDIZATION

Recently, POF technology research teams are focusing on giving suggestions to international standardization bodies in order to fit the higher-level POF qualities that are already available to a tightened standard for SI-POF. Today, POFs are specified into eight different classes in the IEC 60793-2-40 standard [14]. Classes A4a to A4c describe the step index type PMMA-based POF. The 1000 μ m diameter includes the most frequently used POF, for example, in car networks (MOST, Byteflight, D2B, IDB 1394), in automation, and in home networking (IEEE 1394, fast Ethernet). The 500 μ m POF is mainly used in some sensor applications and fiber ribbon cables. The 750 μ m POF is only used in some special applications.

The class A4d describes a step index fiber with reduced numerical aperture (0.30 ± 0.05 or 0.25 ± 0.07 in different versions). In fact, a low-NA fiber (only one optical cladding) will only

allow minimum bending radii of about 50–70 mm, which is not acceptable in real-life applications. On this account the main POF manufacturers developed double step index profile POF (offered again as low-NA-POF) in 1995 (at this time specifically for the ATM Forum specification for 155 Mb/s). The main differences of the specified values of A4d to the actual A4a are reduced loss in equilibrium mode distribution (EMD) conditions (180 dB/km compared to the former 300 dB/km) and a 10 times greater bandwidth length product (100 MHz · 100 m compared with 10 MHz · 100 m).

The standard does not exclusively include fibers for data communication applications; class A4a also covers POF for illumination and other short-distance applications (e.g., sensors). Due to this fact the values for attenuation and bandwidth are far away from the currently reachable higher quality values. A4a specifies a group for all kinds of 1 mm POF with also poor performance characteristics, so the IEC proposed A4d as standard for data communications.

This was in total contrast to the goal of the POF-ALL project, which was focused on the standard POF A4a. Currently the standardization bodies are still studying the affiliation of a second A4a.2 standard for data communications with POF, including a value for the fiber attenuation below 180 dB/km @ 650 nm. The IEC was asked to consider and include the green and blue windows (\sim 510 nm and \sim 460 nm) with even lower attenuation in SI-POFs. Transceiver devices serving this range are already available and sold by partners of the consortium.

CONCLUSION

We have reviewed the potential impact of polymer optical fiber technologies in next-generation home networks, showing the advantages this optical media can offer with respect to competing technologies in this sector. In particular, we showed the most recent technical approaches and results of the POF-ALL project. With the goal of pushing the boundaries of large core POF links for short- and medium-range digital data transmission we found that multilevel (plus multitone) techniques have shown to be very powerful for realizing capacities beyond Gb/s in highly dispersive POF links. Due to the efficient adaptation to the frequency-dependent transfer function of the POF link, multicarrier modulation or, in particular, the OFDM technique currently provides the best solution for both medium- and short-range data transmission. Best results include 100 Mb/s transmission over 200 m of standard SI-PMMA-POF, and 1 Gb/s transmission over 50 m of SI- and GI-PMMA-POF. The first result (100 Mb/s) can find potential application in inter- and intrabuilding application where a fast Ethernet signal is to be delivered, for instance, from an active switch placed in the basement of a large residential building to each individual apartment. The second result (1 Gb/s over 50+ m) can be very interesting in very-short-reach links inside an apartment or a single-family house, such as for next-generation high-definition digital TV connections (e.g., recently announced Super HD 4K digital video).

The POF-ALL project has thus paved a long-term perspective for POF inside the residential building, showing gigabit-per-second solutions that should fulfill any reasonable requirement of residential customers even in the future.

ACKNOWLEDGMENT

This work was supported by the European Commission (EC) in the Framework Programme 6, Information Society Technologies, Specific Targeted Research Project (STReP no.: 27549) POF-ALL (Paving the Optical Future with Affordable Lightning-Fast Links).

REFERENCES

- [1] FiberSystems Europe, "Consumers Wire Up Their Home with POF," Dec. 2007/Jan. 2008.
- [2] R. Gaudino *et al.*, "Future Internet in Home Networks: Towards Optical Solutions?," chapter in *Towards the Future Internet*, G. Tselentis *et al.*, Eds., IOS Press, 2009, pp. 160–72.
- [3] H. Hirscher, "Triple Play Realization of Swisscom with POF," *16th Int'l. Conf. Polymer Optical Fiber*, Turin, Italy, Sept. 2007.
- [4] MOST; <http://www.mostcooperation.com>
- [5] O. Ziemann *et al.*, *POF-Handbook — Optical Short Range Transmission Systems*, Springer, 2008.
- [6] P. Polishuk, "Plastic Optical Fibers Branch Out," *IEEE Commun. Mag.*, vol. 44, no. 9, Sept. 2006.
- [7] POF-atlas; <http://www.pof-atlas.de>, My POF; <http://www.my-pof.de>, Plastic Optical Fiber Trade Organization; <http://www.pofto.com>
- [8] H. Kragl, A. Bluschke, and O. Ziemann, "POF Data Link Applications in the Field of Local Access Networks," *16th Int'l. Conf. Polymer Optical Fiber*, Turin, Italy, Sept. 2007.
- [9] POF-ALL; <http://www.ist-pof-all.org>
- [10] D. Cárdenas *et al.*, "A Media Converter Prototype for 10Mb/s Ethernet Transmission over 425m of Large Core Step Index Polymer Optical Fiber," *IEEE J. Lightwave Tech.*, Dec. 2006.
- [11] R. Gaudino *et al.*, "On the Ultimate Capacity of SI-POF Links and the Use of OFDM: Recent Results from the POF-ALL Project," *16th Int'l. Conf. Polymer Optical Fiber*, Turin, Italy, Sept. 2007.
- [12] S. Randel, F. Breyer, and J. Lee, "High Speed Transmission over Multimode Optical Fibers," *Int'l. Conf. Optical Fiber Commun.*, San Diego, CA, 2008.
- [13] S. Randel *et al.*, "1 Gbit/s Transmission with 6.3 bit/s/Hz Spectral Efficiency in a 100 m Standard 1 mm Step-Index Plastic Optical Fibre Link Using Adaptive Multiple Sub-Carrier Modulation," *ECOC 2006*, Cannes, France, Sept. 2006.
- [14] IEC; <http://www.iec.ch>

BIOGRAPHIES

INGO MÖLLERS [S'06] (ingo.moellers@uni-due.de) received a Diplom-Ingenieur degree in electrical engineering at the Universität Dortmund in 2005. The graduation main topics were designing and researching MOEMS for optical switching and developing high-temperature-stable polymer-based optical interconnects in printed circuit boards. Since 2006 he is a staff member and Ph.D. student at the Centre for Semiconductor Technology and Optoelectronics at the Universität Duisburg-Essen, Germany. His research interests are medium- and short-haul optical communication systems for multimode silica and polymer optical fibers, optoelectronic transceiver development and construction, radio-over-fiber technologies and system design. He is a student member of the IEEE Photonics Society (LEOS) and a member of the VDE.

ROBERTO GAUDINO [M] (roberto.gaudino@polito.it), Ph.D., is currently an associate professor in the Optical Communication Group at Politecnico di Torino, Italy, where he works on several research topics related to optical communications. His main research interest started in metro and long-haul DWDM systems, fiber nonlinearity, modeling of optical communication systems, and the experimental implementation of optical networks. Since 1998 he spent two years with a team that coordinated the development of the commercial optical system simulation software Opt-

Sim. Currently, he has moved on to optical short-reach transmission technologies. He is author or co-author of more than 80 papers in the field of optical fiber transmission and optical networks, is continuously involved in consulting for several companies in the optical sector, and is also involved in professional continuing education. He is the coordinator of the EU STReP project POF-ALL and WP leader in the EU Network of Excellence E-PhotonOne+.

ALESSANDRO NOCIVELLI (alessandro.nocivelli@luceat.it) started his working experience at Thomson CSF-LCR in France, where he developed the first European optical regenerative memory. He then moved to Air Liquide Electronics (France), where he cooperated with senior management and re-engineered the activity. In 1996 he founded Noptronics Limited, United Kingdom, and applied for patenting of a proprietary scheme for an accordable optoelectronic filter. In 2000 he founded Luceat S.p.A. (Italy), a company focused on plastic optical fiber transmission systems, which he presently leads as CEO.

HANS KRAGL (hans.kragl@diemount.com) received a Dipl.-Ing. degree in 1983 from the University of Karlsruhe and a Dr.-Ing. degree in 1988 from the Technical University of Munich, both in electrical engineering. From 1984 to 1990 he was a research and teaching assistant with the Lehrstuhl für Technische Elektrophysik at the Technical University of Munich. Then, as an employee of a telecommunication company he was engaged in R&D of low-cost optical glass fiber modules. Between 1992 and 1995 he led as project manager the EU-funded RACE II project POPCORN with the objective to develop a novel technology for the fabrication of integrated optical components by low-cost molding techniques. In July, 1998 he sourced out the results of this technology to a new founded company, HARTING Elektrooptische Bauteile GmbH&Co. KG. In September 2001 he founded the DieMount GmbH.

OLAF ZIEMANN (Olaf.Ziemann@pofac.ohm-hochschule.de) studied physics at the University Leipzig. He worked on his Ph.D. between 1990 and 1995 at the Technical University Ilmenau (Thuringia) in the field of optical communication. His working areas have been coherent optical detection and optical code multiplex. He worked at the technology center of Deutsche Telekom (T-Nova) between 1995 and March 2001 on the areas of hybrid access networks and building networks. Over the last 12 years, he was chairman of the Information Technology Society (ITG) Polymer Optical Fibers subcommittee. He also became the speaker of the ITG committee communication cable networks and the communication networks department. Since 2001 he has been a Professor and the scientific director of the Polymer Optical Fiber Application Center at the University of Applied Sciences Nürnberg and a member of the International Committee of Polymer Optical Fibers. He published the *POF-Handbuch/POF Handbook* in 2007/2008.

NORBERT WEBER [M'00] (norbert.weber@iis.fraunhofer.de) received Dipl.-Ing. and Dr.-Ing. degrees in electrical engineering from the University of Erlangen-Nuernberg in 1986 and 1989, respectively. In 1990 he joined the Fraunhofer-Institute for Integrated Circuits in Erlangen where he was involved in the development of a microwave spectrometer for gas analysis. In 1993 he became responsible for the microsystems and sensors group, and since 1999 for the optical communications group of the same institute. He has authored or co-authored more than 65 journal and conference papers, and holds five patents. Currently his research interests include high-speed circuit design and optical communications. He is a member of the IEEE Microwave Theory and Techniques Society (IEEE MTT-S), Laser and Electro-Optics Society (LEOS), and Solid-State Circuits Society (SSC). He received the 1986 Diploma Award from the technical faculty of the University of Erlangen-Nuernberg and the Georg-Waerber-Innovation Award in 2004.

TON (A.M.J.) KOONEN [M'00, SM'01, F'07] (A.M.J.Koonen@tue.nl) worked for more than 20 years, starting in 1979, in applied research in broadband telecommunication systems, first as a member of technical staff at Philips Telecommunication Industry, and since 1987 as technical manager with Bell Laboratories in AT&T Network Systems and Lucent Technologies. He also was a part-time professor at Twente University, Enschede, The Netherlands, from 1991 to 2000. Since 2001 he is a full professor at Eindhoven University of Technology in the Electro-Optical Communication Systems

Due to the efficient adaptation to the frequency dependent transfer function of the POF link Multi Carrier Modulation or, in particular, the OFDM technique currently provides the best solution for both, the medium and short range data transmission.

Group at the COBRA Institute, where he has chaired this group since 2004. His current research interests include broadband communication technologies and networks, in particular fiber access and in-building networks, radio-over-fiber networks, and optical packet-switched networks. He has initiated and led several European and national R&D projects on dynamically reconfigurable hybrid fiber access networks, fiber-wireless, packet-switched access, short-range multimode (polymer) optical fiber networks, and label-controlled optical packet routed networks. Currently, he is involved in a number of access/in-home research projects in Dutch Freeband and IOP Generieke Communicatie programs, and in the European FP7 ICT program (among others, ALPHA, POF-PLUS, and BONE). He authored and co-authored more than 300 conference and journal publications. He is a Bell Laboratories Fellow since 1998 and an elected member of the IEEE LEOS Board of Governors since 2007.

CARLO LEZZI (carlo.lezzi@fastweb.it) received his Dr-Ingenieur degree in mechanical engineering from the Politecnico di Milano in 1989. From 1989 to 1993 he worked for the Techint group as new technology research manager. From 1994 to 1999 he was a department manager at Swisslog group in the field of infrared communication systems for industrial material handling automation systems. Since 2000 he is with Fastweb as department manager for FTTH installations and engineering.

ANDREAS BLUSCHKE [M'07] (blua@teleconnect.de) has been a co-founder and currently is managing director of Teleconnect GmbH in Dresden, Germany, since 1990. He is particularly responsible for R&D activities and is an experienced project leader in the areas of PDH, SDH, ISDN, and ATM with his main focus being xDSL. He received his Dipl.-Ing. and Dr.-Ing. degrees in 1982 and 1986, respectively, from the Leningrad Electrical Institute of Communication (L.E.I.C.), USSR. From 1986 to 1988 he worked as an assistant at Hochschule für Verkehrswesen Dresden and was a

development engineer at ZFTN Dresden from 1988 to 1990. He is the author and editor of numerous books and journal articles on the topic of xDSL and access networks.

SEBASTIAN RANDEL [S'02, M'06] (sebastian.randel@siemens.com) received his Dipl.-Ing. as well as his Dr.-Ing. degree from Technical University Berlin in 2001 and 2005, respectively. His dissertation work dealt with physical layer issues of WDM transmission systems operating at 160 Gb/s per wavelength channel. In 2005 he joined Siemens AG, Corporate Technology in Munich as a research scientist where he is currently involved in activities on polymer optical fibers and optical wireless communications for industrial, automotive, and medical applications. His research interests also include efficient access network architectures as well as advanced modulation schemes for metro and long-haul networks. He is a member of the VDE.

DIETER JÄGER [F'01] (dieter.jaeger@uni-due.de) received Diplomphysiker, Dr. rer. nat., and Habilitation degrees in physics, all from Westfälische Wilhelms-Universität Münster, Germany, in 1969, 1974, and 1980, respectively. From 1974 to 1990 he was head of a research group at the Institute for Applied Physics, where he became an associate professor of physics in 1985. Since 1990 he has been with the Faculty of Electrical Engineering of the University of Duisburg, where he is head of the Department of Optoelectronics. His research interests include ultrafast optoelectronics for microwave power generation and transmission, millimeter-wave optical links for broadband communication technologies, and picosecond electrooptical measuring techniques. He also has activities in the areas of optical neural technology and optoelectronics for medical applications. He is Chair of the German IEEE Lasers & Electro-Optics Society (LEOS) chapter as well as a member of the IEEE Microwave Photonics Steering Committee. He is an honorary professor of Brasov University, Romania, and a consultant professor of Huozhong University of Science and Technology, China.

Two Latest Resources for Wireless Engineering Professionals

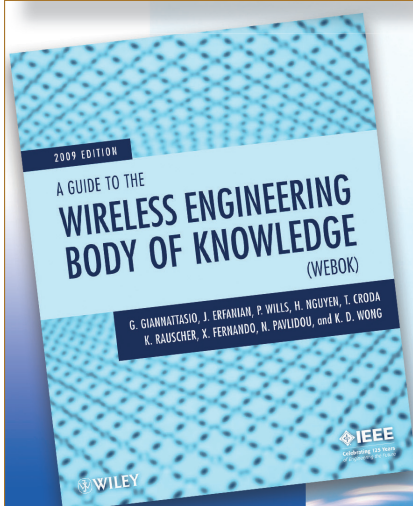

A Guide to the Wireless Engineering Body of Knowledge (WEBOK)

www.wiley.com

US \$69.95

IEEE Communications Society member order with 15% discount with Promo Code: 18493

+1 877 762 2974 (US)
+1 800 567 4797 (Canada)
+1 44 1243 843294 (world)

ISBN: 978-0-470-43366-9
Paper, 272pp, 2009



Recommended Resources for IEEE WCET Certification Program
www.ieee-wcet.org



ONLINE TUTORIAL -

WCET Area 3: Network and Service Architectures

by Daniel Wong

Focusing on Network and Service Architectures in wireless networks, this tutorial corresponds to Area 3 of the Wireless Communications Engineering Technologies (WCET) certification program.

www.comsoc.org/tutorialsnow