

source into multiple channels, all connecting to wavelength-matched FBGs and terminating into a receiving circuit.

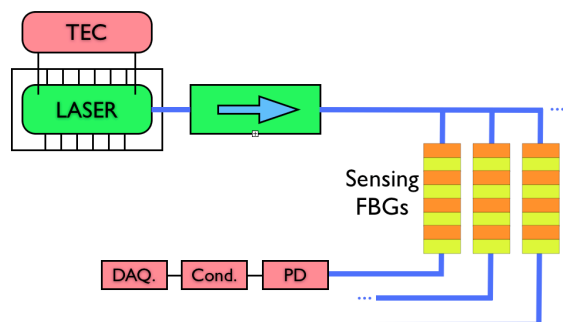

Fig. 3 Layout of the FBG interrogation system.

3 Signal processing

With the "pure" optical system, performances are limited by internal noise, due to the backreflection from FBGs into the laser cavity. Using adaptive filters, it is possible to reduce the internal noise without having prior knowledge of its spectral properties. By using a RLS filter trained in static conditions, we can improve the signal-to-noise ratio (SNR) by 14 dB.

We can have an additional gain by using an efficient spectral estimator. Using the Capon estimator as in [5], we obtained correct detection with SNR as low as -25 dB, corresponding to a net gain of 15 dB with respect to standard estimators such as FFT.

The result is that SP produces an outstanding increase of 29 dB in terms of SNR; with this value, the minimum oscillation amplitude that can be correctly processed in the frequency domain is 5.6 nε.

4 Experimental results

The proposed sensor has been used to measure vibrations in some simple structures as well as for the detection of acoustic waves, in order to validate performances for a broad spectrum of applications. Fig. 3 reports some results, obtained comparing the FBG sensor with a MEMS for the measurement of resonance frequency of a sample structure, and registering voice from a recorded speech.

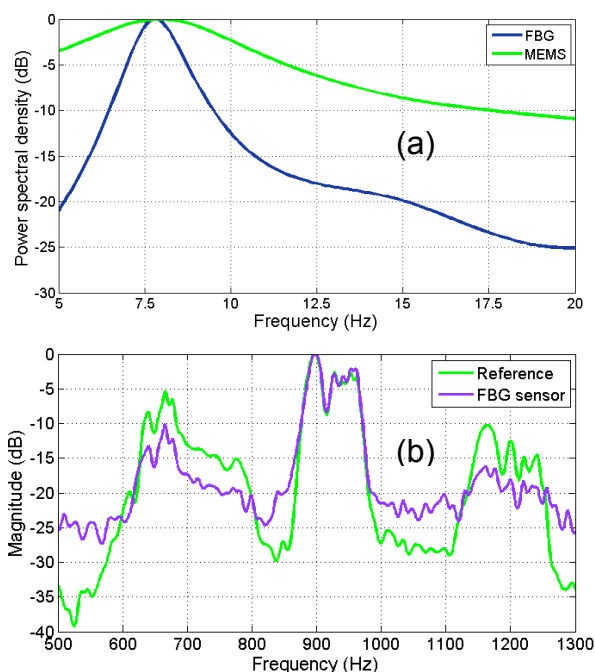

Fig. 4 Experimental results: (a) measurement of the resonance frequency of an aluminum bar, comparing the FBG sensor with a MEMS; (b) spectral measurement of recorded speech.

5 Conclusions

Performances of the sensing system, and the effect of SP, are resumed in Table 1.

| Performances | Optical | Optical + SP |
|---------------|---------|--------------|
| Minimum SNR | -10 dB | -39 dB |
| Accuracy | 800 nε | 5.6 nε |
| Working range | 60 με | 60 με |
| Resolution | << 1 nε | << 1 nε |

Tab. 1 Performances of the optical system, with and without the application of signal processing.

References

- [1] Y. J. Rao: „In-fibre Bragg grating sensors“ in *Meas. Sci. Technol.*, **8**: 355-75 (1997).
- [2] D. Tosi, M. Olivero, G. Perrone, „Low-cost fiber Bragg grating vibroacoustic sensor for voice and heartbeat detection“ in *Appl. Opt.*, **47**: 5123-29 (2008).
- [3] D. Tosi, M. Olivero, G. Perrone, „Dynamic strain measurement system with fiber Bragg gratings and noise mitigation techniques“ in *Meas. Sci. Technol.*, **20**: (2009).
- [4] S. Haykin: *Adaptive Filters Theory* – 4th edition, Prentice Hall, 2001).
- [5] T. Ekman, A. Jakobsson, P. Stoica, „On efficient implementation of the Capon algorithm“ in *Proc. European Sign. Proc. Conference* (2000).