



Politecnico di Torino

Porto Institutional Repository

[Proceeding] Design Characteristics of a Non Conventional Thrust Vectedored Airship

Original Citation:

Battipede M.; P. Gili; L. Massotti; P. Vercesi (2003). *Design Characteristics of a Non Conventional Thrust Vectedored Airship*. In: UAV International Technical Conference and Exhibition, Paris, France, June 10-13, 2003.

Availability:

This version is available at : <http://porto.polito.it/1605599/> since: December 2016

Terms of use:

This article is made available under terms and conditions applicable to Open Access Policy Article ("Public - All rights reserved") , as described at http://porto.polito.it/terms_and_conditions.html

Porto, the institutional repository of the Politecnico di Torino, is provided by the University Library and the IT-Services. The aim is to enable open access to all the world. Please [share with us](#) how this access benefits you. Your story matters.

(Article begins on next page)

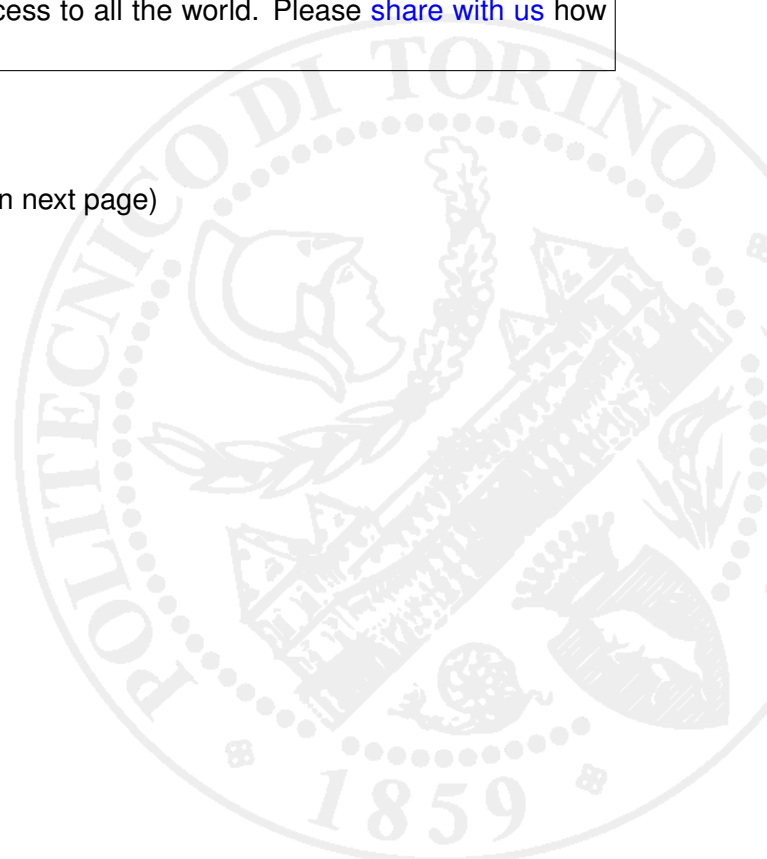

UAV 2003 International Technical Conference & Exhibition
Paris, France – June 10-13, 2003

Design Characteristics of a Non Coventional Thrust- Vectored Airship

M. Battipede* Ph.D. Researcher
P.A. Gili† Associate Professor
L. Massotti† Ph.D. Student
P. Vercesi‡ CEO Nautilus

*Mechanical Department, Politecnico di Torino – Torino, ITALY

†Aeronautical and Space Department, Politecnico di Torino – Torino, ITALY



‡Nautilus S.r.l. – Alessandria, ITALY





Introduction

In the last few years the interest on unmanned aerial vehicles has grown for both commercial and military applications. In the present market, remotely-piloted airships represent the most interesting vehicle for low speed, low altitude exploration and monitoring missions. They have already proved themselves as camera and TV platforms as well as specialised scientific tasks. As a matter of fact its aerostatic lift makes it noiseless, non-obtrusive, ecological and useful for environmental applications^[1], such as oceanographic^{[2]-[3]} and agricultural studies, traffic monitoring, ecological and climate research, inspection of endangered ecological sites as well as long-term variability studies. Actually, airship can operate as a rotary-wing aircraft but it benefits from the absence of rotors, which generally imply high structural design costs and strong payload (cameras and monitoring equipments) vibrations.

The most crucial aspect of the conventional airship handling is its scarce capability of operating in adverse environmental conditions. This is due to the features of the primary command system, which is generally adopted for a conventional airship, together with the low weight and the big size of the whole body. Aerodynamic surfaces, in fact, are poorly efficient as they are generally covered by the separate stream of the hulls^[4]. Moreover, in low to moderate speeds, the aerodynamic surface deflections must be very large getting very close to the stall conditions even for standard maneuvers and light gusts.

The innovative lighter-than-air platform, by Nautilus s.r.l. (patent pending either for the aircraft configuration, for the maneuver and control system and for the altitude variation management system), features an architecture and a command system designed to overcome these problems, to improve maneuverability and enlarge the conventional airship flight envelope, with a special concern in the VTOL and hovering capabilities, both in normal and severe wind conditions.

This paper is focused on the presentation of the general design characteristics. The unmanned airship (Figure 1) features a double hull architecture with a central plane housing structure and propellers. Lift is provided by a

hybrid system consisting in helium for the aerostatic lift and a system of vertical axis propellers which provide the vertical thrust for climb and descent maneuvers. In forward flight buoyancy is also enforced by the aerodynamic lift of the whole body.

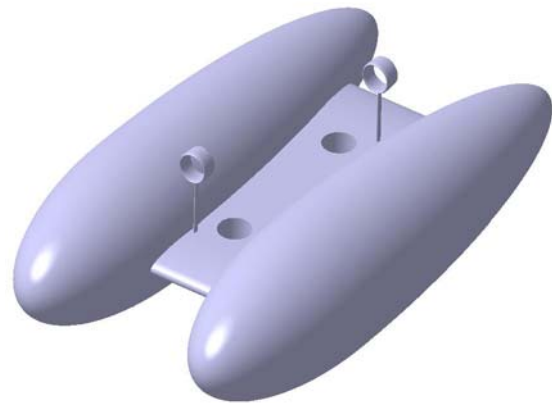

Figure 1: The Nautilus new concept unmanned airship

As shown in Figure 1, the Nautilus unmanned airship does not use aerodynamic control surfaces. The primary command system consists in six propellers properly set to obtain a system of forces and moments, suitable to control and manoeuvre the airship in pitch, roll and yaw. All the propellers are moved by electrical motors fed with an on-board generation system.

Two of them, has already been mentioned as the vertical axis propellers used to provide vertical thrust, but they also contribute, by differential fore and aft rotational speed, to pitch. The other four propellers are mounted on vertical arms, disposed at a proper distance from the whole body center of gravity: the arms rotation, together with the variation of the propellers rotational speed, should allow to vary the direction and the absolute value of each thrust propeller. In this way the airship can be maneuvered in pitch, roll and yaw.

Due to the intrinsic instability of the fuse architecture, a Stability Augmentation System (SAS) has been designed to achieve the desired dynamic characteristics. In addition, the airship will be equipped with a set of Control Augmentation Systems (CAS) with autopilot capabilities, to keep the steady-state flight conditions and follow specific flight-paths^[5].



Politecnico di Torino

In order to handle altitude variations without losing helium from the hulls, the airship is equipped with ballonets which are managed through an *ad-hoc* pneumatic system consisting in pipes and valves. The functional scheme of this pneumatic mechanism will be presented in the next sections.

An innovative cockpit design is also being developed to cope with the unconventional command system. As this matter seems to be crucial, modelling is fundamental to implement several cockpit options. This should allow to select the best solution to satisfy the standard aviation regulations, which require that a standard skilled pilot might learn to fly the vehicle without too demanding training sections.

Design requirements

The design requirements are summarised in Table 1 which explains the basic characteristics of both prototype and mass-produced airship.

	Prototype	Serie
Flight autonomy (75% of the maximum power)	2h	6H
Max velocity	15 m/s	20 m/s
Abeam wind maximum force	5 m/s	8 m/s
ISA max altitude	2000 m	6000 m
Payload	30 kg	80 kg
Max rate of climb	3 m/s	4 m/s
Length	20 m	20 m
Diameter (length/diameter=4)	5 m	5 m
Power of a single translational engine	5 kW	7 kW
Power of a single vertical thrust engine	7 kW	10 kW
Empty weight (without the energy source)	300 kg	300 kg

Table 1: Basic characteristics

In order to build the prototype within a year, it was established to make use of a hybrid fuel cells/batteries system similar to the mass-produced airship one, even if the characteristics are not optimised yet. As a matter of fact, a long time will be required to adapt a fuel cell system to the airship power necessary. Strictly speaking, the prototype will be equipped with an energy generator heavier and less powerful than that assembled on the mass-produced airship. For this reason performance and flight envelope are remarkably different comparing the prototype and definitive airship.

The characteristics of the hull and ballonets covering (discussed into details in the



Nautilus S.r.l

section relative to the altitude variation handling) enable to minimize the gas leakage. The material weighs about 280 g/m² for the hulls (rip-stop fabric) and about 100 g/m² for the ballonets (polyurethane film).

An important and peculiar characteristic of this machine is the ability to maintain the hovering with each aft, independently of the wind direction: in Table 1 is shown the abeam wind maximum force, which is the worst case scenario. Obviously, when the hovering is maintained on the wind, the wind force could be equal to the translational maximum speed.

Also the airship certification could not be done in a brief time according to the JAR/ENAC standards. The prototype will perform experimental and demonstrative flights approved through certificates of authorization issued by qualified authorities.

FTI and link

It was compiled a list of parameters (shown in Table 2) which are necessary to the flight tests for the experimental verification of the machine from various angles: performance, dynamic response and control, structure and aerodynamics. In addition, Table 2 includes the sensors which must be installed on board to measure the relative parameters for the definition of the Flight Test Instrumentation (FTI) system. Almost all the listed parameters will be utilised also as feed-back signals by automatic control systems.

Parameter	Sensor
Barometric altitude	Altimeter
Velocity	Pitot and fan
External air temperature	Thermometer
Angle of attack α	Fin
Sideslip angle β	Fin
Nord-East-Down position	GPS
Propulsion engine angular position	Encoder
RPM of the propulsion and climb engines	Speedometer
Battery level	Charge meter
Angular positions	Inertial platform
Angular rates	Inertial platform
CG linear accelerations	Accelerometers/inertial platforms
Current – Engine voltage	Hall effect sensor – voltmeter
Engine thrust	Extensimeter
Hulls gas Δp	Barometric capsule



Politecnico di Torino

Nautilus S.r.l

Helium temperature in the hulls	Thermoprobe
Structural loads	Extensimeter
On/off cases (valves)	Switch

Table 2: Measured parameters and sensors

The main characteristics of each parameter have been defined in terms of range, accuracy, frequency and sample time.

A telemetry/on-board recording mixed solution was chosen for the data transmission system. The command transmission on the prototype, which will fly in VFR (Visual Flight Rules) conditions, consists in a simple radio-transmitter, whereas the operating airship will be equipped with a satellitar link.

Aerodynamic characteristics

The aerodynamic force and moment coefficients were estimated for the Nautilus airship at different Reynolds numbers, in particular at 2 m/s, 4 m/s, 8m/s and 20 m/s.

The simulation was performed through NSAERO, a finite volume multi-block computing code, which solves the Navier-Stokes equations. This code makes use of the fully conservative up-wind formulation. An implicit temporal solution was selected, whereas for the spatial discretization it was chosen a 3rd order up-wind biased scheme. The viscous effect simulation is obtained coupling the turbulent model to the Spalart-Allmaras equation: this is the best compromise between simulation efficiency and computing relief.

In order to obtain the complete matrix for dynamic simulations ($-90 \leq \alpha \leq +90$; $-180 \leq \beta \leq +180$), a reduced matrix was computed as an acceptable ingegneristic support to the subsequent interpolation according to required attitudes. This matrix was provided relative to the speed 4 m/s and further reduced matrices were computed for 2 m/s, 8 m/s and 20 m/s, deriving missing values through an interpolation based on the Re effect.

The no perfect simmetry of the machine (because of the arms sustaining the propellers) relative to the XZ and XY planes, imposes the aerodynamic coefficient determination for positive and negative α and β .

In Figure 2 and Figure 3 an example of the C_x aerodynamic coefficient trend is provided for 4 m/s and α up to 90° .

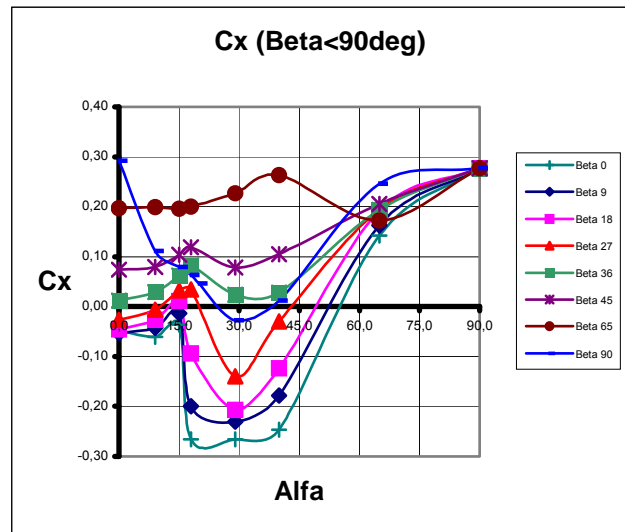

Figure 2: C_x coefficient as a function of α for $0 \leq \beta \leq 90$.

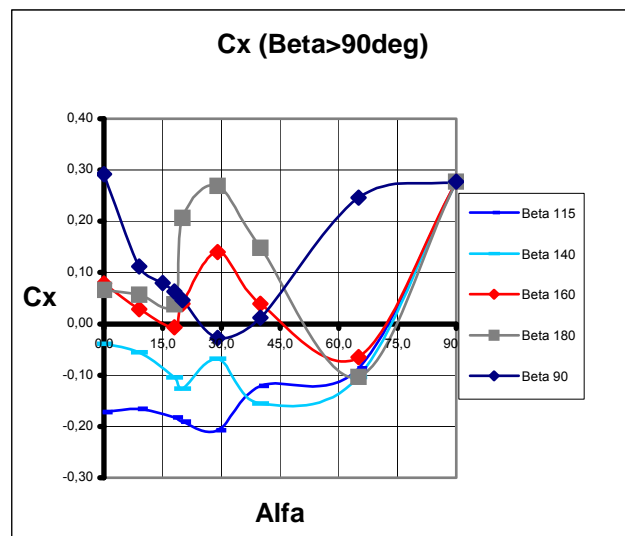

Figure 3: C_x coefficient as a function of α for $90 \leq \beta \leq 180$.

Maneuver and control procedure

At the time being, the control and maneuvering capability of the airship is tested using a 6 DOF nonlinear mathematical model set-up *ad hoc* on the base also of some well known model^[6,7]. It is implemented in a graphical software environment within Matlab/Simulink, which simplifies the validation of control and navigation strategies. To display and evaluate the pilot interaction, the dynamic model is



Politecnico di Torino

interfaced with the *Virtual Reality Toolbox* simulation package and is flown through a joystick and two thruttles. This hardware version of the control system has been accomplished and linked (*hardware-in-the-loop*) to the *Simulink* environment for real time simulations.

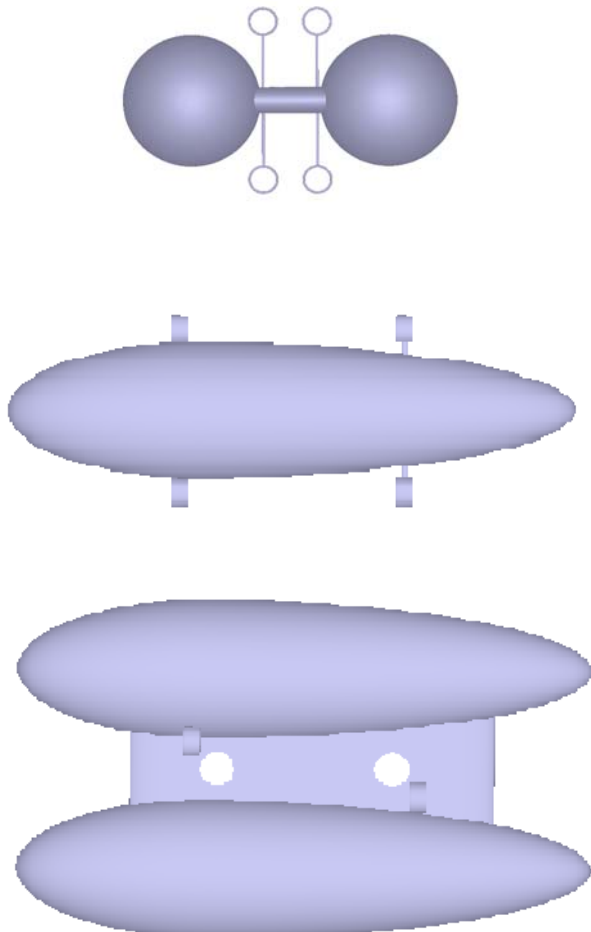

Figure 4: Airship triptych

Referring to Figure 4, the control procedure will be briefly explained. Control strategies are different according to both flight possible situations, hovering and forward flight. A simple switch enables to change strategy according to what is more convenient in the current flight condition. In both cases, a throttle equally varies the RPM of the 4 forward propellers at the same time, while another throttle controls the RPM of the vertical axis propellers.

The joystick has three degree of freedom and the control strategy changes according to the hovering or forward flight. In this case the rotation around the joystick



Nautilus S.r.l

vertical axis generates a yaw moment through the differential rotation of the thrust axes of front and rear engines; the lateral shift of the stick causes a differential rotation of the thrust axes of the upper and lower engines, generating a roll moment; finally, the longitudinal command of the stick causes a differential variation of the RPM of horizontal and vertical axis propellers, generating a differential thrust and consequently a pitch moment.

On the other hand, in the hovering control strategy, the rotation around the joystick vertical axis generates the concordant rotation of thrust axes of all the forward propellers, according to the desired direction (namely the wind direction that must be opposed). The longitudinal command of the stick causes a differential thrust as in the forward flight condition, while the stick lateral shift generates a rotation around the body Z axis through convenient differential thrusts of the propellers, in order to orient the airship in the desired aft.

Altitude variation

As mentioned above, also the pneumatic system, which manages the ballonets, is patent pending.

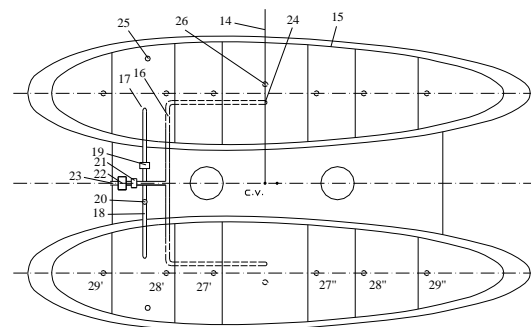

Figure 5: Ballonet system

Referring to Figure 5, the airship should be equipped with two ballonets (15), one for each hull, to allow the altitude variation in a predetermined range without gas leakage. Ballonets are communicating as the gas volumes of the hulls; in particular, ballonets communicate through a duct (16), which exactly ends in the transversal plane (14) where the centre of volume C.V. lies. Hulls communicate through a duct (18), whose outlet (17) is in the hulls; in this duct there are an automatic valve (19), (closed when the bank angle is not null), and a helium immission small opening (20). At



Politecnico di Torino

the beginning of the duct (16), whose entrance consists of a dynamic intake (23) which acts also as the ballonnet inflate small opening, there are an unidirectional valve (21) to prevent the air leakage from ballonets, and a compressor (22) to keep ballonets pressure. At the end of the duct there is the ballonnet immission outlet (24), exactly set in the C.V. hull section and in the middle of ballonets. The differential pressure corresponding to the opening of hulls security valves (25), turns out to be greater than that of ballonnet valves (26), (27), (28) and (29). In addition they are only opened when the airship reaches the plenitude altitude, namely the altitude to which the gas is completely expanded filling hulls. Strictly speaking, this height will be also the operative maximum altitude without losing helium (do not forget that this leakage causes also a loss of buoyancy). Both hull valves (25) can be driven for security reasons, i.e. in a failure case when the airship must quickly descend. Consequently during the climb, at first the air is released from ballonets and then, if the altitude increases further on, the helium is also released from hulls. During the discent, ballonets are blown up using the dynamic intake (23) and compressor (22).

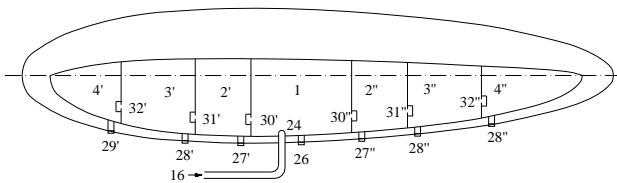

Figure 6: Ballonnet system management

During the climbing phase (refer to Figure 6), ballonets deflate progressively from outside to inside (from 4 to 1) through valves from (29) to (26). Obviously the internal overpressure toward the outside slightly grows, but it is kept in a rather limited range. During the discent phase, ballonets inflate progressively from partition 1 to 4 through the outlet (24) after the duct (16), and then through valves (30), (31) and (32) opening in succession with a pressure delta between partitions. In this way the air and gas centre of volume are kept approximately in a fixed and coincident hull section, and the thrust



Nautilus S.r.l

centre higher than the centre of gravity (useful condition for the lateral stability).

The starting procedure will follows the next steps:

1. Fixed the payload and the desired maximum autonomy, the fuel weight and also the take-off total weight are established univocally.
2. The helium amount to introduce into hulls is established fixing the static heaviness (consequent to security reflections). When the structure leans on the ground and balloons (hulls and ballonets) are completely deflated, the immission of the necessary helium volume can be accomplished through the small opening (20).
3. The ballonnet inflating can be performed through the compressor (22) till the value of the overpressure fixed by the flight speed (it is obvious that the hull internal overpressure must overcome the dynamic pressure in the points where the air flow stops). A powerful external compressor could be used when the airship is on the ground in order to diminish inflating times before the take-off.
4. Ignite the engines and take-off.

The airship support system on the ground will be discussed in the section relative to the structure.

The structure

Brief description of the central structure

The aim of the central structure is to sustain the payload, to provide a mounting point for both horizontal and vertical engines of the airship and a structural link for the envelopes. During the preliminary design, two types of central structures have been considered, the first is a box in composite materials and the second a bay-truss structure. In the following, only the prevailing characteristics of the structural design of the box in composite materials are addressed.

The box is obtained by joining sandwich panels in composite materials. Figure 7 shows that the structure has two cells, mainly due to the relatively large dimension of 2.2 m, and it is built by using three longerons and several ribs. To reduce the usage of joints, it is advisable to build longerons (with dimensions 3.6 m x 1 m) and upper and lower panels (with dimension 3.6 m x 2.27 m) as a single piece, if permitted by



Politecnico di Torino

the autoclave in use. Furthermore, the lower panel has several openings permitting to access to the interior volume of the structure for payload accommodation.

The payload installed into the structure (i.e., the energy generation subsystem mainly) will be connected to the vertical walls of the box (longerons and ribs). In particular, Figure 7 shows the possible location of the payload, in terms of the center of gravity of each mass (the sum of the three masses is equal to 300 kg). To assure a conservative estimation of the stresses in the panels, it has been assumed that the payload is located in one cell only of the two available, giving rise to a twisting moment acting on the structure. It must be underlined that the entity of each mass must be evaluated in order to guarantee the equilibrium of the airship along the pitching direction.

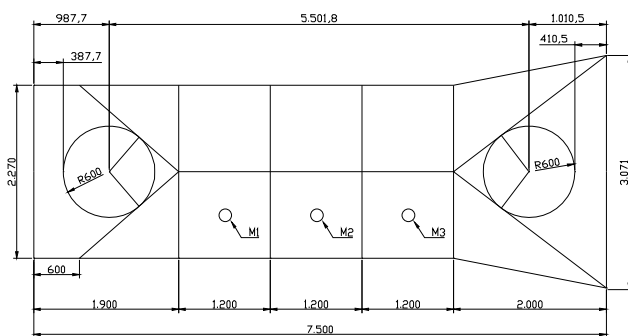

Figure 7: Central structure.

In the two sections at the ends of the central structure, where the vertical engines are installed, two panels are directed diagonally with respect to the airship axis, so that to provide a better structural load path from the ends to the middle of the structure. As a result, the two cylindrical flow tubes of the vertical engines do not participate at the capability of the structure to sustain loads and the engines are connected through two beams (shown in Figure 7) to the diagonal panels. This connection will be realized by using fasteners.

In order to reduce the structural mass, sandwich panels with graphite-epoxy composite faces (plain weave fabric) with a thickness of 0.2 mm and core (Rohacell) with a thickness of 8 mm will be employed. A schematic view of the connection between adjacent panels is shown in sections A and B of Figure 8, while Figure 10 shows the arrangement of the edges of the panels in order to permit joining. This type of connection has the advantage that at least one



Nautilus S.r.l

part of the joint is loaded in shear under the action of a load in the plane of the box section.

Some parts of the box (e.g., the two ends) can be built in a more simple way by using two sandwich panels only and a T joint than by using the previous connection (section B, Figure 8). In this case, the use of a simple bonded connection between the upper (lower) panel and the horizontal edge of the vertical panel is improper, since the adhesive could be loaded in traction, so that a mechanical joint using fasteners can be preferred. Finally, this kind of connection can be employed also to join the upper (lower) panel with the central longeron of the middle section of the box.

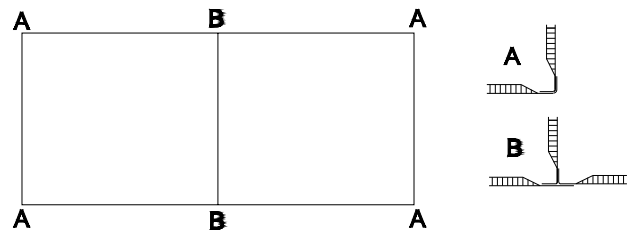

Figure 8: Connection between panels of a section.

The airship is characterized by the presence of a couple of retractile landing devices formed by rods properly connected to a worm gear permitting the device, which is almost adherent to the envelopes during the flight, to be fully extended for landing. Figure 10 show half of the airship with a schematic view of both positions of the device.

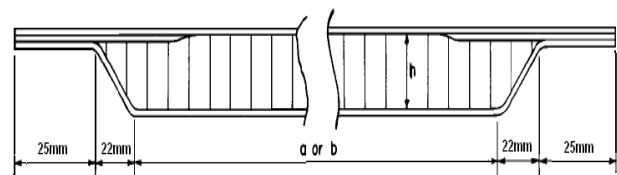

Figure 9: Cross-section of the sandwich panel with edges shaped for connection with adjacent panels.

The main property of this landing device is that the helium into the envelopes behaves like a spring, permitting the kinetic energy of the airship to be transferred to internal energy of the helium into the envelopes.

Design loads

The radio-controlled airship is characterized by vectorized thrust so that lifting surfaces are



Politecnico di Torino

absent. As a result, loads acting on the structure are due to the combination of:

1. propellers giving rise to a horizontal force (its maximum value is of 200 N);
2. propellers giving rise to a vertical force (the propeller dish is evident in Figure 7) and its maximum value is of 400 N;
3. buoyancy, equal to the airship weight when the vertical engines are switched off. It is assumed that the connection between the envelopes and the central structure is realized by using localized mechanical joints, so that at the eight vertex of the box are acting forces along the vertical direction and equal to 662 N.
4. load due to a person walking on the central structure (force of 300 lbs on 7.6 cm^[8]).

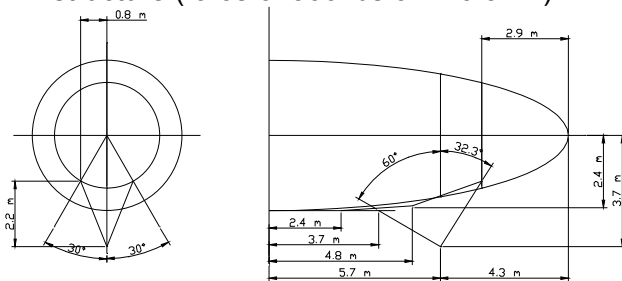

Figure 10: Schematic view of the landing device.

In order to determine limit loads, the wrong orientation of the engines giving rise to a constant bending moment or a constant twisting moment on the box are considered.

As a consequence, the following load cases are considered:

1. vertical engines at maximum thrust, horizontal engines generating the bending moment.
2. Vertical engines at maximum thrust, horizontal engines generating the twisting moment.
3. Both vertical and horizontal engines switched off, airship on the ground and loaded by buoyancy and by the walking load.

Design loads have been determined by analysing the previous three load cases and establishing maximum loads (limit loads) acting on the airship. For each load case the variation of stress resultant (shear, bending and twisting moment) has been plotted along the airship axis, permitting stresses in the panels to be evaluated. Subsequently, strength, stiffness and buckling verification have been performed, demonstrating that the sandwich panels



Nautilus S.r.l

described in the previous section are capable of sustaining the loads and of providing the necessary stiffness.

Energetic font

In order to generate energy on board, a hybrid system batteries/hydrogen fuel cells was chosen to tackle the required energy peaks and emergency situations. The prototype energetic plant will consist in a fuel cell system of about 30 kW and batteries able to support a halved power request for about 12 minutes.

The assumptions for the system sizing are the following:

- Mean efficiency: $\eta = 0.5$.
- Inferior heating power of the hydrogen: $P_{cal} = 3 \text{ kWh/Nm}^3$.
- Hydrogen density in standard conditions: $\rho = 0.09 \text{ kg/Nm}^3$.
- Power density of a fuel cell: $d = 885 \text{ W/kg}$.
- Mean specific weight of a tank in composite material to stock hydrogen at high pressure (reference to stock products till 250 bar): $s = 0.35 \text{ kg/litre}$.

10% T	100% Pmax
40% T	40% Pmax
40% T	10% Pmax
10% T	20% Pmax

Table 3: Mission profile.

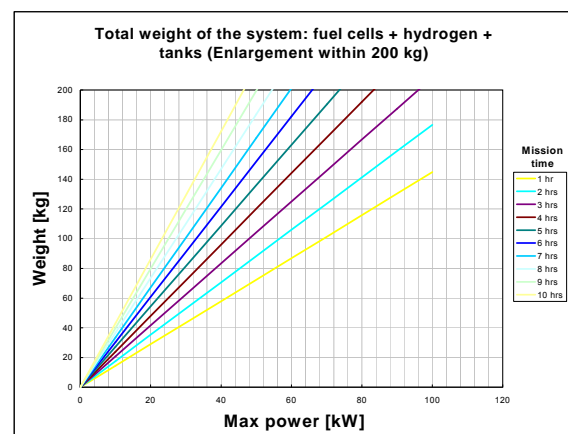

Figure 11: Total weight of the energetic system.

Moreover, the study is referred to a standard mission, whose percentile necessary of the maximum power P_{MAX} is divided for the mission time T as shown in Table 3. According to these preliminary issues, the total weight valuation of



Politecnico di Torino

the installed energetic system provides the results pointed out in Figure 11.

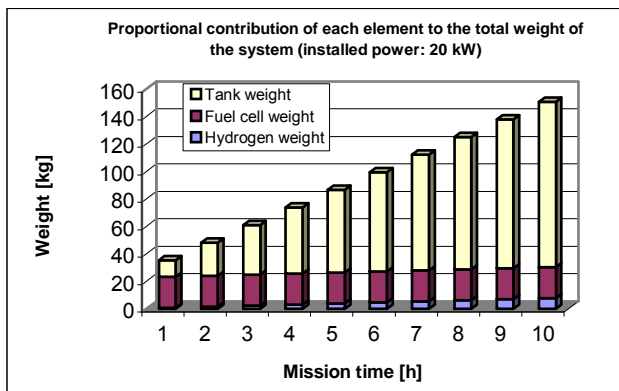

Figure 12: Weight contributions to the energetic system.

The oxygen is not included in the valuation because it will be supplied by the atmosphere. It can be noticed that a partial recovery of the water produced by cells can be carried out in order to maintain the starting static heaviness. Moreover, Figure 12 shows how the hydrogen amount spent during the mission is limited even if the mission time varies remarkably.

Conclusions

In the present circumstances the design is focused on the subsystem test and assembling. In particular three subsystems are going to be set-up: the pneumatic system to manage ballonets, the hull and ballonet coverings and the propeller rotation system (the whole system is lodged in the upper part of the arms which sustain fans). Moreover horizontal and vertical axis propellers are going to be optimised after the building of an *ad-hoc* test stand.

The schedule foresees the conclusion of the subsystem tests, the acquisition of all the sensors, instruments and components to assemble on board, the structural optimisation (in order to reduce weights) and the detailed design within 2003. In 2004 the prototype will be built and first flight tests are scheduled in spring/summer 2004.

Flight tests performed on the airship flight simulator, seem to be promising: the airship is sufficiently maneuverable even if in a open-loop configuration, namely without automatic control systems.



Nautilus S.r.l

References

- [1] Elfes A., Bueno S.S., Bergerman M., Ramos J.Jr.G., "A Semi-Autonomous Robotic Airship for Environmental Monitoring Missions", *Proceedings of the 1998 IEEE International Conference on Robotics & Automation*, Leuven, Belgium, May 1998, pp. 3449-3455.
- [2] Zaugg D.A., Arnold D.V., Jensen M.A., "Ocean Surface and Landside Probing with a Scanning Radar Altimeter", *Proceedings of the 2000 International Geoscience and Remote Sensing Symposium*, vol. 1, 2000, pp. 120-120.
- [3] Hain J.H.W., "Lighter-than-air Platforms (Blimps and Aerostats) for Oceanographic and Atmospheric Research and Monitoring", *Proceedings of the Oceans 2000 MTS IEEE Conference and Exhibition*, vol. 3, 2000, pp. 1933-1936.
- [4] Khoury G.A., Gillett J.D., "Airship Technology", *Cambridge University Press*, 1999.
- [5] Carneiro de Paiva E., Bueno S.S., Gomes S.B.V., Ramos J.Jr.G., Bergermann M., "A Control System Development Environment for AURORA's Semi-Autonomous Robotic Airship", *Proceedings of the 1999 IEEE International Conference on Robotics & Automation*, Detroit, MI, May 1999, pp. 2328-2335.
- [6] Azinheira J.R., Carneiro de Paiva E., Ramos J.Jr.G., Bueno S.S., Bergerman M., Gomes S.B.V., "Extended Dynamic Model For Aurora Robotic Airship", *Proceeding of the 14th AIAA Lighter-Than-Air Technical Committee Convention & Exhibition*, Akron, OH, July 2001.
- [7] Varella Gomes S.B., Ramos J.Jr.G., "Airship Dynamic Modelling for Autonomous Operation", *Proceedings of the 1998 IEEE International Conference on Robotics & Automation*, Leuven, Belgium, May 1998, pp.3462-3467.
- [8] M.C.Y. Niu, "Composite Airframe Structures", *Conmlit Press Ltd.*, 1992, pag. 435.