

Generalized Mixed-Mode S -Parameters

Andrea Ferrero, *Member, IEEE*, and Marco Pirola, *Member, IEEE*

Abstract—This paper presents an innovative approach to extend the S -parameter definition to multiport networks having conventional single-ended and differential ports, as is the case for operational amplifiers, transformers and baluns. To give maximum generality to this technique, for example, allowing for complex S -parameter reference impedances, the mathematical derivation will be carried out with the most general definition of the S -parameters. The presented approach gives the same results already published for circuits with differential ports only when the required simplifications are applied.

Index Terms—Differential S -parameters, microwave measurements, mixed-mode S -parameters, multiport S -parameters.

I. INTRODUCTION

THE NEED of accurate experimental characterization of RF multiport differential circuits is dramatically increasing in today's communication market. Recent improvements in both device performances and system design techniques allow for the implementation of differential circuits and systems up to RF and microwave frequencies. In 1995, Bockelman and Einsenstadt [1] introduced so-called mixed-mode S -parameters to extend the classical single-ended power wave theory [2] to the differential case. Since then, the characterization through mixed-mode S -parameters has become rather common, either using traditional multiport vector network analyzers (VNAs) rather than dedicated mixed-mode ones [3], [4].

The theory shown in [1], however very innovative, can only be applied to circuits whose ports are all to be considered as common differential. Therefore, it cannot be extended to hybrid networks having some port naturally to be seen as single ended, and others more effectively to be considered as coupled. A simple, but relevant example, is the operational amplifier, where the single-ended output voltage is normally seen as a combination of the differential and common mode input voltages through the corresponding gains.

This paper generalizes the theory presented in [1] for a general n -port network sketched in Fig. 1, having an even number p of ports coupled in a common-differential way, while the remaining $(n - p)$ are left single ended. The relationship between the traditional single-ended n -port S -parameters, and the generalized mixed-mode ones presented here will be derived. It will also be shown that the formulation presented in [1] can be seen as a reduced case of the new one. The new formulation adopts the pseudowave definition introduced in [5], rather than the one

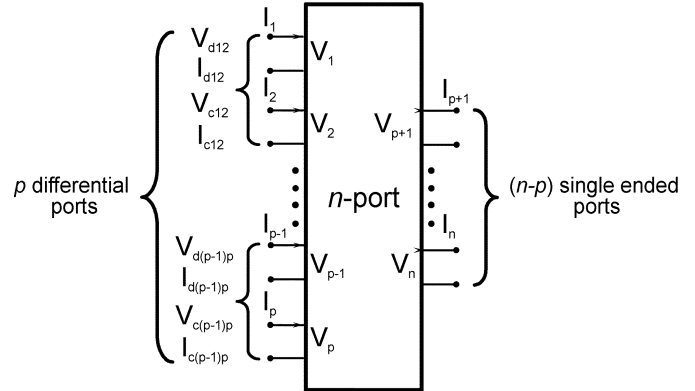

Fig. 1. n -port network with p -ports where differential parameters are defined and the remaining single ended.

used by Bockelman and Einsenstadt [1], therefore, enabling it to be used with complex reference port impedances. This issue is rather common at high frequency, and implicitly assumed each time a VNA thru-reflect line (TRL) calibration is adopted on dispersive media [6].

This paper is organized as follows. In Section II, the generalized mixed-mode n -port network is introduced, and the definition of coupled port S -parameters is assigned. In Section III, starting from the traditional single-ended n -port S matrix, the new generalized mixed-mode \hat{S} representation is defined, while in Section IV, an application example, proving the effectiveness of the new description, is given. Some conclusions are drawn in Section V.

II. n -PORT MIXED-MODE CIRCUIT

Let us consider the general n -port network shown in Fig. 1, and define the single-ended voltage and current state vector for the generic port j as

$$\mathbf{r}_j \equiv (V_j \quad I_j)^T \quad (1)$$

where the symbol T indicates the transpose operator.

The overall number of n -ports is split in two different sets: the mixed-mode port set (left-hand side of the network box in Fig. 1) composed by the even number of p -ports requiring the differential and common mode description, and the one given by the remaining single-ended $(n - p)$ ports (right-hand side of the network box in Fig. 1). On the generic port pair j, k of the

Manuscript received May 3, 2005.

The authors are with the Dipartimento di Elettronica, Politecnico di Torino, 10129 Turin, Italy (e-mail: andrea.ferrero@polito.it; marco.pirola@polito.it).
Digital Object Identifier 10.1109/TMTT.2005.860497

mixed-mode port set, we define the differential and common mode voltages and currents according to [1]

$$\begin{aligned} V_{djk} &\equiv V_j - V_k \\ I_{djk} &\equiv \frac{(I_j - I_k)}{2} \\ V_{cjk} &\equiv \frac{(V_j + V_k)}{2} \\ I_{cjk} &\equiv I_j + I_k \end{aligned} \quad (2)$$

and the corresponding mixed-mode voltage and current state vector

$$\overset{\circ}{\mathbf{r}}_{jk} \equiv (V_{djk} \ I_{djk} \ V_{cjk} \ I_{cjk})^T. \quad (3)$$

The expressions in (2) can be written in matrix notation as

$$\overset{\circ}{\mathbf{r}}_{jk} = \mathbf{T} \mathbf{r}_{jk} \quad (4)$$

$$\mathbf{T} = \begin{pmatrix} 1 & 0 & -1 & 0 \\ 0 & \frac{1}{2} & 0 & -\frac{1}{2} \\ \frac{1}{2} & 0 & \frac{1}{2} & 0 \\ 0 & 1 & 0 & 1 \end{pmatrix} \quad (5)$$

and the vector \mathbf{r}_{jk} is defined stacking up the single-ended state vectors of port j , k , \mathbf{r}_j , and \mathbf{r}_k , respectively,

$$\mathbf{r}_{jk} \equiv \begin{pmatrix} \mathbf{r}_j \\ \mathbf{r}_k \end{pmatrix}. \quad (6)$$

Choosing the n -port reference impedances possibly complex (however, with positive real parts), we can define the forward and reverse pseudowaves at port j according to [5]¹

$$a_j \equiv \alpha \sqrt{R_j} \frac{V_j + I_j Z_j}{2|Z_j|} \quad b_j \equiv \alpha \sqrt{R_j} \frac{V_j - I_j Z_j}{2|Z_j|} \quad (7)$$

where Z_j is the reference impedance at port j , R_j is its real part, and α is a free parameter whose only constrain is to have unitary modulus, from now on assumed to be 1. The port state vector in term of waves \mathbf{w}_j can be defined using (1) as follows:

$$\mathbf{w}_j \equiv \begin{pmatrix} a_j \\ b_j \end{pmatrix} = \mathbf{M}_j \mathbf{r}_j \quad (8)$$

where

$$\mathbf{M}_j = \frac{\sqrt{R_j}}{2|Z_j|} \begin{pmatrix} 1 & Z_j \\ 1 & -Z_j \end{pmatrix}. \quad (9)$$

Considering the port pair j and k of the mixed-mode port set, and introducing the reference impedances for the common and

¹This is not only the most general definition of waves, but also the only consistent definition with the measurement provided by network analyzers, as explained in detail in [5]. In the Appendix, the alternative *power wave* definition [2], [5] will be assumed, and the modifications occurring in this formulation will be shown.

mode differential Z_{djk} and Z_{cjk} , respectively, the mixed-mode pseudowaves are defined as

$$\begin{aligned} a_{djk} &\equiv \sqrt{R_{djk}} \frac{V_{djk} + I_{djk} Z_{djk}}{2|Z_{djk}|} \\ b_{djk} &\equiv \sqrt{R_{djk}} \frac{V_{djk} - I_{djk} Z_{djk}}{2|Z_{djk}|} \\ a_{cjk} &\equiv \sqrt{R_{cjk}} \frac{V_{cjk} + I_{cjk} Z_{cjk}}{2|Z_{cjk}|} \\ b_{cjk} &\equiv \sqrt{R_{cjk}} \frac{V_{cjk} - I_{cjk} Z_{cjk}}{2|Z_{cjk}|} \end{aligned} \quad (10)$$

where R_{djk} and R_{cjk} are the real parts of Z_{djk} and Z_{cjk} , respectively. From (10) and (4), the mixed-mode state vector is

$$\overset{\circ}{\mathbf{w}}_{jk} \equiv (a_{djk} \ b_{djk} \ a_{cjk} \ b_{cjk})^T = \overset{\circ}{\mathbf{M}}_{jk} \overset{\circ}{\mathbf{r}}_{jk} \quad (11)$$

where

$$\overset{\circ}{\mathbf{M}}_{jk} = \begin{pmatrix} \frac{\sqrt{R_{djk}}}{2|Z_{djk}|} & \frac{Z_{djk} \sqrt{R_{djk}}}{2|Z_{djk}|} & 0 & 0 \\ \frac{\sqrt{R_{djk}}}{2|Z_{djk}|} & -\frac{Z_{djk} \sqrt{R_{djk}}}{2|Z_{djk}|} & 0 & 0 \\ 0 & 0 & \frac{\sqrt{R_{cjk}}}{2|Z_{cjk}|} & \frac{Z_{cjk} \sqrt{R_{cjk}}}{2|Z_{cjk}|} \\ 0 & 0 & \frac{\sqrt{R_{cjk}}}{2|Z_{cjk}|} & -\frac{Z_{cjk} \sqrt{R_{cjk}}}{2|Z_{cjk}|} \end{pmatrix}. \quad (12)$$

Defining the overall wave state vector of the jk -port pair as

$$\mathbf{w}_{jk} \equiv \begin{pmatrix} \mathbf{w}_j \\ \mathbf{w}_k \end{pmatrix} \quad (13)$$

from (6) and (8), we have

$$\mathbf{w}_{jk} = \mathbf{M}_{jk} \mathbf{r}_{jk} = \begin{pmatrix} \mathbf{M}_j & \mathbf{0} \\ \mathbf{0} & \mathbf{M}_k \end{pmatrix} \mathbf{r}_{jk}. \quad (14)$$

Finally, from (4), (11), and (14) follows the relationship linking the classical single-ended, and mixed-mode pseudowave state vectors

$$\overset{\circ}{\mathbf{w}}_{jk} = \overset{\circ}{\mathbf{M}}_{jk} \mathbf{T} \mathbf{M}_{jk}^{-1} \mathbf{w}_{jk} = \mathbf{X}_{jk} \mathbf{w}_{jk} \quad (15)$$

where \mathbf{X}_{jk} is given in (16), shown at the bottom of the following page.

Equation (15) is the generalized form of [1, eq. (25)]. In fact, considering the port pair associated to the physical ports 1 and 2, adopting a unique real reference impedances R , and assuming $Z_{c12} = R/2$, and $Z_{d12} = 2R$, (16) simplifies to

$$\mathbf{X}_{12} = \frac{1}{\sqrt{2}} \begin{pmatrix} 1 & 0 & -1 & 0 \\ 0 & 1 & 0 & -1 \\ 1 & 0 & 1 & 0 \\ 0 & 1 & 0 & 1 \end{pmatrix} \quad (17)$$

which, once replaced within (15), gives

$$\begin{aligned} a_{d12} &= \frac{(a_1 - a_2)}{\sqrt{2}} \\ b_{d12} &= \frac{(b_1 - b_2)}{\sqrt{2}} \\ a_{c12} &= \frac{(a_1 + a_2)}{\sqrt{2}} \\ b_{c12} &= \frac{(b_1 + b_2)}{\sqrt{2}} \end{aligned} \quad (18)$$

which are the same expressions reported in [1]. It is worth noting that, in this simplified case, the mixed-mode waves a_{d12} and b_{d12} are only dependent on their single-ended counterparts; that is not true in the general case. For example, if a unique normalization resistance is adopted (e.g., $Z_j = Z_k = Z_{c12} = Z_{d12} = R$), we obtain

$$\mathbf{X}_{12} = \frac{1}{4} \begin{pmatrix} 3 & 1 & -3 & -1 \\ 1 & 3 & -1 & -3 \\ 3 & -1 & 3 & -1 \\ -1 & 3 & -1 & 3 \end{pmatrix} \quad (19)$$

and, therefore,

$$\begin{aligned} a_{d12} &= \frac{3a_1 + b_1 - 3a_2 - b_2}{4} \\ b_{d12} &= \frac{3b_1 + a_1 - a_2 - 3b_2}{4} \\ a_{c12} &= \frac{3a_1 - b_1 + 3a_2 - b_2}{4} \\ b_{c12} &= \frac{3b_1 - a_1 - a_2 + 3b_2}{4}. \end{aligned} \quad (20)$$

To obtain the overall generalized mixed-mode wave state vector $\overset{\circ}{\mathbf{w}}$, we combine the $\overset{\circ}{\mathbf{w}}_{jk}$ vectors, relative to the mixed-mode ports, together with the \mathbf{w}_j ones relative to the single-ended ports

$$\overset{\circ}{\mathbf{w}} \equiv \left(\overset{\circ}{\mathbf{w}}_{12} \overset{\circ}{\mathbf{w}}_{34} \cdot \overset{\circ}{\mathbf{w}}_{(p-1)p} \mathbf{w}_{p+1} \mathbf{w}_{p+2} \cdot \mathbf{w}_{n-1} \mathbf{w}_n \right)^T. \quad (21)$$

The original single-ended overall state vector is defined as

$$\mathbf{w} \equiv (\mathbf{w}_1 \mathbf{w}_2 \cdot \mathbf{w}_{n-1} \mathbf{w}_n)^T. \quad (22)$$

From (15), (21), and (22), the relationship between the two overall states becomes

$$\overset{\circ}{\mathbf{w}} = \overset{\circ}{\mathbf{E}} \mathbf{w} \quad (23)$$

$$\mathbf{X}_{jk} = \begin{pmatrix} \frac{|Z_j| \sqrt{R_{djk}} (2Z_j + Z_{djk})}{4\sqrt{R_j} |Z_{djk}| Z_j} & \frac{|Z_j| \sqrt{R_{djk}} (2Z_j - Z_{djk})}{4\sqrt{R_j} |Z_{djk}| Z_j} & -\frac{|Z_k| \sqrt{R_{djk}} (2Z_k + Z_{djk})}{4\sqrt{R_k} |Z_{djk}| Z_k} & -\frac{|Z_k| \sqrt{R_{djk}} (2Z_k - Z_{djk})}{4\sqrt{R_k} |Z_{djk}| Z_k} \\ \frac{|Z_j| \sqrt{R_{djk}} (2Z_j - Z_{djk})}{4\sqrt{R_j} |Z_{djk}| Z_j} & \frac{|Z_j| \sqrt{R_{djk}} (2Z_j + Z_{djk})}{4\sqrt{R_j} |Z_{djk}| Z_j} & -\frac{|Z_k| \sqrt{R_{djk}} (2Z_k - Z_{djk})}{4\sqrt{R_k} |Z_{djk}| Z_k} & -\frac{|Z_k| \sqrt{R_{djk}} (2Z_k + Z_{djk})}{4\sqrt{R_k} |Z_{djk}| Z_k} \\ \frac{|Z_j| \sqrt{R_{cjk}} (Z_j + 2Z_{cjk})}{4\sqrt{R_j} |Z_{cjk}| Z_j} & \frac{|Z_j| \sqrt{R_{cjk}} (Z_j - 2Z_{cjk})}{4\sqrt{R_j} |Z_{cjk}| Z_j} & \frac{|Z_k| \sqrt{R_{cjk}} (Z_k + 2Z_{cjk})}{4\sqrt{R_k} |Z_{cjk}| Z_k} & \frac{|Z_k| \sqrt{R_{cjk}} (Z_k - 2Z_{cjk})}{4\sqrt{R_k} |Z_{cjk}| Z_k} \\ \frac{|Z_j| \sqrt{R_{cjk}} (Z_j - 2Z_{cjk})}{4\sqrt{R_j} |Z_{cjk}| Z_j} & \frac{|Z_j| \sqrt{R_{cjk}} (Z_j + 2Z_{cjk})}{4\sqrt{R_j} |Z_{cjk}| Z_j} & \frac{|Z_k| \sqrt{R_{cjk}} (Z_k - 2Z_{cjk})}{4\sqrt{R_k} |Z_{cjk}| Z_k} & \frac{|Z_k| \sqrt{R_{cjk}} (Z_k + 2Z_{cjk})}{4\sqrt{R_k} |Z_{cjk}| Z_k} \end{pmatrix} \quad (16)$$

where Ξ is the $2n \times 2n$ matrix

$$\Xi = \begin{pmatrix} \mathbf{X}_{12} & \mathbf{0} & \cdot & \cdot & \cdot & \mathbf{0} \\ \mathbf{0} & \mathbf{X}_{34} & \cdot & \cdot & \cdot & \mathbf{0} \\ \cdot & \cdot & \cdot & \cdot & \cdot & \cdot \\ \cdot & \cdot & \cdot & \cdot & \cdot & \cdot \\ \cdot & \cdot & \cdot & \cdot & \mathbf{X}_{(p-1)p} & \cdot \\ \cdot & \cdot & \cdot & \cdot & \cdot & \mathbf{1} \end{pmatrix} \quad (24)$$

while $\mathbf{1}$ is the $2(n-p) \times 2(n-p)$ identity matrix relative to the single-ended ports. The description given by (23) is far more general than the traditional one based only on differential mode parameters; in fact, it can be extended to networks with differential and single-ended ports. Besides, as will be shown in Section III, it brings the relationship between the single-ended and generalized mixed-mode S -parameters to a general form.

III. GENERALIZED MIXED-MODE \mathbf{S} MATRIX

By introducing the $\overset{\circ}{\mathbf{a}}$ and $\overset{\circ}{\mathbf{b}}$ generalized mixed-mode wave vectors, which combine the p mixed-mode port set and the remaining $(n-p)$ single-ended ports

$$\overset{\circ}{\mathbf{a}} \equiv \begin{pmatrix} a_{d12} \\ a_{d34} \\ \cdot \\ \cdot \\ a_{d(p-1)p} \\ a_{c12} \\ a_{c34} \\ \cdot \\ \cdot \\ a_{c(p-1)p} \\ a_{p+1} \\ \cdot \\ \cdot \\ a_{n-1} \\ a_n \end{pmatrix} \quad \overset{\circ}{\mathbf{b}} \equiv \begin{pmatrix} b_{d12} \\ b_{d34} \\ \cdot \\ \cdot \\ b_{d(p-1)p} \\ b_{c12} \\ b_{c34} \\ \cdot \\ \cdot \\ b_{c(p-1)p} \\ b_{p+1} \\ \cdot \\ \cdot \\ b_{n-1} \\ b_n \end{pmatrix} \quad (25)$$

we can define the generalized mixed-mode scattering matrix $\overset{\circ}{\mathbf{S}}$ such as

$$\overset{\circ}{\mathbf{b}} \equiv \overset{\circ}{\mathbf{S}} \overset{\circ}{\mathbf{a}}. \quad (26)$$

The aim here is to find the relationship between the generalized mixed-mode scattering matrix $\overset{\circ}{\mathbf{S}}$ and the conventional single-ended one \mathbf{S} that links the forward \mathbf{a} and reverse \mathbf{b} vector waves. To achieve our goal, the vector $\overset{\circ}{\mathbf{w}}$ defined in (21) must be properly reordered with a set of matrices having all null elements apart a single “1” for each row as follows:

$$\begin{aligned} & \mathbf{P}_{da}, \mathbf{P}_{ca}, \mathbf{P}_{db}, \mathbf{P}_{cb} : \text{size } p \times 2n \\ & \mathbf{P}_{da}(l, 4l-3) = 1, \quad l = 1, \dots, p; \quad 0 \text{ elsewhere} \\ & \mathbf{P}_{ca}(l, 4l-1) = 1, \quad l = 1, \dots, p; \quad 0 \text{ elsewhere} \\ & \mathbf{P}_{db}(l, 4l-2) = 1, \quad l = 1, \dots, p; \quad 0 \text{ elsewhere} \\ & \mathbf{P}_{cb}(l, 4l) = 1, \quad l = 1, \dots, p; \quad 0 \text{ elsewhere.} \\ & \mathbf{P}_a, \mathbf{P}_b : \text{size } (n-2p) \times 2n \\ & \mathbf{P}_a(l, 4p+2l-1) = 1, \quad l = 1, \dots, p; \quad 0 \text{ elsewhere} \\ & \mathbf{P}_b(l, 4p+2l) = 1, \quad l = 1, \dots, p; \quad 0 \text{ elsewhere.} \end{aligned} \quad (27)$$

By collecting them into a $2n \times 2n$ permutation matrix \mathbf{P} , we find

$$\overset{\circ}{\mathbf{w}} \equiv \begin{pmatrix} \overset{\circ}{\mathbf{a}} \\ \overset{\circ}{\mathbf{b}} \end{pmatrix} = \begin{pmatrix} \mathbf{P}_{da} \\ \mathbf{P}_{ca} \\ \mathbf{P}_a \\ \mathbf{P}_{db} \\ \mathbf{P}_{cb} \\ \mathbf{P}_b \end{pmatrix} \overset{\circ}{\mathbf{w}} = \mathbf{P} \overset{\circ}{\mathbf{w}}. \quad (28)$$

In a similar way, we also introduce other two $n \times 2n$ matrices

$$\begin{aligned} \mathbf{Q}_a(l, 2l-1) &= 1, \quad l = 1, \dots, p; \quad 0 \text{ elsewhere} \\ \mathbf{Q}_b(l, 2l) &= 1, \quad l = 1, \dots, p; \quad 0 \text{ elsewhere} \end{aligned} \quad (29)$$

and combine them into another permutation matrix \mathbf{Q} to reorder the whole single-ended wave state and obtain the swapped state $\tilde{\mathbf{w}}$

$$\tilde{\mathbf{w}} \equiv \begin{pmatrix} \mathbf{a} \\ \mathbf{b} \end{pmatrix} = \begin{pmatrix} \mathbf{Q}_a \\ \mathbf{Q}_b \end{pmatrix} \mathbf{w} = \mathbf{Q} \mathbf{w}. \quad (30)$$

From (23), (28), and (30), we obtain the relationship between the reordered single-ended state and the corresponding generalized mixed-mode one ($\mathbf{Q}^T = \mathbf{Q}^{-1}$ [7])

$$\overset{\circ}{\mathbf{w}} = \mathbf{P} \Xi \mathbf{Q}^T \tilde{\mathbf{w}} = \tilde{\Xi} \tilde{\mathbf{w}}. \quad (31)$$

By splitting $\tilde{\Xi}$ into four squared $n \times n$ submatrices,

$$\tilde{\Xi} = \begin{pmatrix} \tilde{\Xi}_{11} & \tilde{\Xi}_{12} \\ \tilde{\Xi}_{21} & \tilde{\Xi}_{22} \end{pmatrix} \quad (32)$$

we find

$$\overset{\circ}{\mathbf{a}} = \tilde{\Xi}_{11} \mathbf{a} + \tilde{\Xi}_{12} \mathbf{b} \quad \overset{\circ}{\mathbf{b}} = \tilde{\Xi}_{21} \mathbf{a} + \tilde{\Xi}_{22} \mathbf{b}. \quad (33)$$

Finally, from (26) and (33), and by using $\mathbf{b} = \mathbf{S} \mathbf{a}$, the direct and inverse transformations linking $\overset{\circ}{\mathbf{S}}$ to \mathbf{S} become

$$\overset{\circ}{\mathbf{S}} = (\tilde{\Xi}_{21} + \tilde{\Xi}_{22} \mathbf{S})(\tilde{\Xi}_{11} + \tilde{\Xi}_{12} \mathbf{S})^{-1} \quad (34)$$

$$\mathbf{S} = (\tilde{\Xi}_{22} - \overset{\circ}{\mathbf{S}} \tilde{\Xi}_{12})^{-1} (\tilde{\Xi}_{21} - \overset{\circ}{\mathbf{S}} \tilde{\Xi}_{11}). \quad (35)$$

Equation (34) represents the generalized form of the single-ended to mixed-mode scattering matrix transformation given in [1, eq. (7)]. In fact, if the circuit has four common-differential ports only, and once again it is assumed $Z_{c12} = R/2$ and $Z_{d12} = 2R$, we obtain

$$\tilde{\Xi}_{11} = \tilde{\Xi}_{22} = \mathbf{M} = \frac{1}{\sqrt{2}} \begin{pmatrix} 1 & -1 & 0 & 0 \\ 0 & 0 & 1 & -1 \\ 1 & 1 & 0 & 0 \\ 0 & 0 & 1 & 1 \end{pmatrix} \quad \tilde{\Xi}_{12} = \tilde{\Xi}_{21} = \mathbf{0} \quad (36)$$

where $\mathbf{0}$ is the $n \times n$ null matrix and (34) becomes, as expected, $\overset{\circ}{\mathbf{S}} = \mathbf{M} \mathbf{S} \mathbf{M}^{-1}$.

In the special case of circuits with only n classical single-ended ports, the matrix $\tilde{\Xi}$ is the $n \times n$ identity matrix, $\tilde{\Xi}_{22} = \tilde{\Xi}_{11} = \mathbf{1}$, $\tilde{\Xi}_{12} = \tilde{\Xi}_{21} = \mathbf{0}$, and (34), as expected, gives $\overset{\circ}{\mathbf{S}} = \mathbf{S}$. However, (34) and (35) can be used with any number of ports, and with whatsoever, even complex, reference impedances.

The generalized $\overset{\circ}{\mathbf{S}}$ matrix can be split into nine submatrices highlighting the self- and cross-coupling between the differen-

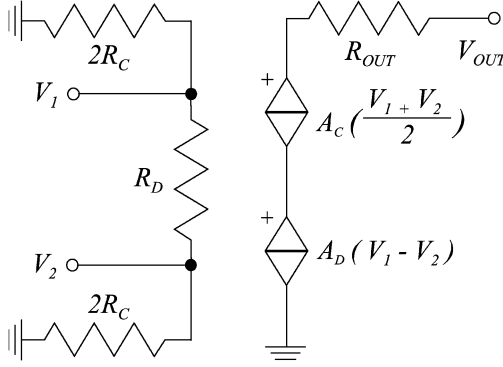

Fig. 2. Operational amplifier equivalent circuit.

tial, common, and single-ended mode as reported in the following expression:

$$\overset{\circ}{\mathbf{S}} = \begin{pmatrix} \overset{\circ}{\mathbf{S}}_{dd} & \overset{\circ}{\mathbf{S}}_{dc} & \overset{\circ}{\mathbf{S}}_{de} \\ \overset{\circ}{\mathbf{S}}_{cd} & \overset{\circ}{\mathbf{S}}_{cc} & \overset{\circ}{\mathbf{S}}_{ce} \\ \overset{\circ}{\mathbf{S}}_{ed} & \overset{\circ}{\mathbf{S}}_{ec} & \overset{\circ}{\mathbf{S}}_{ee} \end{pmatrix} \quad (37)$$

where the d, c, and e sub-matrix subscripts refer to the differential, common, and single-ended modes, respectively.

IV. EXAMPLE

The operational amplifier is a typical simple case of a circuit with two input coupled ports and a single-ended output port. To properly study this circuit, we adopt the simplified model shown in Fig. 2. The reference impedance for the two input ports is assumed unique (R_0), however, different from the one of the output port (R_3). With this assumption, the 3×3 single-ended \mathbf{S} matrix has the following elements:

$$\begin{aligned} S_{11} = S_{22} &= \frac{4R_C^2 R_D - R_0^2 R_D - 4R_0^2 R_C}{(2R_C + R_0)(R_0 R_D + 4R_0 R_C + 2R_C R_D)} \\ S_{13} = S_{23} &= 0 \\ S_{33} &= \frac{R_{OUT} - R_3}{R_{OUT} + R_3} \\ S_{12} = S_{21} &= \frac{8R_C^2 R_0}{(2R_C + R_0)(R_0 R_D + 4R_0 R_C + 2R_C R_D)} \\ S_{31} = S_{32} &= \frac{2R_C \sqrt{R_0 R_3}}{R_{OUT} + R_3} \\ &\times \left(\frac{A_C}{2R_C + R_0} + \frac{2A_D R_D}{R_0 R_D + 4R_0 R_C + 2R_C R_D} \right). \end{aligned} \quad (38)$$

As expected from the classical single-ended approach, the information regarding the differential and common mode amplification is all together embedded within the S_{31} - and S_{32} -parameters, and the common and differential contributions cannot be

easily recognized and separated. Using the above results, it is simple to transform \mathbf{S} into the corresponding new mixed-mode $\overset{\circ}{\mathbf{S}}$ matrix. In this particular case, the sub-matrices defined in (37) are simply the elements of $\overset{\circ}{\mathbf{S}}$, and are given by

$$\begin{aligned} \overset{\circ}{S}_{12} = \overset{\circ}{S}_{13} = \overset{\circ}{S}_{21} = \overset{\circ}{S}_{23} &= 0 \\ \overset{\circ}{S}_{11} &= \frac{4R_C R_D - 4R_{d12} R_C - R_{d12} R_D}{4R_C R_D + 4R_{d12} R_C + R_{d12} R_D} \\ \overset{\circ}{S}_{22} &= \frac{R_C - R_{c12}}{R_C + R_{c12}} \\ \overset{\circ}{S}_{33} &= \frac{R_{OUT} - R_3}{R_{OUT} + R_3} \\ \overset{\circ}{S}_{31} &= \frac{8A_D \sqrt{2R_3 R_{d12}} R_D R_C}{(4R_C R_D + 4R_{d12} R_C + R_{d12} R_D)(R_{OUT} + R_3)} \\ \overset{\circ}{S}_{32} &= \frac{2A_C \sqrt{2R_3 R_{c12}} R_C}{(R_C R_{c12})(R_{OUT} + R_3)}. \end{aligned} \quad (39)$$

The differential and common mode amplifications are separated as highlighted by (39) that show the absence of cross-mode components at the operational amplifier output. Furthermore, the elements $\overset{\circ}{S}_{31}$ and $\overset{\circ}{S}_{32}$ only depend on A_D and A_C , respectively, showing in the most straightforward way the separated contributions of the input differential and common mode to the single-ended output port. Proceeding with some simplifications: matched output port and a common reference impedance for all ports ($R_{OUT} = R_3 = R_0$), we find

$$\begin{aligned} \overset{\circ}{S}_{12} = \overset{\circ}{S}_{13} = \overset{\circ}{S}_{21} = \overset{\circ}{S}_{23} = \overset{\circ}{S}_{33} &= 0 \\ \overset{\circ}{S}_{11} &= \frac{4R_C R_D - 4R_{d12} R_C - R_{d12} R_D}{4R_C R_D + 4R_{d12} R_C + R_{d12} R_D} \\ \overset{\circ}{S}_{22} &= \frac{R_C - R_{c12}}{R_C + R_{c12}} \\ \overset{\circ}{S}_{32} &= A_C \sqrt{\frac{2R_{c12}}{R_0}} \frac{R_C}{R_C + R_{c12}} \\ \overset{\circ}{S}_{31} &= A_D \sqrt{\frac{2R_{d12}}{R_0}} \frac{4R_C R_D}{4R_C R_D + 4R_C R_{d12} + R_{d12} R_D}. \end{aligned} \quad (40)$$

Finally, assuming the traditional mixed-mode reference impedances $R_{d12} = R_D = 2R_0$, $R_{c12} = R_C = R_0/2$, we find

$$\overset{\circ}{\mathbf{S}} = \begin{pmatrix} -\frac{1}{3} & 0 & 0 \\ 0 & 0 & 0 \\ \frac{2A_D}{3} & \frac{A_C}{2} & 0 \end{pmatrix}. \quad (41)$$

This expression points out once more the effectiveness of the proposed approach, compared with the traditional one based on the classical single-ended S -parameters, which, in the same conditions, would have given

$$\mathbf{S} = \begin{pmatrix} -\frac{1}{6} & \frac{1}{6} & 0 \\ \frac{1}{6} & -\frac{1}{6} & 0 \\ \frac{A_C}{4} + \frac{A_D}{3} & \frac{A_C}{4} - \frac{A_D}{3} & 0 \end{pmatrix}. \quad (42)$$

$$\mathbf{X}_{jk} = \begin{pmatrix} \frac{2Z_j^* + Z_{djk}}{4\sqrt{R_j R_{djk}}} & \frac{2Z_j - Z_{djk}}{4\sqrt{R_j R_{djk}}} & -\frac{2Z_k^* + Z_{djk}}{4\sqrt{R_k R_{djk}}} & -\frac{2Z_k - Z_{djk}}{4\sqrt{R_k R_{djk}}} \\ \frac{2Z_j^* - Z_{djk}}{4\sqrt{R_j R_{djk}}} & \frac{2Z_j + Z_{djk}}{4\sqrt{R_j R_{djk}}} & -\frac{2Z_k^* - Z_{djk}}{4\sqrt{R_k R_{djk}}} & -\frac{2Z_k + Z_{djk}}{4\sqrt{R_k R_{djk}}} \\ \frac{Z_j^* + 2Z_{cjk}}{4\sqrt{R_j R_{cjk}}} & \frac{Z_j - 2Z_{cjk}}{4\sqrt{R_j R_{cjk}}} & \frac{Z_k^* + 2Z_{cjk}}{4\sqrt{R_k R_{cjk}}} & \frac{Z_k - 2Z_{cjk}}{4\sqrt{R_k R_{cjk}}} \\ \frac{Z_j^* - 2Z_{cjk}}{4\sqrt{R_j R_{cjk}}} & \frac{Z_j + 2Z_{cjk}}{4\sqrt{R_j R_{cjk}}} & \frac{Z_k^* - 2Z_{cjk}}{4\sqrt{R_k R_{cjk}}} & \frac{Z_k + 2Z_{cjk}}{4\sqrt{R_k R_{cjk}}} \end{pmatrix} \quad (44)$$

V. CONCLUSIONS

This paper has presented an innovative approach that introduces the generalized mixed-mode *S*-parameters starting from the single-ended ones. These novel parameters allows for a consistent representation of networks with differential and single-ended ports with real or complex reference impedances. The new approach is fully consistent with the classical mixed-mode *S*-parameter theory when the required simplifications are applied. The method effectiveness, together with its capability to immediately identify the common and differential mode effects, has been proven on a test circuit having both classical single-ended and mixed-mode ports.

APPENDIX

Alternative definitions to (7) and (10) have been proposed by [2]

$$a \equiv \frac{V + IZ}{2\sqrt{R}} \quad b \equiv \frac{V - IZ}{2\sqrt{R}} \quad (43)$$

where *Z* is the normalization impedance and *R* is its real part. Despite these definitions have been demonstrated to be incompatible with the experimental data in presence of complex normalization impedances [5] (e.g., when *TRL* calibration on dispersive media is adopted), they are rather popular, and reduce to (7) for real normalization impedances. The only variations on the formulation concern the matrix \mathbf{X}_{jk} that have to be evaluated according to (43), and becomes (44), shown at the top of this page.

REFERENCES

[1] D. Bockelman and W. R. Einsenstadt, "Combined differential and common-mode scattering parameters: Theory and simulation," *IEEE Trans. Microw. Theory Tech.*, vol. 43, no. 7, pp. 1530–1539, Jul. 1995.
 [2] K. Kurokawa, "Power waves and scattering matrix," *IEEE Trans. Microw. Theory Tech.*, vol. MTT-13, no. 3, pp. 194–202, Mar. 1965.

[3] D. Bockelman and W. R. Einsenstadt, "Pure-mode network analyzer for on-wafer measurements of mixed-mode *S*-parameters of differential circuits," *IEEE Trans. Microw. Theory Tech.*, vol. 45, no. 7, pp. 1071–1077, Jul. 1997.
 [4] A. Ferrero, U. Pisani, and K. Kerwin, "A new implementation of a multiport automatic network analyzer," *IEEE Trans. Microw. Theory Tech.*, vol. 40, no. 11, pp. 2078–2085, Nov. 1992.
 [5] R. Marks and D. Williams, "A general waveguide circuit theory," *J. Res. Nat. Inst. Standards Technol.*, vol. 97, pp. 533–561, Sep. 1992.
 [6] —, "Characteristic impedance determination using propagation constant measurement," *IEEE Microw. Guided Wave Lett.*, vol. 1, no. 6, pp. 141–143, Jun. 1991.
 [7] G. Golub and C. V. Loan, *Matrix Computations*, 2nd ed. Baltimore, MD: The John Hopkins Univ. Press, 1989.



Andrea Ferrero (S'86–M'88) was born in Novara, Italy, on November 7, 1962. He received the Electronic Engineering degree and Ph.D. degree in electronics from the Politecnico di Torino, Turin, Italy, in 1987 and 1992, respectively.

In 1988, he joined Aeritalia as a Microwave Consultant. In 1991, he was a Summer Student with the Microwave Technology Division, Hewlett-Packard Company, Santa Rosa, CA. In 1995, he was a Guest Researcher with the Electrical Engineering Department, Ecole Polytechnique de Montréal, Montréal, QC, Canada. In 1998, he became an Associate Professor of electronic measurements with the Politecnico di Torino. His main research activities are in the area of microwave measurements techniques, calibration, and modeling.



Marco Pirola (M'97) was born in Velezzo Lomellina, Italy, in 1963. He received the Laurea degree in electronic engineering and Ph.D. degree from the Politecnico di Torino, Turin, Italy, in 1987 and 1992 respectively.

In 1992 and 1994, he was a Visiting Researcher with the Microwave Technology Division, Hewlett-Packard Company, Santa Rosa, CA. Since 1992, he has been with the Dipartimento di Elettronica, Politecnico di Torino, initially as a Researcher and, since 2000, as an Associate Professor. His research concerns the simulation, modeling, and measurements of microwave devices and systems.