

A Traveling Standard for the Calibration of Data Acquisition Boards

Alessio Carullo, Marco Parvis, *Senior Member, IEEE*, and Alberto Vallan

Abstract—The large use of measurement systems based on data acquisition boards makes the traceability-chain assurance a tricky problem due to the difficulty in consistently calibrating such boards. In this paper, the authors describe a traveling standard which can be used for the calibration of many commercially available acquisition boards. By employing such a traveling standard, the calibration procedure can be remotely exercised by a calibration laboratory through the personal computer which hosts the board that has to be calibrated. In such a way, the calibration results refer to environmental, software, and hardware conditions that exactly match the board-operating conditions. Furthermore, the board unavailability time is drastically reduced, with a consequent economic advantage for the board owner. The traveling standard is based on a microcontroller which is responsible for the communication with the PC that hosts the board and for the board-stimulus generation, and on a digital multimeter, which acts as a reference standard.

Index Terms—Calibration, intelligent systems, interconnected systems, internetworking, standard.

I. INTRODUCTION

THE INCREASING complexity of industrial plants has generated the need to control and, hence, to measure several different quantities such as, for example, temperatures, pressures, and forces. These quantities are often sensed by means of electric-output transducers connected to data acquisition boards plugged into a personal computer (PC). Some problems arise when these systems have to be calibrated, as the effect of the two main sections that compose the measurement system (hardware of the acquisition board and driver and processing software) cannot be easily previewed.

Presently, the solution adopted for the calibration of data acquisition boards consists of removing the board from the PC where it normally operates and sending it to a calibration laboratory (CAL-LAB). At the CAL-LAB, the board is installed and calibrated in a PC that embeds a software which is able to exercise the board [1]. Though convenient for the CAL-LAB, this procedure suffers from two main drawbacks.

- The PC, which is employed to test the board, does not necessarily have the same hardware and software configuration of the PC on which the board usually works, the calibration results could not match the board performance during its normal operations.

- The calibration phase is performed in environmental and electromagnetic conditions that could be different from those occurring during the board use.

For this reason, a calibration of the acquisition board in the operating conditions would be preferable. A possible solution would be a conventional calibration of the board performed at user site, but such a solution would require the transfer of the standards and of a skilled technician to the site where the board normally operates, thus dramatically increasing the overall calibration cost.

This paper describes a different approach, which is based on a remote exercised calibration procedure and employs a traveling standard which is designed to be controlled through the Internet by the CAL-LAB. This kind of solution, already investigated at National Institute of Standards and Technology (NIST) for the calibration of multifunction calibrators [2], eliminates possible transport effects on the board performance and drastically reduces calibration cost and board unavailability time.

II. REMOTE CALIBRATION SYSTEM

The proposed remote-calibration system is based on a client-server application over the Internet and on a traveling standard, as shown in Fig. 1.

A. Traveling Standard

The traveling standard, whose block scheme is shown in Fig. 1, is made up of two main parts: a board based on a microcontroller (μC : PIC16LF877) and a digital multimeter (DMM). The traveling standard communicates with the PC that hosts the device under calibration (DUC PC) through the commonly available RS-232 interface. The μC board embeds a programmable voltage generator with two independent 16-bit digital-to-analog converters [(DACs) DAC1 and DAC2: Burr Brown PCM56], a switch board, and a nonvolatile RAM. The μC sets the two DACs and the switch board that routes the DAC outputs to the input channels of the DAQ board and to the DMM inputs. The stimuli the DACs provide are contemporaneously measured by DAQ board and DMM, which, hence, acts as the reference standard. The DMM also measures the signals provided by the DAQ board during the verification of the board outputs. The μC communicates with the DMM through an RS-232 interface. An analog input channel of the μC is employed to acquire the temperature at the DUC-PC site, which is measured by means of a solid state device.

The calibration results are sent through the Internet to the CAL-LAB PC, where they are stored into a data file, and are also stored into the nonvolatile RAM as an additional precaution.

Manuscript received June 15, 2001; revised August 1, 2003.

The authors are with the Dipartimento di Elettronica, Politecnico di Torino, Torino, Italy.

Digital Object Identifier 10.1109/TIM.2003.820448

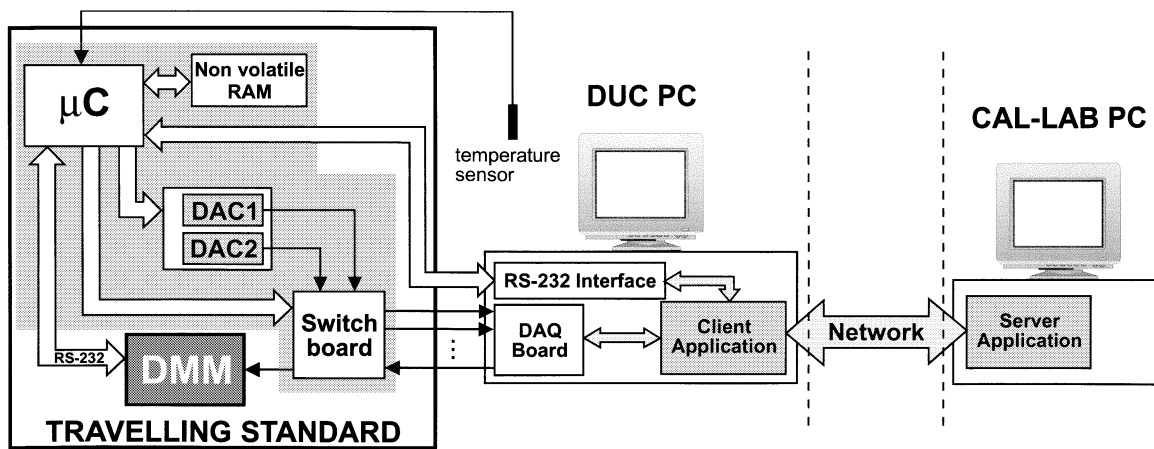

Fig. 1. Architecture of the remote-calibration system and block scheme of the traveling standard.

The DMM has been chosen in order to ensure a suitable ratio between the DAQ-Board uncertainty and the DMM uncertainty in every testing point [the so-called test uncertainty ratio (TUR)] [3]. The prototype the authors have arranged employs a 6.5-digit multimeter (Agilent Technologies model 34401A), which embeds an RS-232 interface and ensures a basic standard uncertainty of 7 ppm during dc-voltage measurements. This allows the calibration of DAQ board up to 14 bits of accuracy to be performed, i.e. the most of the 16-bit-resolution commercial boards. Fig. 2 shows a photograph of the traveling-standard prototype, which is able to provide output voltages in the range from -20 to $+20$ V.

B. Client-Server Application

The client-server application of the remote calibration system, which has been developed in Java, has the architecture shown in Fig. 3.

The DUC PC, where the client application runs, accesses the Internet through a provider either with a static or a dynamic IP address, while the CAL-LAB PC has a static IP address, in which the client application employs to establish the connection with the server application. Both applications employ the Java class `SSLsocket` that employs the SSL protocol [4] in the client-server communication over the Internet. The data encryption provided by the SSL protocol allows confidentiality and integrity of information to be obtained and provides a method to authenticate and certify the client.

The instructions the server sends to the traveling standard are also encrypted by means of a symmetric protocol; the decryption protocol is implemented by the μC inside the traveling standard. The same protocol is employed to encrypt data the traveling standard returns to the server application, e.g., DMM measurements and temperature at the DUC-PC site. This protection prevents a malicious intruder from intercepting the information that traveling standard and DUC PC exchange.

A further risk is due to an unauthorized user who could install a program that impersonates the DAQ board on the DUC PC. The program could be able to completely simulate the board and hence to generate false answers. Such a risk is minimized by employing a cyclic redundancy check (CRC) algorithm, which

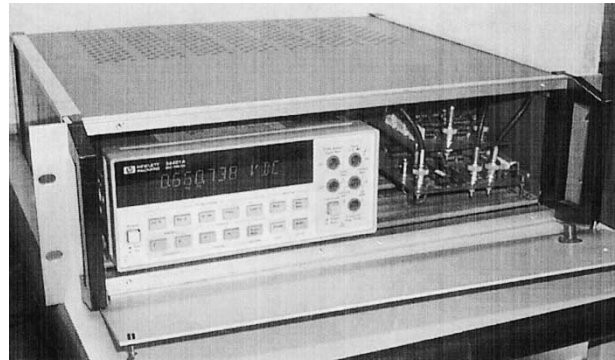

Fig. 2. Photograph of the traveling-standard prototype.

computes a signature of the PC software-configuration during the calibration procedure. The signature is computed by processing a configuration list obtained by a series of calls to functions of the application program interface (API) of the Windows operative system. The configuration list includes information about the programs installed on the DUC PC so that the PC signature changes when the impersonation program is removed. The calibration certificate of the DAQ board states this PC signature so that its change invalidates the certificate.

The access to the hardware devices is managed through two independent modules. A Java Native Interface (JNI) DLL has been implemented that gives a link to the manufacturer DAQ-board driver, while the Java Communications API have been used to write a communication application for the RS-232 serial port.

The instruction sequences that code the calibration procedures of different DAQ boards are stored into Command Files. The calibration management module at the CAL-LAB PC needs only to load the file which is relevant for the board to be calibrated and to start its execution. Each command file contains four types of messages, which implement a handshake process that terminates with an acknowledge message from the DUC-PC. The message types are as follows.

- Send-Ack: messages sent to the DUC PC, which configures the traveling standard and the acquisition board. The DUC-PC sends back the acknowledge message only after the operation has been completely executed.

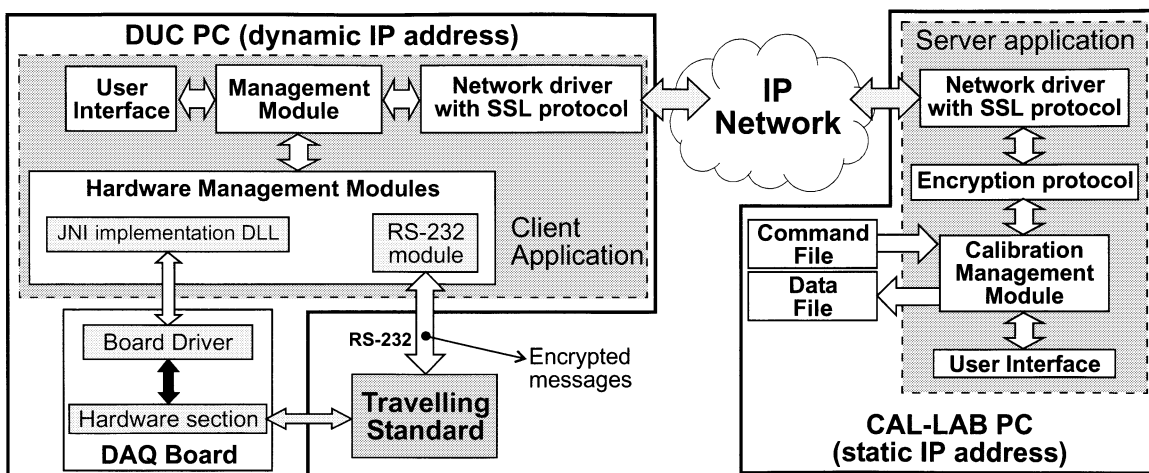

Fig. 3. Architecture of the client-server application over the Internet.

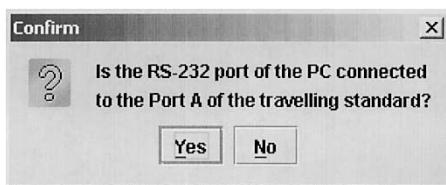

Fig. 4. Example of dialog box that shows an instruction message.

- Send-Query-Ack: messages that allow the CAL-LAB PC to send warnings and instructions to the DUC-PC that are shown by means of dialog boxes (see Fig. 4 for an example of connection instruction).
- Send-Query-Data: messages that are sent to the DUC PC in order to require any kind of information, as the measurements carried out by DMM, acquisition board, and temperature sensor or configuration and identification parameters. In this case, the acknowledge function is provided by the data the CAL-LAB PC receive.
- Loc-Wait and Rem-Wait: messages that are employed to pause the calibration procedure under particular circumstances, e.g., during the thermal stabilization of a measurement connection. In this case, the acknowledge message is sent after the requested interval is elapsed.

Two text areas are available on both client and server application, as shown in Fig. 5, that allows messages to be sent/received asynchronously with respect to the automatic calibration procedure. This is intended to recover the calibration procedure from anomalous behaviors.

III. CALIBRATION PROCEDURE

A. Preliminary Phase

When a user requires the remote-calibration service to the CAL-LAB, it has to specify model and driver of the board under calibration. According to this information, the CAL-LAB customizes the Command File and the JNI DLL that accesses to the DAQ-board driver. The next step is the calibration of the DMM and a trail-run of the μ C board, which is intended to verify the correct behavior of the traveling standard.

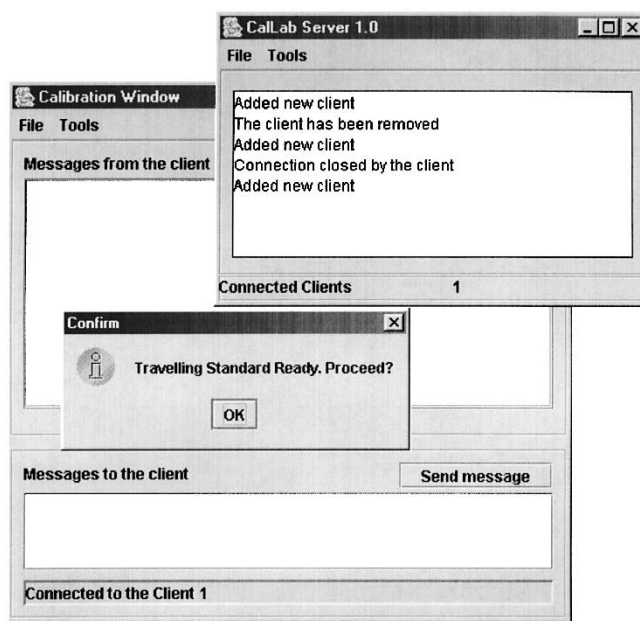

Fig. 5. Frames of the server application at the CAL-LAB PC.

Eventually, the CAL-LAB delivers the traveling standard to the user, which has to install the client application on the DUC PC. Such an application must remain on the DUC PC also after the calibration is performed in order to avoid the modification of the CRC signature.

B. Operative Phase

Fig. 5 shows the frame of the Java classes CalLab Server, which implements a thread that waits for a client connection request over the Internet. The client-application frame contains a button that allows a connection request to the server to be performed. When a request arrives, the listen thread creates a new instance of the class calibration, whose frame is also shown in the figure. Such a class implements a thread that manages the communication with the client application.

Once the communication is established, the server application tests the communication channel with the traveling standard; the “confirm” message shown in the Fig. 5 is sent to the CAL-LAB

PC if the traveling standard is correctly running. The next operation is the identification of the DAQ board, by means of its model and serial number, and the DUC-PC configuration, which is summarized by means of the CRC signature (see Section II).

Then, the calibration procedure is performed, which depends on the DAQ-board capabilities. Modern DAQ boards employ several calibration constants, which are stored inside a non-volatile on-board memory, in order to convert the output code of the on-board analog-to-digital converter (ADC) into a voltage value. These kinds of boards usually allow an adjustment procedure to be performed, which automatically modifies the calibration constants and removes voltage offsets in order to bring the board back within specification. In this case, the calibration procedure consists of an initial verification, an adjustment and a final verification, and the calibration results are stated in terms of voltage values.

For acquisition boards that do not embed the adjustment capability, only a verification is performed and the calibration results are given in terms of output code of the on-board ADC.

Initial and possible final verification can be performed in two different ways, depending on the board functionality that has to be verified. The majority of acquisition-board manufacturers recommend a basic procedure, which consists of the verification of one single-ended input channel and of the possible single-ended output channels. In this case, only the DAC1 is involved and the measurements of DMM, DAQ board, and temperature sensor are acquired. An enhanced procedure, which employs both the traveling-standard DACs, can be performed in order to verify the crosstalk between single-ended input channels and to test one or more differential inputs.

In the present implementation, the traveling standard is able to calibrate DAQ board up to 12 single-ended input channels, six differential input channels, and two output channels.

C. Final Phase

As soon as the traveling standard arrives back at the CAL-LAB, the DMM is verified and a comparison between the traveling-standard memory contents and the data uploaded during the calibration procedure is performed. If these operations do not show any problems, the calibration certificate is issued, which states, for every calibration point, the amplitude of the stimulus applied to the DAQ board (DMM measurement), the DAQ-board measurement, the calibration uncertainty, and the test conditions (single-ended input with or without crosstalk, or differential input, ...). The calibration certificate also contains the board serial-number and the DUC-PC signature.

The calibration certificate states the DUC performance in the conditions met during the calibration procedure. Every difference with respect to such conditions, e.g., different versions of software modules included in the DUC-PC configuration list or new software or hardware that can interact with the board driver, invalidates the certificate. This situation is highlighted by using the client application "offline" to compare the actual DUC-PC signature with that computed during the calibration procedure.

IV. CONCLUSION

The remotely-exercised traveling standard proposed in this paper allows the calibration of DAQ boards to be performed on the PC where the boards normally operate. This solution has the main advantage of avoiding a problem that is under discussion within the main accreditation bodies, which refers to the validity of the calibration of a DAQ board when it works on a PC that is different from that employed during the calibration. Furthermore, a drastic reduction of the board unavailability-time and, hence, an economic advantage for the board owner, is obtained.

The remote calibration is managed thanks to a client-server application, whose architecture has been designed in order to obtain high flexibility and modularity. The calibration of a new DAQ board requires only the development of a new command file and a new DLL that implements the JNI interface for the new manufacturer DAQ-board driver.

Tests have shown the functionality of the overall calibration system when the DUC PC and CAL-LAB PC are within a local area network.

REFERENCES

- [1] National Instrument Calibration Support, National Instruments. <http://www.ni.com/support/calibrat/calcert.htm> [Online]
- [2] N. Oldham and M. Parker, "Internet-based test service for multifunction calibrators," in *Proc. 16th IEEE Instrumentation Measurement Technology Conf.*, vol. 3, pp. 1485-1487.
- [3] *Calibration: Philosophy in Practice*, 2nd ed. Everett, WA: Fluke Corporation, 1994.
- [4] P. Karlton, A. Frier, and P. Kocher, "The ssl 3.0 Protocol," *Tech. Rep.*, Nov. 1996.

Alessio Carullo was born in Italy in 1966. He received the M.S. degree in electronic engineering from the Politecnico di Torino, Torino, Italy, in 1992 and the Ph.D. degree in electronic instrumentation from the Università di Brescia, Brescia, Italy, in 1997.

He is currently an Assistant Professor with the Dipartimento di Elettronica, Politecnico di Torino, where, since 1998, he has been responsible for the Department Calibration Laboratory (SIT Calibration Center n. 139). His main fields of interest are the development and characterization of intelligent instrumentation and systems for power measurements in distorted environment. He is with the working group SIT-GE/GL1 for the validation of automatic calibration systems.

Marco Parvis (M'97-SM'01) was born in Italy in 1958. He received the M.S. degree in electrical engineering and the Ph.D. degree in metrology from the Politecnico di Torino, Torino, Italy, in 1982 and 1987, respectively.

He is currently a Professor of electronic measurements at the Politecnico di Torino. His main fields of interest are intelligent instrumentation, signal processing, and biomedical measurements. He is working now on new sensors for mechanical and chemical quantities and on the development of distributed measuring systems.

Alberto Vallan was born in Italy in 1967. He received the M.S. degree in electronic engineering from the Politecnico di Torino, Torino, Italy, and the Ph.D. degree in electronic instrumentation from the Università di Brescia, Brescia, Italy.

He is currently an Assistant Professor with the Electronic Department, Politecnico di Torino. His main fields of interest are power measurement in distorted environments, the development of sensors for physical and chemical quantities, and intelligent measurement systems.