



**Queensland University of Technology**  
Brisbane Australia

This is the author's version of a work that was submitted/accepted for publication in the following source:

Xiong, Bo, Skitmore, Martin, Xia, Bo, Masrom, Md Asrul, Ye, Kunhui, & Bridge, Adrian

(2013)

Examining the influence of participant performance factors on contractor satisfaction : a structural equation model.

*International Journal of Project Management*, 32(3), pp. 482-491.

This file was downloaded from: <https://eprints.qut.edu.au/60641/>

© Copyright 2013 Please consult the authors.

**Notice:** *Changes introduced as a result of publishing processes such as copy-editing and formatting may not be reflected in this document. For a definitive version of this work, please refer to the published source:*

<https://doi.org/10.1016/j.ijproman.2013.06.003>

---

# **Examining the influence of participant performance factors on contractor satisfaction: A structural equation model**

Bo Xiong<sup>1,\*</sup>, Martin Skitmore<sup>1</sup>, Bo Xia<sup>1</sup>, Md Asrul Masrom<sup>2</sup>, Kunhui Ye<sup>3</sup>, Adrian Bridge<sup>1</sup>

<sup>1</sup> School of Civil Engineering and Built Environment, Queensland University of Technology, Gardens Point, Brisbane QLD, 4001, Australia.

<sup>2</sup> Department of Construction and Real Estate Management, Faculty of Technology Management, Business and Entrepreneurship, University Tun Hussein Onn Malaysia (UTHM), 86400, Parit Ra, Malaysia.

<sup>3</sup> Faculty of Construction Management and Real Estate, Chongqing University, Chongqing, 400045, China.

\* Corresponding author

Email address:

[peterxiongbo@gmail.com](mailto:peterxiongbo@gmail.com) (Bo Xiong)

[rm.skitmore@qut.edu.au](mailto:rm.skitmore@qut.edu.au) (Martin Skitmore)

[paul.xia@qut.edu.au](mailto:paul.xia@qut.edu.au) (Bo Xia)

[asruln@uthm.edu.my](mailto:asruln@uthm.edu.my) (MA. Masrom)

[kunhui.ye@gmail.com](mailto:kunhui.ye@gmail.com) (Kunhui Ye)

[a.bridge@qut.edu.au](mailto:a.bridge@qut.edu.au) (Adrian Bridge)

---

## Abstract

Participant performance is critical to the success of projects. At the same time, enhancing the satisfaction of participants not only helps in problem solving but also improves their motivation and cooperation. However, previous research related to participant satisfaction is primarily concerned with clients and customers and relatively little attention has been paid to contractors.

This paper investigates how the performance of project participants affects contractor project satisfaction in terms of the client's clarity of objectives (OC) and promptness of payments (PP), designer carefulness (DC), construction risk management (RM), the effectiveness their contribution (EW) and mutual respect and trust (RT). With 125 valid responses from contractors in Malaysia, a contractor satisfaction model is developed based on structural equation modelling.

The results demonstrate the necessity for dividing abstract satisfaction into two dimensions, comprising economic-related satisfaction (ES) and production-related satisfaction (PS), with DC, OC, PP and RM having significant effects on ES, while DC, OC, EW and RM influence PS. In addition, the model tests the indirect effects of these performance variables on ES and PS. In particular, OC indirectly affects ES and PS through mediation of RM and DC respectively. The results also provide opportunities for improving contractor satisfaction and supplementing the contractor selection criteria for clients.

**Keywords:** Contractor satisfaction, structural equation model, project success, satisfaction dimensions, participant performance factors.

## 1. Introduction

The construction industry plays an important role in providing employment opportunities and enhancing economic development, especially in developing countries such as China, India, and Malaysia (Doloi et al. 2012; Ye and Xiong 2011; Yong and Mustafa 2012). However, the industry has a poor record for project success in terms of cost, time and quality, etc. Participant satisfaction is a crucial aspect of this, as noted by Al-Tmeemy et al. (2011) and Leung et al. (2004), in addition to qualified project completion.

Participant satisfaction describes the level of “happiness” of project participants and slow decisions made by clients, poor labour productivity, and architects' reluctance to change, for example, contribute to both reduced satisfaction and unsuccessful projects (Doloi et al. 2012). Enhanced satisfaction, therefore, not only helps to improve motivation and cooperation among participants but also increases the likelihood of successful project completion, making its evaluation important in judging the success or otherwise of a project.

Construction contractors are responsible for the actual production work involved (cost management, schedule management, quality management etc.) in projects and so their performance is critical to success of projects. Furthermore, replacing a contractor with another during project execution is very costly. It is therefore important to

---

understand the factors influencing contractor performance, and measuring the degree of contractor satisfaction offers a means of achieving this as well as providing an opportunity to enhance the effectiveness of cooperation between contractors and other participants. That is to say, contractor satisfaction is central to maintaining the cohesiveness and level of teamwork needed for a project (Chan et al 2002).

Previous satisfaction research in construction, however, is concerned much more with the satisfaction of clients and customers than that of contractors. In addition, current limited studies on measuring contractor satisfaction consider only the effects of client behaviour and regard satisfaction holistically (Soetanto and Proverbs 2002). A more detailed, multi-dimensional account of contractor satisfaction will take into account the behaviour of the different participants involved.

Structural equation modelling (SEM) enables this to be done. Developed from data collected by a postal survey of Malaysian construction contractors, a structural equation model demonstrates that project participants appear to fundamentally influence contractor satisfaction on two dimensions: economic-related satisfaction and production-related satisfaction. Corresponding hypotheses are also developed and tested by applying SEM, describing the causal relationships involved in terms of satisfaction dimensions and associated participant performance factors.

## **2. Literature Review**

The concept of customer satisfaction emerged in the early 1980s in the USA and subsequently widely used in the fields of psychology, business, marketing and economics (Liu and Leung 2002). Defined as the response to the difference between 'How much is there?' and 'How much should there be?' (Wanous and Lawler 1972), satisfaction is particularly useful in the measurement of performance outcomes (Nerkar et al. 1996).

In the construction industry, the term 'satisfaction' has become progressively used over the past decade, its increased attention being taken to indicate a positive change from a pure focus on business performance to a greater emphasis on stakeholder performance (Love and Holt 2000). Therefore, in addition to the traditional objective outcome measures of time, cost and quality, measuring satisfaction has become another effective way of helping to improve project performance, especially for large and complex projects (Cheng et al. 2006; Ling et al. 2008; Toor and Ogunlana 2010). Furthermore, satisfaction can boost repeat business and increase long-term profitability (Wirtz 2001).

There exist a variety of applications of satisfaction measurement in the construction context. These comprise studies of client satisfaction levels associated with contractor and consultant performance (Cheng et al. 2006; Mbachu and Nkado 2006); customer satisfaction with the products and services of the industry (Maloney 2002; Yang and Peng 2008); and home buyer and occupant satisfaction in terms of comfort (Paul and Taylor 2008; Torbica and Stroh 2001). Leung (2004) also measures the degree of correlation between project participant satisfaction and potential contributing factors.

---

However, although there are studies measuring contractor performance, contractor satisfaction has received much less attention. The sole example to date is that of Soetanto and Proverbs (2002), who establish an overall contractor satisfaction regression equation based on responses from 80 top UK contractors. However, this is restricted to the measurement of contractor satisfaction exclusively in response to client behaviour. Extending this to accommodate the influence of other participants has yet to be undertaken.

Satisfaction in the construction industry is also viewed as a holistic entity in current research on client satisfaction, homebuyer satisfaction and contractor satisfaction (Cheng et al., 2006; Kärnä et al., 2009; Paul and Taylor 2008; Soetanto and Proverbs 2002). However, research conducted in the manufacturing industry demonstrates the importance of distinguishing economic satisfaction from non-economic satisfaction in manufacturer-distributor relationships (del Bosque Rodríguez et al., 2006). Although construction is uniquely different to manufacturing in many ways, the role of manufacturers in the production and transfer of products to the market via distributors has some similarity with the role of construction contractors, who construct and transfer products to clients directly or via the client to end users. It is likely, therefore, that construction contractor satisfaction will benefit from receiving a similar decomposition.

### **3. Research method**

To examine the influence of participant performance factors on contractor satisfaction, two main research methods are adopted: questionnaire survey and structural equation modelling (SEM). Eighteen hypotheses are first proposed according to the literature review. A conceptual model is then developed based on these hypotheses by SEM. In the questionnaire design, Keline's (2005) principle, which uses three measurement variables to reflect one latent variable, is applied in order to obtain a stable equation structural model. 125 complete and reliable responses collected from contractors in Malaysia comprise the basis for the data analysis.

#### *3.1. Hypotheses*

One conceptualisation of satisfaction is in the form of an input-process-output system where, although the internal process is still unknown, performance outcomes provide an input leading to satisfaction/dissatisfaction as the output (Soetanto and Proverbs 2002). Performance outcomes are determined by different construction project participants, with contractors, as performance assessors, having their own psychological interpretation of the performance levels of others (Soetanto and Proverbs 2002). Thus, the satisfaction of contractors is treated as being caused by participant performance.

The Construction Industry Development Board (CIDB), which was established by the Malaysian Federal Government in 1994 and is in charge of planning direction

---

of the industry, reported in its 2006-2015 construction industry plan that project failures are not solely caused by contractors, but also by other participants, such as the architect, engineer, subcontractors and suppliers (CIDB 2006). It is clear, therefore, that project success depends on the efforts of all participants, as unsatisfactory work by any one participant can lead to the failure of a whole project. In addition, delayed government projects in Malaysia are known to be due not only to the poor performance of contractors, but also to a lack of communication between participants, inadequate client finance and late provision of construction drawings by consultants (Sambasivan and Soon 2007).

Adapting del Bosque Rodríguez et al. (2006), contractor satisfaction is divided into two dimensions: economic-related satisfaction (ES) and production-related satisfaction (PS). The former dimension refers to contractor satisfaction with economic issues such as project cost, project profitability and potential business opportunities arising from current projects. In contrast, production-related satisfaction refers to contractor satisfaction with production quality, including project quality, safety and timely completion.

The measurement of contractor satisfaction should therefore take into account the effects of several participants. Perhaps the most important of these is the client, who plays an important role in both project completion and contractor satisfaction. Several infrastructure projects in Jordan, for example, have suffered in terms of delays due to client-related factors, including finance, payments for completed work, and slow decision making (Odeh and Battaineh 2002). Similarly, massive client-led changes in project scope have caused up to 70% poor time performance in Saudi Arabian projects (Assaf and Al-Hejji 2006). Also, Park's (2009)'s survey of 27 contractors found effective preplanning and client clarity of intention to be the most important factors affecting scope dimension and project success in South Korea. This suggests corresponding hypotheses of:

- H1: The client's clarity of objectives (OC) has a positive influence on ES.
- H2: OC has a positive influence on PS.
- H3: OC has a positive influence on DC
- H4: OC has a positive influence on construction risk management (RM).
- H5: The client's promptness of payment (PP) has a positive influence on ES.
- H6: PP has a positive influence on PS.

Suitable design is another crucial factor to project success, with contractors regarding defective design as a major risk in South Korea (Park 2009), for example, while accounting for 50% of quality failures in Malaysia (Plan 2006), leading to the corresponding hypotheses:

- H7: DC has a positive influence on ES.
- H8: DC has a positive influence on PS.

An increasing number of project uncertainties have a fundamental effect on project performance in the UK (Atkinson et al. 2006). These uncertainties lead to negative relationships between parties, conflicts, mismatched objectives and

---

adversarial relationships (Harmon 2003). Construction risk management provides a means of overcoming this to some extent and is therefore necessary to project success, with the corresponding hypotheses being:

- H9: RM has a significant influence on ES.
- H10: RM has a significant influence on PS.
- H11: RM has a positive influence on PP.
- H12: RM has a positive influence on the effectiveness of other project participants' work (EW)
- H13: RM has a positive influence on respect and trust among project participants (RT)

The ineffective contribution of other project participants is recognised as a major cause of project failure, being attributed to poor schedule performance in Saudi Arabia for example, particularly in public projects (Al-Kharashi and Skitmore 2009). Similarly, the performance of subcontractors and suppliers is also an important factor contributing to the success and quality of construction projects in Finland (Kärnä et al. 2009), giving rise to the corresponding hypotheses of:

- H14: EW has a positive influence on ES.
- H15: EW has a positive influence on PS.

Participant attitudes during the project are also very important in influencing collaborative work and service quality (Ling and Chong 2005; Soetanto and Proverbs 2002). Similarly, enhancing understanding and trust among project participants is beneficial in increasing the satisfaction levels of all participants (Lehtiranta et al. 2012). The corresponding hypotheses are:

- H16: RT has a positive influence on ES.
- H17: RT has a positive influence on PS.
- H18: RT has a positive influence on EW

All these hypotheses together comprise a conceptual model, which is also regarded as the structural component in the perspective of SEM, as illustrated in Figure 1.

<<Insert Figure 1 here>>

Figure 1: Structural component

### *3.2. Structural equation modelling*

The structural equation modelling (SEM) technique is widely used to explore and test causal relationships in the social sciences, such as in psychology, education and health. SEM is a combination of factor analysis, multiple correlation, regression and path analysis. Compared with other multivariate analysis methods, such as multiple regression and neural networks, SEM has the ability to (1) estimate multiple and interrelated dependence relationships; (2) represent unobserved concepts in these

---

relationships; (3) consider measurement errors in estimation; and (4) define a model explaining an entire set of relationships (Keline 2005; Cho et al. 2009).

Because of these advantages, SEM is being increasingly used in construction-related studies. For example, Islam and Faniran (2005) construct an SEM model to investigate three factors influencing project-planning effectiveness; Cho et al. (2009) use SEM to explore the effects of project characteristics on project performance; while Anvuur and Kumaraswamy (2012) investigate the effects of four job cognition variables on four cooperative behaviours. SEM is also recommended for increased use in the construction industry due to its suitability in solving construction-related problems (Oke et al. 2012). Likewise, SEM applied here aims to provide a way to investigate the effects of participant performance factors on two contractor satisfaction dimensions.

SEM describes the relationships between two kinds of variables: latent and observed. Latent variables cannot be observed directly due to their abstract character. In contrast, observed variables contain objective facts or use an item rating scale in a questionnaire. Several observed variables can reflect one latent variable (Byrne 2010; Mainul Islam and Faniran 2005). One structural equation model divides into two components: the measurement and the structural component. The measurement component consists of the measurement errors of the measurement variables and the relationships between observed variables and the represented latent variable. The structural component expresses the relationships among latent variables. Thus, a structural equation model consists of one structural component and several measurement components (Washington et al. 2011). A two-step modelling method is usually used to develop a structural equation model in preference to establishing the model directly (Anvuur and Kumaraswamy 2012; Byrne 2010). This comprises, first, a confirmatory factor analysis (CFA) followed by SEM. The aim of the CFA is to test the validity of the measurement components and provide the foundation for the next step. If the goodness of fit is satisfactory in the CFA phase, the next step is to replace the correlations between the latent variable with hypothesized causal relationships and then test the model.

Of course, as with all analyses of this kind, the existence of statistical correlation or association does not prove causation or influence but simply lends support to the logical or intuitive belief in their presence. Bearing this in mind, the word 'influence' denotes "appears to influence" rather than to indicate any irrefutable proof of such influence.

To apply SEM, many computer software systems, such as AMOS, EQS, LISREL, have been developed (Jyh-Bin and Shen-Fen 2008). Of these, the SPSS AMOS version 19 is used to construct and analyse the contractor satisfaction model. Based on SEM, Figure 1 shows the structural component composed of all the hypotheses that describe the direct relationships between two variables.

### *3.3. Questionnaire Survey*



---

The hypotheses shown in Figure 1 are tested according to Kline's three-variable principle, where three observed variables are used to reflect a latent variable (Kline 2005). To do this, the observed variables are extracted from Masrom's (2011) larger questionnaire of Malaysian contractors, formerly used to construct a multiple regression contractor satisfaction model from 95 contributing factors. Bearing in mind the requirement of high reliability and clear classification, both subjective methods (e.g. brainstorming) and statistic methods (e.g. reliability testing) were used to obtain the measurement framework as shown in Table 1.

<<Insert Table 1 here>>

### *3.4 Data*

The data comprise 125 responses from senior experienced personnel, with a 41.7% valid response rate. This is comparable with the previous SEM studies, e.g. Islam and Faniran (2005) with 52 cases (61% response rate), Cho et al's (2009) 151 cases and Anvuur and Kumaraswamy's (2012) 153 cases (18% response rate), while exceeding the minimum of 100 cases for SEM suggested by Gorsuch (1983) and Bagozzi and Yi (2012). Of the respondents, 17.6% companies have been in business for 1-5 years; 28% for 6-10 years; 20.8% for 11-15 years; 12% for 16-20 years; and 21.6 % companies for more than 20 years. Concerning company size, 53.6% are large companies (G7), and 46.4% are small to medium companies (G1-G6) according to the company size criteria and corresponding tendering capability in Malaysia (CIBD 2006). Table 2 describes the basic characteristics of the respondents, and further details are contained in Masrom (2011).

<<Insert Table 2 here>>

### *3.5. Reliability test*

Chronbach's alpha value is used to test the reliability of the hypothesized construct based on the data. If a Chronbach's alpha value is above 0.7, the received data is deemed to be acceptable for significant consistency (Cho et al. 2009; Doloï et al. 2012). As shown in Table 3, the items measured in eight variables and the overall construct are sufficiently reliable.

<<Insert Table 3 here>>

---

## 4. Results

A two-step method is used to develop the structural equation model. Confirmatory factor analysis (CFA) provides the first step, and demonstrates a satisfactory goodness of fit. Since the goodness of fit is satisfactory in the CFA phase, the next step replaces the correlations between the latent variables with hypothesized causal relationships as shown in Figure 1. Maximum likelihood estimation is used to conduct both steps.

### 4.1. Confirmatory factor analysis

The measurement components are similar in structure. For example, as shown in Figure 2, the client's clarity of objectives (OC) is reflected in three observed items: Q1-Q3; and their measurement errors. The observed variables are shown in rectangles, the latent variable in ellipses, measurement errors in circles and with arrows indicating the direction of effects. To identify a measurement component, one coefficient between the latent item and measurement items is given the value of unity firstly before calculating the next step of standardization (Keline 2005). Likewise, a starting value of unity is given between Q1 and OC. A dummy variable is used to denote company size, with 0=small/medium and 1=large contractors.

<<Insert Figure 2 here>>

Figure 2: Measurement component

Table 4 presents the standardized regression weights and squared multiple correlations (SMCs) for each observed item. Statically significant standardized regression weights of 0.5 or higher indicate good convergent validity (Anvur and Kumaraswamy 2012). In this case, all the regression weights (factor loadings) are highly significant and range from 0.65 to 0.93 with the SMCs ranging from 0.42 to 0.86. For example, the SMC for 'quality of project brief' (Q1) is 0.67, indicating that 67% of the variance in 'quality of project brief' is explained by 'client clarity of objectives' (OC).

<<Insert Table 4 here>>

Measuring the goodness of fit is an important part in developing structural equation models and a large number of goodness of fit criteria has been developed for this purpose (Washington et al., 2011). Generally, three types of model fit measures are used to judge the fitness of the measurement components: absolute fit, incremental fit and parsimonious fit (Ong and Musa 2012). Of these, Ong and Musa's criterion is used in this phase giving  $\chi^2 = 311.391$  (df = 235,  $\chi^2/df = 1.325$ ) (Table 5). As the  $\chi^2/df$  value is between 1 and 2, this indicates an excellent fit (Doloi et al. 2011).

<<Insert Table 5 here>>

---

#### 4.2. Structural equation modelling

As a 'good model' goodness of fit is obtained in the CFA phase, the correlations between the latent variables are replaced by hypothesized causal relationship as shown in Figure 1. The final model is shown in Figure 3, where the observed variables Q1 to Q24 are shown in rectangles; latent variables such as OC are shown in ellipses; with the arrows reflecting the hypothesized direction of effect. Figure 3 includes eight measurement components and the structural component which refers to all latent variables and their interrelationships shown in Figure 1. The measurement errors and factor loadings between the latent variables and measurement variables are not shown as they are very similar to those in Table 4. The company size variable continues to be dummy coded and is not shown. The standardized coefficients of the hypothesized causal relationships are shown, with the coefficients not significant at  $p < 0.05$  being shown in parentheses. The influence of company size variable on ES and PS is quite weak.

<<Insert Figure 3 here>>

Figure 3: Final SEM model results;

The SMC of ES in the model is 0.620, which indicates that 62% of the variance in ES is explained by the six performance predictors and the dummy coded company size variable. The SMC of PS is 0.713, indicating that 71.3% of the variance in ES is explained by the six performance predictors and the dummy coded company size variable. Both SMCs indicate usefulness in choosing contributing factors.

As can be seen in Figure 3, contractor satisfaction is significantly influenced by the client's clarity of objectives (OC) and promptness of payment (PP), designer carefulness (DC), construction risk management (RM) and effectiveness of the other project participants (EW). Respect and trust among project participants (RT) have no significant influence on economic-related satisfaction (ES) or on production-related satisfaction (PS), but appears to affect ES and PS via EW. RT has a positive effect on EW ( $r = 0.414$ ), which positively affects PS ( $r = 0.466$ ). However, a significant test of indirect effects is needed to assess this fully.

The concept of indirect effects or mediation is invoked to investigate this latter issue. In terms of the SEM model, if some variables act as mediators between X and Y, then X has both a direct effect on Y and an indirect effect on Y via the mediating factors. Figure 3 already shows the direct effects between variables in terms of the calculated coefficients. The Sobel test based on the work of Sobel (1982) determines the significance of mediation effects. The probability column of Table 6 summarises the results for the seven paths, together with the values of indirect effects in the corresponding column. Clearly, since  $RT \rightarrow EW \rightarrow PS$  and  $PR \rightarrow EW \rightarrow PS$  are not significant,  $OC \rightarrow RT \rightarrow EW \rightarrow PS$  and  $OC \rightarrow PR \rightarrow EW \rightarrow PS$  are also not significant.

<<Insert Table 6 here>>

---

## 5. Findings and discussion

The main research finding is that DC, OC and PP positively influence (have a positive influence on) ES while DC, EW and OC positively influence PS, with RM negatively influencing ES and PS. Also, other than H6, H14, H16 and H17, 14 hypotheses shown in Figure 1 are supported.

The model development results shown in Figure 3 support the hidden assumption that contractor satisfaction is caused by participant performance and that satisfaction is divisible into economic-related satisfaction (ES) and production-related satisfaction (PS). In addition, the performance variables have different effects on the two satisfaction dimensions, with client prompt payments (PP) having a positive effect on ES but no significant effect on PS. While the effectiveness of other project participants (EW) has a positive effect on PS but no significant effect on ES.

### 5.1. Client clarity of objectives (OC)

That OC positively influences ES ( $\beta=0.314$ ), PS ( $\beta=0.342$ ) supports the importance of clear objectives and demonstrates the positive relationship between clear objectives and contractor satisfaction. It confirms Park's (2009) finding that effective preplanning, clarity of contract and understanding of project requirements rank highest in measuring critical success and Leung et al's (2004) assertion that goal specificity is positively associated with goal commitment, which in turn is positively associated with construction participant satisfaction. OC also has a positive effect on DC ( $r=0.645$ ) and RM ( $r=0.525$ ). For indirect effects, OC influences ES (-0.311 and 0.367) by mediation of RM and DC respectively. Similarly, OC influences PS (-0.360 and 0.353) by mediation of RM and DC respectively.

### 5.2. Client's promptness of payment (PP)

PP is characterized by ease and speed of final account settlement, and promptness of progress payments made by the client. It has a positive effect on ES ( $\beta=0.211$ ), but its influence on PS is too weak to be significant. This confirms Yong and Mustaffa's (2012) result in which the financial capability of client ranks the 1st of 37 factors critical to project success in Malaysia, and Al-Kharashi and Skitmore's (2009) finding that lack of finance and delay in progress payments are critical factors for both clients and contractors in Saudi Arabian public projects. PP can ensure that the contractor obtains sufficient cash flow during and after construction, and this is probably why ES increases with PP. However, that the model does not show PP having a significant influence on PS may be attributed to production issues such as safety being influenced by government regulations etc.

---

### 5.3. Designer carefulness (DC)

DC refers to the quality of the designer's work, characterized by design constructability, comprehensiveness of design, and the flexibility of the design to accommodate changes in the measurement component. It is a key factor in the model, with the strongest positive effect on both ES ( $\beta=0.569$ ) and PS ( $\beta=0.548$ ) and supports H7 and H8 in which DC positively influences contractor satisfaction. This confirms the widely acknowledged importance of design (Al-Kharashi and Skitmore 2009; Park 2009; Yong and Mustaffa 2012). OC's positive influence on DC supports H3 and suggests that improving the clarity of project goals may also be beneficial in improving the quality of design.

### 5.4. Construction risk management (RM)

RM is usually a duty of contractors, and it is characterized by the efficiency of risk control, effectiveness of conflict management and appropriateness of sharing risks with other participants in the measurement component. As can be seen in Figure 3, RM is positively influenced by OC ( $r=0.525$ ), confirming that the level of risk management, associated with level of project uncertainty as Masrom (2011) notes, is largely related to project characteristics and client clarity of objectives. This is consistent with Siang and Ali (2012)'s findings that systematic risk management is not implemented actively by most of contractors in Malaysia and all three case companies, which are publicly listed in Malaysia, rate "avoid unsatisfactory projects and to enhance margins" as the least important of ten benefits of risk management (two selected 10th and one 9th). In view of this, it is not surprising to find that the model also indicates RM to have a strong negative effect on both ES ( $\beta=-0.592$ ) and PS ( $\beta=-0.686$ ), suggesting that contractors are unhappy with the effectiveness of their risk management despite it being critical to project success. This makes Soetanto and Proverbs' (2002) finding (that contractor satisfaction is negatively influenced by the perception that clients know exactly what they want) more understandable in that higher OC is associated with the lower ES and PS when mediated by RM. However, the model is more complex, with consideration of the direct effects of OC and indirect effects via DC and RM. Also of note is that RM is positively related to RT ( $r=0.721$ ) and EW ( $r=0.404$ ), both of which are critical to project success. That is to say, although risk management does not appear to bring satisfaction to contractors in Malaysia directly, it is already regarded as an important way of enhancing the productivity and harmony of participants.

### 5.5. Effectiveness of other project participants (EW)

EW is characterized by the efficiency of subcontractors in undertaking their work, supplier effectiveness in material supply and the productivity of project manpower, and has a significant effect on PS ( $\beta=0.466$ ). This confirms Yong and Mustaffa's (2012) finding that the allocation of manpower ranks as the most important

---

project-related factor critical to project success. On the other hand, EW does not have a strong effect on ES, which may be due to the price of work being based on workload rather than efficiency considerations.

#### *5.6. Respect and trust among project participants (RT)*

Atkinson et al. (2006) state that trust can be used as a way of reducing uncertainty, while enhancing trust is regarded as a better way to solve hidden problems in the construction process, with shared authorities among participants being a critical factor contributing to project success (Yong and Mustaffa 2012). This model confirms these findings in indicating that RT can enhance EW greatly ( $r=0.414$ ). Here, RT is characterized by the level of respect, understanding and trust among participants. However, as Figure 3 shows, although RT can contribute to project success, it does not have any significant effect on ES and PS. A similar phenomenon occurs with Leung et al.'s (2004) finding that correlations do not exist between the degree of participant satisfaction and their level of communication, or the amount of authority clients and project managers have in setting project goals.

### **6. Conclusions**

A framework is presented to measure construction contractor satisfaction, which comprises two satisfaction dimensions: economic-related satisfaction (ES) and production-related satisfaction (PS). This is used to develop a structural equation model to investigate how project participants' performance affects contractor satisfaction in terms of six factors: the client's clarity of objectives (OC) and promptness of payments (PP), carefulness of the designer (DC), construction risk management (RM), effectiveness of other project participants' work (EW) and respect and trust among project participants (RT). The findings confirm 14 hypotheses and deny 4 hypotheses. In particular, the results support the view that contractor satisfaction is a result of many participant effects and the six factors act differently on ES and PS.

Three important implications can be concluded from these results. Firstly, it is demonstrated that ES and PS provide a meaningful classification of contractor satisfaction and that each is affected differently by the six predictors. Of special note is that PP solely affects ES while EW solely affects PS. It is therefore necessary to examine the internal dimensions of contractor satisfaction before their measurement, as different types of satisfaction correlate differently with the different activities involved.

Secondly, the developed model offers a potential means of improving contractor satisfaction. For example, ES is influenced positively by OC, PP and DC, and negatively by RM. Thus a possible way to improve ES and enhance project success at the same time is for the client and designer to improve OC, PP and DC. Reducing RM, on the other hand, is counter-productive as RM positively related to EW and RT, both

---

important to project successful delivery. On the contrary, if construction risk management level needs to improve for assuring project success, it may be possible for the participants to combine to increase contractor satisfaction in other ways, such as by improving OC, PP and DC or OC, DC and EW. This reflects the delicate difference between ES and PS.

Thirdly, a theoretical foundation is provided for participants, especially the client, to estimate the potential contractor satisfaction to be gained from the project prior to selecting the project contractor. In previous studies and practices, the client chooses the contractor by comparing bid prices without considering contractor satisfaction. It could be that an unsatisfactory contractor with the lowest tender price is much worse than a satisfactory contractor with a higher priced tender. For this concern, it is necessary to figure out a way to compare contractor satisfaction at tendering stage. Besides graphical way, SEM can also be expressed in regression equation way and many such cases can be found in Keline (2005). Based on direct significant effects showed in Figure 3 and indirect significant effects showed in Table 6, two equations are proposed as follows to calculate changes of ES and PS with participant performance factors' change:

$$\Delta ES = 0.569\Delta DC + 0.314\Delta OC + 0.211\Delta PP - 0.592\Delta RM + (0.367 - 0.311)\Delta OC \text{ and}$$
$$\Delta PS = 0.548\Delta DC + 0.466\Delta EW + 0.342\Delta OC - 0.686\Delta RM + (0.353 - 0.360)\Delta OC.$$

For each equation, the first four components refer to direct effects from participant performance factors and the last component refers to the indirect effects. With these two equations, the client can effectively identify a more satisfied contractor by evaluating and measuring the variation of these performance factors among different bidding contractors with focusing on significant factors. Similarly, the model provides the opportunity for contractors to estimate potential satisfaction and choose a project with a higher likely level of satisfaction, especially in circumstances where many bidding opportunities arise with similar profit expectations. Alternatively, a contractor may decide to bid for projects only where the expected satisfaction exceeds a specific threshold value. Further, as it is reasonable to speculate that better contractors will have a higher satisfaction threshold value, it would then benefit clients to attract good contractors to bid by improving corresponding aspects such as OC, DC, EW and PP.

It should be mentioned, however, that some potential limitations exist for further development. The data are all from a sample of contractors in Malaysia and therefore, although the conclusions are certainly valid for the sample, and probably so for most Malaysian contractors, there applicability outside Malaysia is uncertain, even in other developing countries. Differences in awareness and practices of risk management should be considered particularly when applying similar research in other countries. In addition, although the sample size of 125 used in the study meets the requirements for conducting SEM generally, more data is needed for the development of a complex model and improved model fit. For future research, benefits are envisaged in further exploring the internal dimensions of contractor satisfaction, a more detailed study of the relationship between contractor satisfaction and project success, and the evaluation of satisfaction (for the client) to choose contractors or (for contractors') decision to bid. The results also suggest that future research in the Malaysia context

---

may benefit from a more simplified data collection instrument based on reduced number of hypotheses.

## References

- Al-Kharashi, A., Skitmore, R.M., 2009. Causes of delays in Saudi Arabian public sector construction projects. *Construction Management & Economics* 27 (1), 3-23.
- Al-Tmeemy, S.M.H.M., Abdul-Rahman, H., Harun, Z., 2011. Future criteria for success of building projects in Malaysia. *International Journal of Project Management* 29 (3), 337-348.
- Anvuur, A., Kumaraswamy, M., 2012. Measurement and Antecedents of Cooperation in Construction. *Journal of Construction Engineering and Management* 138 (7), 797-810.
- Assaf, S.A., Al-Hejji, S., 2006. Causes of delay in large construction projects. *International Journal of Project Management* 24 (4), 349-357.
- Atkinson, R., Crawford, L., Ward, S., 2006. Fundamental uncertainties in projects and the scope of project management. *International Journal of Project Management* 24 (8), 687-698.
- Bagozzi, R.P., Yi, Y. 2012. Specification, evaluation, and interpretation of structural equation models, *Journal of the Academy of Marketing Science*, 40, 8-34
- Byrne, B.M., ed. 2010. *Structural equation modeling with AMOS: basic concepts, applications, and programming*. New York: Routledge.
- Chan, A., Scott, D., and Lam, E. 2002. Framework of Success Criteria for Design/Build Projects. *Journal of Management in Engineering* 18 (3), 120–128.
- Cheng, J., Proverbs, D.G., Oduoza, C.F., 2006. The satisfaction levels of UK construction clients based on the performance of consultants: Results of a case study. *Engineering, Construction and Architectural Management* 13 (6), 567-583.
- Cho, K., Hong, T., Hyun, C., 2009. Effect of project characteristics on project performance in construction projects based on structural equation model. *Expert Systems with Applications* 36 (7), 10461-10470.
- CIDB., 2006. *Construction Industry Master Plan 2006-2015 (CIMP 2006-2015)*, Construction Industry Development Board (CIDB) Malaysia.
- del Bosque Rodríguez, I.R., Agudo, J.C., San Martín Gutiérrez, H., 2006. Determinants of economic and social satisfaction in manufacturer–distributor relationships. *Industrial Marketing Management* 35 (6), 666-675.
- Doloi, H., Iyer, K.C., Sawhney, A., 2011. Structural equation model for assessing impacts of contractor's performance on project success. *International Journal of Project Management* 29 (6), 687-695.
- Doloi, H., Sawhney, A., Iyer, K.C., Rentala, S., 2012. Analysing factors affecting delays in Indian construction projects. *International Journal of Project Management* 30 (4), 479-489.
- Gorsuch, R. L. 1983. *Factor Analysis*, Lawrence Erlbaum, Hillsdale, New Jersey



- 
- Harmon, K.M.J., 2003. Conflicts between owner and contractors: proposed intervention process. *Journal of Management in Engineering* 19 (3), 121-125.
- Islam, M. M., Faniran, O. O. 2005. Structural equation model of project planning effectiveness. *Construction Management and Economics*, 23 (2), 215-223.
- Jyh-Bin, Y., Shen-Fen, O., 2008. Using structural equation modeling to analyze relationships among key causes of delay in construction. *Canadian Journal of Civil Engineering* 35 (4), 321-332.
- Kärnä, S., Sorvala, V.M., Junnonen, J.M., 2009. Classifying and clustering construction projects by customer satisfaction. *Facilities* 27 (9/10), 387-398.
- Keline, R.B., ed. 2005. Principles and practice of structural equation modeling. New York: The Guilford Press Inc.
- Lehtiranta, L., Kärnä, S., Junnonen, J.-M., Julin, P. 2012. The role of multi-firm satisfaction in construction project success. *Construction Management and Economics* 30 (6), 463-475.
- Leung, M.Y., Ng, S.T., Cheung, S.O., 2004. Measuring construction project participant satisfaction. *Construction Management and Economics* 22 (3), 319-331.
- Ling, F.Y.Y., Chong, C.L.K., 2005. Design-and-build contractors' service quality in public projects in Singapore. *Building and Environment* 40 (6), 815-823.
- Ling, F.Y.Y., Low, S.P., Wang, S.Q., Egbelakin, T., 2008. Models for predicting project performance in China using project management practices adopted by foreign AEC firms. *Journal of Construction Engineering and Management* 134 (12), 983.
- Liu, A.M.M., Leung, M., 2002. Developing a soft value management model. *International Journal of Project Management* 20 (5), 341-349.
- Love, P.E.D., Holt, G.D., 2000. Construction business performance measurement: the SPM alternative. *Business Process Management Journal* 6 (5), 408-416.
- Maloney, W.F., 2002. Construction product/service and customer satisfaction. *Journal of Construction Engineering and Management* 128 (6), 522-529.
- Masrom, M.A.N., 2011. Developing a predictive contractor satisfaction model (COSMO) for construction projects, unpublished PhD thesis, Queensland University of Technology, Brisbane.
- Mbachu, J., Nkado, R., 2006. Conceptual framework for assessment of client needs and satisfaction in the building development process. *Construction Management and Economics* 24 (1), 31-44.
- Nerkar, A.A., McGrath, R.G., MacMillan, I.C., 1996. Three facets of satisfaction and their influence on the performance of innovation teams. *Journal of Business Venturing* 11 (3), 167-188.
- Odeh, A.M., Battaineh, H.T., 2002. Causes of construction delay: traditional contracts. *International Journal of Project Management* 20 (1), 67-73.
- Oke, A. E., Ogunsami, D. R., Ogunlana, S., 2012. Establishing a common ground for the use of structural equation modelling for construction related research studies. *Australasian Journal of Construction Economics and Building*, 12 (3), 89-94.

- 
- Ong, T.F., Musa, G., 2012. Examining the influences of experience, personality and attitude on SCUBA divers' underwater behaviour: A structural equation model. *Tourism Management* 33 (6), 1521-1534.
- Park, S.H., 2009. Whole life performance assessment: critical success factors. *Journal of Construction Engineering and Management* 135 (11), 1146-1161.
- Paul, W.L., Taylor, P.A., 2008. A comparison of occupant comfort and satisfaction between a green building and a conventional building. *Building and Environment* 43 (11), 1858-1870.
- Sambasivan, M., Soon, Y.W., 2007. Causes and effects of delays in Malaysian construction industry. *International Journal of Project Management* 25 (5), 517-526.
- Siang, L.C., Ali, A.S., 2012. Implementation of Risk Management in the Malaysian Construction Industry. *Journal of Surveying, Construction & Property*, 3, 1-15.
- Soetanto, R., Proverbs, D.G., 2002. Modelling the satisfaction of contractors: the impact of client performance. *Engineering Construction and Architectural Management* 9 (5/6), 453-465.
- Sobel, Michael E. 1982. Asymptotic Confidence Intervals for Indirect Effects in Structural Equation Models. *Sociological Methodology* 13, 290–312.
- Toor, S.R., Ogunlana, S.O., 2010. Beyond the 'iron triangle': Stakeholder perception of key performance indicators (KPIs) for large-scale public sector development projects. *International Journal of Project Management* 28 (3), 228-236.
- Torbica, Z.M., Stroh, R.C., 2001. Customer satisfaction in home building. *Journal of Construction Engineering and Management* 127 (1), 82-86.
- Wanous, J.P., Lawler, E.E., 1972. Measurement and meaning of job satisfaction. *Journal of Applied Psychology* 56 (2), 95-105.
- Washington, S., Karlaftis, M.G., Mannering, F.L., 2011. *Statistical and econometric methods for transportation data analysis*. Boca Raton: Chapman & Hall/CRC.
- Wirtz, J. 2001. Improving the measurement of customer satisfaction: a test of three methods to reduce halo. *Managing Service Quality* 11 (2), 99-112.
- Yang, J.-B., Peng, S.-C., 2008. Development of a customer satisfaction evaluation model for construction project management. *Building and Environment* 43 (4), 458-468.
- Ye, K.H., Xiong, B., 2011. Corporate social performance of construction contractors in China: Evidences from major firms. *Proceedings of the 16th International Symposium on Advancement of Construction Management and Real Estate*, Hong Kong Polytechnic Univ, 125-130.
- Yong, Y.C., Mustafa, N.E., 2012. Analysis of factors critical to construction project success in Malaysia. *Engineering, Construction and Architectural Management* 19 (5), 543 - 556.

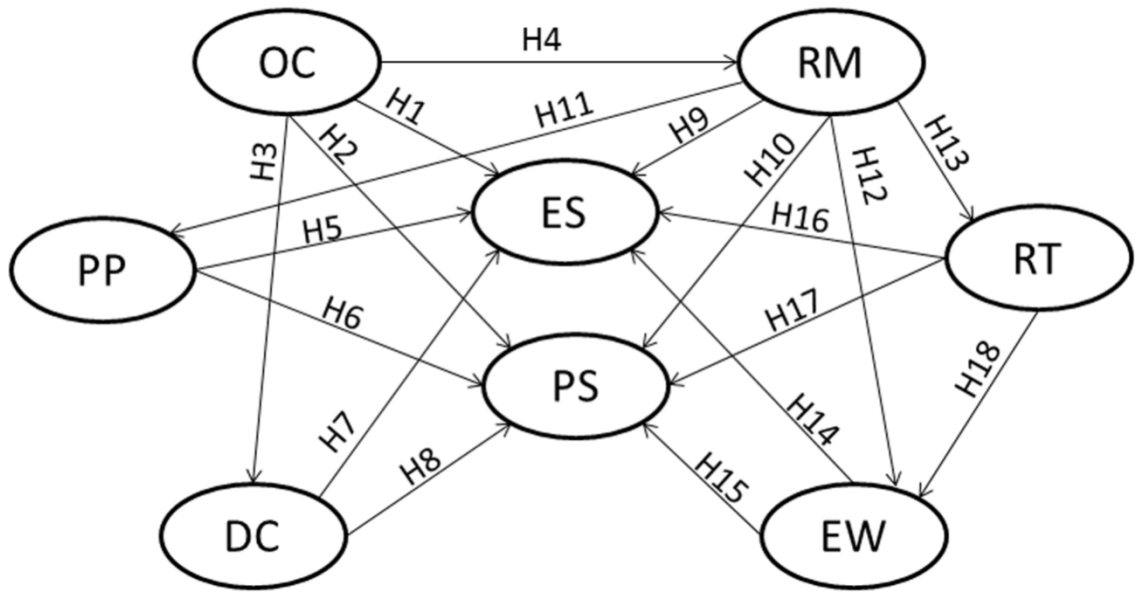
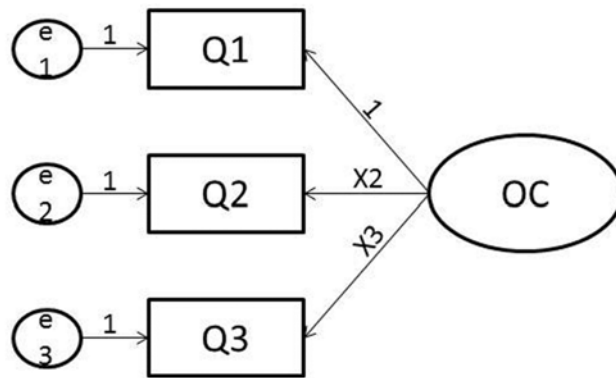

Figure 1: Structural component



*Figure 2: Measurement component*

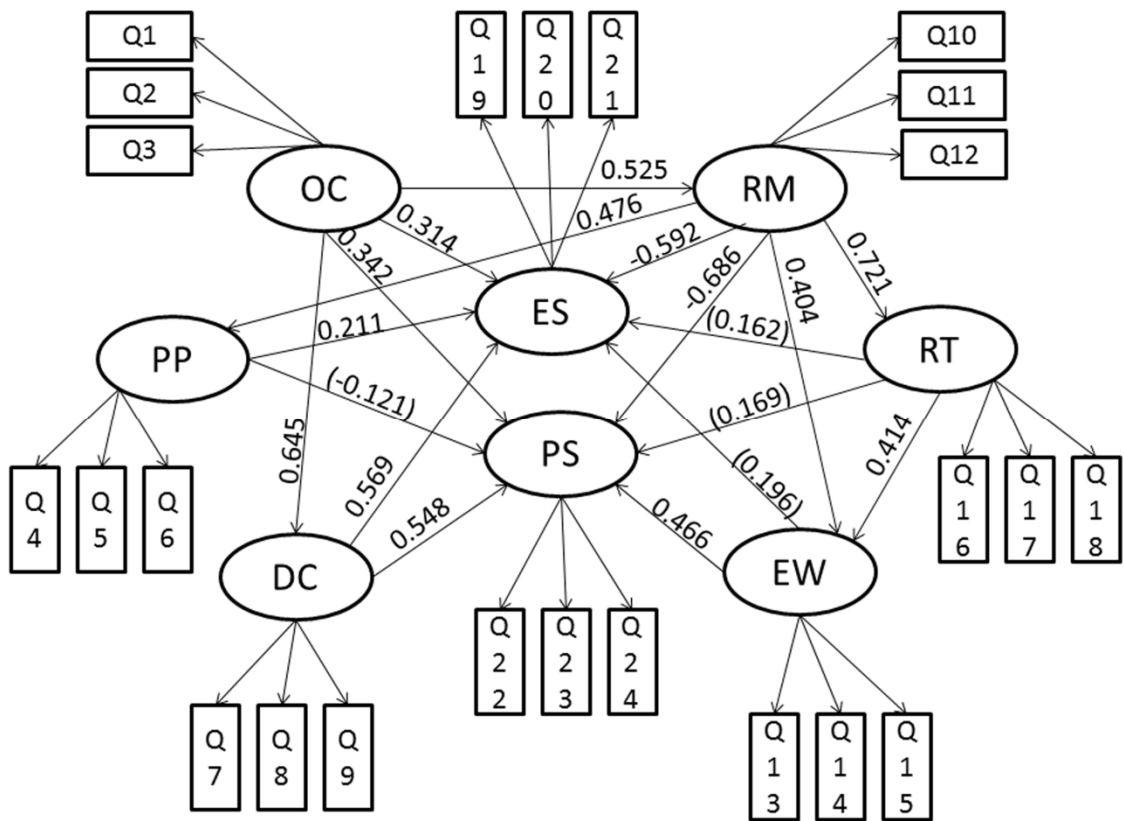

Figure 3: Final SEM model results

*Table 1: Constructs and measurement of SEM*

<b>Latent variables</b>	<b>Abbr.</b>	<b>No.</b>	<b>Items</b>
<i>Performance variables: Which performance level would you rate? (1=very bad, 5=very good)</i>			
Client's clarity of objectives	OC	Q1 Q2 Q3	Quality of project brief (e.g. needs and requirements) Completeness of project brief Certainty of project brief
Client's promptness of payments	PP	Q4 Q5 Q6	Ease of final account settlement Speed of final account settlement Promptness of progress payment made by the client
Designer carefulness	DC	Q7 Q8 Q9	Design constructability Comprehensiveness of design Flexibility of design to accommodate changes
Construction risk management	RM	Q10 Q11 Q12	Efficiency of risk control (e.g. identification, evaluation) Effectiveness of conflict management Appropriateness of sharing risks with other participants
Effectiveness of other project participants	EW	Q13 Q14 Q15	Productivity of project manpower Efficiency of subcontractor to undertake their work Supplier effectiveness in material supply
Respect and trust among project participants	RT	Q16 Q17 Q18	Participants' respect and friendliness during the project Trust between participants and project team Understanding between participants and project team
<i>Satisfaction variables: Which satisfaction level would you rate? (1=very dissatisfied, 5=very satisfied)</i>			
Economic-related satisfaction	ES	Q19 Q20 Q21	Project cost management performance (actual vs budget) Project profitability Potential business development in future
Production-related satisfaction	PS	Q22 Q23 Q24	Schedule performance (actual vs budget) Construction product quality performance Safety of worksite

---

*Table 2: Details of respondents*

<b>Respondent's information</b>	<b>Groups</b>	<b>Frequency</b>	<b>Percent</b>	<b>Cumulative Percent</b>
Education level	Certificate	11	8.8	8.8
	Diploma	39	31.2	40
	Bachelor degree	69	55.2	95.2
	Master degree	6	4.8	100
	PHD	0	0	100
Education background	Architecture	9	7.2	7.2
	Project management	32	25.6	32.8
	Quantity surveying	31	24.8	57.6
	Civil engineering	40	32	89.6
	other	13	10.4	100
Management position	Top level	61	48.8	48.8
	Middle level	57	45.6	94.4
	Low level	7	5.6	100
Experience	1-5 years	22	17.6	17.6
	6-10 years	52	41.6	59.2
	11-15 years	26	20.8	80
	16+ years	25	20	100

---

---

*Table 3: Reliability test of the questionnaire responses*

<b>Variables</b>	<b>All 24</b>	<b>Q1-3</b>	<b>Q4-6</b>	<b>Q7-9</b>	<b>Q10-12</b>	<b>Q13-15</b>	<b>Q16-18</b>	<b>Q19-21</b>	<b>Q22-24</b>
Chronbach's Alpha value	0.922	0.873	0.863	0.839	0.870	0.793	0.861	0.814	0.758



Table 4: Standardized regression weights and SMCs

Item	Standardized regression weights								SMC
	OC	PP	DC	RM	EW	RT	ES	PS	
Q1	0.82 <sup>a</sup>								0.67
Q2	0.91								0.82
Q3	0.81								0.65
Q4		0.93 <sup>a</sup>							0.86
Q5		0.91							0.83
Q6		0.65							0.42
Q7			0.79						0.63
Q8			0.88						0.78
Q9			0.74 <sup>a</sup>						0.55
Q10				0.81 <sup>a</sup>					0.65
Q11				0.87					0.76
Q12				0.81					0.66
Q13					0.69 <sup>a</sup>				0.47
Q14					0.87				0.75
Q15					0.70				0.48
Q16						0.74			0.54
Q17						0.91			0.82
Q18						0.84 <sup>a</sup>			0.71
Q19							0.78 <sup>a</sup>		0.61
Q20							0.77		0.60
Q21							0.76		0.58
Q22								0.73	0.53
Q23								0.71	0.51
Q24								0.72 <sup>a</sup>	0.52

All results are from analyses that included company size as a control variable. All factors without superscript 'a' are significant at  $p < 0.001$ ; Factors with superscript 'a' are fixed to 1.00 before estimation.

---

Table 5: Results of goodness of fit (Adapted from Ong and Musa (2012))

<b>Goodness of fit measure</b>	<b>Index</b>	<b>Criteria</b>
$\chi^2/\text{df}$	1.325	<5.0
<i>Absolute fit</i>		
RMSEA	0.051	<0.08
SRMR	0.045	<0.05
<i>Incremental fit</i>		
CFI	0.957	>0.9
TLI	0.945	>0.9
<i>Parsimonious fit</i>		
PNFI	0.665	>0.5
PGFI	0.610	>0.5

---

*Table 6: P values and indirect effects (Sobel test)*

<b>Paths</b>	<b>Probability</b>	<b>Indirect effect</b>
RT ->EW->PS	0.068	0.193
RM->EW->PS	0.083	0.188
RM->PP ->ES	0.058	0.100
OC->RM->ES	0.022	-0.311*
OC->RM->PS	0.012	-0.360*
OC->DC->ES	0.002	0.367*
OC->DC->PS	0.004	0.353*

\* indirect effects when  $p < 0.05$