

## **HIGH TEMPERATURE WIRELESS COMMUNICATION AND ELECTRONICS FOR HARSH ENVIRONMENT APPLICATIONS**

**G. W. Hunter, P. G. Neudeck, G. M. Beheim, and G. E. Ponchak**

NASA Glenn Research Center at Lewis Field, 21000 Brookpark Road, Cleveland, OH 44135, USA,

**L.-Y. Chen**

OAI

22800 Cedar Point Road, Cleveland, OH 44142, USA

In order for future aerospace propulsion systems to meet the increasing requirements for decreased maintenance, improved capability, and increased safety, the inclusion of intelligence into the propulsion system design and operation becomes necessary. These propulsion systems will have to incorporate technology that will monitor propulsion component conditions, analyze the incoming data, and modify operating parameters to optimize propulsion system operations. This implies the development of sensors, actuators, and electronics, with associated packaging, that will be able to operate under the harsh environments present in an engine. However, given the harsh environments inherent in propulsion systems, the development of engine-compatible electronics and sensors is not straightforward.

The ability of a sensor system to operate in a given environment often depends as much on the technologies supporting the sensor element as the element itself. If the supporting technology cannot handle the application, then no matter how good the sensor is itself, the sensor system will fail. An example is high temperature environments where supporting technologies are often not capable of operation in engine conditions. Further, for every sensor going into an engine environment, i.e., for every new piece of hardware that improves the in-situ intelligence of the components, communication wires almost always must follow. The communication wires may be within or between parts, or from the engine to the controller. As more hardware is added, more wires, weight, complexity, and potential for unreliability is also introduced. Thus, wireless communication combined with in-situ processing of data would significantly improve the ability to include sensors into high temperature systems and thus lead toward more intelligent engine systems.

NASA Glenn Research Center (GRC) is presently leading the development of electronics, communication systems, and sensors capable of prolonged stable operation in harsh 500°C environments. This has included world record operation of SiC-based transistor technology (including packaging) that has demonstrated continuous electrical operation at 500°C for over 2000 hours. Based on SiC electronics, development of high temperature wireless communication has been on-going. This work has concentrated on maturing the SiC electronic devices for communication purposes as well as the passive components such as resistors and capacitors needed to enable a high temperature wireless system. The objective is to eliminate wires associated with high temperature sensors which add weight to a vehicle and can be a cause of sensor unreliability.

This paper discusses the development of SiC based electronics and wireless communications technology for harsh environment applications such as propulsion health management systems and in Venus missions. A brief overview of the future directions in sensor technology is given including maturing of near-room temperature “Lick and Stick” leak sensor technology for possible implementation in the Crew Launch Vehicle program. Then an overview of high temperature electronics and the development of high temperature communication systems is presented. The maturity of related technologies such as sensor and packaging will also be discussed. It is concluded that a significant component of efforts to improve the intelligence of harsh environment operating systems is the development and implementation of high temperature wireless technology.

# **High Temperature Wireless Communication And Electronics For Harsh Environment Applications**

**G. W. Hunter, P. G. Neudeck, G. M. Beheim, and G. E.  
Ponchak**

**NASA Glenn Research Center  
Cleveland, OH**

**L.Y. Chen  
OAI  
Cleveland, OH**

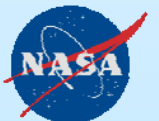

# OUTLINE

- **INTRODUCTION**
- **EXPLORATION ISHM/IVHM**
- **AERONAUTICS IVHM**
- **HIGH TEMPERATURE WIRELESS AND ELECTRONICS**
- **NASA APPLICATIONS**
- **SUMMARY AND CONCLUSIONS**

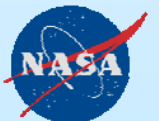

# EXPLORATION ISHM/IVHM AND SENSOR MOTIVATION

- **FUTURE EXPLORATION MISSIONS WILL REQUIRE SIGNIFICANTLY IMPROVED INTEGRATED SYSTEM/VEHICLE HEALTH MANAGEMENT (ISHM/IVHM) THROUGHOUT THE VEHICLE**
  - **LIMITED GROUND SUPPORT**
  - **CONSTRAINED IN TIME, RESOURCES, AND CAPABILITIES FROM PERFORMING EXTENSIVE SYSTEM MAINTENANCE, REPAIR, OR REPLACEMENT.**
  - **IMPROVED SYSTEM SAFETY, RELIABILITY, AND EFFICIENCY.**
  - **IDENTIFY PROBLEMS BEFORE THEY CAUSE HARM**
- **VEHICLE SYSTEMS THAT REQUIRE INTENSE HUMAN INTERVENTION OR MONITORING ARE IMPEDIMENTS TO REALIZATION OF THE EXPLORATION VISION.**
- **INCLUSION OF AUTOMATED VEHICLE INTELLIGENCE INTO THE SYSTEM DESIGN AND OPERATION IS NECESSARY**
- **ENABLE INTERNAL SYSTEMS TO MONITOR COMPONENT CONDITIONS, ANALYZE THE INCOMING DATA, AND MODIFY OPERATING PARAMETERS TO OPTIMIZE SYSTEM OPERATIONS TO ACHIEVE IMPROVED PERFORMANCE AND RELIABILITY.**
- **IF PROBLEMS DO OCCUR, SOME AUTONOMOUS PROGNOSIS/DIAGNOSIS, FAULT ISOLATION, AND REMEDIATION IS NECESSARY I.E. THE VEHICLE WILL NEED INTEGRATED INTELLIGENCE AND ADVANCED ISHM SYSTEMS.**

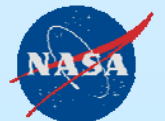

# EXPLORATION ISHM/IVHM SENSOR SYSTEMS

- **HIGH-QUALITY DATA PROVIDED BY SENSOR SYSTEMS IS A FOUNDATION OF ISHM**
- **PRESENT SENSOR TECHNOLOGY DOES NOT MEET NASA EXPLORATION NEEDS. NASA NEEDS IN SENSORS ARE SPECIALIZED AND REVOLVE AROUND ITS UNIQUE MISSION. OFF-THE-SHELF TECHNOLOGY IS OFTEN NOT APPLICABLE**
- **IF ISHM IS GOING TO BE EFFECTIVE, THEN IT SHOULD BE APPLIED WHERE IT IS NEEDED, NOT JUST WHERE IT IS CONVENIENT.**
  - **FOR EXAMPLE, LIMITED ON-BOARD HARSH ENVIRONMENTS SENSORS LEAVING SIGNIFICANT AREAS OF THE PROPULSION SYSTEM UNMONITORED.**
- **WHILE NASA MIGHT LEVERAGE SENSOR TECHNOLOGY BEING DEVELOPED ELSEWHERE, NASA UNIQUE PROBLEMS REQUIRE SPECIALIZED SOLUTIONS.**

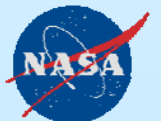

# ISHM SENSOR SYSTEM DEVELOPMENT

- DO NOT ASSUME IT WILL JUST BE THERE WHEN NEEDED
- SENSORS AND ISHM INCLUSION OFTEN PROBLMATIC IN VEHICLE SYSTEMS
  - LEGACY SYSTEMS
  - CUSTOMER ACCEPTANCE
  - LONG-TERM VS SHORT TERM CONSIDERATIONS
- MICROSYSTEM APPROACHES MAY PROVIDE NEW CAPABILITIES
- BASED ON INTELLIGENCE RESIDING WITHIN EACH SMART SENSOR CONTRIBUTING TO THE INTELLIGENCE OF THE COMPLETE SYSTEM.

## Microsystem Block Diagram

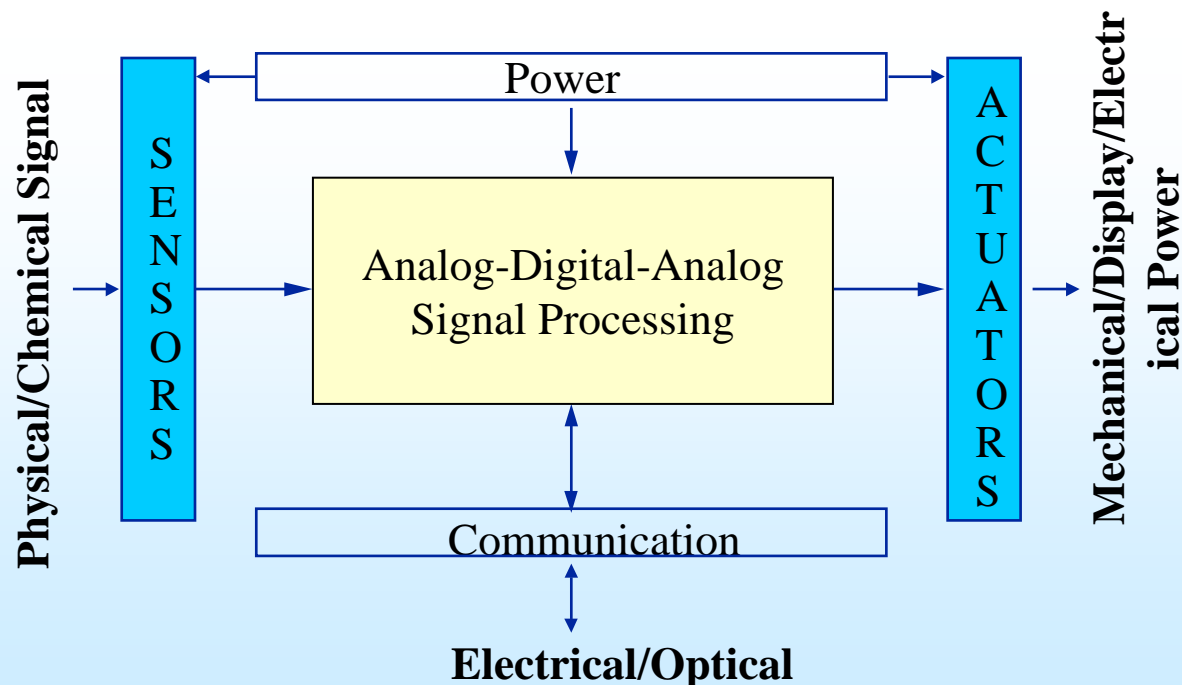

# POSSIBLE STEPS TO REACH INTELLIGENT SYSTEMS

## •“LICK AND STICK” TECHNOLOGY (EASE OF APPLICATION)

- Micro and nano fabrication to enable multipoint inclusion of sensors, actuators, electronics, and communication throughout the vehicle without significantly increasing size, weight, and power consumption. Multifunctional, adaptable technology included.

## •RELIABILITY:

- Users must be able to believe the data reported by these systems and have trust in the ability of the system to respond to changing situations e.g. decreasing sensors should be viewed as decreasing the available information flow about a vehicle. Inclusion of intelligence more likely to occur if it can be trusted.

## •REDUNDANCY AND CROSS-CORRELATION:

- If the systems are easy to install, reliable, and not increase weight/complexity, the application of a large number of them is not problematic. This allow redundant systems, e.g. sensors, spread throughout the vehicle. These systems will give full-field coverage of the engine parameters but also allow cross-correlation between the systems to improve reliability of sensor data and the vehicle system information.

## •ORTHOGONALITY:

- Systems should each provide a different piece of information on the vehicle system. Thus, the mixture of different techniques to “see, feel, smell, hear” as well as move can combine to give complete information on the vehicle system as well as the capability to respond to the environment.

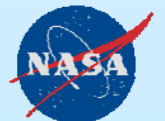

# “LICK AND STICK” LEAK SENSOR SYSTEM

- FUEL/OXYGEN LEAK DETECTION WITH POWER, SIGNAL CONDITIONING, TELEMETRY ALL IN THE SURFACE AREA OF A POSTAGE STAMP
- GOAL: DETECT EXPLOSIVE CONCENTRATIONS FOR MULTIPLE VEHICLES, A WIDE RANGE OF FUELS WITH “LICK AND STICK” SYSTEMS
- MOVING TOWARD CLV APPLICATIONS
- SYSTEM CALIBRATION AND SELF-CHECK ARE MAJOR ISSUES (ON-BOARD INTELLIGENCE)

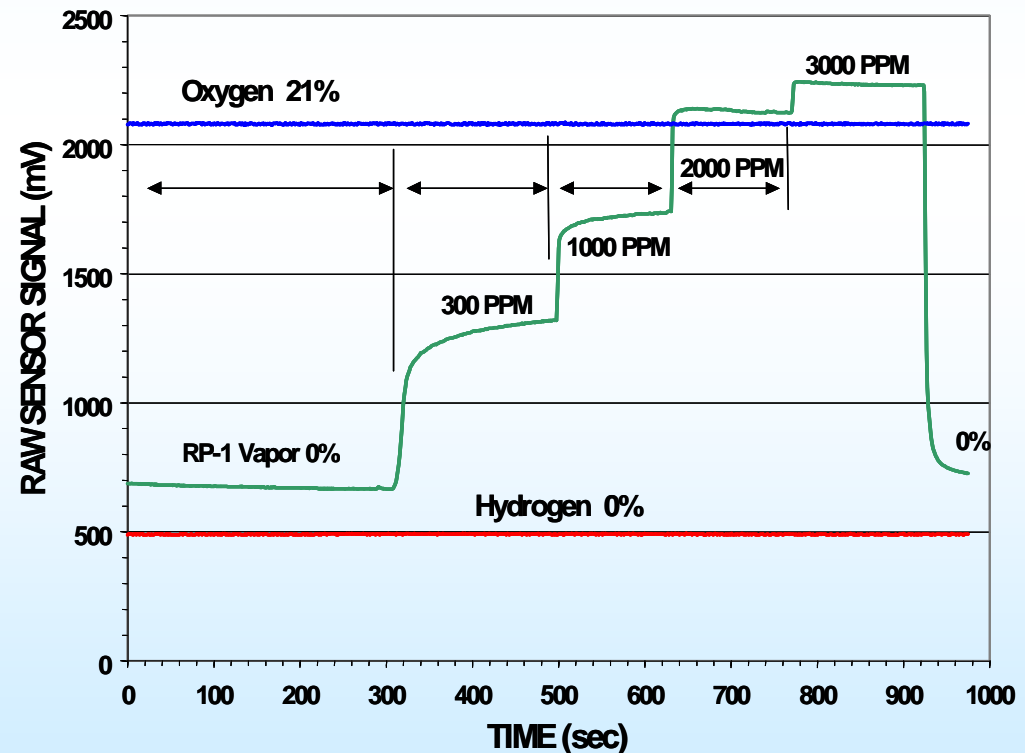
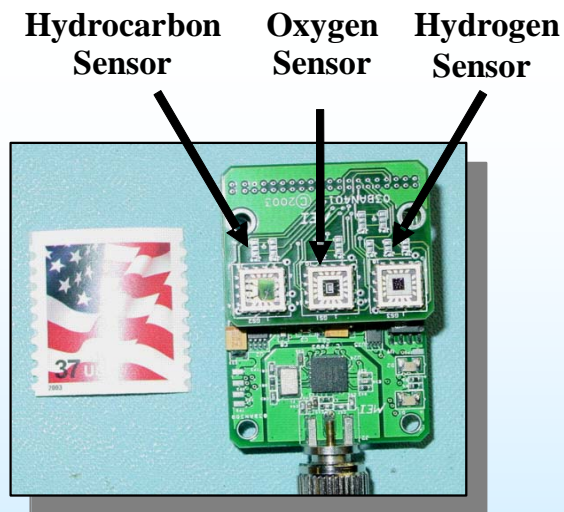



# AERONAUTICS IVHM PROGRAM

## AVIATION SAFETY PROGRAM

### Integrated Continuous Onboard Vehicle Health State Assessment and Management

Airframe



Propulsion



Aircraft Systems



### Onboard Environmental Hazard Detection and Effects Mitigation

Icing & Fuel Safety



Lightning and EMI/EMC



Ionizing Radiation

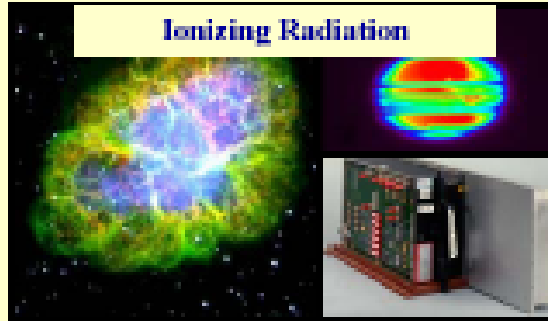

### IVHM System Technologies

Architectures and Databases

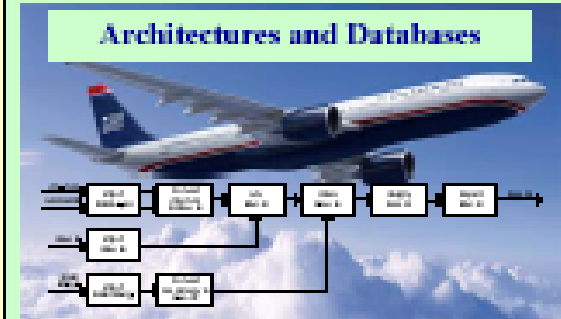

Verification and Validation



Integration & Assessment



# *Propulsion Health Management*

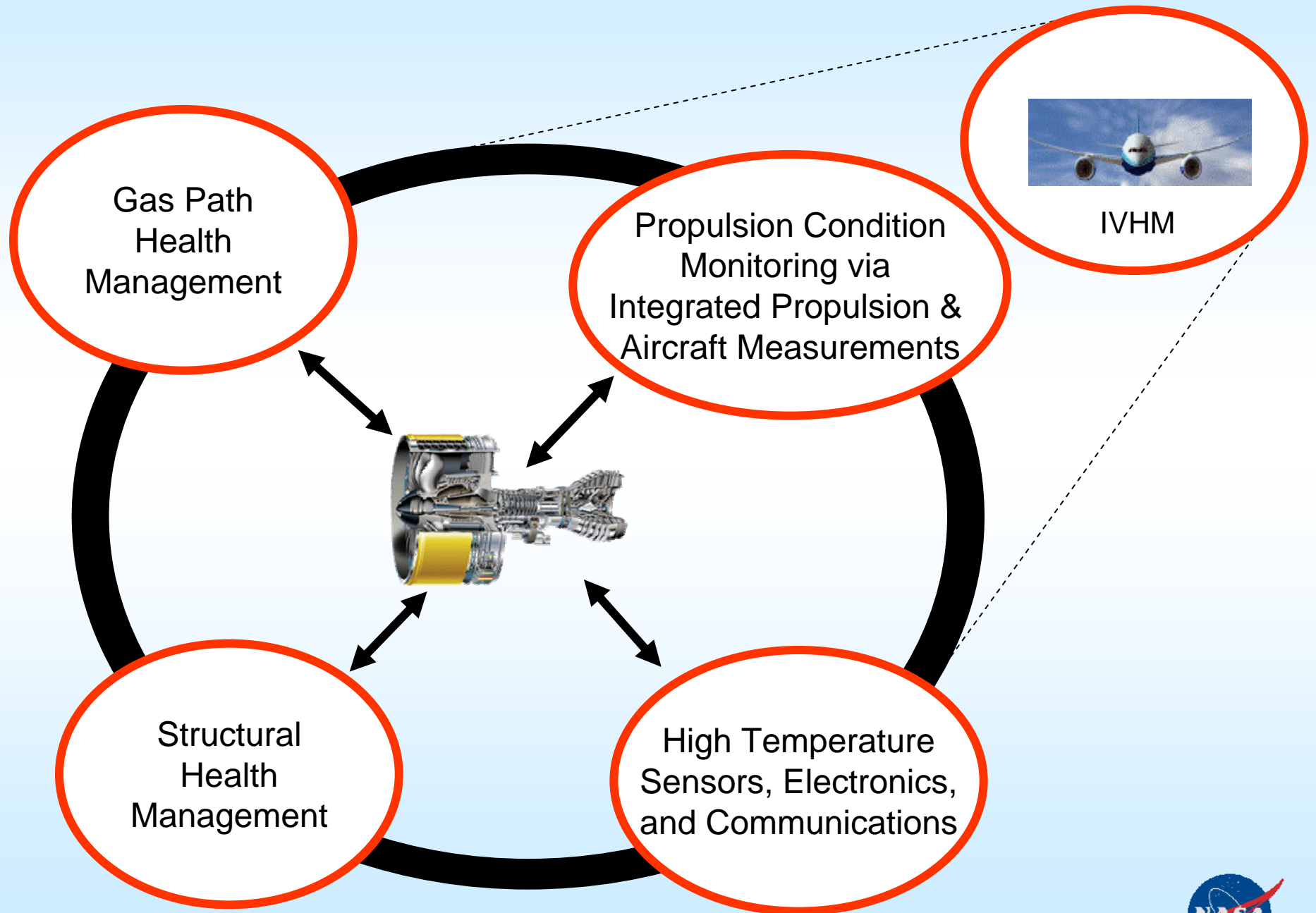

# Aeronautics IVHM Propulsion: High Temperature Sensors, Electronics, And Communications

## Enable New Capabilities ...

- Propulsion Structural Health Monitoring
- High-temperature Pressure Sensors and
- High-temperature Wireless Communications And Energy Harvesting Technologies

## Technical Approach:

- Propulsion structural health monitoring including smart accelerometers, and optical strain and blade tip-timing sensors.
- Pressure sensors for incorporation into gas-path trending and fault diagnostic models to infer turbine health.
- Integration of sensor technology with high temperature wireless communications and energy harvesting to enable a smart systems operable at high temperatures.
  - High-temperature wireless communications based on SiC electronics and rugged RF passive components
  - Energy harvesting systems focusing thermo-electric and photo-voltaic materials for generation of power for remote sensors.

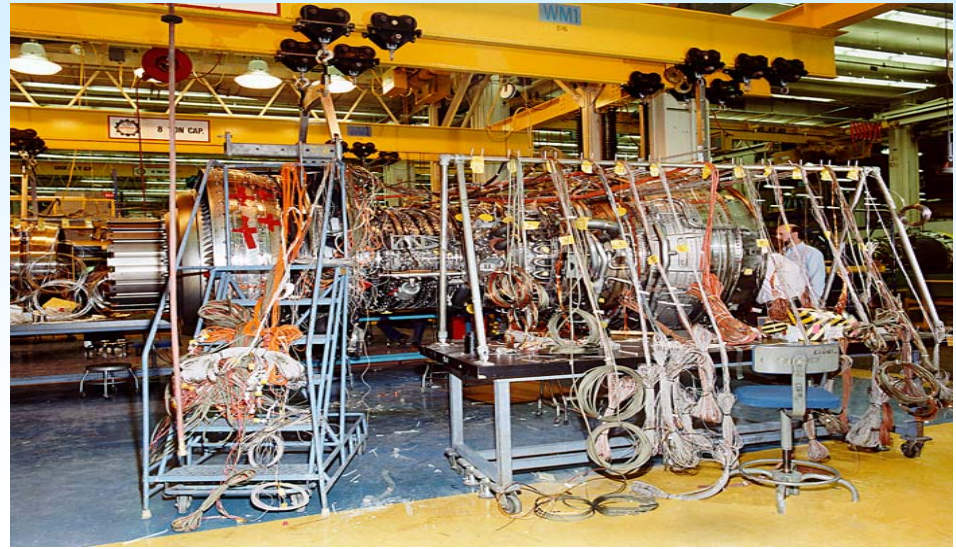

**Significant wiring exists with present sensor systems**

**Allow Sensor Implementation by Eliminating Wires**

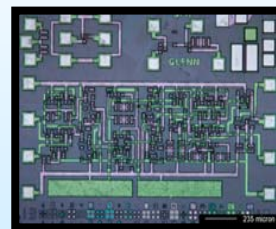

World Record High Temperature Electronics Device Operation

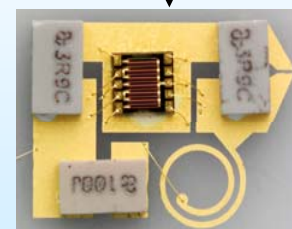

High Temperature RF Components

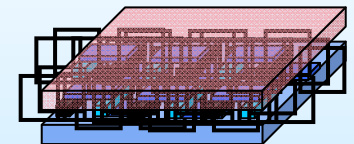

Energy Harvesting Thin Film Thermoelectrics

# SENSORS AND ELECTRONICS TECHNOLOGY BRANCH

## SCOPE OF WORK

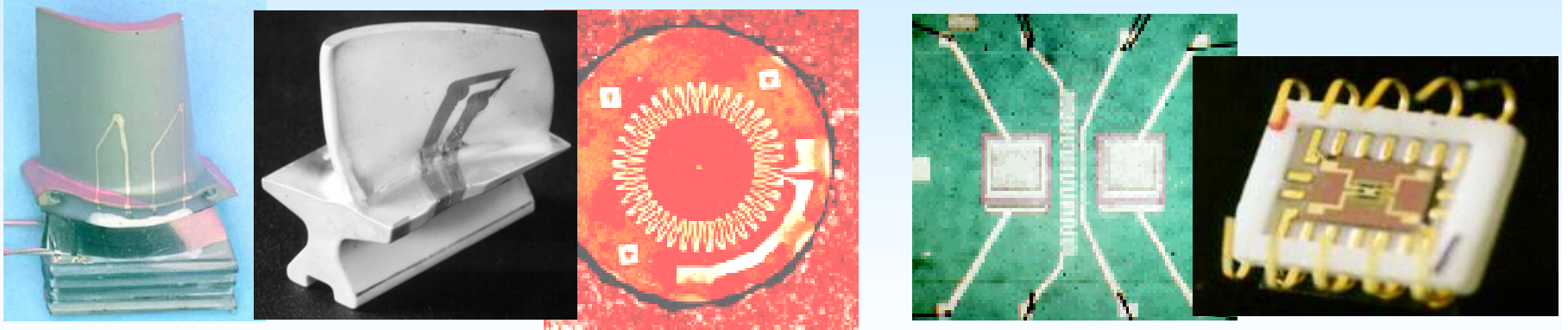

**PHYSICAL SENSORS (T, Strain, Heat Flux)**

**CHEMICAL SENSORS**

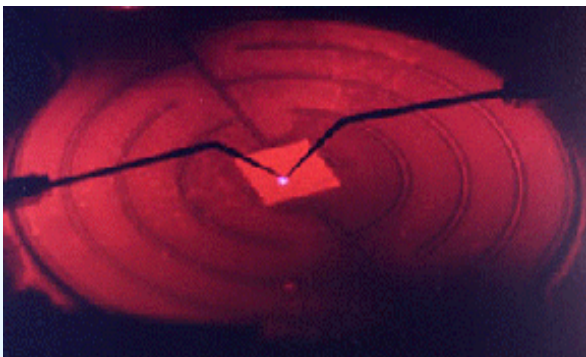

**SILICON CARBIDE HIGH  
TEMP ELECTRONICS**

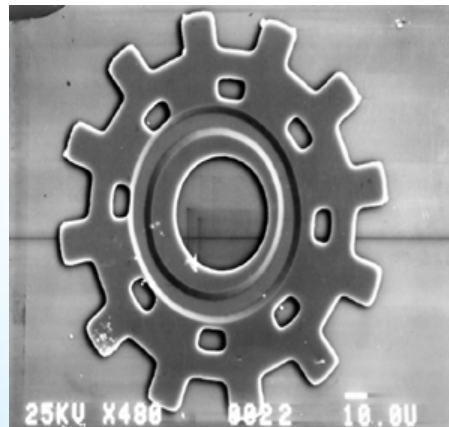

**MICRO-ELECTRO-  
MECHANICAL SYSTEMS**

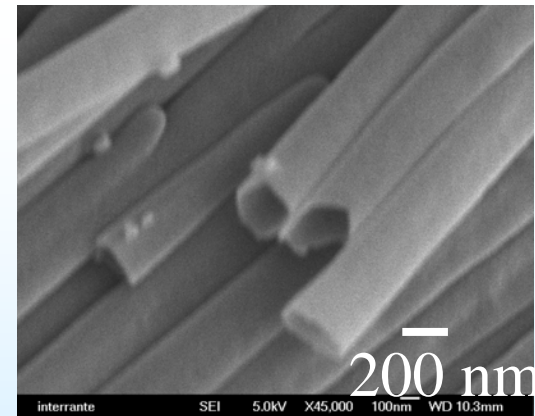

**NANOTECHNOLOGY**



# NASA GRC: CUTTING EDGE DEVELOPMENT HARSH ENVIRONMENT SENSORS AND ELECTRONICS



# HARSH ENVIRONMENT ELECTRONICS AND SENSORS APPLICATIONS

- **NEEDS:**

- OPERATION IN HARSH ENVIRONMENTS
- RANGE OF PHYSICAL AND CHEMICAL MEASUREMENTS
- INCREASE DURABILITY, DECREASE THERMAL SHIELDING, IMPROVE IN-SITU OPERATION

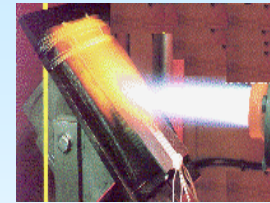

1998 R&D 100 Award

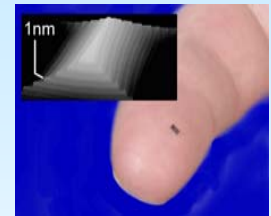

2004 R&D 100 Award

- **RESPONSE: UNIQUE RANGE OF HARSH ENVIRONMENT TECHNOLOGY AND CAPABILITIES**

- STANDARD 500C OPERATION BY MULTIPLE SYSTEMS
- TEMPERATURE, PRESSURE, CHEMICAL SPECIES, WIND AVAILABLE
- HIGH TEMPERATURE ELECTRONICS TO MAKE SMART SYSTEMS

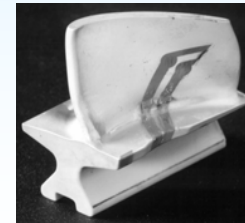

1995 R&D 100 Award



1991 R&D 100 Award

- **ALL-IN-ONE SHOP FOR HARSH ENVIRONMENT SYSTEM APPLICATIONS**

- **ENABLE EXPANDED MISSION PARAMETERS/IN-SITU MEASUREMENTS**

## Range of Physical and Chemical Sensors for Harsh Environments



## Harsh Environment Packaging (2000 hours at 500C)

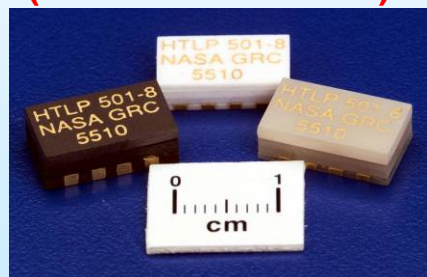

## High Temperature Signal Processing and Wireless



## Long Term: High Temperature "Lick and Stick" Systems

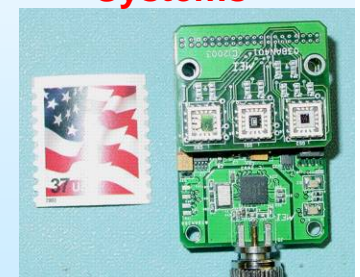

# 6H-SiC JFET NOR Gate

3 x 300  $\mu\text{m}$  JFET's

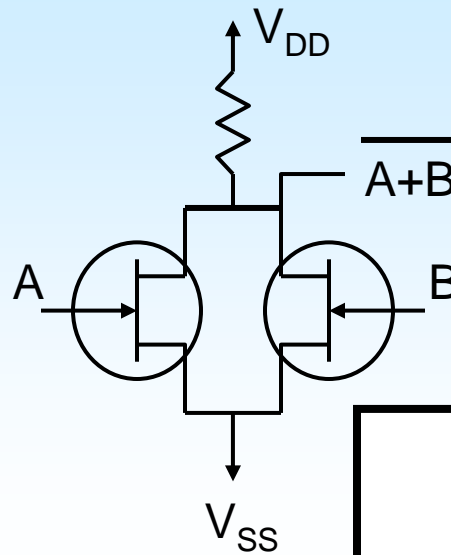
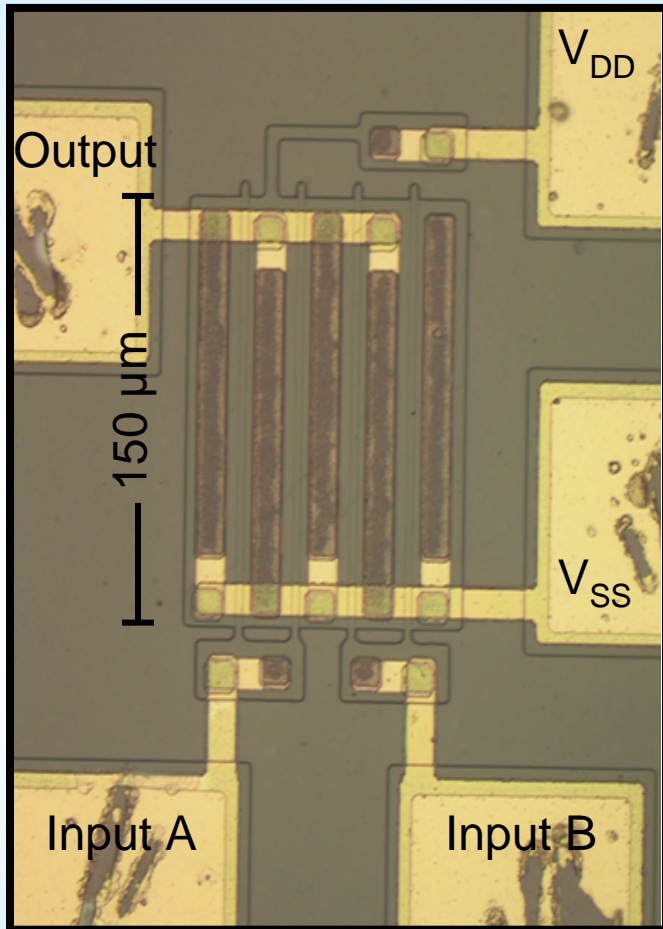

**T = 600 °C**

$V_{DD} = 3.5 \text{ V}$

$V_{SS} = 0 \text{ V}$

$V_{\text{substrate}} = -1.8 \text{ V}$ .

A	B	$\overline{A+B}$
0	0	1
0	1	0
1	0	0
1	1	0

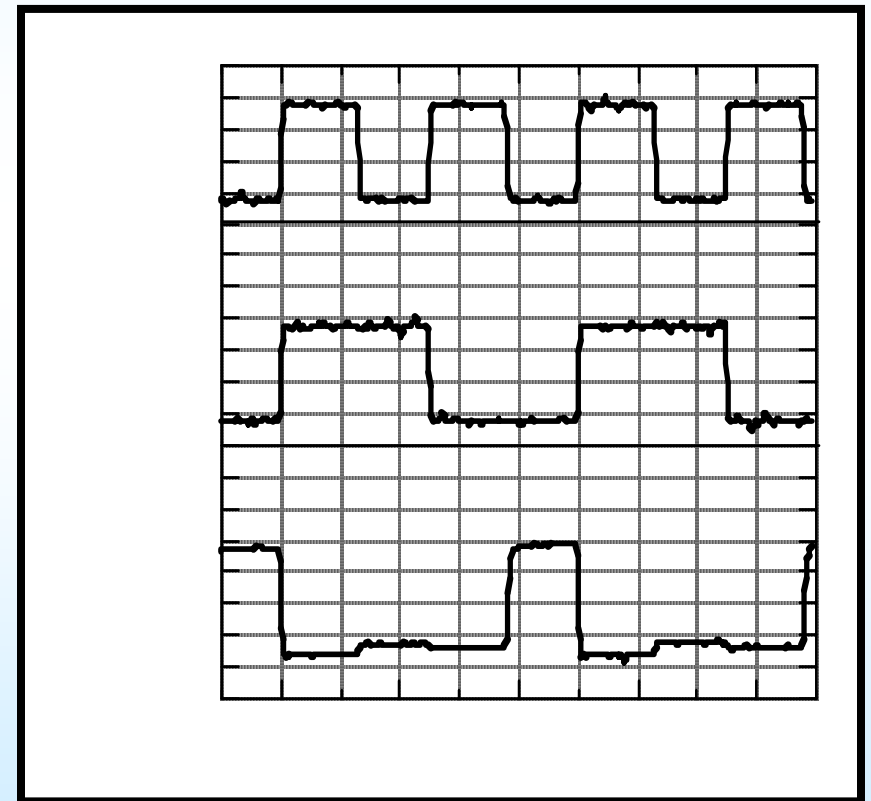

Unpackaged device tested for approx. 1 hour on prober with hot-chuck in 1997.



# NASA/GMI 6H-SiC JFET Amplifier Circuit

(Under Construction)

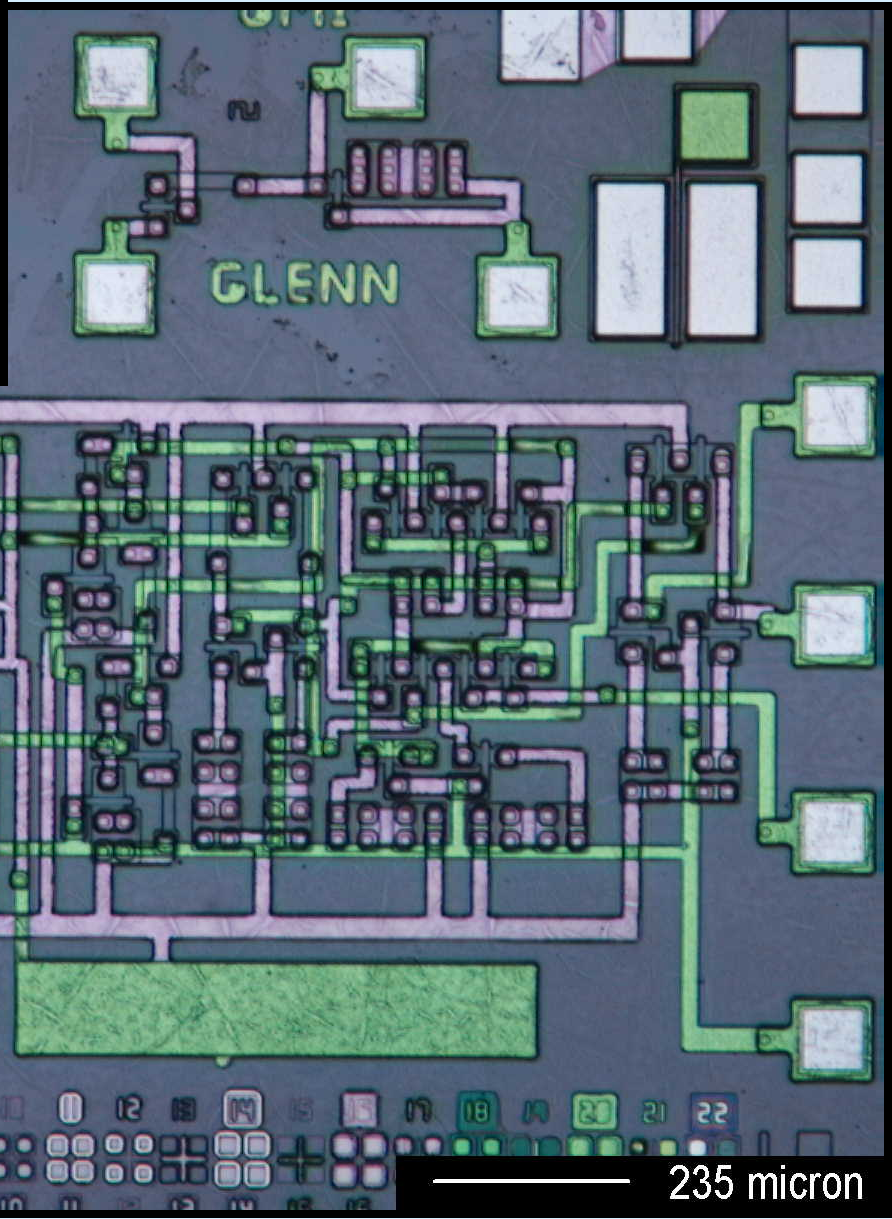
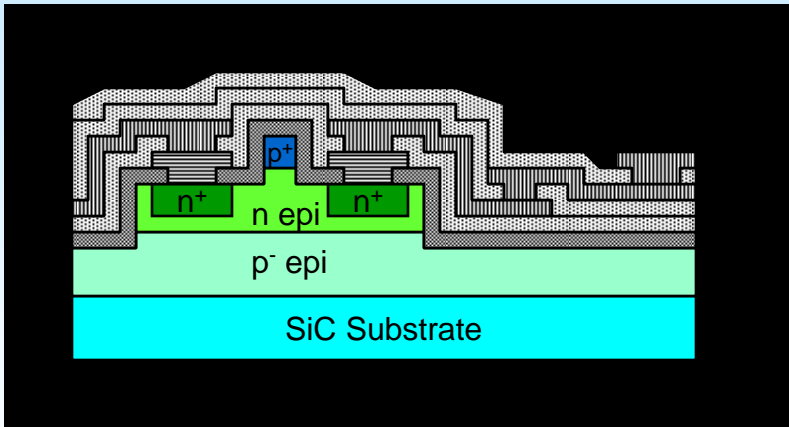



# Chip Level Packages for 500°C Application

AlN

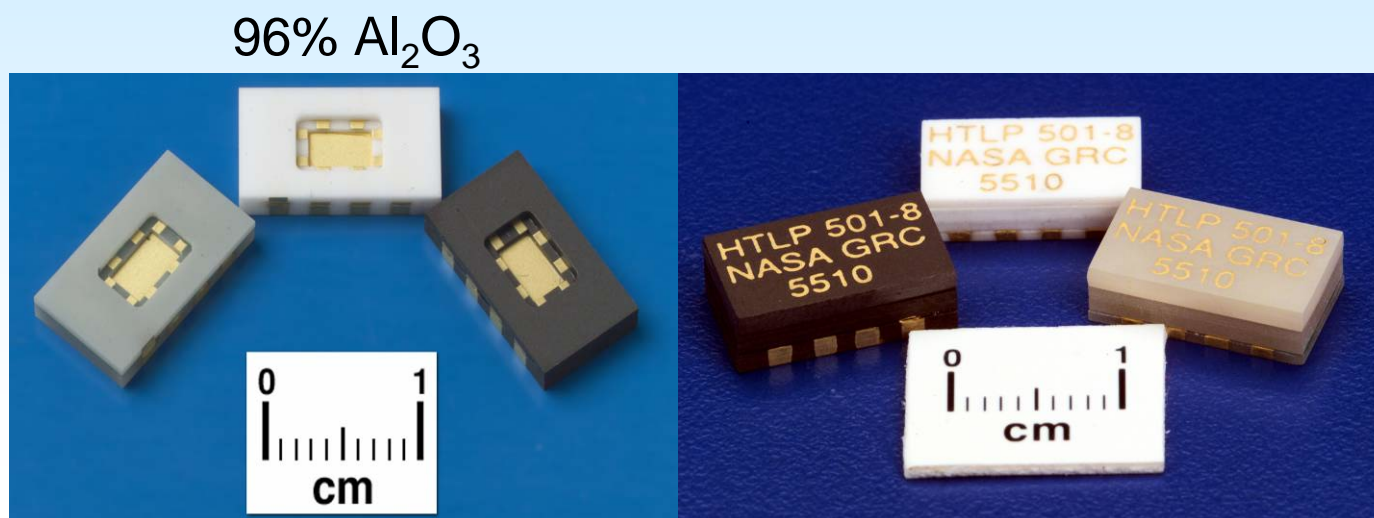

96%  $\text{Al}_2\text{O}_3$

90%  
 $\text{Al}_2\text{O}_3$

- Three types of ceramic substrate and Au thick-film metallization based chip-level packages
- A compatible low resistance die-attach scheme tested for 1000hrs
- Compatible printed circuit board level interconnection system developed

# WORLD'S FIRST 500 HOUR 500 °C TRANSISTOR WITH VERY STABLE OPERATION

- 2000 hours of transistor operation achieved (some limited degradation)
- Device Operation Also Demonstrates Viability of Supporting Technologies
  - Packaging and ohmic contacts operated over 2000 hours at 500 °C without degradation.
- Strong Foundation for Improved Device Operation
  - Revised “junction gate” process should enable 2000 hours at 500 °C without transistor degradation.

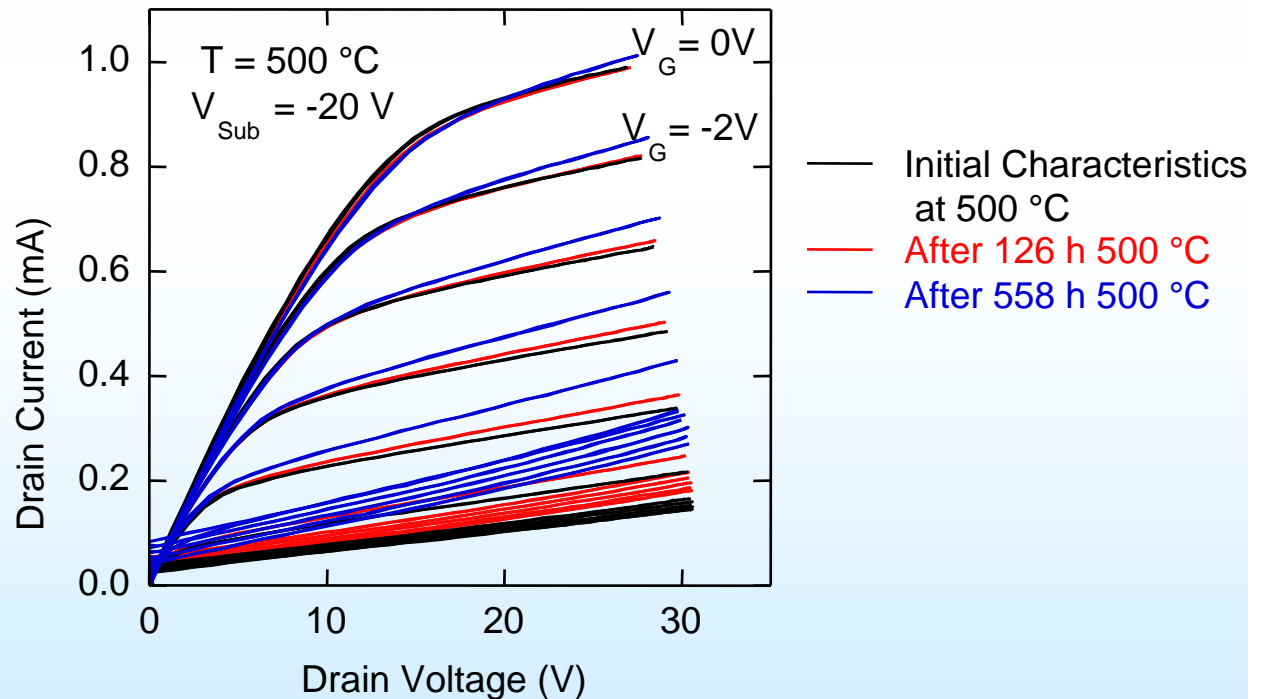
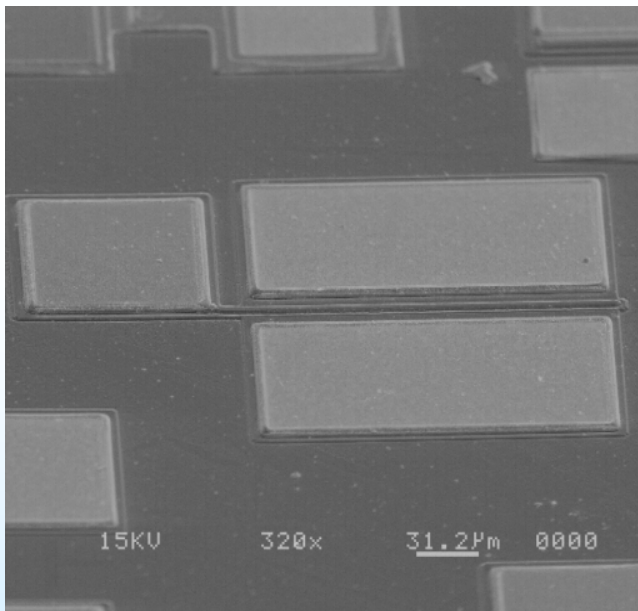

WORLD'S FIRST 500 C STABLE TRANSISTOR AND ITS PERFORMANCE OVER TIME

# Demonstration of 500°C AC Amplifier Based on SiC MESFET and Ceramic Packaging – Test assembly 2006



## Optical Picture of the Test Assembly

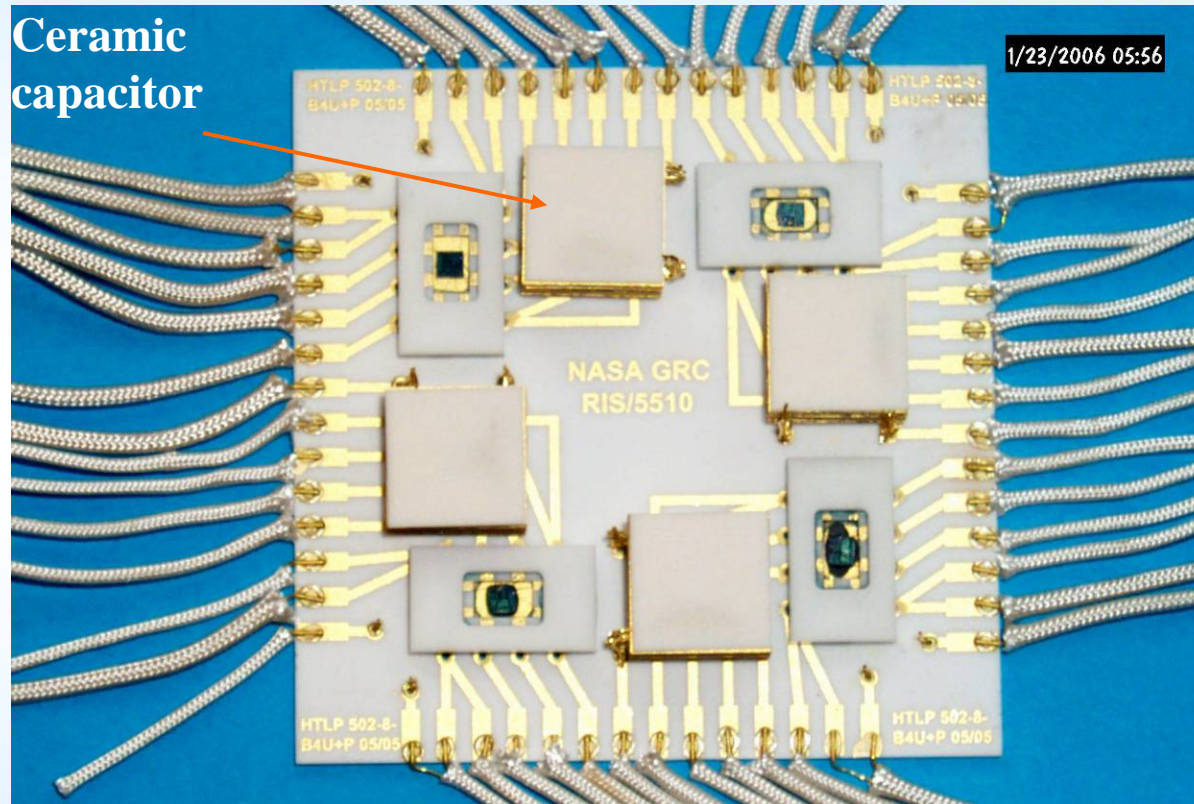

- The test assembly includes four testing circuit units
- Common - Source AC amplifier tested at 500 C for over 1100 hours





# High Temperature Wireless Development

## OBJECTIVES:

- HIGH TEMPERATURE WIRELESS TELEMETRY, DISTRIBUTED ELECTRONICS OVER A BROAD OPERATING RANGE

## TECHNICAL CHALLENGES:

- DEVELOPMENT OF RELIABLE HIGH TEMPERATURE TELEMETRY ELECTRONICS, POWER SOURCES, REMOTE COMMUNICATION ELECTRONICS, AND PACKAGING

## GOALS SUPPORTED:

- ENHANCE PERFORMANCE
- SIGNIFICANTLY REDUCE COST

PROVIDE DATA TRANSFER IN HARSH ENVIRONMENTS IMPROVING RELIABILITY AND ENABLING NEW CAPABILITIES

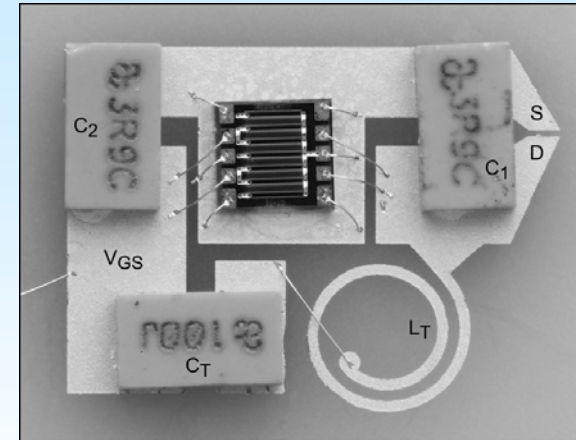

Prototype Oscillator Circuit

Example: Gas Turbine Engine Development Requires Extensive Instrumentation Yielding Extensive Wiring Complexity

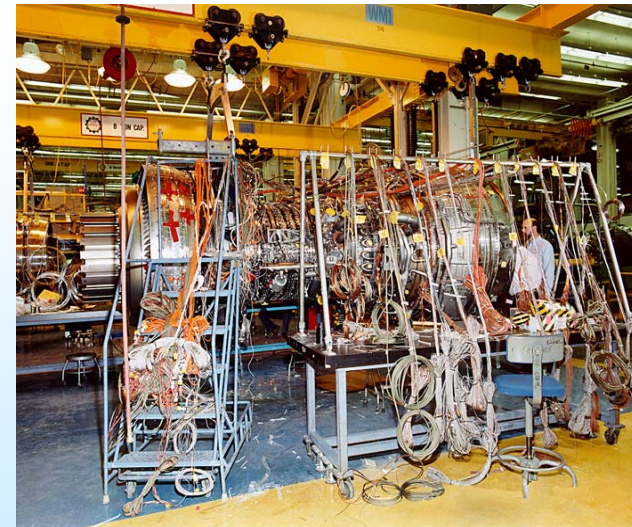

Wires from 1000 Sensors

# HIGH TEMPERATURE ELECTRONICS, COMMUNICATIONS, AND SENSORS BENEFITS TO NASA MISSIONS

Intelligent Propulsion Systems

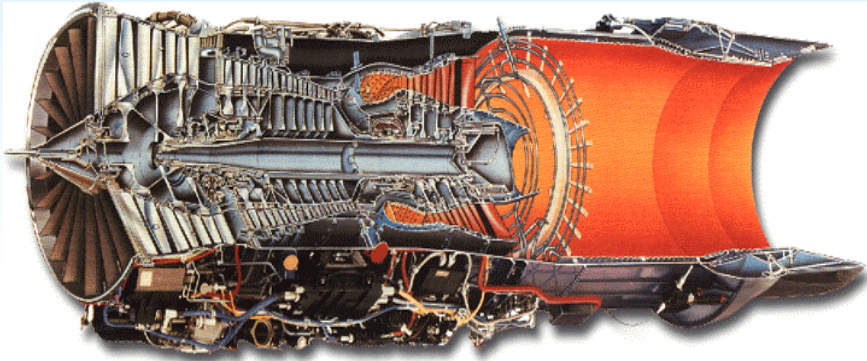

Space Exploration Vision PMAD



More Electric + Distributed Control Aircraft



Venus Exploration

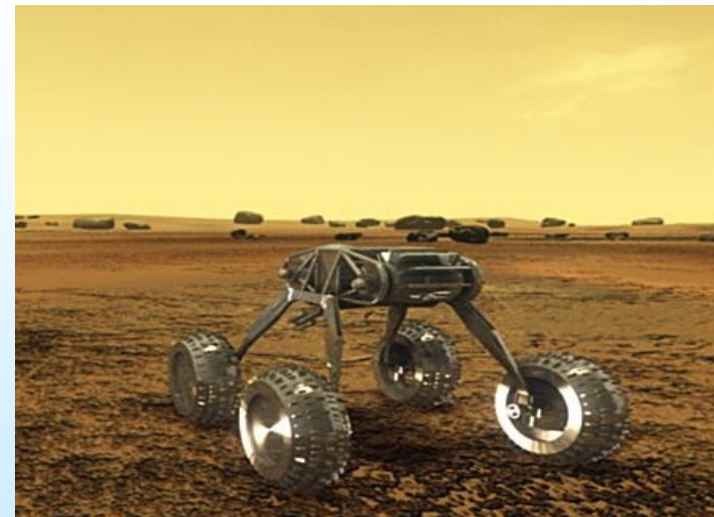



# HIGH TEMPERATURE WIRELESS AND SENSOR APPLICATION: VENUS

## EXAMPLE POSSIBLE MISSION: Venus Integrated Weather Sensor (VIWS) System

Sensor Suite to Monitor Venus Weather Conditions including: **Data Processing and Communication, Wind Flow, Seismic, Pressure/Temperature/Heat Flux, Chemical Environment**

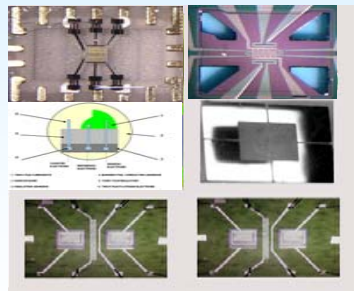

**HIGH TEMPERATURE ELECTRONIC NOSE (Chemical Species)**

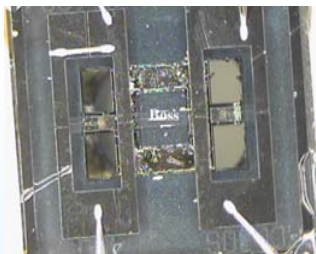

**Hi-g SiC ACCELEROMETER (Seismic Activities)**

**PRESSURE SENSOR (Pressure)**

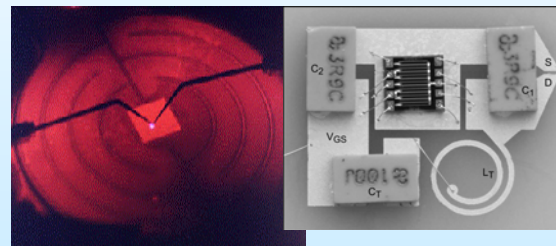

**SiC ELECTRONICS (Data Processing and Com)**

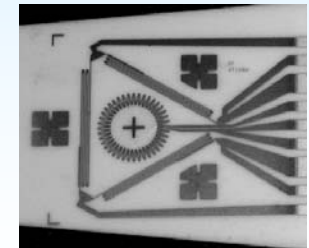
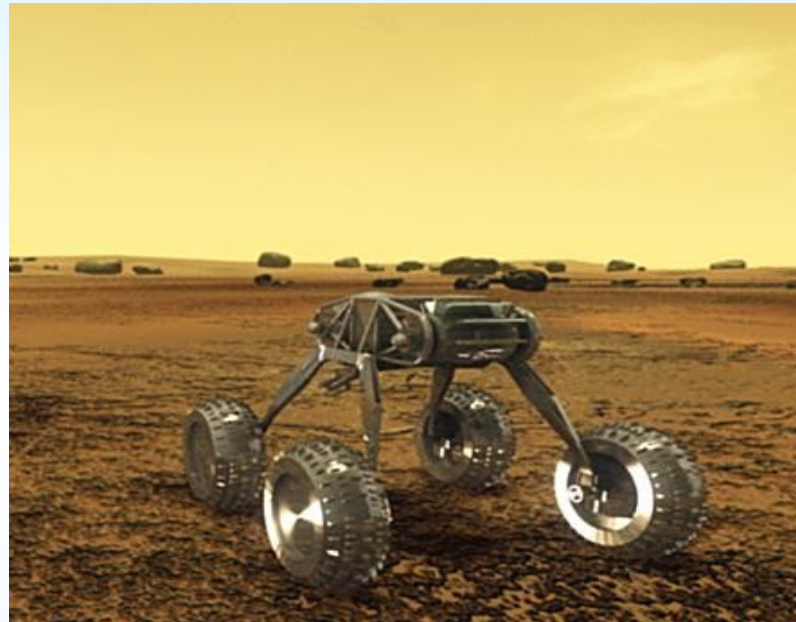

**MULTIFUNCTIONAL PHYSICAL SENSOR ARRAY (Temperature, Heat Flux)**

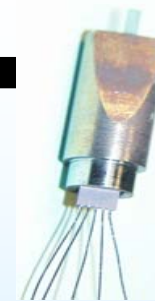

**HOTProbe (Wind flow, Pressure, Temperature)**

## SUMMARY

- ISHM/IVHM IS NECESSARY AND NOT JUST GOING TO SHOW UP WHEN NEEDED
- ONE INTELLIGENT SYSTEM APPROACH: SMART COMPONENTS (NODES) MADE POSSIBLE BY SMART SENSOR SYSTEMS
- SELF-AWARE COMPONENTS YIELD A SELF-AWARE SYSTEM
- TECHNOLOGY BEST APPLIED WITH STRONG INTERACTION WITH USER/TAILOR
- SENSOR FOR NEEDS OF APPLICATIONS SENSORS SHOULD BE INCLUDED AT THE BEGINNING OF THE DESIGN PROCESS RATHER THAN AS AN AFTERTHOUGHT
- WIRELESS PLAYS AN IMPORTANT ROLE IN LICK AND STICK TECHNOLOGIES (BOTH EARLY ON AND IF INCLUDED AS AN AFTERTHOUGHT)
- HARSH ENVIRONMENT RESULTS IN SPECIAL CHALLENGES FOR COMPONENT TECHNOLOGIES
- NASA GRC RESPONDS TO THE NEEDS OF SPACE AND AERONAUTIC APPLICATIONS WITH A WIDE RANGE OF HARSH ENVIRONMENT TECHNOLOGIES
- HIGH TEMPERATURE COMMUNICATIONS, SENSORS, ELECTRONICS, ACTUATORS, AND MICROSYSTEMS UNDER DEVELOPMENT
- LONG-TERM VISION FOR AN INTELLIGENT SYSTEM IS A SYSTEM THAT IS SELF-MONITORING, SELF-CORRECTING AND REPAIRING, AND SELF-MODIFYING INCLUDING HARSH ENVIRONMENT SYSTEMS.

