

617 550  
3/15/04

NASA/TM—2004-212908



# Overview 2003 of NASA Multi-D Stirling Convertor Code Development and DOE and NASA Stirling Regenerator R&D Efforts

Roy Tew  
Glenn Research Center, Cleveland, Ohio

Mounir Ibrahim  
Cleveland State University, Cleveland, Ohio

Terry Simon and Susan Mantell  
University of Minnesota, Minneapolis, Minnesota

David Gedeon  
Gedeon Associates, Athens, Ohio

Songgang Qiu  
Stirling Technology Company, Kennewick, Washington

Gary Wood  
Sunpower, Inc., Athens, Ohio

## The NASA STI Program Office . . . in Profile

Since its founding, NASA has been dedicated to the advancement of aeronautics and space science. The NASA Scientific and Technical Information (STI) Program Office plays a key part in helping NASA maintain this important role.

The NASA STI Program Office is operated by Langley Research Center, the Lead Center for NASA's scientific and technical information. The NASA STI Program Office provides access to the NASA STI Database, the largest collection of aeronautical and space science STI in the world. The Program Office is also NASA's institutional mechanism for disseminating the results of its research and development activities. These results are published by NASA in the NASA STI Report Series, which includes the following report types:

- **TECHNICAL PUBLICATION.** Reports of completed research or a major significant phase of research that present the results of NASA programs and include extensive data or theoretical analysis. Includes compilations of significant scientific and technical data and information deemed to be of continuing reference value. NASA's counterpart of peer-reviewed formal professional papers but has less stringent limitations on manuscript length and extent of graphic presentations.
- **TECHNICAL MEMORANDUM.** Scientific and technical findings that are preliminary or of specialized interest, e.g., quick release reports, working papers, and bibliographies that contain minimal annotation. Does not contain extensive analysis.
- **CONTRACTOR REPORT.** Scientific and technical findings by NASA-sponsored contractors and grantees.

- **CONFERENCE PUBLICATION.** Collected papers from scientific and technical conferences, symposia, seminars, or other meetings sponsored or cosponsored by NASA.
- **SPECIAL PUBLICATION.** Scientific, technical, or historical information from NASA programs, projects, and missions, often concerned with subjects having substantial public interest.
- **TECHNICAL TRANSLATION.** English-language translations of foreign scientific and technical material pertinent to NASA's mission.

Specialized services that complement the STI Program Office's diverse offerings include creating custom thesauri, building customized databases, organizing and publishing research results . . . even providing videos.

For more information about the NASA STI Program Office, see the following:

- Access the NASA STI Program Home Page at <http://www.sti.nasa.gov>
- E-mail your question via the Internet to [help@sti.nasa.gov](mailto:help@sti.nasa.gov)
- Fax your question to the NASA Access Help Desk at 301-621-0134
- Telephone the NASA Access Help Desk at 301-621-0390
- Write to:  
NASA Access Help Desk  
NASA Center for AeroSpace Information  
7121 Standard Drive  
Hanover, MD 21076



# Overview 2003 of NASA Multi-D Stirling Convertor Code Development and DOE and NASA Stirling Regenerator R&D Efforts

Roy Tew  
Glenn Research Center, Cleveland, Ohio

Mounir Ibrahim  
Cleveland State University, Cleveland, Ohio

Terry Simon and Susan Mantell  
University of Minnesota, Minneapolis, Minnesota

David Gedeon  
Gedeon Associates, Athens, Ohio

Songgang Qiu  
Stirling Technology Company, Kennewick, Washington

Gary Wood  
Sunpower, Inc., Athens, Ohio

Prepared for the  
Space Technology and Applications International Forum (STAIF-2004)  
sponsored by the American Institute of Physics  
Albuquerque, New Mexico, February 8-12, 2004

National Aeronautics and  
Space Administration

Glenn Research Center

## Acknowledgments

We would like to acknowledge the support for the work reported here that was received from the NASA Headquarters Offices of Aerospace Technology (Code R) and Space Science (Code S) and from DOE's Renewable Energy Laboratory in Golden, Colorado; the DOE technical monitors were first Lizana Pierce and then Steve Sargent. We also acknowledge the graduate students who did the research: At University of Minnesota—Yi Niu, regenerator research and David Adolphson, 90° turn research; at Cleveland State University—Wei Rong, regenerator modeling; Zhiguo Zhang and Sundeep Kembhavi, 90° turn modeling; and Zhiguo Zhang, 2-D and initial 3-D, Stirling code development.

This report contains preliminary findings, subject to revision as analysis proceeds.

Trade names or manufacturers' names are used in this report for identification only. This usage does not constitute an official endorsement, either expressed or implied, by the National Aeronautics and Space Administration.

Available from

NASA Center for Aerospace Information  
7121 Standard Drive  
Hanover, MD 21076

National Technical Information Service  
5285 Port Royal Road  
Springfield, VA 22100

Available electronically at <http://gltrs.grc.nasa.gov>

# Overview 2003 of NASA Multi-D Stirling Converter Code Development and DOE and NASA Stirling Regenerator R&D Efforts

Roy Tew  
National Aeronautics and Space Administration  
Glenn Research Center  
Cleveland, Ohio 44135

Mounir Ibrahim  
Cleveland State University  
Cleveland, Ohio 44115

Terry Simon and Susan Mantell  
University of Minnesota  
Minneapolis, Minnesota 55455

David Gedeon  
Gedeon Associates  
Athens, Ohio 45701

Songgang Qiu  
Stirling Technology Company  
Kennewick, Washington 99336

Gary Wood  
Sunpower, Inc.  
Athens, Ohio 45701-2625

## ABSTRACT

This paper will report on (1) continuation through the third year of a NASA grant for multi-dimensional Stirling CFD code development and validation, (2) continuation through the third and final year of a Department of Energy, Golden Field Office (DOE), regenerator research effort and a NASA grant for continuation of the effort through two additional years, and (3) a new NASA Research Award for design, microfabrication and testing of a "Next Generation Stirling Engine Regenerator." Cleveland State University (CSU) is the lead organization for all three efforts, with the University of Minnesota (UMN) and Gedeon Associates as subcontractors. The Stirling Technology Company and Sunpower, Inc. acted as unfunded consultants or participants through the third years of both the NASA multi-D code development and DOE regenerator research efforts; they will both be subcontractors on the new regenerator microfabrication contract.

## INTRODUCTION

A high-efficiency Stirling Radioisotope Generator (SRG) for use on potential NASA Space Science missions is being developed by the Department of Energy (DOE), Lockheed Martin, Stirling Technology Company (STC), and NASA Glenn Research Center (GRC). These missions may include providing spacecraft onboard electric power for deep space missions or power for unmanned Mars rovers. GRC is also developing advanced technology for Stirling converters, aimed at substantially improving the specific power and efficiency of the converter and the overall power system. Performance and mass improvement goals have been established for second- and third-generation Stirling radioisotope power systems. Multiple efforts are underway to achieve these goals, both in-house at GRC and under various grants and contracts. These efforts include development of a multi-dimensional Stirling computational fluid dynamics code, high-temperature materials, advanced controllers, an end-to-end system dynamics model, low-vibration techniques, advanced regenerators, and a lightweight converter (Thieme, 2003). The objective of this paper is to report on the NASA multi-D code development effort, a DOE regenerator research effort and NASA regenerator R&D efforts. The DOE effort was an important complement to the NASA efforts, as evidenced by the decision to continue it under NASA funding.

## MULTI-DIMENSIONAL STIRLING CODE DEVELOPMENT AND VALIDATION

A grant to Cleveland State University (CSU) for Stirling multi-D code development and validation will continue through at least a 4<sup>th</sup> year, ending July, 2004. Principal Investigators (PI's) are Mounir Ibrahim (CSU, and overall), Terry Simon (University of Minnesota, or UMN) and David Gedeon of Gedeon Associates.

Much of the regenerator modeling effort has been done under a complementary three-year DOE regenerator research effort which ended August, 2003. This work is continuing via a two-year NASA grant starting October 2003.

The commercial CFD-ACE code, developed by CFD Research Corp. (CFDRC) of Huntsville, AL, is being used for code development. Validation of the codes with test data taken in large-scale test rigs at UMN, and data taken from the literature, is an important part of the Stirling code development.

As a part of a separate grant with CSU for "2<sup>nd</sup> Law Analysis, via Sage and CFD-ACE models, of MIT Gas Spring and 'Two-Space' Test Rigs," another look will be taken at the comparison of 1-D and 2-D models of these two MIT test rigs with the experimental data (Kornhauser, 1989). Previous comparisons were reported in Ibrahim (2001). This "2<sup>nd</sup> Law Analysis" grant, with Asuquo Ebiana of CSU as PI, will run through at least a 2<sup>nd</sup> year, ending November, 2004. There is a possibility that the effort will be extended to encompass application of 2<sup>nd</sup> law analysis to a 2-D model of a complete Stirling engine.

### Two-Dimensional Model of Stirling Converter (or Engine/Alternator)

CSU has developed a 2-D model of a Stirling engine (see Fig. 1). The model includes oscillating power piston and displacer; variable volume compression and expansion spaces; heater, cooler and regenerator; the full pressure-vessel walls around these heat exchangers; and pressure-vessel walls around the expansion and compressions spaces using approximately thermal penetration thickness over the engine cycle. The major 2-D simplifications of the geometry are: (1) the radial fins and flow passages of the heater and cooler are replaced by fins and flow passages concentric about the Stirling cylinder axis; total flow area, fin cross-sectional area, heat transfer area, and hydraulic diameter are approximated as closely as possible by choice of the number and size of concentric fins and flow passages, (2) Four symmetrically arranged holes in the base or "spider" supporting the displacer rod, are replaced by an annular opening, and (3) the regenerator matrix is modeled via a macroscopic porous media model. Development of appendix gap and displacer seal models are underway.

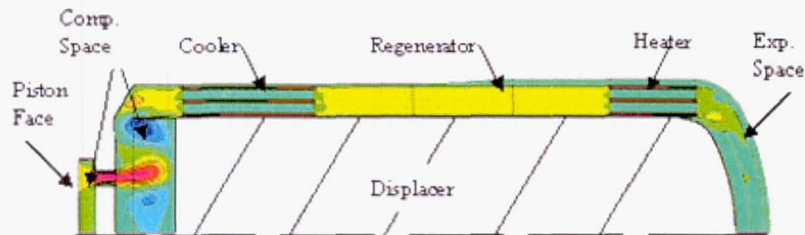

FIGURE 1. 2-D Stirling Converter Schematic with Velocity Contours.

During the past year the CSU 2-D model was used to do an initial study of the heat transfer interaction between the pressure vessel wall and the regenerator. It was anticipated that little interaction between wall and regenerator would be observed via the calculations. However, substantial interaction was indicated. Thus, questions have

been raised about the accuracy of the molecular conductivity assumed in the porous media model. And, it was learned that thermal dispersion, due to small turbulent-like eddies within the regenerator (which tend to enhance the effective conductivity), is not accounted for. Also, the assumption of thermal equilibrium between gas and matrix may make it impossible to accurately predict the enthalpy flux over an engine cycle, from hot to cold end of the regenerator. Other "mysterious results" were: (1) for one case that was run close to convergence, without pressure-vessel walls included, enthalpy flux was from cold to hot end of the regenerator, apparently violating the 2<sup>nd</sup> law of thermodynamics, but (2) this did not occur for another case run close to convergence, when the pressure vessel walls were included. Work is underway to try to understand these "strange" results. It's possible that some modeling error may explain the results. However, due to the known uncertainties and limitations of the porous media model, it seems likely that an improved porous media model may be required.

Sundip Mazumder of CFDRC suggested in a private conversation that it might be possible to overcome the assumption of thermal equilibrium in the porous media module by using: (1) the CFD-ACE porous media module to represent the fluid portion of the matrix, and (2) the CFD-ACE scalar module to represent the solid portion. But, this would require the assumption of heat-transfer and friction-factor correlations between solid and fluid portions of the regenerator and would amount to inserting a 1-D regenerator model into the 2-D model of the rest of the engine. Although this would degrade somewhat the claim to having a 2-D model of a Stirling engine, it might allow useful things to be learned about the 2-D portions of the engine model.

Conversion of the 2-D CSU model to a model of the Technology Demonstration Converter (TDC), an STC Stirling design, is underway at GRC by Scott Wilson of Sest, Inc. Immediate plans are to complete the conversion and develop a plan for use of the 2-D TDC model to study internal engine flow and heat transfer. TDC 2-D predictions will be compared with engine data and with 1-D Sage model (Gedeon, 1999) predictions.

### Update on “90 Degree Turn” Code Validation Experiments and CFD Modeling

“90 Degree Turn” test rig flow visualization data and data/CFD comparisons, as representations of flows into Stirling compression and expansion spaces, were reported in Adolfson (2002) and Ibrahim (2002a), and summarized in Tew (2003). Here, some of the results of hot-wire measurements of velocity and turbulence intensity, and CFD comparisons with these data, are taken directly from the latest reports by Adolfson (2003) and Ibrahim (2003a).

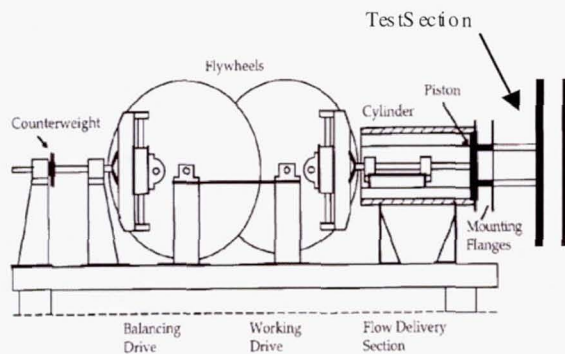

FIGURE 2. UMN Scotch Yoke Drive Facility.

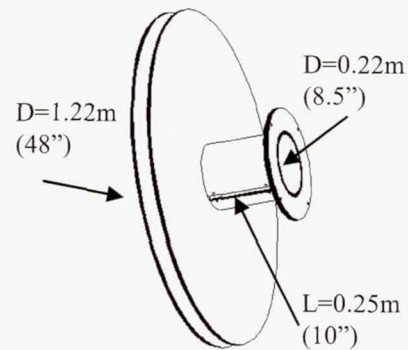

FIGURE 3. Test Section.

Adolfson (2003) describes the test facility schematic in Fig. 2 as follows: “A Scotch yoke drive is used to develop sinusoidal piston motion of rotational frequency,  $\omega$ , ranging from 4 to 120 revolutions per minute (RPM). The test section of Fig. 2 is shown in Fig. 3. The delivery tube inner diameter,  $D$ , matches the piston diameter. The two large discs have a major diameter of 1.22 m. The disc diameter is large to minimize flow momentum in and out of the test section. The tube attached to the right disc in Fig. 3 is 0.25 m in length. At top dead center, (the furthest position that the piston achieves in the cylinder) the piston face is flush with the tube inlet plane. The distance between the two large discs is variable from 0.025 m (1 inch) to 0.127 m (5 inches).”

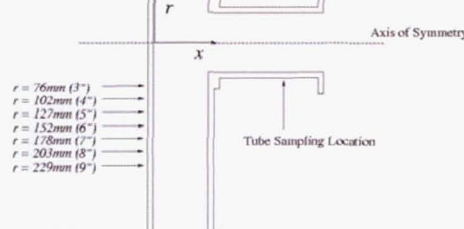

FIGURE 4. Sampling Locations and Coordinate Conventions.

A hot-wire anemometer was used for data collection. Adolfson (2003) reports that, “Velocity and turbulence intensity (TI) profiles were documented by traversing the probe within the test section. A single traverse was taken within the delivery tube and several were taken within the disc space (see Fig. 4). Disc space traverses were (following the convention of Fig. 4) in the  $x$ -direction. The single traverse in the tube space was in the  $r$ -direction. The coordinate origin is taken on the tube centerline (the “Axis of Symmetry”) at the target (left in Fig. 4) disc. The sequence of spatial points in a given traverse was randomized to prevent any temporal changes from being interpreted as

spatial trends.” Also, “The raw data were ensemble averaged over 100 cycles to produce velocity and TI values resolved in time within the cycle at each measurement station.”

Sample data is shown here, taken from Adolfson (2003), for one of the test cases, Case II.a. Case II.a data was taken at 30 RPM, Maximum Reynolds No. of 7600, disk spacing of 127 mm (5 inches), Valensi No. (dimensionless frequency) = 2300 in the Tube, as defined in Figure 4. Velocity data is shown in Figure 5. and Turbulence Intensity, TI, data is shown in Figure 6. Adolfson notes that a hot-wire is unable to resolve flow direction, hence,  $\|u\| = (\vec{u} \cdot \vec{u})^{1/2}$  is plotted in Figure 5. Note also that  $r$  is normalized on the tube diameter,  $D$ .

Adolfson (2003) describes Figures 5 and 6 as follows: “Figure 5 shows that on the intake portion of the cycle,  $0 < \theta < 180$ , the velocity near the tube walls is of a higher absolute value than the core flow velocity. This suggests that some of the momentum, on average, from the previous cycle is retained in the core flow and, thus, the core is slower to respond to changes in pressure gradient imposed by the piston. Viscous forces near the wall reduce the momentum of the fluid and allow it to respond more quickly to changes in the pressure field. The exhaust portion of the cycle  $180 < \theta < 360$  is somewhat different. Here the flow is being driven out of the tube by the piston. It seems that for this case, the flow behaves like a developing pipe flow, with the average centerline flow velocity following the piston velocity. Figure 6 presents a plot of turbulence intensity in the tube space. Because  $TI = u_{rms} / \|u\|$  is plotted, as velocity decreases, TI tends to increase. Periods of strong acceleration (e.g.  $0^\circ < \theta < 45^\circ$ ) show dissipation of turbulence, whereas periods of deceleration (e.g.  $90^\circ < \theta < 135^\circ$ ) show large production of turbulence. Flow visualization in the tube space (Adolfson, 2002) support this result.”

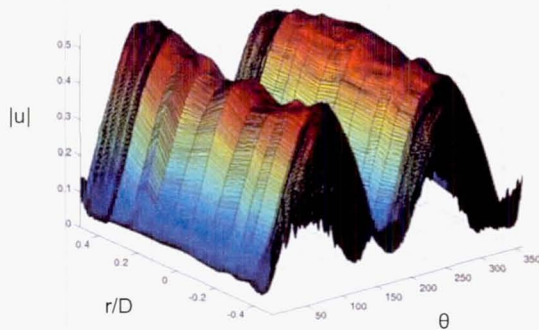

**FIGURE 5.** Velocity Profile in the Tube for Case II.a.

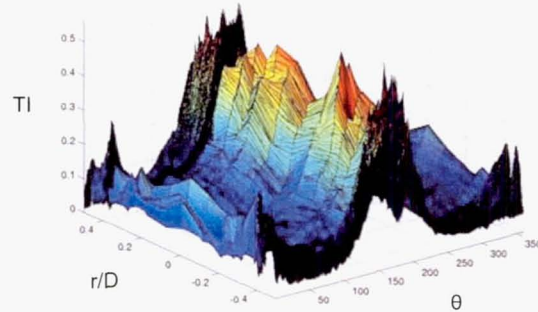

**FIGURE 6.** Turbulence Intensity Profile in Tube for Case II.a.

Results are also shown in Adolfson (2003) of x-traverses of the disk, taken at one radial location (measurements were actually taken at various radial locations). Again, velocity and turbulence intensity profiles were measured.

Adolfson (2003) also reports on a complementary jet impingement experiment conducted in the geometry of the current study, but under unidirectional flow conditions for several Reynolds number and disc spacing combinations. Comparisons are shown of unidirectional and oscillating-flow velocities at the same Reynolds number (there are two cases of the same oscillating-flow Reynolds number, one with accelerating and one with decelerating piston). Two of the conclusions of the unidirectional/oscillating-flow comparison are (1) unsteady flow effects govern the flow field and (2) although the piston follows an exact sinusoid there is no reason to expect the same of the flow field; the flow velocity lags behind the piston velocity and large-scale separation zones, recirculation bubbles, unsteady shear layers and spatially varying transition and relaminarization zones are observed. Tentative plans are being made to publish the detailed results in Adolfson’s thesis as a NASA Contractor’s report with movies, graphics and data included on a CD-ROM.

Ibrahim (2003a) reports on CFD results generated using models of the UMN test rig for unidirectional and oscillatory-flow. The UMN rig was modeled using (1) laminar flow, (2) a  $K-\omega$  turbulence model and c) a  $K-\epsilon$



turbulence model. K- $\omega$  model results were in much better agreement with the data than for the K- $\epsilon$  model (not shown in this paper).

Ibrahim (2003a) describes the unidirectional flow comparison between CFD results (Streamlines and Velocity Vectors) and UMN Experiments (Flow Visualization) for a Maximum Reynolds number of 7600 and a disk spacing of 0.127 m: "Figure 7 shows CFD results using laminar and K- $\omega$  turbulent flow models together with the flow visualization test results conducted at UMN for the case of 0.127 m spacing and  $Re_D=7600$ . As the flow turns into the channel, a large-scale vortex is created between the two discs. The flow accelerates from the stagnation zone, with additional acceleration due to the vortex generated between the two discs. Near  $r/R = 1$  ( $r$  is the radial location from axis of symmetry and  $R$  is the tube radius) the flow starts to decelerate due to the increase in the flow area. The CFD results using the K- $\omega$  model seem to predict these flow features very well. On the other hand the laminar flow model shows only a thin flow layer near the right disc and not enough mixing to spread the flow across the channel."

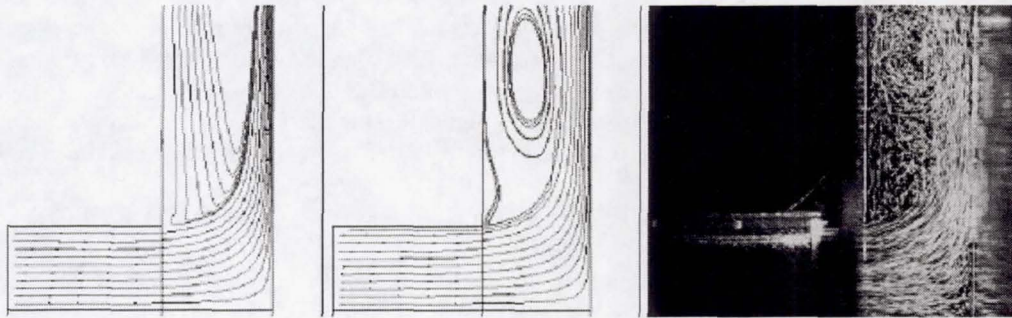

**FIGURE 7.** Comparison Between CFD (Streamlines and Velocity Vectors) and UMN Experiments (Flow Visualization), Disk Spacing =0.127 m, Maximum Reynolds number=7600.

Ibrahim (2003a) describes the unidirectional velocity comparisons between CFD calculations and data in Figure 8 as follows: "Figure 8 shows velocity measurements (using hot-wire anemometry also conducted at UMN) at four radial locations, for  $S=0.127$  m and  $Re_D=7600$ . Figure 8a is for radial location,  $r=0.1016$  m. Shown are the experimental data and two predictions, one laminar and the other made with the K- $\omega$  turbulence model. The "x-axis" is the axial flow direction normalized with the disc spacing, with zero being at the target disc and 1 at the disc at the tube exit.

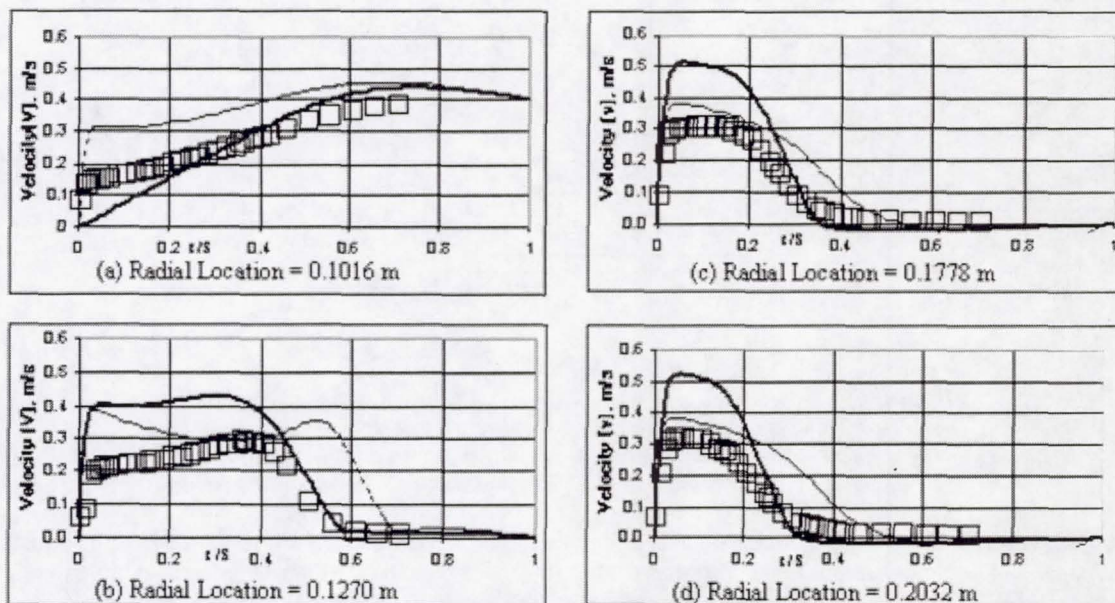

**FIGURE 8.** Comparison Between Experimental Velocity Data (UMN), Symbols, and CFD Results, Unidirectional Flow, Laminar, Solid Lines & K- $\omega$ , Dotted Lines, Turbulent Flow Models at Different Radial Locations:  $S=127$ mm and  $Re_D=7600$ .

The predictions are given for the velocity vector,  $V$ , since the flow is both in the radial and axial directions. Here, near the wall region, the  $K-\omega$  model is in closer agreement with the experiment. The laminar flow is in a better agreement with the data a distance away from the wall. Figure 8b shows a similar plot to the one shown in 8a but at  $r = 0.127$  m. The laminar flow seems to be in overall better agreement with the data than the  $K-\omega$  model results. Figures 8c and d show the CFD data for the radial velocity component,  $V$ . Here, we see the predictions using the  $K-\omega$  model are in closer agreement with the experiment. This is consistent with the discussion shown earlier for Figure 7, where the vortex was predicted well using the  $K-\omega$  model and more spread of the velocity fields is noticed at higher radial locations.”

Flow visualization comparisons were shown previously in Ibrahim (2002a) and more are shown in Ibrahim (2003a). Conclusions of CFD and test data comparisons for the 90 deg. turn test rig were: (1) For unidirectional flow, the  $K-\omega$  turbulence model shows similar results to the flow visualization data including size and location of the vortex. The laminar flow does not show these flow features. (2) The comparison between the test data (flow visualization and velocity) and the CFD data shows the laminar flow model is in closer agreement near the stagnation region. At radial distances further from the stagnation region, the  $K-\omega$  model shows better agreement. (3) The above statements are true for unidirectional flow. For oscillatory flow there was little difference between laminar and  $K-\omega$  models. (4) Therefore, it seems a model is needed that will accommodate laminar flow in the stagnation region and turbulence some distance away from this region. A single model with transition capabilities would be even better.

### DOE, PLUS NASA FOLLOW-ON, REGENERATOR RESEARCH EFFORTS

Regenerator tests are ongoing at UMN, in an attempt to understand the fluid mechanics in screen and random-fiber regenerators. Fig. 9 shows a schematic of the UMN regenerator test section. The facility consists of an oscillating flow generator, a flow distributor, an air-water cooler, a regenerator, an electrical heater and an isolation duct. The piston is driven by the same scotch yoke driver shown in Fig. 2. The present regenerator experiments are run at a frequency of 0.4 Hz, a stroke of 356 mm and a piston diameter of 356 mm. A detailed description of the test section, including the large-scale regenerator mesh dimensions and arrangement, is given in Niu (2002, 2003a, 2003b, 2003c). The three cooler tubes shown are part of a 3x3 rectangular array. Note the plenum between the cooler tubes and regenerator matrix whose length can be varied to study the effect on jetting of flow from the cooler tubes into the matrix. Hot-wire anemometry has been used to measure velocities at the axial center of the plenum and temperatures both within the plenum and within the regenerator matrix. A representative Stirling engine was chosen for definition of test section design dimensionless parameters (e.g., maximum Reynolds number and Valensi number).

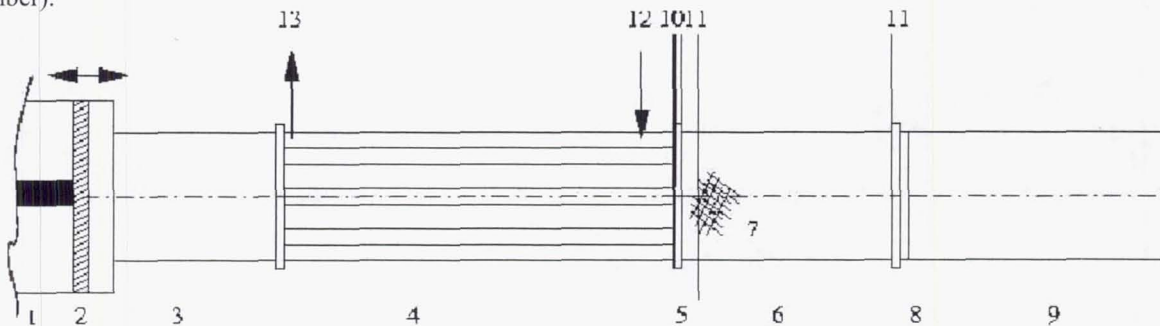

**FIGURE 9.** The Schematic of the UMN Experimental Facility and the Test Section.  
 1----oscillatory flow generator, 2----piston, 3----flow distributor, 4----cooler, 5----plenum,  
 6----regenerator, 7----screen matrix, 8----electrical heating coil, 9----isolation duct,  
 10----hot-wire, 11----thermocouple, 12----cooling water in, 13----cooling water out

Niu (2003c) reported that: “The regenerator matrix consists of two hundred layers of 6.3 mm x 6.3 mm square mesh, stainless steel 304, welded screens. The wire diameter,  $d_w$  of the screens is 0.81 mm, which is small enough for the wire to be nearly radially-isothermal. The interstitial spaces are small enough and the dispersion is strong enough for the flow and thermal fields within a given interstice to be uniform [over most of the cycle]. The screens are stacked so that each layer is rotated 45° from the adjacent layer and so that the regenerator has 90% porosity. The screen is punched out of welded screen sheets so that the center of the disc is random with respect to the center of the mesh in

which it resides. Between the cooler exit plane and the regenerator inlet plane is a plenum space, 190 mm in diameter. The plenum space is created by several spacers of the same nominal thickness. The nominal thickness of one spacer is determined so that the radial-flow area,  $\pi d_c \delta$ , equates to the axial-flow area,  $\pi d_c^2$ . This gives a nominal width,  $\delta$  of 4.76 mm [ $d_c$ =cooler tube diameter]. Multiple spacers of this thickness could be combined to vary this space in multiples of  $\delta$ . Therefore, the plenum size is determined by the total thickness of the spacers plus the thickness of one washer,  $0.33\delta$  that is bolted onto the regenerator to hold the screens axially. To investigate the effect of the plenum size on the jet penetration, temperature measurements were conducted on three cases: Case I (Base Case), plenum thickness =  $1.33\delta$ ; Case II, plenum thickness = 0; and Case III, plenum thickness =  $4.33\delta$ .

Niu (2003c) describes velocity profile results for cases I and III as follows: “[Figures 10 and 11] illustrate the velocity profiles at crank angles of 210°, 240°, 270°, 300° and 330° during the blowing half cycle for the cases I and III. It is observed that the maximum velocity takes place at the crank angle of 270°, as expected. It is seen that three similar velocity profiles are repeated across the three cooler tubes, verifying uniformity of flow to the cooler tubes.

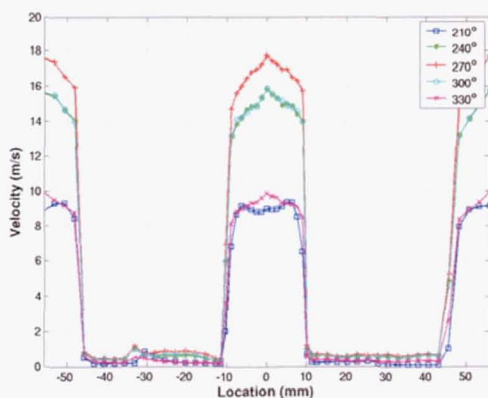

FIGURE 10. Velocity Profiles during the Blowing Half Cycle with the Plenum for Case I ( $1.33\delta$ ).

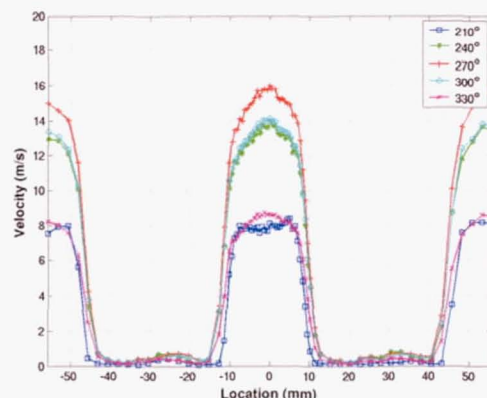

FIGURE 11. Velocity Profiles during the Blowing Half Cycle with the Plenum for Case III ( $4.33\delta$ ).

A comparison between the two figures shows that the maximum mean velocity (about 16m/s) in case III is smaller than that in case I (about 17.8 m/s). Also, the width of the jets slightly increases in case III because the wider plenum spacing allows the jets to travel further before they impinge onto the regenerator matrix.”

Niu (2003c) also shows results of the measurements of temperature distributions within the plenum and the thermal entrance region of the matrix for the different plenum sizes. The jets spread only slightly within the plenum, but spread at a wide angle as they enter the regenerator matrix. They then grow more slowly and eventually reach a linear growth rate before merging. The fraction of the matrix material not participating in heat transfer was calculated for each case and was weakly dependent on plenum size for the range covered in these experiments (and for the 90% porosity matrix). The effect of thermal dispersion was also investigated, indirectly, by comparing the jet spreading to a free turbulent circular jet. The estimated eddy diffusivity due to dispersion in a real engine would be 40-90 times the molecular diffusivity in that environment.

In a separate paper, Niu (2003b) discusses the results of time dependent temperature measurements of the matrix wire and fluid, and determination of the heat transfer rates and Nusselt numbers for heat transfer between the fluid and wire. Results for Nusselt No. and heat transfer rates are compared with those determined from steady-flow correlations in Figures 12 and 13. The steady-flow correlations from Sage and Kays and London’s “Compact Heat Exchangers” used for comparison with the results of the present study were  $Nu = (1 + 0.99 Re^{0.66} Pr^{0.66}) p^{1.79}$  and  $Nu = 0.06 Re Pr^{1/3}$ , respectively, where Nu, Re and Pr are the dimensionless Nusselt, Reynolds and Prandtl numbers.

Niu (2003b) notes that, “Comparisons between the present experimental results and the correlations show agreement during the deceleration part of a cycle from 90° to 180° and from 270° to 360°. During acceleration, a significant

disagreement is observed. Different heat transfer behavior due to flow acceleration also was observed in an oscillatory pipe in previous research (Qiu, 1994).” Temperature plots shown indicated that the maxima and minima of the fluid temperature variations led those of the wire temperature by about 50°. Conclusions were: (1) The solid temperature is 90° out of phase with the piston face velocity, (2) local variations in heat transfer coefficient from one spatial location to another were small, (3) Nusselt number and heat fluxes of the present study agreed well with those determined from the two steady-flow correlations during flow deceleration but not during flow acceleration, and (4) possible reasons for the discrepancy during acceleration are persistence of eddies left from the previous half-cycle and enhancement of heat transfer as a result of flow acceleration.

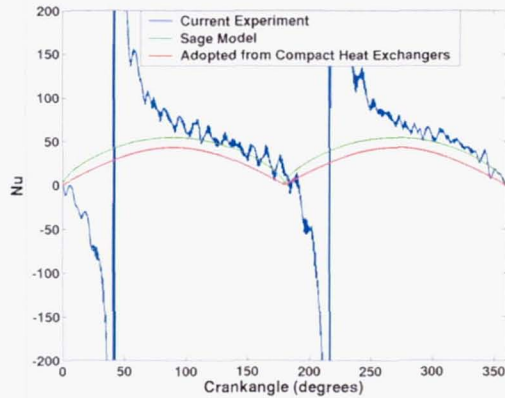

**FIGURE 12.** Comparison of Nu Numbers between Present Study and Steady-flow Correlations.

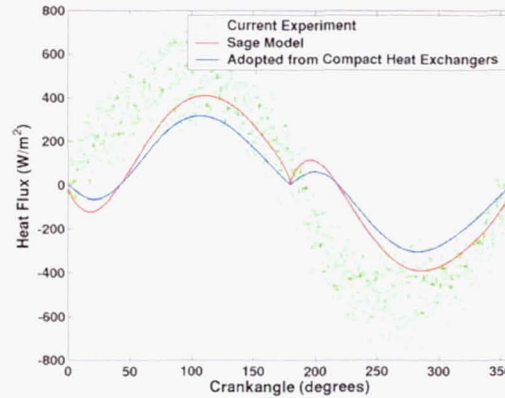

**FIGURE 13.** Comparison of Heat Flux between Present Study and Steady-flow Correlations.

Ibrahim (2003b) reports on CSU’s CFD modeling of the UMN unsteady heat transfer experiments. CSU modeled eight cylinders in cross flow with a staggered arrangement and inlet/outlet plenums. The CSU model matched UMN’s test section for wire diameter, inlet velocity, flow-oscillation frequency and matrix porosity. A laminar-flow CFD model was used to make comparison’s with UMN’s unidirectional flow measurements, unidirectional heat transfer correlations from the literature and UMN’s oscillatory flow heat transfer measurements as summarized above. CSU’s steady-flow results compared well with UMN flow and literature heat transfer results. The oscillatory CFD results showed phase angle and magnitude differences compared with the UMN data, but looked more like the UMN oscillatory-flow Nusselt number and heat transfer results than those determined from the Sage and Kay’s and London steady-flow correlations.

Plans for the two-year NASA continuation of the DOE regenerator research effort include extension of the large-scale regenerator testing at UMN from a regenerator matrix of 90% porosity to one of 95%, direct measurement of thermal dispersion in the regenerator, investigation of the effect of various heat exchanger tube exit geometries on jetting into the matrix, continued regenerator CFD modeling at CSU, and heat transfer and pressure drop testing of random fiber regenerators with porosities as high as ~95% in the NASA oscillating-flow test rig on loan to Sunpower.

## **REGENERATOR MICROFABRICATON CONTRACT**

A Radioisotope Power Conversion Technology NRA Contract was awarded to CSU and it’s subcontractors effective July 16, 2003, as part of NASA’s Project Prometheus, the Nuclear Systems Program. The basic contract period is for one year, with options for continuation into 2<sup>nd</sup> and 3<sup>rd</sup> years if progress is judged adequate. The purpose of the contract is to design and fabricate “The Next Generation Stirling Engine Regenerator,” based on microfabrication techniques.

Tasks for the first year included in the Statement of Work are: select regenerator matrix design, manufacturing vendor and microfabrication technique; verify viability of manufacturing technique; develop preliminary design of a Large Scale Mock Up (LSMU) of the chosen regenerator design for testing at UMN; modify and qualify the UMN oscillating-flow facility to accept the LSMU; formulate preliminary test plan for the LSMU; develop CFD model of the LSMU; show applicability of large-scale fluid mechanics, as in the LSMU, to that of an engine-sized

regenerator; estimate engine performance improvement realizable via this microfabrication effort; and prepare required technical and financial reports and mid-term and annual oral reviews. Second-year tasks are: finalize LSMU design & test plan; test LSMU; continue CFD modeling of LSMU; fabricate prototype proof-of-concept regenerator with actual-size features; microscopically inspect prototype to ascertain features fall within desired specifications; investigate how the selected microfabrication technique can be extended to fabricate an integrated heater/regenerator/cooler assembly; and required reporting and presentations. Third-year tasks are: fabricate regenerator with actual-size features for testing in the Sunpower oscillating-flow test rig and do the testing; fabricate a regenerator of the appropriate size for testing in a chosen Stirling converter and do the engine testing; continue LSMU testing and CFD modeling; design an integrated heater/regenerator/cooler for testing in a chosen Stirling converter; and preparation of required reports and presentations.

A progress report as of Sept. 2003 is as follows: Several potential microscale regenerator designs (and associated manufacturing techniques) are under consideration. These designs can be broadly grouped into three categories: (1) lenticular, or lentil-shaped, arrays; these "lentils" are shaped somewhat like airfoils, (2) uniformly separated plates or "foil", and (3) variations of current random-fiber technology. Several potential manufacturing processes (and manufacturers) have been identified including: selective laser sintering (University of Texas at Austin), stamping with dimples (Creare), lithographic microfabrication process, or LIGA (3M, Sandia, Mezzo Systems), and fiber mat dispersion (Baekert, Auburn University). Preparation is underway for interviews with various manufacturers, via trying to settle on geometries and materials. A report is in preparation that describes dynamic similarity parameters that characterize testing of scaled-up regenerators and Stirling system scaling in general.

Gedeon (2003a) has developed a figure of merit that includes the effects of heat transfer, including thermal dispersion, and flow resistance. Gedeon (2003b) has also completed an initial investigation of the potential benefit of a micro-fabricated regenerator. His computations, based on optimizations using the Sage code, showed 8.6% power and efficiency increases (for the same heat input) when an ideal foil regenerator (Sage approximation of the planned microfabricated regenerator) was used instead of a random-fiber regenerator. A third Gedeon memo, Gedeon (2003c), shows solid models and drawings of alternatives to the originally proposed lenticular array; these include (1) a thin-walled honeycomb structure suitable for the LIGA process, (2) an embossed involute-foil structure suitable for the Creare precision stamping process, and (3) a flat-ribbon random-wire structure with preferred orientations of both fiber axis and chord angles with respect to the flow direction. These solid models, dimensions and geometries of the lenticular and alternative geometries will be used to provide information to manufacturers to get feedback regarding manufacturing feasibility.

## CONCLUDING REMARKS

The results of several advanced Stirling technology efforts have been summarized. The goals are improvements in Stirling converter performance via (1) development and validation of multi-dimensional Stirling CFD models, (2) experimental and computational research to investigate regenerator fluid-flow and heat transfer phenomena, and (3) development of a new improved regenerator via microfabrication. Progress and problems associated with continued development of two-dimensional Stirling engine models and the experiments being conducted to validate the models are reported. Experimental and computational regenerator research supported by DOE and NASA, and some initial information about a new NASA contract to support development of a new type of Stirling regenerator via microfabrication are reported.

## REFERENCES

- Adolfson, D.A., Simon, T.W., Ibrahim, M.B., and Gedeon, D., "Measurements in Oscillatory Flows with Separation in Support of Stirling Engine Model Development," *Proceedings of the 37<sup>th</sup> Intersociety Energy Conversion Engineering Conference*, Washington, D.C., IECEC 2002 Paper No. 20142, (2002).
- Adolfson, D.A., Simon, T.W., Ibrahim, M.B., and Gedeon, D., "Unsteady Fluid Dynamics Simulation of a Stirling Engine Heater Head," *Proceedings of the 1st International Energy Conversion Engineering Conference*, Portsmouth, VA, Paper No. AIAA-2003-5934, (2003).
- Gedeon, D., "Sage User's Guide," 3<sup>rd</sup> Edition, Gedeon Associates, 16922 South Canaan Road, Athens, OH 45701, (1999).
- Gedeon, D., Private Memorandum, "Regenerator Figures of Merit," (2003a).
- Gedeon, D., Private Memorandum, "Potential 9% Power Increase for a Micro-fabricated Regenerator in a 100W-sized Space-power Engine," (2003b).
- Gedeon, D., Private Memorandum, "Alternative Micro-fabricated Regenerator Matrices," (2003c).

- Ibrahim, M.B., Tew, R.C., Zhang, Z., Gedeon, D., and Simon, T.W., "CFD Modeling of Free-Piston Stirling Engines," *Proceedings of the 36<sup>th</sup> Intersociety Energy Conversion Engineering Conference*, Savannah, GA, 2001 (IECEC2001-CT-38), NASA/TM-2001-211132, 2001.
- Ibrahim, M.B., Zhang, Z., Kembhavi, S., Simon, T.W., and Gedeon, D., "A 2-D Axisymmetric CFD Model of Oscillatory Flow with Separation," *Proceedings of the 37<sup>th</sup> Intersociety Energy Conversion Engineering Conference*, Washington, D.C., IECEC 2002 Paper No. 20121, (2002a).
- Ibrahim, M.B., Zhang, Z., Kembhavi, S., Simon, T.W., Tew, R. and Gedeon, D., "A Model of 90 Degree Turn Oscillatory Flow," *Proceedings of the 1st International Energy Conversion Engineering Conference*, Portsmouth, VA, Paper No. AIAA-2003-5935, (2003a).
- Ibrahim, M.B., Rong, W., Simon, T.W., Tew, R. and Gedeon, D., "Microscopic Modeling of Unsteady Convective Heat Transfer in a Stirling Regenerator Matrix," *Proceedings of the 1st International Energy Conversion Engineering Conference*, Portsmouth, VA, Paper No. AIAA-2003-6016, (2003b).
- Kornhauser, A.A., *Gas-Wall Heat Transfer During Compression and Expansion*, Massachusetts Institute of Technology, S.D. Thesis, 1989.
- Tew, R.C., Cairelli, J.E., Ibrahim, M.B., Simon, T.W., and Gedeon, D., "Overview of NASA Multi-Dimensional Stirling Converter Code Development and Validation Effort," in *Proceedings of the Space Technology Applications International Forum (STAI-2003)*, Albuquerque, NM, edited by M.S. El-Genk, American Institute of Physics, Melville, NY, 2003, AIP CP-654, pp. 668-676, also as NASA/TM-2002-211997, 2002.
- Thieme, L.G., and Schreiber, J.G., "NASA GRC Stirling Technology Overview," *Proceedings of the Space Technology Applications International Forum (STAI-2003)*, Albuquerque, NM, edited by M.S. El-Genk, American Institute of Physics, Melville, NY, 2003, AIP CP-654, pp. 613-620, also as NASA/TM-2003-212454, 2003.
- Niu, Y., Simon, T.W., Ibrahim, M.B., and Gedeon, D., "Oscillatory Flow and Thermal Field Measurements at the Interface between a Heat Exchanger and a Regenerator of a Stirling Engine," *Proceedings of the 37<sup>th</sup> Intersociety Energy Conversion Engineering Conference*, Washington, D.C., IECEC 2002 Paper No. 20141, (2002).
- Niu, Y., Simon, T.W., Ibrahim, M.B., and Gedeon, D., "Thermal Dispersion of Discrete Jets upon Entrance to a Stirling Engine Regenerator under Oscillatory Flow Conditions," *Proceedings of the 6<sup>th</sup> ASME-JSME Thermal Engineering Joint Conference*, Hapuna Beach, Hawaii Island, Hawaii, TED-AJ03-641, (2003a).
- Niu, Y., Simon, T.W., Ibrahim, M.B., Tew, R., and Gedeon, D., "Measurements of Unsteady Convective Heat Transfer Rates within a Stirling Regenerator Matrix Subjected to Oscillatory Flow," *Proceedings of the 1st International Energy Conversion Engineering Conference*, Portsmouth, VA, Paper No. AIAA-2003-6013, (2003b).
- Niu, Y., Simon, T.W., Ibrahim, M.B., Tew, R., and Gedeon, D., "JET Penetration into a Stirling Engine Regenerator Matrix with Various Regenerator-to-Cooler Spacings," *Proceedings of the 1st International Energy Conversion Engineering Conference*, Portsmouth, VA, Paper No. AIAA-2003-6014, (2003c).
- Qiu, S. and Simon, T.W., "Measurements of Heat Transfer and Fluid Mechanics within an Oscillatory Flow in a Pipe," *Fundamentals of Heat Transfer in Forced Convection*, ASME HTD-Vol. 285, pp. 1-8. F.W. Schmidt and R.J. Moffat, Winter Annual Meeting, Chicago, IL, 1994.

# REPORT DOCUMENTATION PAGE

Form Approved  
OMB No. 0704-0188

Public reporting burden for this collection of information is estimated to average 1 hour per response, including the time for reviewing instructions, searching existing data sources, gathering and maintaining the data needed, and completing and reviewing the collection of information. Send comments regarding this burden estimate or any other aspect of this collection of information, including suggestions for reducing this burden, to Washington Headquarters Services, Directorate for Information Operations and Reports, 1215 Jefferson Davis Highway, Suite 1204, Arlington, VA 22202-4302, and to the Office of Management and Budget, Paperwork Reduction Project (0704-0188), Washington, DC 20503.

<b>1. AGENCY USE ONLY (Leave blank)</b>	<b>2. REPORT DATE</b> January 2004	<b>3. REPORT TYPE AND DATES COVERED</b> Technical Memorandum	
<b>4. TITLE AND SUBTITLE</b> Overview 2003 of NASA Multi-D Stirling Converter Code Development and DOE and NASA Stirling Regenerator R&D Efforts		<b>5. FUNDING NUMBERS</b>  WBS-22-755-60-16 WBS-22-972-30-02	
<b>6. AUTHOR(S)</b> Roy Tew, Mounir Ibrahim, Terry Simon, Susan Mantell, David Gedeon, Songgang Qiu, and Gary Wood		<b>8. PERFORMING ORGANIZATION REPORT NUMBER</b>  E-14330	
<b>7. PERFORMING ORGANIZATION NAME(S) AND ADDRESS(ES)</b> National Aeronautics and Space Administration John H. Glenn Research Center at Lewis Field Cleveland, Ohio 44135-3191		<b>10. SPONSORING/MONITORING AGENCY REPORT NUMBER</b>  NASA TM-2004-212908	
<b>9. SPONSORING/MONITORING AGENCY NAME(S) AND ADDRESS(ES)</b> National Aeronautics and Space Administration Washington, DC 20546-0001		<b>11. SUPPLEMENTARY NOTES</b> Prepared for the Space Technology and Applications International Forum (STAIF-2004) sponsored by the American Institute of Physics, Albuquerque, New Mexico, February 8-12, 2004. Roy Tew, NASA Glenn Research Center; Mounir Ibrahim, Cleveland State University, Cleveland, Ohio 44115; Terry Simon and Susan Mantell, University of Minnesota, Minneapolis, Minnesota 55455; David Gedeon, Gedeon Associates, Athens, Ohio 45701; Songgang Qiu, Stirling Technology Company, Kennewick, Washington 99336; and Gary Wood, Sunpower Inc., Athens, Ohio 45701. Responsible person, Roy Tew, organization code 5490, 216-433-8471.	
<b>12a. DISTRIBUTION/AVAILABILITY STATEMENT</b> Unclassified - Unlimited Subject Category: 20  Available electronically at <a href="http://gltrs.grc.nasa.gov">http://gltrs.grc.nasa.gov</a> This publication is available from the NASA Center for AeroSpace Information, 301-621-0390.		<b>12b. DISTRIBUTION CODE</b>	
<b>13. ABSTRACT (Maximum 200 words)</b>  This paper will report on continuation through the third year of a NASA grant for multi-dimensional Stirling CFD code development and validation; continuation through the third and final year of a Department of Energy, Golden Field Office (DOE), regenerator research effort and a NASA grant for continuation of the effort through two additional years; and a new NASA Research Award for design, microfabrication and testing of a "Next Generation Stirling Engine Regenerator." Cleveland State University (CSU) is the lead organization for all three efforts, with the University of Minnesota (UMN) and Gedeon Associates as subcontractors. The Stirling Technology Company and Sunpower, Inc. acted as unfunded consultants or participants through the third years of both the NASA multi-D code development and DOE regenerator research efforts; they will both be subcontractors on the new regenerator microfabrication contract.			
<b>14. SUBJECT TERMS</b> Stirling engines; Computerized simulation; Unsteady flow; Convective heat transfer; Regenerators			<b>15. NUMBER OF PAGES</b> 16
<b>17. SECURITY CLASSIFICATION OF REPORT</b> Unclassified			<b>16. PRICE CODE</b>
<b>18. SECURITY CLASSIFICATION OF THIS PAGE</b> Unclassified	<b>19. SECURITY CLASSIFICATION OF ABSTRACT</b> Unclassified	<b>20. LIMITATION OF ABSTRACT</b>	