

NASA/TM—2005-212624/PART2



# Vibration Based Crack Detection in a Rotating Disk

## Part 2—Experimental Results

Andrew L. Gyekenyesi  
Ohio Aerospace Institute, Brook Park, Ohio

Jerzy T. Sawicki and Richard E. Martin  
Cleveland State University, Cleveland, Ohio

Wayne C. Haase  
Aerogage, Inc., Sterling, Massachusetts

George Baaklini  
Glenn Research Center, Cleveland, Ohio

## The NASA STI Program Office . . . in Profile

Since its founding, NASA has been dedicated to the advancement of aeronautics and space science. The NASA Scientific and Technical Information (STI) Program Office plays a key part in helping NASA maintain this important role.

The NASA STI Program Office is operated by Langley Research Center, the Lead Center for NASA's scientific and technical information. The NASA STI Program Office provides access to the NASA STI Database, the largest collection of aeronautical and space science STI in the world. The Program Office is also NASA's institutional mechanism for disseminating the results of its research and development activities. These results are published by NASA in the NASA STI Report Series, which includes the following report types:

- **TECHNICAL PUBLICATION.** Reports of completed research or a major significant phase of research that present the results of NASA programs and include extensive data or theoretical analysis. Includes compilations of significant scientific and technical data and information deemed to be of continuing reference value. NASA's counterpart of peer-reviewed formal professional papers but has less stringent limitations on manuscript length and extent of graphic presentations.
- **TECHNICAL MEMORANDUM.** Scientific and technical findings that are preliminary or of specialized interest, e.g., quick release reports, working papers, and bibliographies that contain minimal annotation. Does not contain extensive analysis.
- **CONTRACTOR REPORT.** Scientific and technical findings by NASA-sponsored contractors and grantees.

- **CONFERENCE PUBLICATION.** Collected papers from scientific and technical conferences, symposia, seminars, or other meetings sponsored or cosponsored by NASA.
- **SPECIAL PUBLICATION.** Scientific, technical, or historical information from NASA programs, projects, and missions, often concerned with subjects having substantial public interest.
- **TECHNICAL TRANSLATION.** English-language translations of foreign scientific and technical material pertinent to NASA's mission.

Specialized services that complement the STI Program Office's diverse offerings include creating custom thesauri, building customized databases, organizing and publishing research results . . . even providing videos.

For more information about the NASA STI Program Office, see the following:

- Access the NASA STI Program Home Page at <http://www.sti.nasa.gov>
- E-mail your question via the Internet to [help@sti.nasa.gov](mailto:help@sti.nasa.gov)
- Fax your question to the NASA Access Help Desk at 301-621-0134
- Telephone the NASA Access Help Desk at 301-621-0390
- Write to:  
NASA Access Help Desk  
NASA Center for AeroSpace Information  
7121 Standard Drive  
Hanover, MD 21076



# Vibration Based Crack Detection in a Rotating Disk

## Part 2—Experimental Results

Andrew L. Gyekenyesi  
Ohio Aerospace Institute, Brook Park, Ohio

Jerzy T. Sawicki and Richard E. Martin  
Cleveland State University, Cleveland, Ohio

Wayne C. Haase  
Aerogage, Inc., Sterling, Massachusetts

George Baaklini  
Glenn Research Center, Cleveland, Ohio

National Aeronautics and  
Space Administration

Glenn Research Center

This report contains preliminary findings, subject to revision as analysis proceeds.

Available from

NASA Center for Aerospace Information  
7121 Standard Drive  
Hanover, MD 21076

National Technical Information Service  
5285 Port Royal Road  
Springfield, VA 22100

Available electronically at <http://gltrs.grc.nasa.gov>



# Vibration Based Crack Detection in a Rotating Disk

## Part 2—Experimental Results

Andrew L. Gyekenyesi  
Ohio Aerospace Institute  
Brook Park, Ohio 44142

Jerzy T. Sawicki and Richard E. Martin  
Cleveland State University  
Cleveland, Ohio 44115

Wayne C. Haase  
Aerogage, Inc.  
Sterling, Massachusetts 01564

George Y. Baaklini  
National Aeronautics and Space Administration  
Glenn Research Center  
Cleveland, Ohio 44135

### Abstract

This paper describes the experimental results concerning the detection of a crack in a rotating disk. The goal was to utilize blade tip clearance and shaft vibration measurements to monitor changes in the system's center of mass and/or blade deformation behaviors. The concept of the approach is based on the fact that the development of a disk crack results in a distorted strain field within the component. As a result, a minute deformation in the disk's geometry as well as a change in the system's center of mass occurs. Here, a notch was used to simulate an actual crack. The vibration based experimental results failed to identify the existence of a notch when utilizing the approach described above, even with a rather large, circumferential notch (1.2 in.) located approximately mid-span on the disk (disk radius = 4.63 in. with notch at  $r = 2.12$  in.). This was somewhat expected, since the finite element based results in Part 1 of this study predicted changes in blade tip clearance as well as center of mass shifts due to a notch to be less than 0.001 in. Therefore, the small changes incurred by the notch could not be differentiated from the mechanical and electrical noise of the rotor system. Although the crack detection technique of interest failed to identify the existence of the notch, the vibration data produced and captured here will be utilized in upcoming studies that will focus on different data mining techniques concerning damage detection in a disk.

### Introduction

Researchers at the NASA Glenn Research Center are currently assessing the feasibility of utilizing real-time vibration data for detecting cracks in turbine disks. For this study, the data is obtained either from radial blade tip clearance and/or shaft vibration measurements using capacitive or eddy current displacement probes. The concept of the particular approach addressed here is based on the fact that the development of a disk crack results in a distorted strain field within the component. This, in turn, causes a small deformation in the disk's geometry as well as a possible change in the system's center of mass. The geometric change and the center of mass shift can be indirectly characterized by monitoring the amplitude and phase of the first harmonic (i.e., the 1x component) of the vibration data. Spin pit experiments, full scale engine tests, as well as analytical studies have been documented regarding the above crack detection methodology (refs. 1 to 4), although, none of them presented a well controlled test program with a known



damage state. In addition, the few tests that claimed success have been limited mostly to the spin pit facilities. In spin pits, a vertical, hanging shaft is utilized with only the top having a bearing support. The disk or disks of interest are usually located near the bottom end of the shaft. Because the bottom end of the shaft is unconstrained, it is relatively free to move as a result of any dynamic forces. Therefore, it is assumed that any physical changes in the rotor will induce larger displacement variations in a spin pit set-up than in a more constrained, two bearing system. The experiments conducted here deal with a horizontal shaft supported with end bearings and a centrally located disk. It should be noted that this type of system is somewhat unique in the arena of spin testing due to the fact that the horizontal shaft is supported by bearings on both ends of the rotor. This is a more realistic representation of an actual turbine as compared to a traditional spin pit configuration.

In Part 1 of this report (ref. 5), finite element (FE) analyses were conducted in order to predict the geometric deformations and the associated shift of the center of mass as a function of multiple notch sizes and rotational speeds. Note that notches were used to simulate cracks. The results of the FE analyses of the disk indicated that the overall changes in the disk's geometry and the center of mass were rather small. As an example, the calculated difference between the maximum radial displacements (i.e., at the blade tip) due to centrifugal expansion between the undamaged and damaged disks at 8000 rpm was 0.00014 in. for a 0.963 in. notch length. The shift in center of mass was also of this magnitude.

The objectives of this study included conducting rotor experiments on a disk in an undamaged state as well as a notched state in order to assess the damage detecting capability of the approach described above, i.e., monitoring the shift in the center of mass and/or changes in the disk geometry due to the damage. The experimental set-up was based on the analytical results of Part 1 (ref. 5). This included the disk design as well as the parameters for the rotor test system. In addition, the blade tip measurements were achieved utilizing a unique and innovative capacitive sensor along with the accompanying acquisition/analysis software package, while the shaft displacement measurements were obtained using a commercially available system based on non-contacting eddy current displacement probes.

## Experimental Facilities and Procedure

Figure 1 shows the experimental facilities utilized for this study. The system has an adjustable shaft length, and thus, allows one to select an appropriate length to assure operation beyond the system's first critical speed. Here, the maximum length was used based on the rotordynamic calculations of reference 5 that indicated a critical speed of 2610 revolutions per minute (rpm). The stainless steel shaft length and diameter were 30.75 and 0.79 in., respectively. The shaft was supported by precision angular contact ball bearings that were assumed to provide isotropic stiffness. The single disk, as seen in figure 1, was mounted at the mid-span of the shaft. Figure 2 shows a schematic of the disk. The nickel disk was designed to safely handle rotational speeds up to 25000 rpm in the undamaged state. A thinned web area and gear teeth were implemented to imitate the web area and blades of a turbine disk. Note that the gear teeth were also needed due to the fact that the capacitive displacement sensors utilized during experimentation were specially designed, both concerning the hardware and the analysis software, to monitor radial blade tip clearances. The nickel alloy, Haynes X-750, was the material used for the disk. The disk's final design had an outside diameter of 9.25 in. and a bore thickness and outside rim thickness of 1.00 and 1.25 in., respectively. The thinnest portion of the web was 0.10 in., with the cross-section and height dimensions of the blades being 1.25 by 0.13 in. and 0.33 in., respectively. The weight of the disk was 10.75 lbf. Lastly, eight holes, 0.20 in. diameter each, were placed midway in the rim section. The eight holes were spaced every 45 degrees. The holes were designed for future studies as possible mass attachment points or notch initiation sites.

Displacement data were captured utilizing two types of non-contact sensors. For blade tip clearance measurements, a capacitive sensor system was employed. The innovative capacitive sensors were based on a DC offset rather than using a modulation technique. The DC voltage, in conjunction with the motion of the rotor, allowed the current system to capture three channels of data at bandwidths up to 10 MHz each. During this study, data was captured at a rate of 1 MHz. Upon acquisition, the data was analyzed



using unique, in-house software. The second sensor system, based on eddy current displacement probes, was utilized to capture shaft vibrations. The data was analyzed with the accompanying software package that was part of the commercially available system.

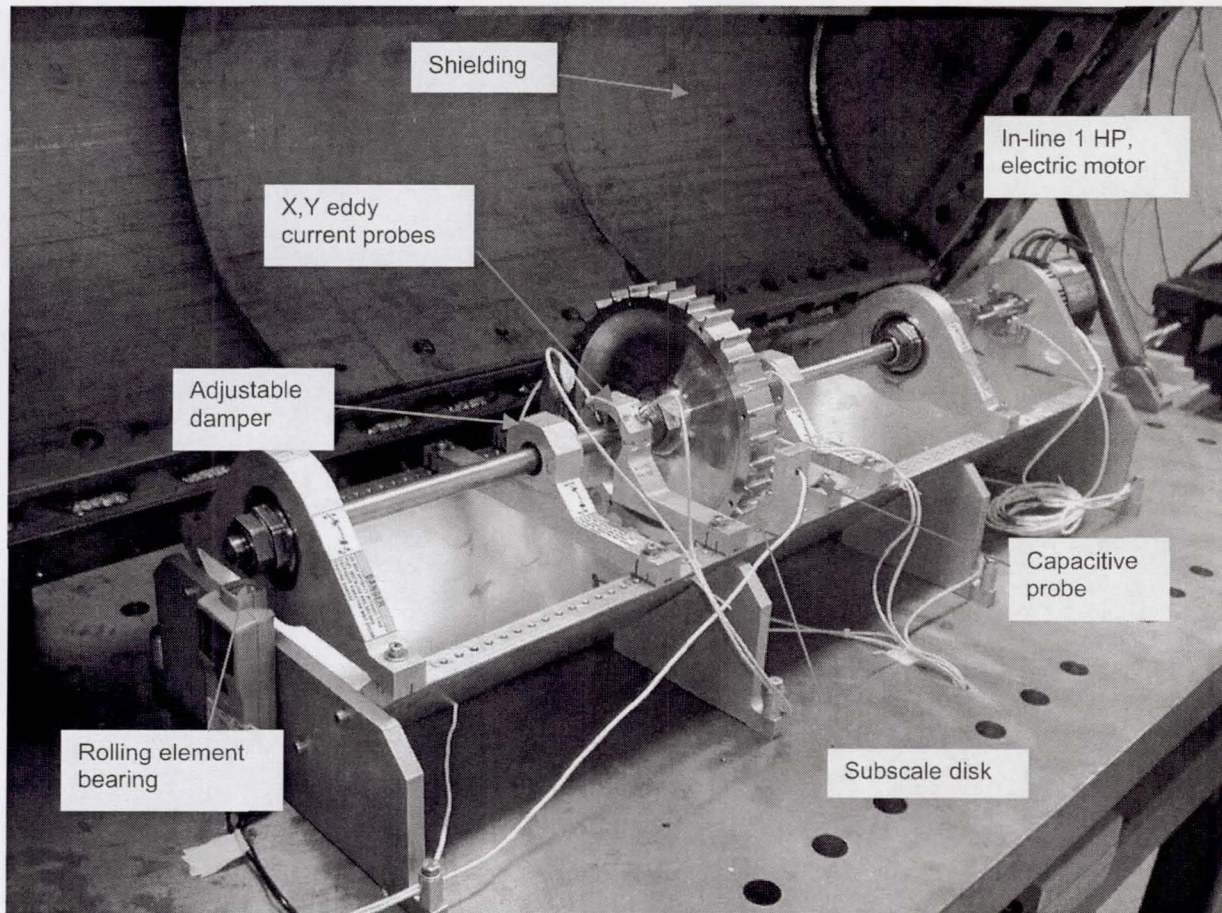

Figure 1.—Rotordynamic test stand.

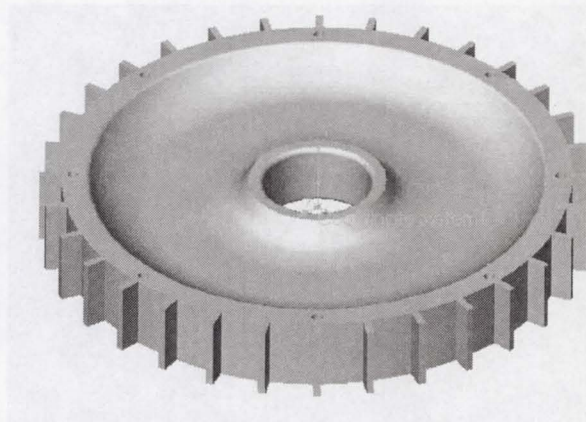

Figure 2.—Schematic of subscale disk.



The experimental procedure involved conducting five repetitions of spin-up/spin-down tests with an undamaged disk, followed by five repetitions with a damaged disk (i.e., notched). During the tests blade tip clearance data and shaft vibration data were continuously recorded. The maximum rotational speeds attained were between 5000 and 5400 rpm with acceleration/deceleration rates of 60 rpm/second. Note that the maximum speed was beyond the calculated critical speed of 2610 rpm, thereby guaranteeing post-critical operation. Following the baseline experiments, the disk was removed from the test stand and a 1.2 in. circumferential notch was induced approximately mid-span in the web area using electric discharge machining (EDM). This area was chosen because it had the largest stresses based on the finite element analysis of Part 1 (ref. 5). The notch had a width of 0.015 in. due to the wire thickness and burn area of the EDM process. Careful consideration was given during reassembly so as to maintain the baseline conditions for all system parameters, except of course, for the notch. Various views of the notched disk are shown in figures 3 and 4.

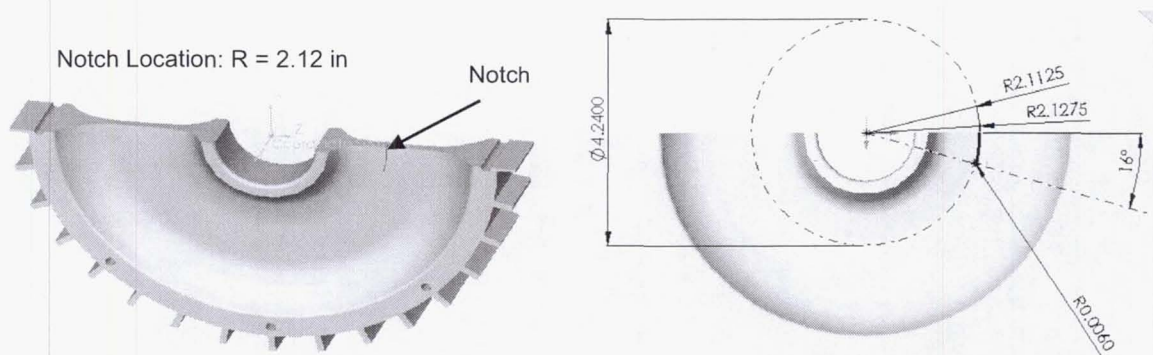

Figure 3.—Schematic showing 1.2 in. circumferential length notch.

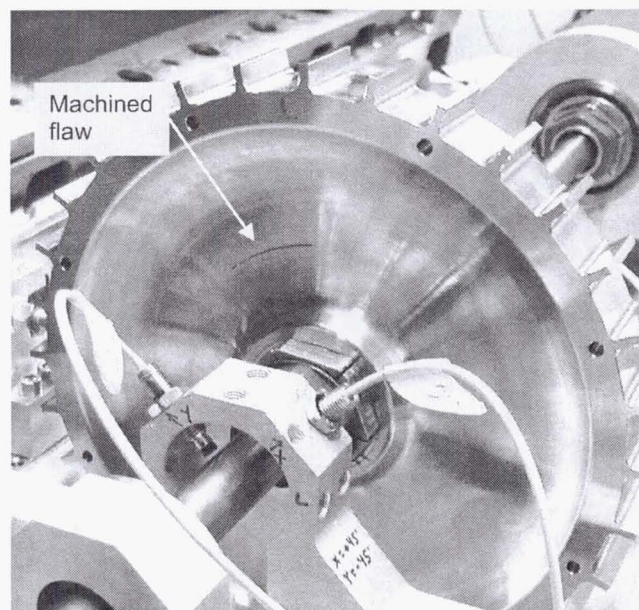

Figure 4.—Image of notched disk



## Results

Typical results for the un-notched, baseline case are shown in figures 5 and 6. Figure 5 displays an image of the capacitive probe system's post processing software, while figure 6 represents results from the eddy current probe system. As mentioned in the introduction, shifts in the center of mass are tracked by monitoring the 1-x component of the vibration response. The 1-x component, or first harmonic response, follows the amplitude and phase lag of the synchronous whirl of the rotor system. Changes in the center of mass induce changes in the amplitude and/or phase of the 1-x component. The synchronous whirl behaviors are usually displayed as Bode plots where the amplitude and phase of the system are plotted as functions of rotational frequency. These plots are indicated in figures 5 and 6. Individual blade tip clearance values at multiple rpms are shown in figure 7, again, for a typical baseline test. For the un-notched baseline condition, the rotor's critical speed and the associated maximum amplitude, calculated using the blade tip displacements, were 2614 rpm (standard deviation = 96 rpm) and 0.0021 in. (standard deviation = 0.00011 in.), respectively. Utilizing the eddy current probe data the average critical speed and maximum amplitude were 2332 rpm (standard deviation = 36 rpm) and 0.0031 in. (standard deviation = 0.00021 in.), respectively. The discrepancy between the two sensor systems was probably due to the differences in calculation methodologies, although, the capacitive system's values agreed well with the calculated results (2610 rpm) of Part 1 (ref. 5).

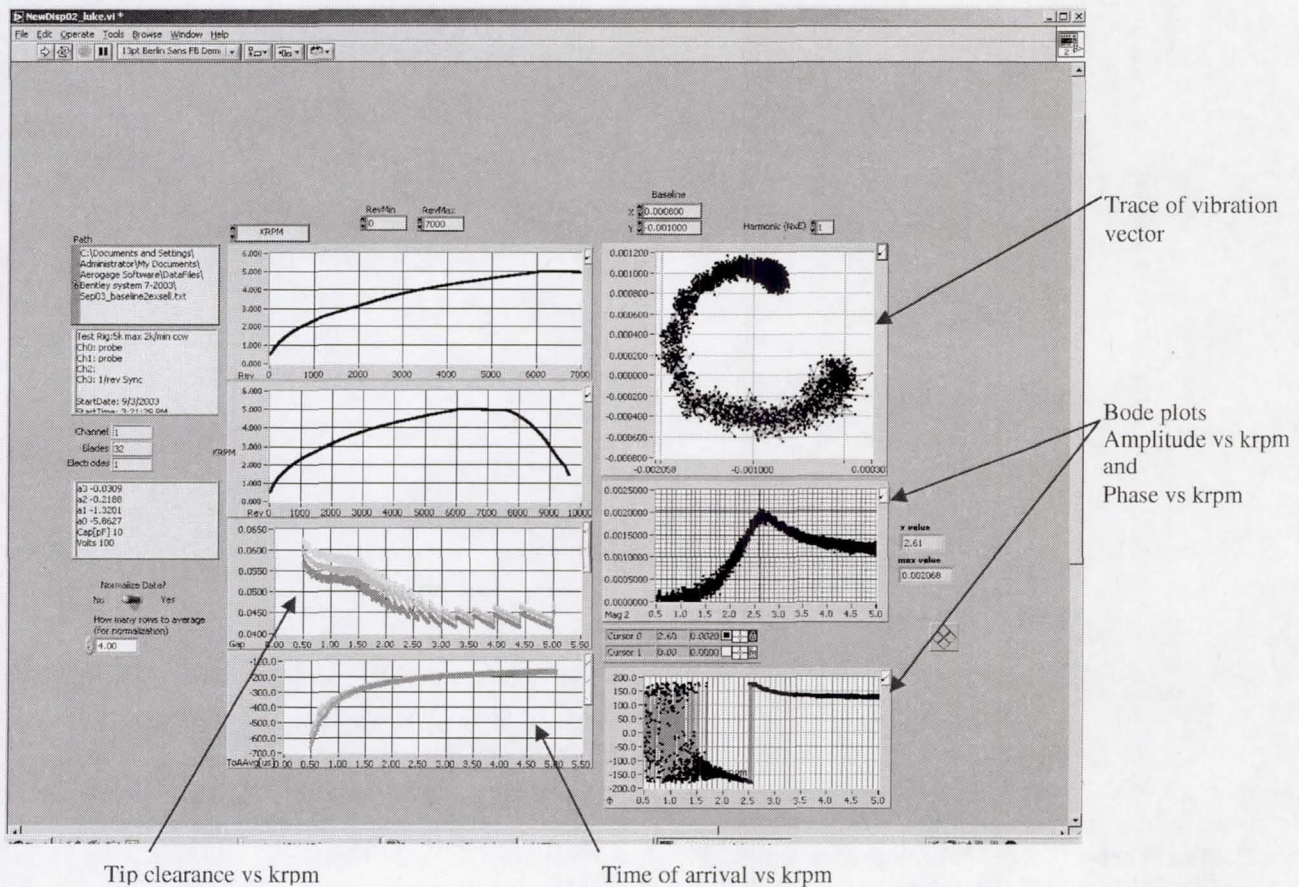

Figure 5.—Typical blade tip clearance data displayed using software associated with the capacitive sensors for the undamaged, baseline disk.



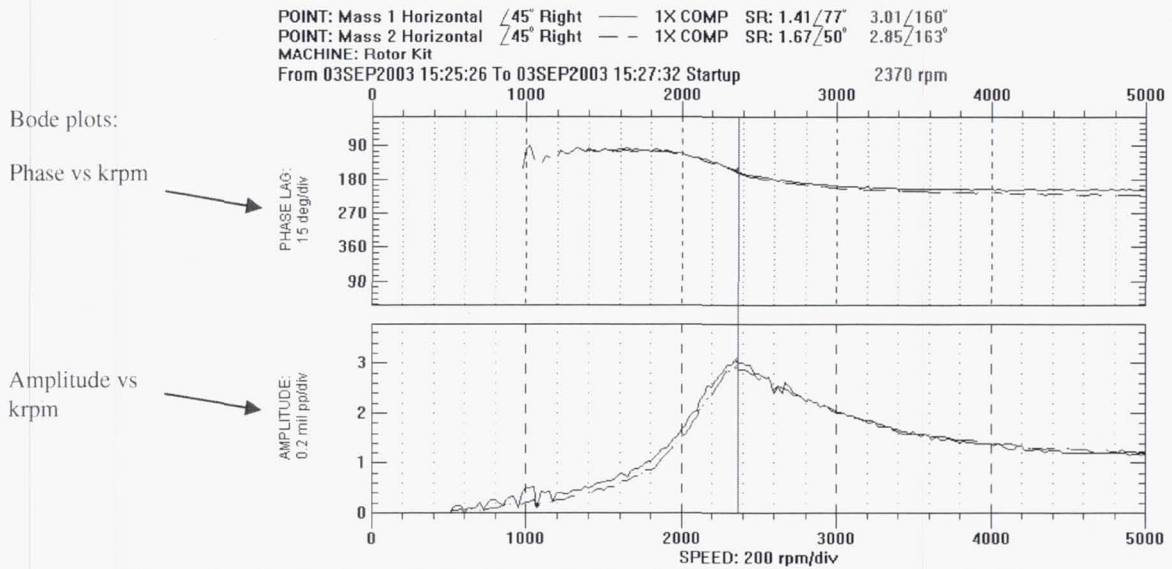

Figure 6.—Bode plots of vibrations displayed using software associated with the eddy current sensor system for the undamaged, baseline disk.

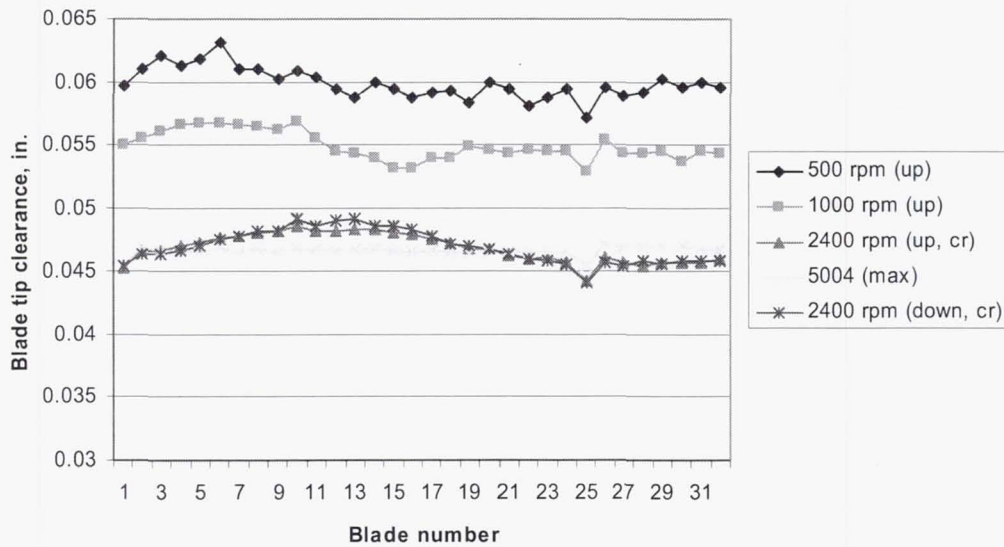

Figure 7.—Blade tip clearance values as a function of rotational speed for a typical baseline test.

After the introduction of a notch in the disk's web area, the system was carefully reassembled. Typical results for the notched disk are shown in figures 8 through 10. One notable observation included an increase in the noise level concerning the capacitive probe system. This was apparent in the Bode plots as well as the trace of the vibration vector as seen in figure 8. One explanation involved possible mechanical changes in the overall system induced during reassembly. These mechanical changes were indicated by the modifications in the critical speeds and associated maximum amplitudes of whirl as measured by the two sensor systems. The critical speeds and amplitudes of whirl for the system after reassembly were 2658 rpm (standard deviation = 331 rpm) and 0.0018 in. (0.00059 in.) for the blade tip clearance sensor system and 2448 rpm (standard deviation = 61 rpm) and 0.0060 in. (standard deviation = 0.00028 in.) for the eddy current system that was used to monitor the shaft vibrations. Noteworthy were



the increased standard deviations regarding all the values as well as a statistically significant 5 percent increase in the critical speed as measured by the eddy current system. Another noise related observation after reassembly was an apparent choppiness of the blade displacement data in figure 10, especially for rotational speeds below 1000 rpm. Above this speed, the measurements regulated and looked very similar to the baseline tests. Note that in order to obtain better signals regarding the capacitive probe system, the sensors were moved closer for the notched disk tests (compare the offset values in figures 7 and 10). Lastly, during the time frame of the experiments it was discovered that the capacitive probes were sensitive to moisture absorption due to the humidity in the laboratory. As a result, the probes needed to be dried in a low temperature oven and recalibrated prior to each test.

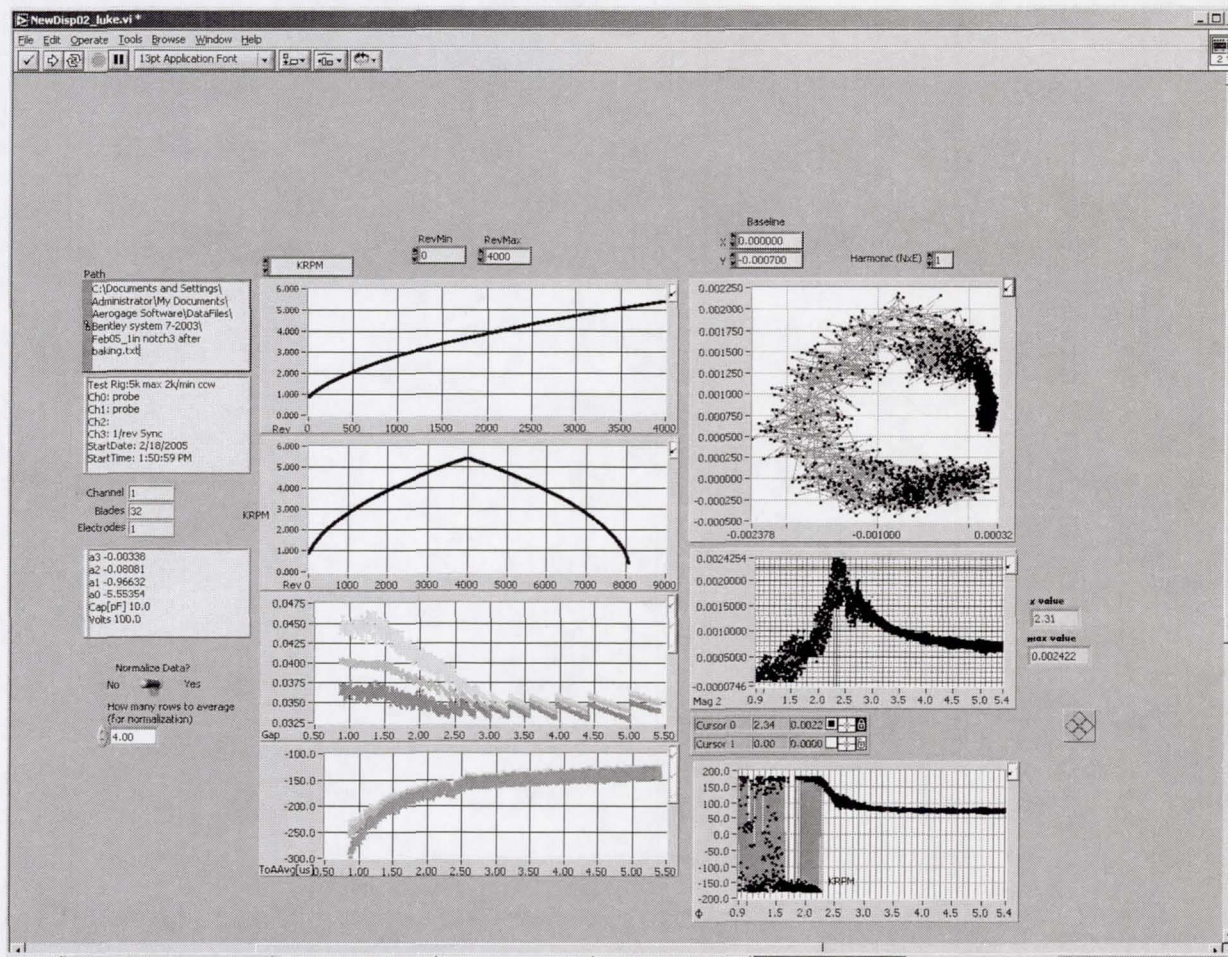

Figure 8.—Typical blade tip clearance data displayed using software associated with the capacitive sensors for the notched disk.

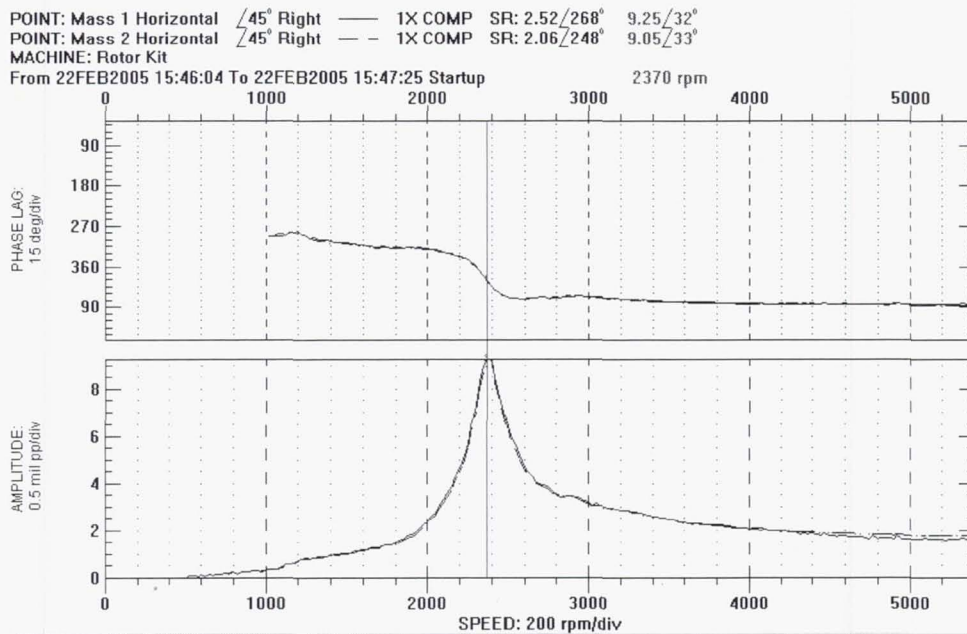

Figure 9.—Bode plots of shaft vibrations displayed using software associated with the eddy current sensor system for the notched disk.

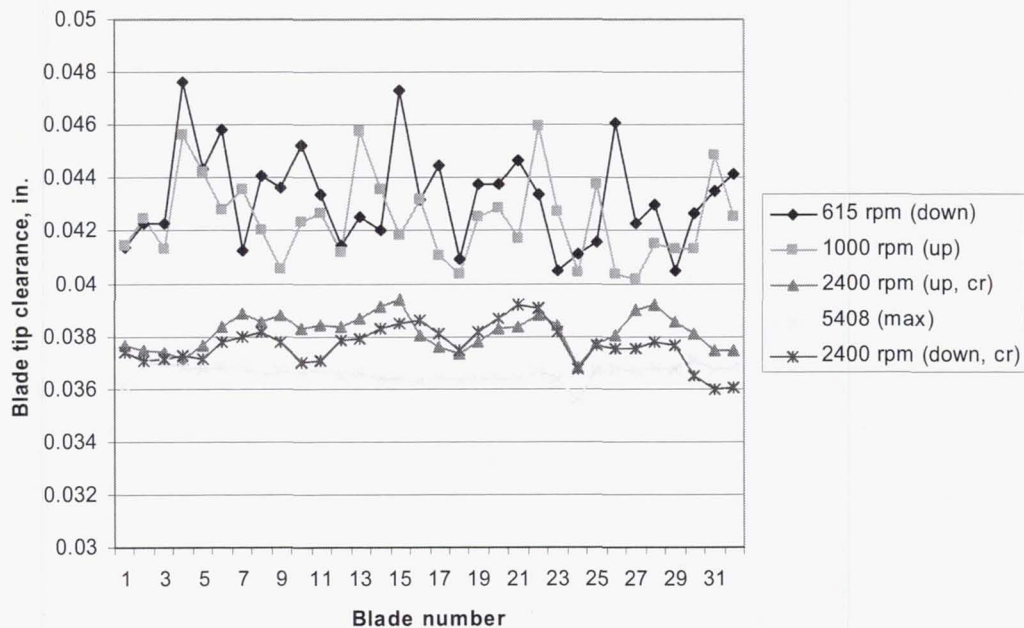

Figure 10.—Blade tip clearance values as a function of rotational speed for a typical notched test.

## Discussion of Results

The experimental set-up employed here is assumed to behave like a 2-degree of freedom Jeffcott rotor (ref. 6). In such a system, the lateral vibrations are mainly due to the bending of a flexible shaft. The amplitude of the first harmonic, which represents the deformation of the shaft (e.g., see the Bode plots in



figs. 5 through 10) or rotor response, increases as a function of speed until the critical speed is achieved at which point the amplitude is at its maximum and a 180 degree phase inversion occurs. After the critical speed the system's 1-x amplitude decreases to a level equal to the system's eccentricity and then maintains a constant value even with increasing speed. Note that the eccentricity vector defines the location of the system's center of mass. The maintenance of constant amplitude occurs due to the fact that the rotor now rotates about the system's center of mass. Furthermore, an ideal Jeffcott rotor system defines the eccentricity vector as a fixed constant regardless of rotational speed. For the center of mass based damage detection approach studied here, a crack is assumed to open up as the centrifugal forces increase with speed. Therefore, the shifting of mass as the notch opens causes the eccentricity of the system to change with speed. Figure 11 shows an exaggerated representation of the effects of damage, and the associated speed dependent eccentricity, in the post critical speed domain for the current system.

In Part 1 (ref. 5), FE based analyses defined the change in center of mass (i.e., a change with respect to an initial undamaged value) for the disk as a function of notch size and speed. Figure 12 shows the analysis results for the particular 1.2 in. notch employed here. The change in amplitude as a function of frequency was shown to be a second order polynomial as indicated in the figure (units: in. and rpm). Note that the coefficient values were very small and difficult to measure experimentally. Furthermore, at this point no effort was made to define the disk's initial eccentricity vector (amplitude and phase), hence, the values of the particular coefficients describing the shift/change in the center of mass were values observable only if the changes due to the notch were in-phase with the disk's eccentricity vector (causing increasing amplitude). The coefficients would be different if the phase difference between the initial eccentricity vector and the change vector was something other than zero degrees. Therefore, the approach taken here was to analyze the post critical 1-x amplitude behavior regarding the experimental data and search for a statistically significant coefficient for the  $\omega^2$  term that would only be present due to a speed dependent eccentricity vector resulting from a notch. Because the blade tip clearance system utilized modifiable, in-house software, data was easily exported for further analysis of the post critical amplitude behavior. This was not the case for the eddy current measurement system used to monitor the shaft vibrations.

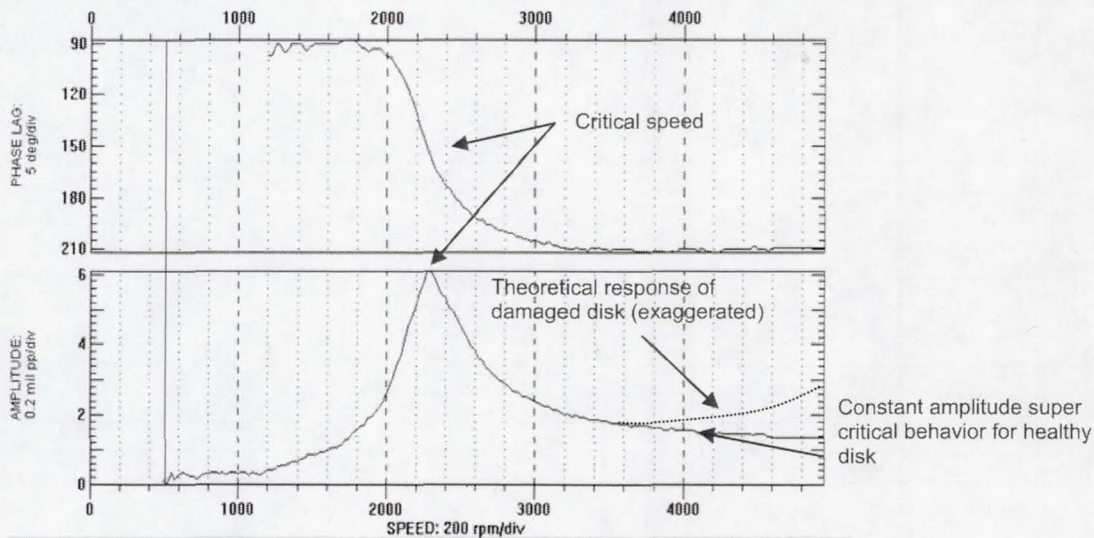

Figure 11.—Exaggerated view of post critical 1-x amplitude behavior (dotted line) of a damaged disk system.

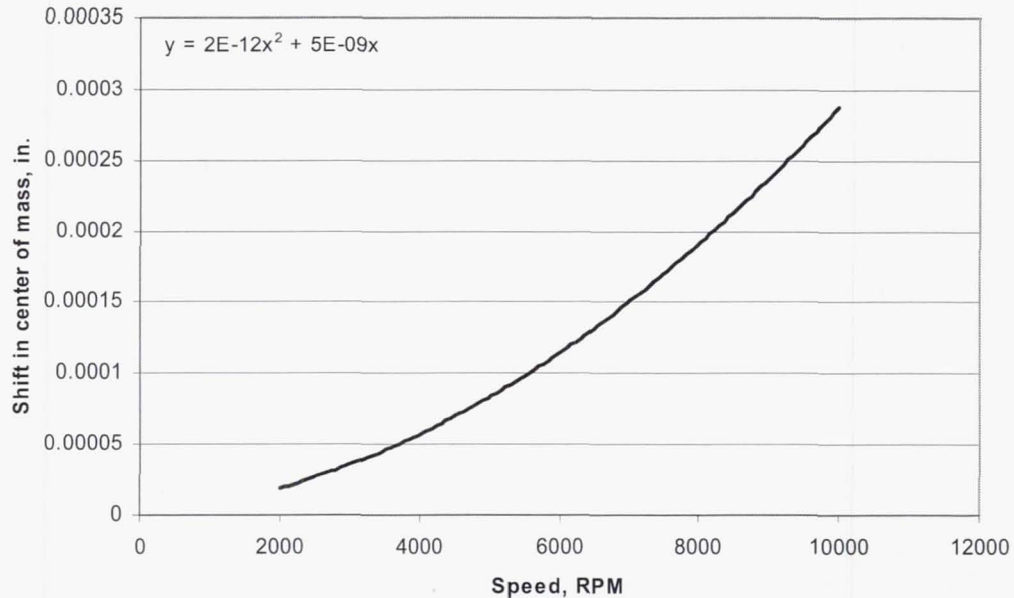

Figure 12.—Finite element analysis results defining amplitude change of the eccentricity vector due to speed dependent opening of a circumferential notch in the web area of the disk (1.2 in. notch). The second order polynomial curve fit of the finite element based results are indicated on the plot.

After extracting the post critical 1-x amplitude data from the blade tip clearance measurements (see figs. 5 and 8) for both the baseline and notch tests, a second order polynomial curve fit was conducted using the data. In addition, the statistical significance of the coefficients was calculated. The values of the coefficients as well as their associated statistical significance as represented by the t-values (ref. 7) are shown in table 1. Note that the frequency range of the exported data was 4500 rpm to the maximum speed (between 4900 and 5400 rpm).

TABLE 1.—PARAMETER VALUES FOR SECOND ORDER POLYNOMIAL FIT OF POST CRITICAL EXPERIMENTAL DATA

Test ID	Intercept	t-value	x-coefficient	t-value	x <sup>2</sup> -coefficient	t-value
Baseline 1	9.37E-04	0.665	2.21E-07	0.372	-3.40E-11	0.551
Baseline 2	-5.67E-04	0.185	8.41E-07	0.668	-9.80E-11	0.758
Baseline 3	-1.23E-02	1.82	5.60E-06	2.035	-5.80E-10	2.08
Baseline 4	5.87E-04	0.167	3.81E-07	0.264	-5.30E-11	0.357
Baseline 5	-1.62E-02	1.59	7.25E-06	1.77	-7.50E-10	1.82
Notch 1	-5.40E-04	1.21	3.29E-07	1.76	-3.30E-11	1.69
Notch 2	2.07E-03	1.84	-4.50E-07	1.01	3.63E-11	0.827
Notch 3	1.43E-03	0.610	-2.00E-07	0.221	1.21E-11	0.138
Notch 4	5.41E-03	1.50	-1.80E-06	1.26	1.60E-10	1.19
Notch 5	2.85E-03	1.28	-7.90E-07	0.918	6.71E-11	0.809

There was no recognizable pattern in the experimentally derived parameters for the second order curve fit based on the data in table 1. Some intercept and slope coefficients values were positive while others were negative. Note that in most cases the values were not significantly different from zero as indicated by the low t-values. Better results may have been produced if the system could have achieved greater speeds. With an increasing speed there would be a minimizing of the critical speed influence (i.e.,



achieving the true flat portion of the curve away from the critical peak) and at the same time the disk would be further deformed causing a greater shift in the center of mass. Note that the maximum speeds were limited by the motor's rating as well as the FE analysis regarding the notch tip yield stress. In the end, the experimental data showed that the center of mass approach for damage detection did not indicate the presence of the rather large notch, at least for the experimental set-up employed here.

Next, comparisons of blade displacement behaviors between the baseline and notched cases were conducted as seen in figures 13 and 14. Multiple data sets were grouped together in an effort to see any unusual deformation behavior in the vicinity of the notch. Note that the notch was circumferentially located in the vicinity of blades 25 through 28 as indicated in figures 13 and 14. Typical subtraction results (= baseline – notch) are shown in figure 14. No obvious patterns were seen in either plot that indicates additional extensions of the affected blades (i.e., blades 25 through 28).

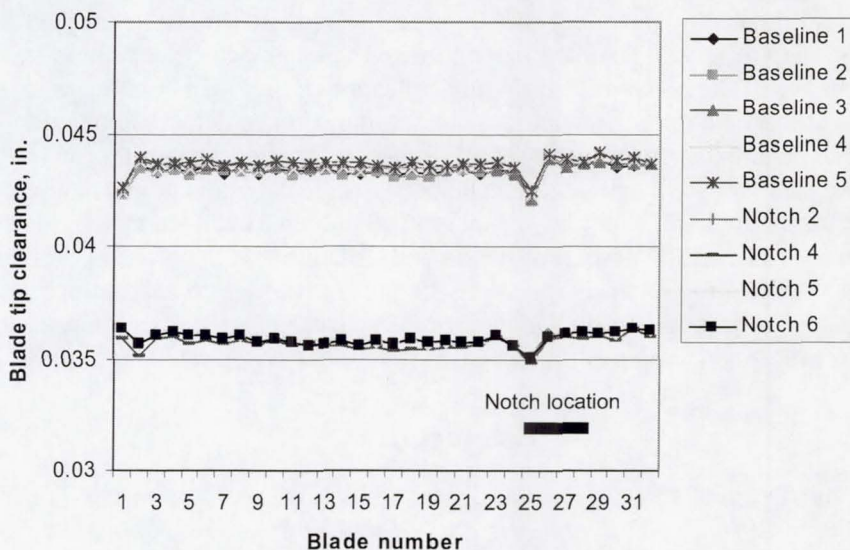

Figure 13.—Comparison of blade tip clearance values at 4900 rpm. The notch location is indicated in the plot.

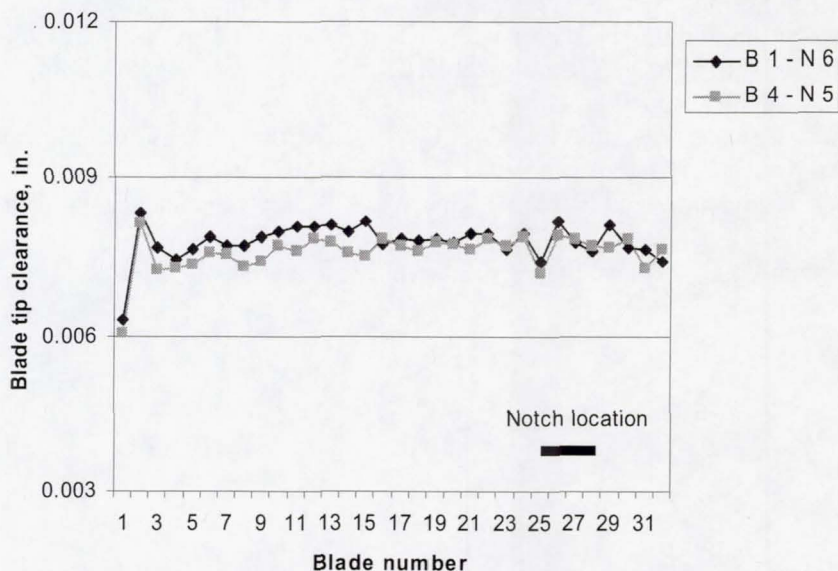

Figure 14.—Typical results regarding the subtraction of notch test results from baseline results at 4900 rpm.

## Conclusions and Future Direction

This report in conjunction with Part 1 (ref. 5) addressed the feasibility of utilizing vibration based data as a tool for recognizing disk damage prior to catastrophic failure. The particular concept used here focused on measuring deformations in the disk's geometry and the corresponding change in the system's center of mass. The amplitude and phase of the first harmonic (i.e., the 1x component) of the vibration data was monitored as well as the blade deformation behavior. The experimental data included both blade tip clearances as well as shaft vibrations near the disk. The numerical results of Part 1 showed that the expected changes in the disk geometry and system's center of mass were rather small and probably close to the resolution limits of the non-contact displacement sensors used during the experiments. In the end, the experimental data revealed that the vibration based techniques used here failed to identify the existence of a rather large, circumferential notch (1.2 in.) located approximately mid-span on the disk. The small changes introduced by the notch could not be differentiated from the mechanical and electrical noise of the rotor system. It should be noted that although the crack detection techniques of interest failed to identify the existence of the notch, the vibration data captured here will be utilized in upcoming studies that will focus on various data mining techniques concerning damage detection in a disk. Software is currently being developed that will filter the data leaving displacement values that are a function of the disk's centrifugal expansion. Such data will then be used to calculate the compliance at each blade location. Analysis from Part 1 (ref. 5) indicated that the compliance changed by over 40 percent when comparing a blade above a healthy portion of the disk to a blade above a notched portion of the disk. Also, there are other application interests regarding the innovative high temperature, broadband capacitive probe system employed during this study. One technology that requires such a probe concerns active clearance control for increasing engine efficiency and reducing environmentally harmful emissions.

## References

1. Haase, W.C. and Drumm, M.J., "Detection, Discrimination, and Real-Time Tracking of Cracks in Rotating Disks," *SPIE's NDE and Health Monitoring of Aerospace Materials and Civil Infrastructures*, San Diego, California, March, 2002.
2. Sonnichsen, H.E. and Milatovic, B., "Detecting Anomalies in Rotating Components," United States Patent 6456945 B1, September 24, 2002.
3. Lewicki, D.G, Emmerling, W.C., Altobelli, D., Seng, S., Frankenberger, C., and Fila, L., "TF41 Engine Fan Disk Seeded Fault Crack Propagation Test," NASA/TM—2004-213092.
4. Luo, H., Rodriguez, H., Hallman, D., and Corbly, D., "Disk Crack Detection for Seeded Fault Engine Test," NASA/CR—2004-213069.
5. Gyekenyesi, A.L., Sawicki, J.T., and Baaklini, G.Y., "Vibration based Crack Detection in a Rotating Disk: Part 1- An Analytical Study," NASA/TM—2003-212624.
6. Vance, J.M., "Rotordynamics of Turbomachinery," A Wiley-Interscience Publication, New York, 1988.
7. Miller, I. and Freund, J.E., "Probability and Statistics for Engineers," Prentice-Hall, Inc., Englewood Cliffs, New Jersey, 1985.



# REPORT DOCUMENTATION PAGE

*Form Approved*  
OMB No. 0704-0188

Public reporting burden for this collection of information is estimated to average 1 hour per response, including the time for reviewing instructions, searching existing data sources, gathering and maintaining the data needed, and completing and reviewing the collection of information. Send comments regarding this burden estimate or any other aspect of this collection of information, including suggestions for reducing this burden, to Washington Headquarters Services, Directorate for Information Operations and Reports, 1215 Jefferson Davis Highway, Suite 1204, Arlington, VA 22202-4302, and to the Office of Management and Budget, Paperwork Reduction Project (0704-0188), Washington, DC 20503.

<b>1. AGENCY USE ONLY</b> ( <i>Leave blank</i> )	<b>2. REPORT DATE</b> September 2005	<b>3. REPORT TYPE AND DATES COVERED</b> Technical Memorandum	
<b>4. TITLE AND SUBTITLE</b>  Vibration Based Crack Detection in a Rotating Disk Part 2—Experimental Results		<b>5. FUNDING NUMBERS</b>  WBS-22-728-30-06	
<b>6. AUTHOR(S)</b>  Andrew L. Gyekenyesi, Jerzy T. Sawicki, Richard E. Martin, Wayne C. Haase, and George Y. Baaklini		<b>8. PERFORMING ORGANIZATION REPORT NUMBER</b>  E-14182-1	
<b>7. PERFORMING ORGANIZATION NAME(S) AND ADDRESS(ES)</b>  National Aeronautics and Space Administration John H. Glenn Research Center at Lewis Field Cleveland, Ohio 44135-3191		<b>10. SPONSORING/MONITORING AGENCY REPORT NUMBER</b>  NASA TM-2005-212624-PART2	
<b>9. SPONSORING/MONITORING AGENCY NAME(S) AND ADDRESS(ES)</b>  National Aeronautics and Space Administration Washington, DC 20546-0001		<b>11. SUPPLEMENTARY NOTES</b> Andrew L. Gyekenyesi, e-mail: Andrew.L.Gyekenyesi@grc.nasa.gov, Ohio Aerospace Institute, 22800 Cedar Point Road, Brook Park, Ohio 44142; Jerzy T. Sawicki, e-mail: j.sawicki@csuohio.edu and Richard E. Martin, e-mail: Richard.E.Martin@grc.nasa.gov, Cleveland State University, 2121 Euclid Avenue, Cleveland, Ohio 44115-2226; Wayne C. Haase, e-mail: whaase@summitsafetyinc.com, Aerogage, Inc., 7 Matthew Lane, Sterling, Massachusetts 01564; and George Y. Baaklini, e-mail: George.Y.Baaklini@grc.nasa.gov, NASA Glenn Research Center. Responsible person, George Y. Baaklini, organization code RIO, 216-433-6016.	
<b>12a. DISTRIBUTION/AVAILABILITY STATEMENT</b> Unclassified - Unlimited Subject Categories: 31, 05, 07, 35, and 03 Available electronically at <a href="http://gltrs.grc.nasa.gov">http://gltrs.grc.nasa.gov</a> This publication is available from the NASA Center for AeroSpace Information, 301-621-0390.		<b>12b. DISTRIBUTION CODE</b>	
<b>13. ABSTRACT</b> ( <i>Maximum 200 words</i> ) <p>This paper describes the experimental results concerning the detection of a crack in a rotating disk. The goal was to utilize blade tip clearance and shaft vibration measurements to monitor changes in the system's center of mass and/or blade deformation behaviors. The concept of the approach is based on the fact that the development of a disk crack results in a distorted strain field within the component. As a result, a minute deformation in the disk's geometry as well as a change in the system's center of mass occurs. Here, a notch was used to simulate an actual crack. The vibration based experimental results failed to identify the existence of a notch when utilizing the approach described above, even with a rather large, circumferential notch (1.2 in.) located approximately mid-span on the disk (disk radius = 4.63 in. with notch at r = 2.12 in.). This was somewhat expected, since the finite element based results in Part 1 of this study predicted changes in blade tip clearance as well as center of mass shifts due to a notch to be less than 0.001 in. Therefore, the small changes incurred by the notch could not be differentiated from the mechanical and electrical noise of the rotor system. Although the crack detection technique of interest failed to identify the existence of the notch, the vibration data produced and captured here will be utilized in upcoming studies that will focus on different data mining techniques concerning damage detection in a disk.</p>			
<b>14. SUBJECT TERMS</b>  Health monitoring; Crack detection; Center of mass		<b>15. NUMBER OF PAGES</b> 18	<b>16. PRICE CODE</b>
<b>17. SECURITY CLASSIFICATION OF REPORT</b> Unclassified	<b>18. SECURITY CLASSIFICATION OF THIS PAGE</b> Unclassified	<b>19. SECURITY CLASSIFICATION OF ABSTRACT</b> Unclassified	<b>20. LIMITATION OF ABSTRACT</b>