

Flammability Aspects of a Cotton-Fiberglass Fabric in Opposed and Concurrent Airflow in Microgravity



NCSER
FLUIDS & COMBUSTION

Paul Ferkul, National Center for Space Exploration Research

Sandra Olson, NASA Glenn Research Center

Michael Johnston, Case Western Reserve University

James T'ien, Case Western Reserve University

This work was supported by the NASA Space Life and Physical Sciences Research and Applications Division (SLPSRA).

Presented at the American Society for Gravitational and Space Research 2012 Annual Meeting
New Orleans, Louisiana

Science Background:

- ◆ Combustion of solid fuels in microgravity has been an active area of research
- ◆ Numerical models predict that 1-g buoyant flows profoundly affect fuel flammability
- ◆ Microgravity experiments burning thin fuels have verified this prediction, but ground-based facilities are too short to examine the burning of thicker fuels
- ◆ Flow in range < 30 cm/s is of interest

Typical Flammability Boundary for a Solid Fuel

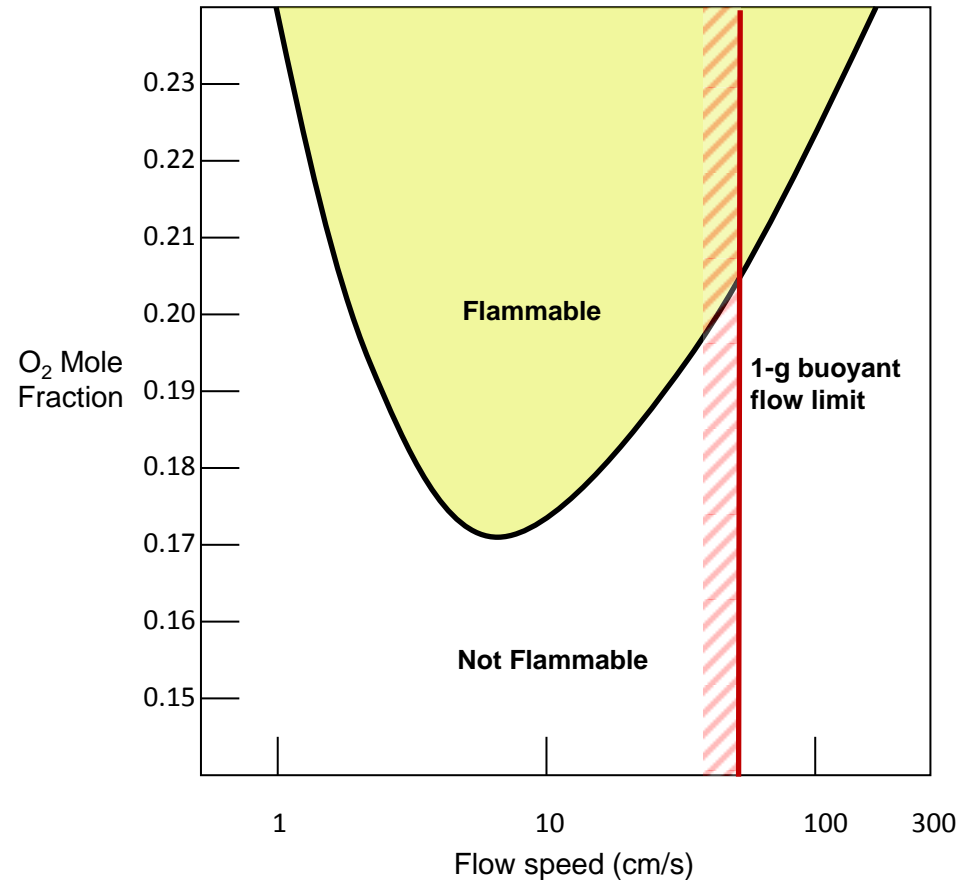

Hypotheses:

- ◆ Materials in microgravity, with adequate ventilation, may burn more readily compared to normal gravity with other conditions being identical (pressure, oxygen concentration, temperature, etc.)
- ◆ Testing at constant O_2 mole fraction permits studying flame spread and extinction at low and high flow speed.

Typical Flammability Boundary for a Solid Fuel

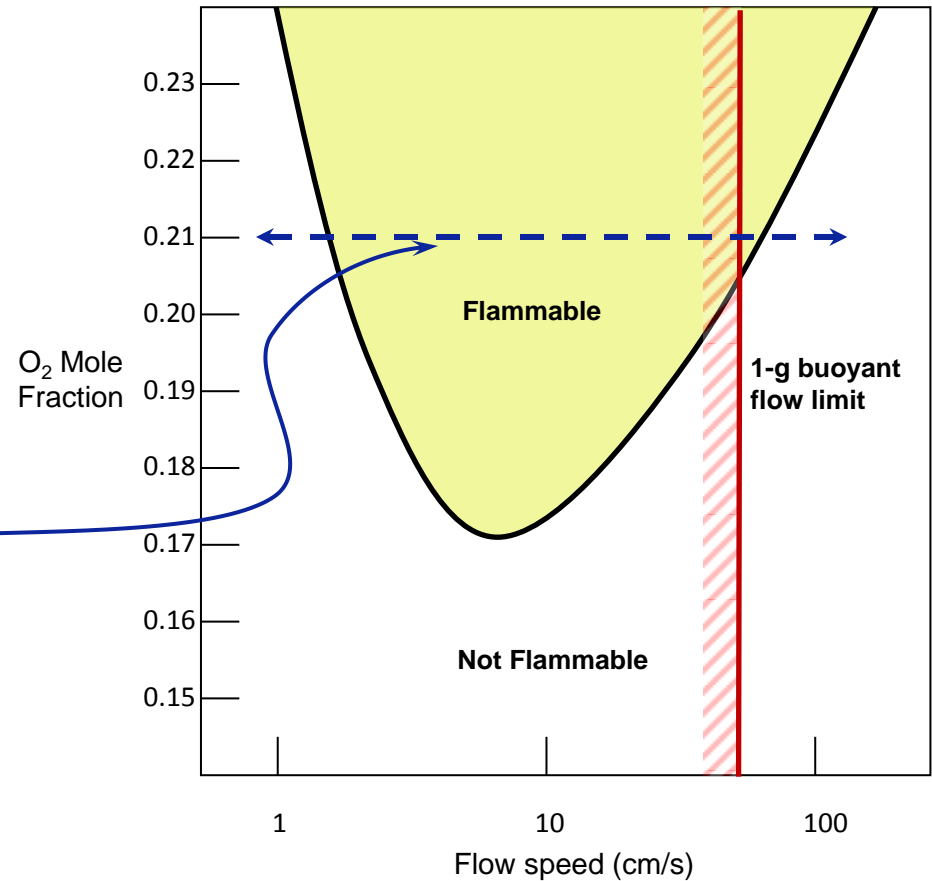

Approach:

- ◆ Microgravity combustion tests were performed aboard the International Space Station using the BASS (Burning and Suppression of Solids) hardware.
- ◆ The wind tunnel was installed in the Microgravity Science Glovebox which supplied power, imaging, and a level of containment.
- ◆ Cotton-fiberglass blend fabric samples were mounted inside a small wind tunnel which could impose airflow speeds up to 40 cm/s.
- ◆ The effects of airflow speed on flame appearance, flame growth, and spread rates were determined in both the opposed and concurrent flow configuration.

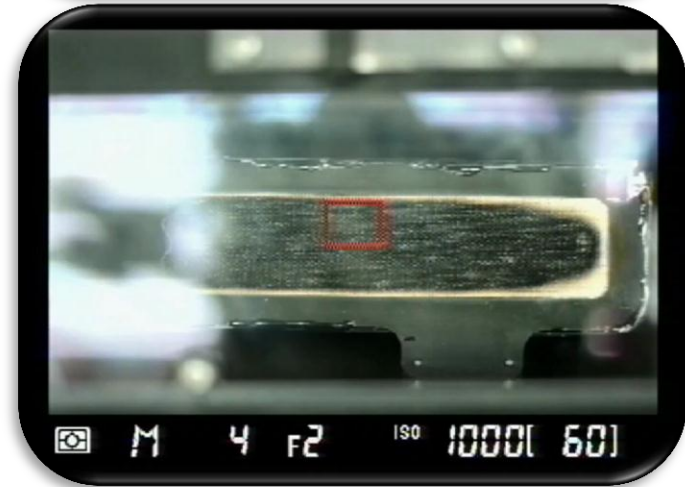

Science Applications:

- ◆ Understanding of long-duration microgravity solid material burning and extinction
- ◆ Improved strategies for NASA spacecraft materials selection; link actual burn behavior in microgravity to Earth-based selection methods
- ◆ Improved combustion computational models used in the design of fire detection and suppression systems in microgravity and on Earth
- ◆ Validated detailed combustion models in the simpler flow environment of microgravity build more complex combustion models needed to capture the important details of flames burning in normal gravity; models have wide applicability to the general understanding of many terrestrial combustion problems.

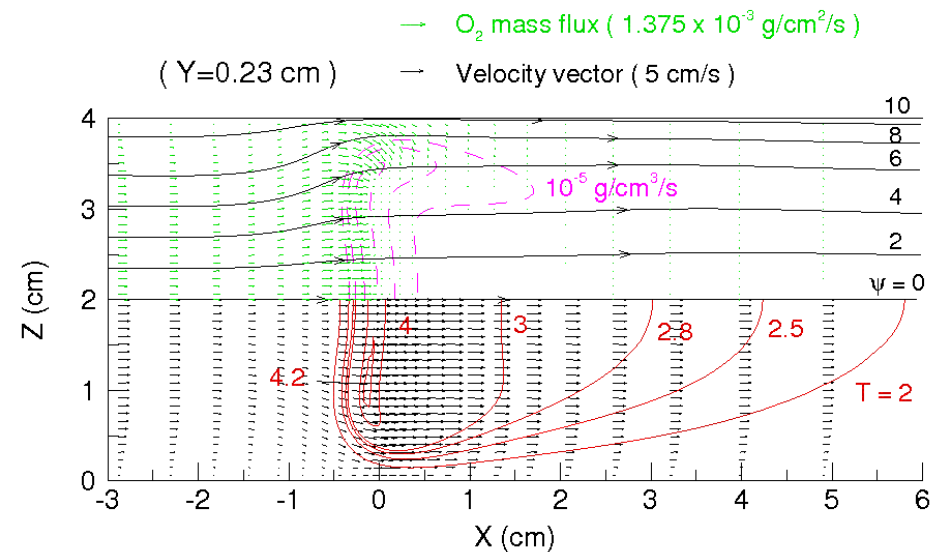
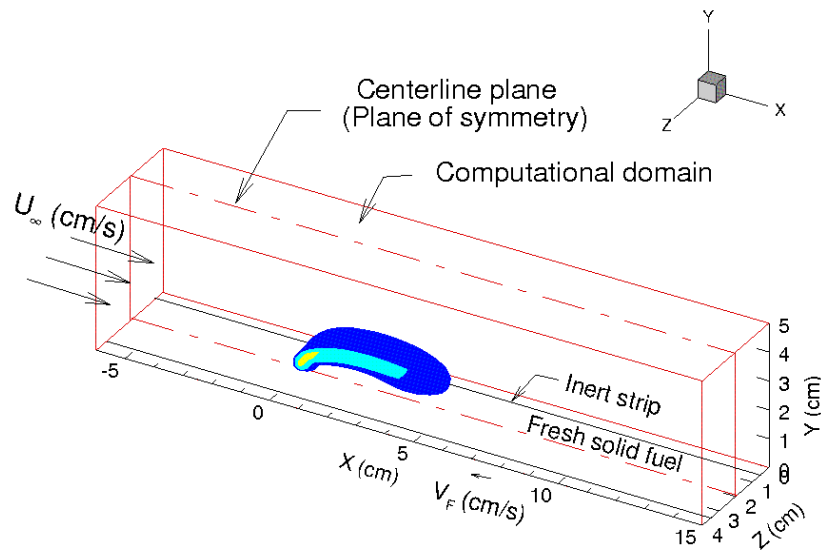

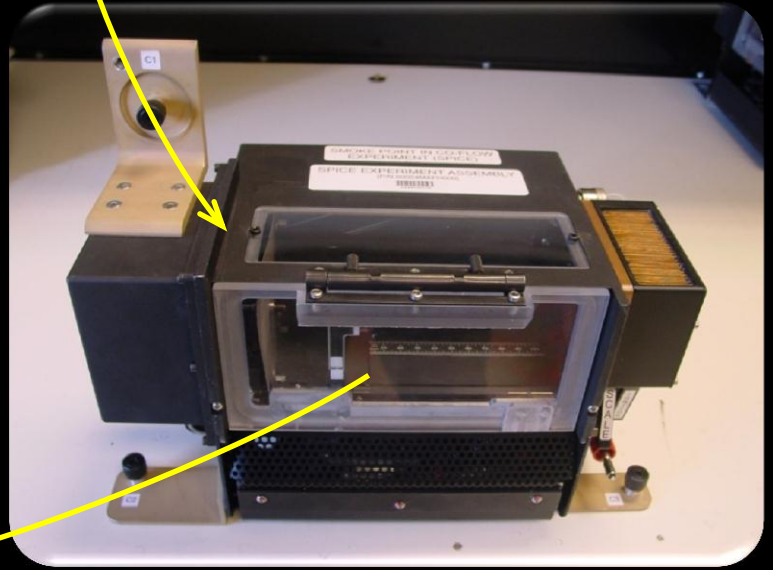
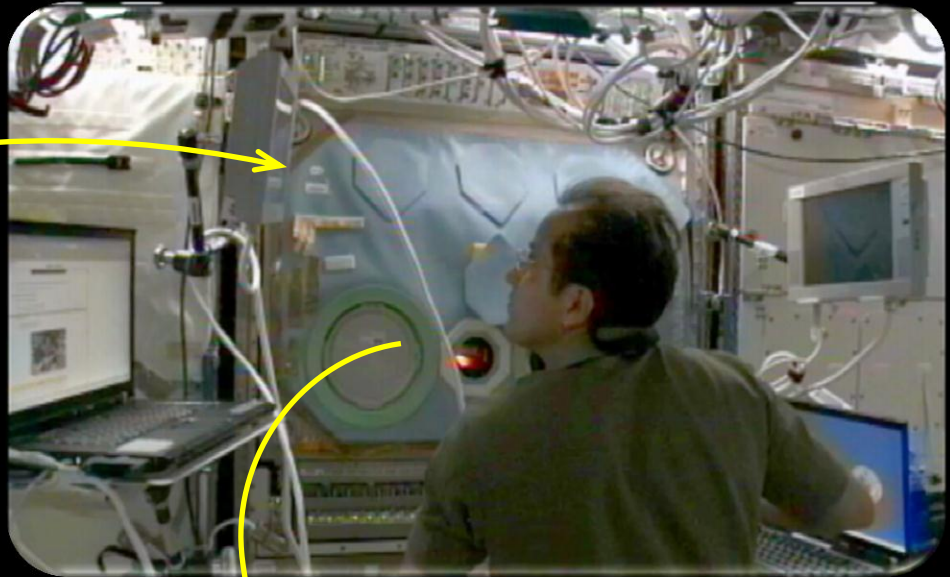
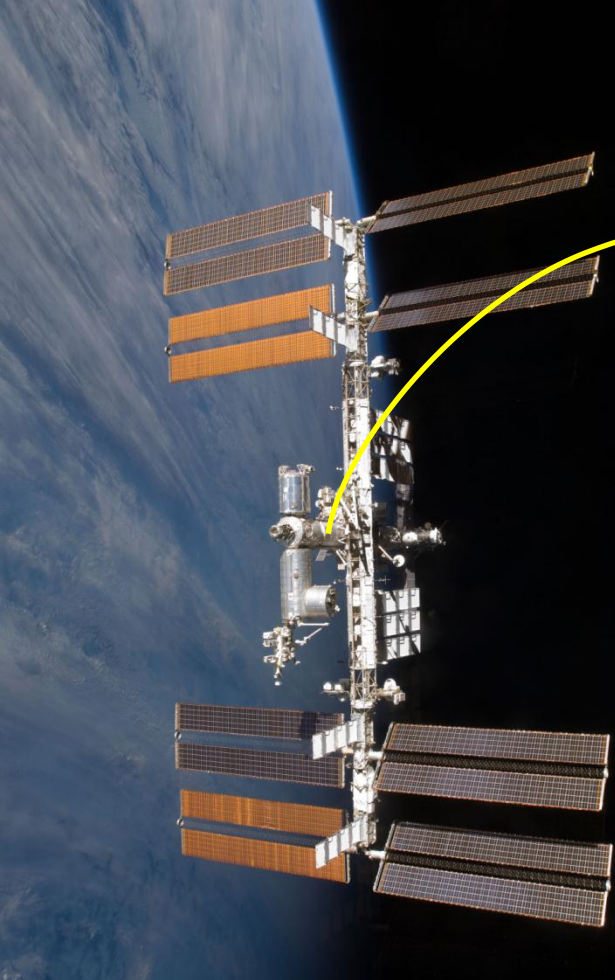

Microgravity Science Glovebox (MSG)

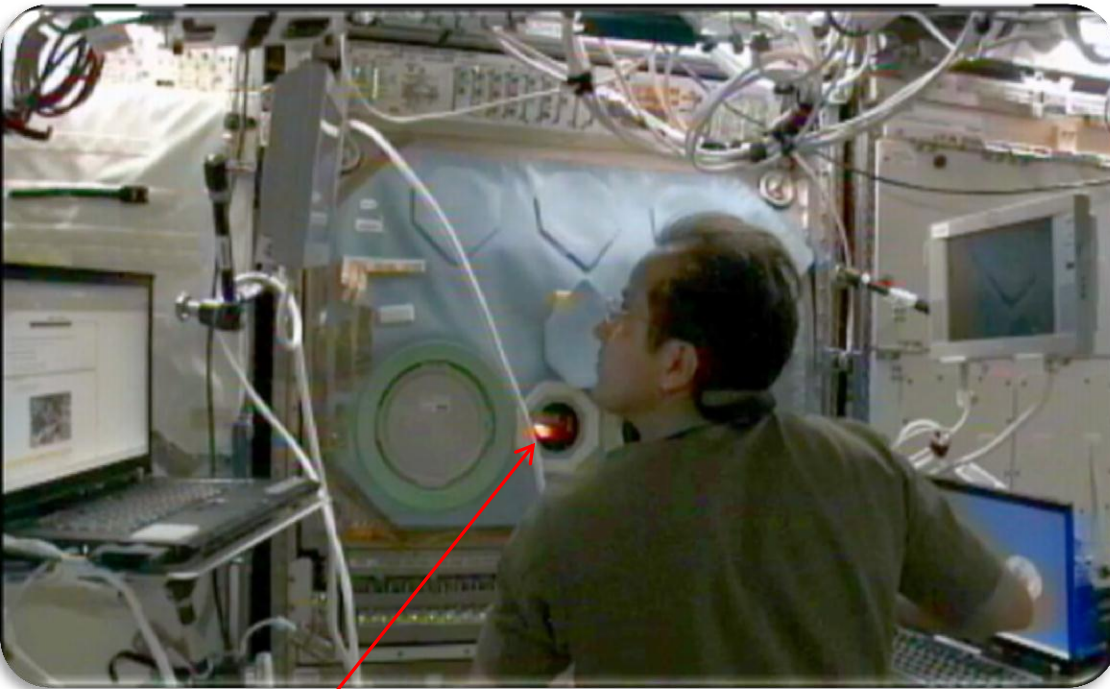

BASS flame visible through viewport

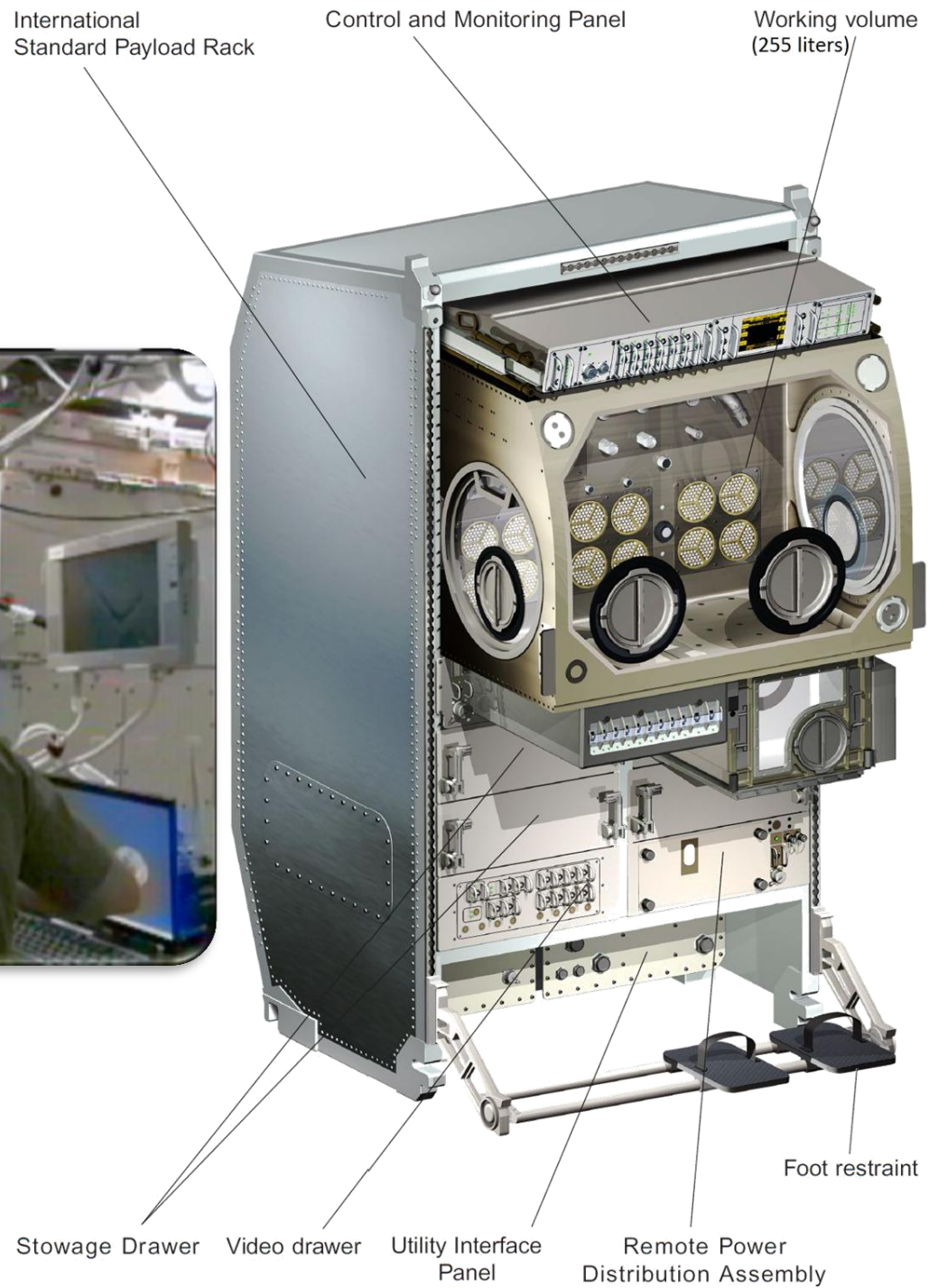

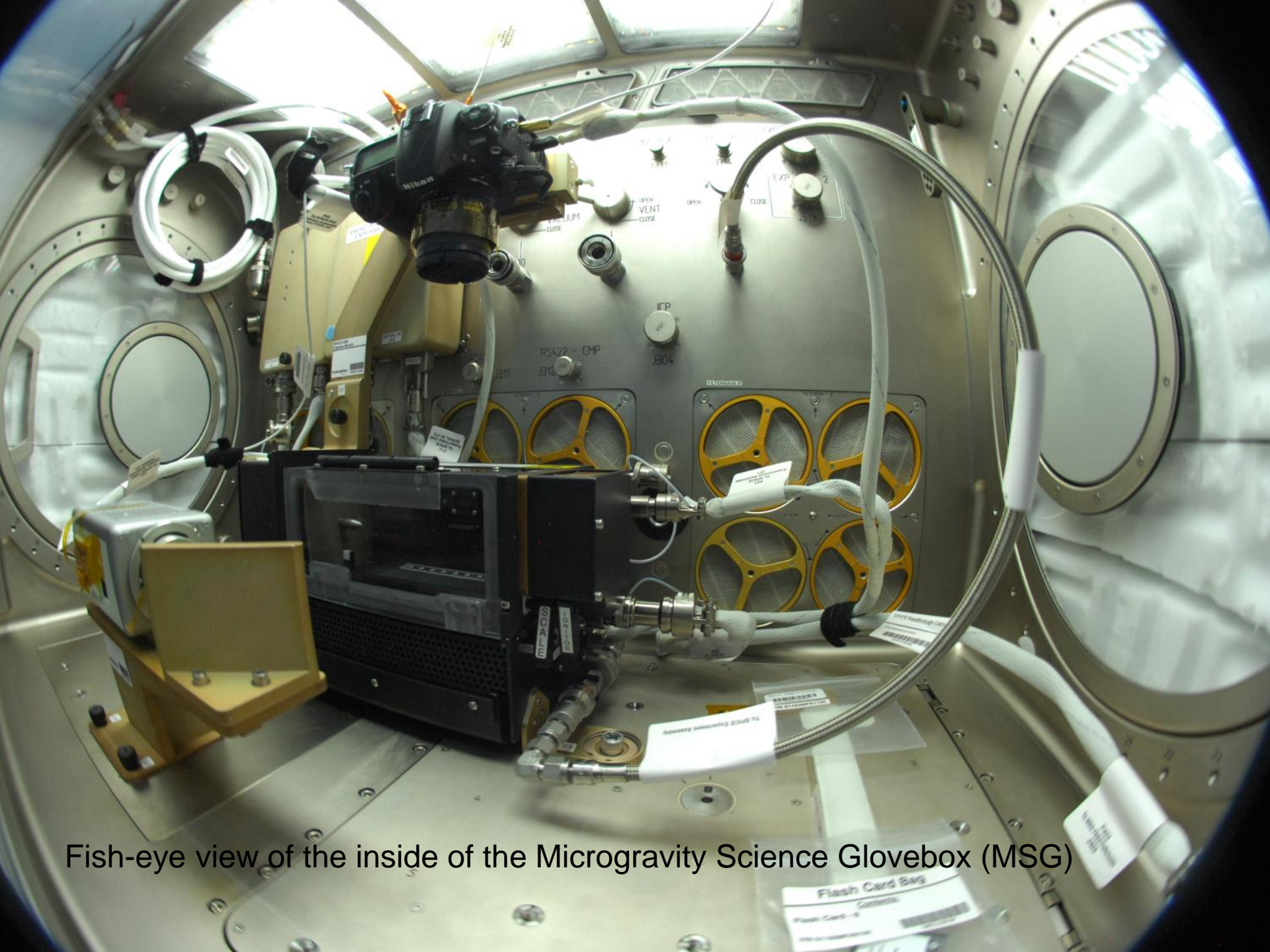

Fish-eye view of the inside of the Microgravity Science Glovebox (MSG)

Hardware Details



Top window

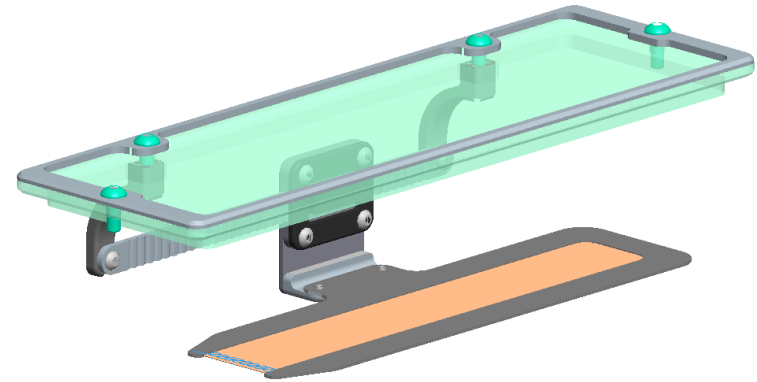

Permits variety of solid samples to be mounted, ignited, and burned:

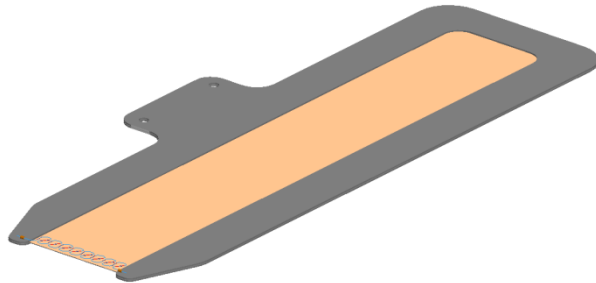

Thin, flat (17)

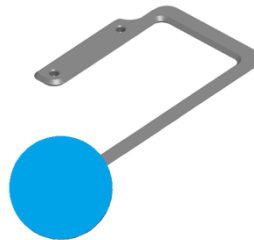

Spheres (12)

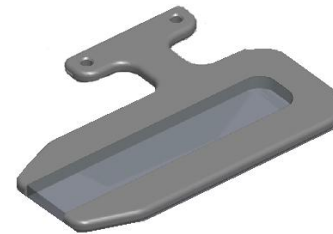

Thick, flat (4)

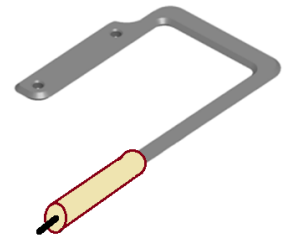

Candles (8)

(Note: samples are not to scale; samples can be flipped 180 degrees if desired)

Experiment Operation:

Top Window and
Sample Holder

Flow Duct

Airflow

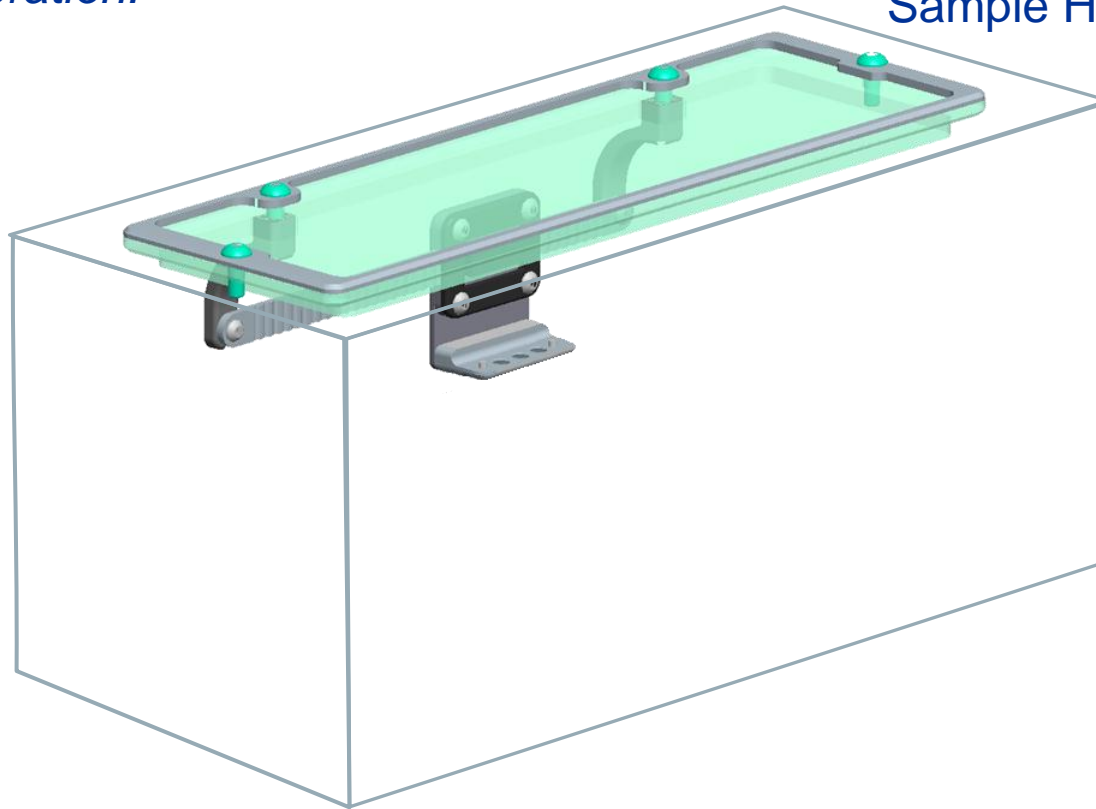

Experiment Operation:

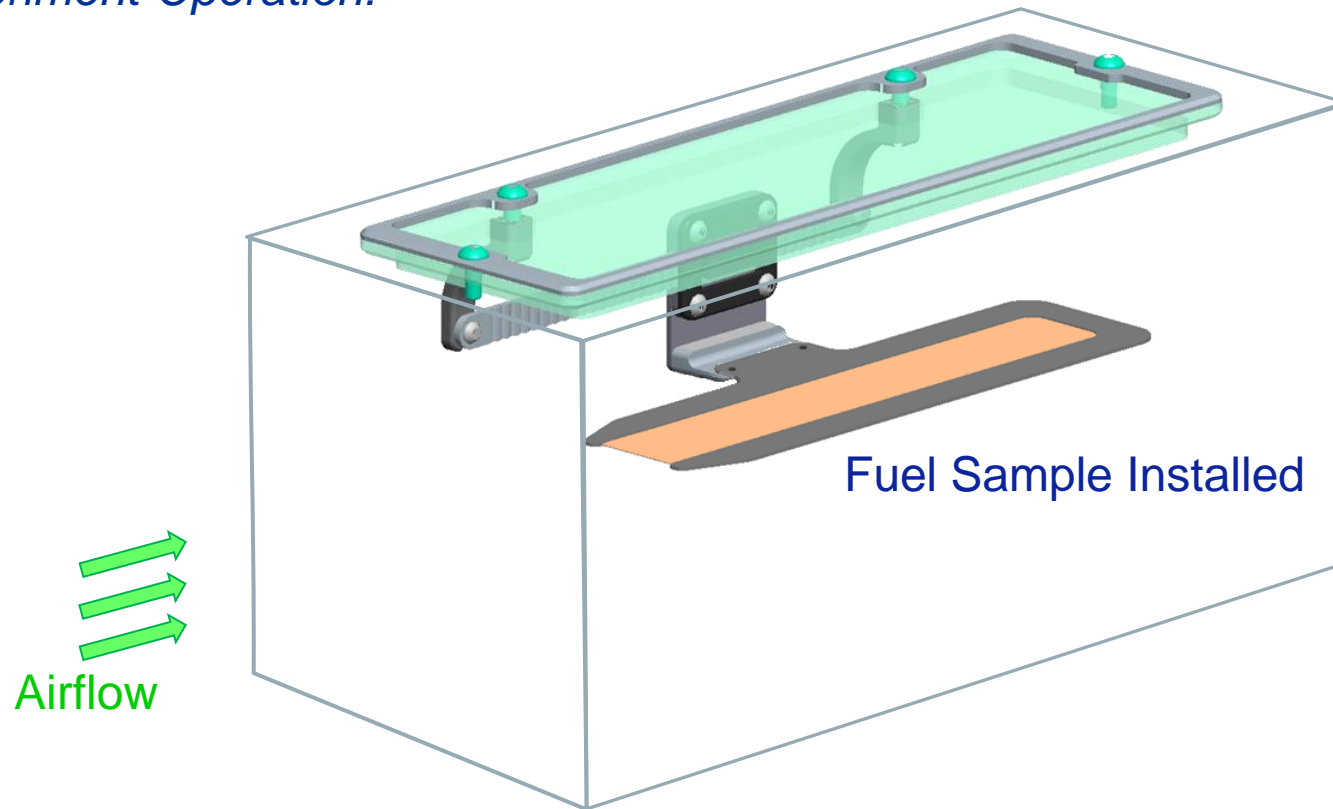

Experiment Operation:

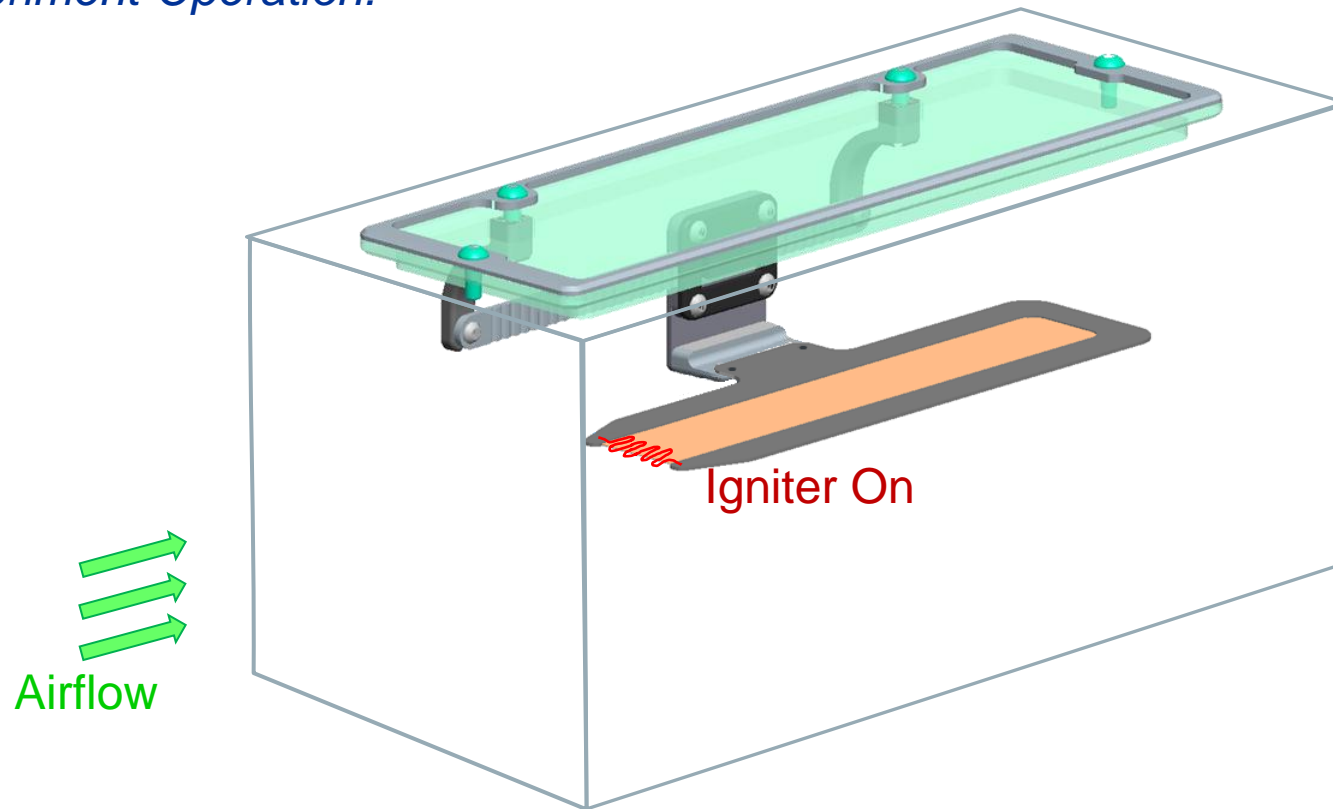

Experiment Operation:

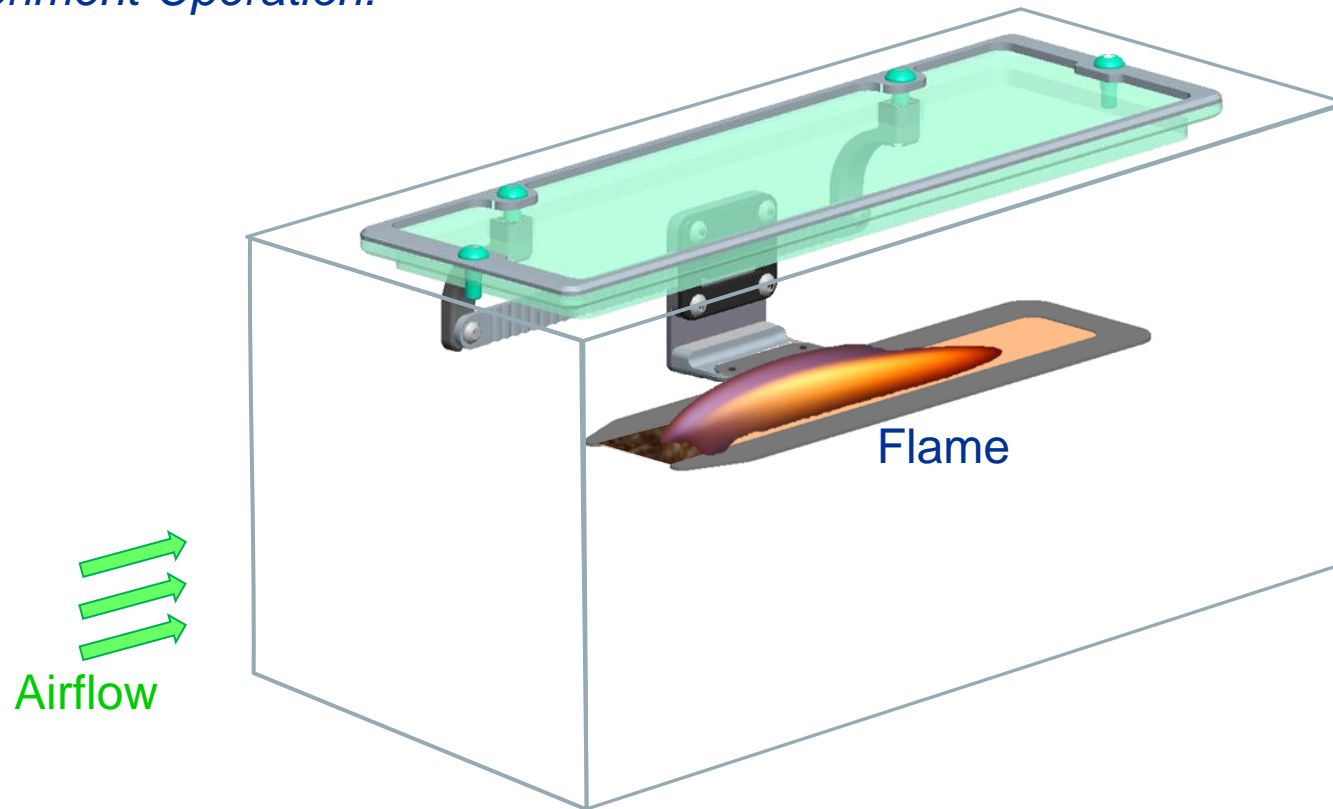

Experiment Operation:

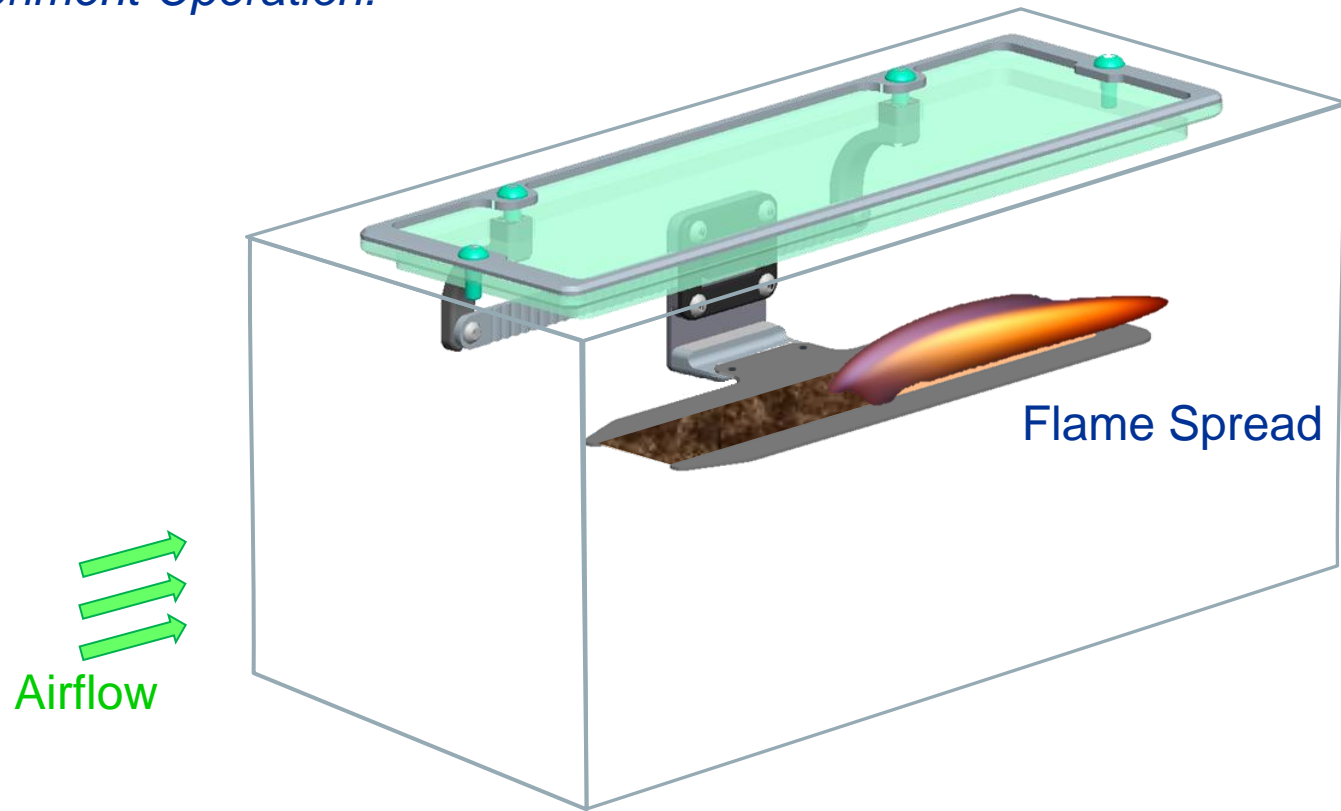

Experiment Operation:

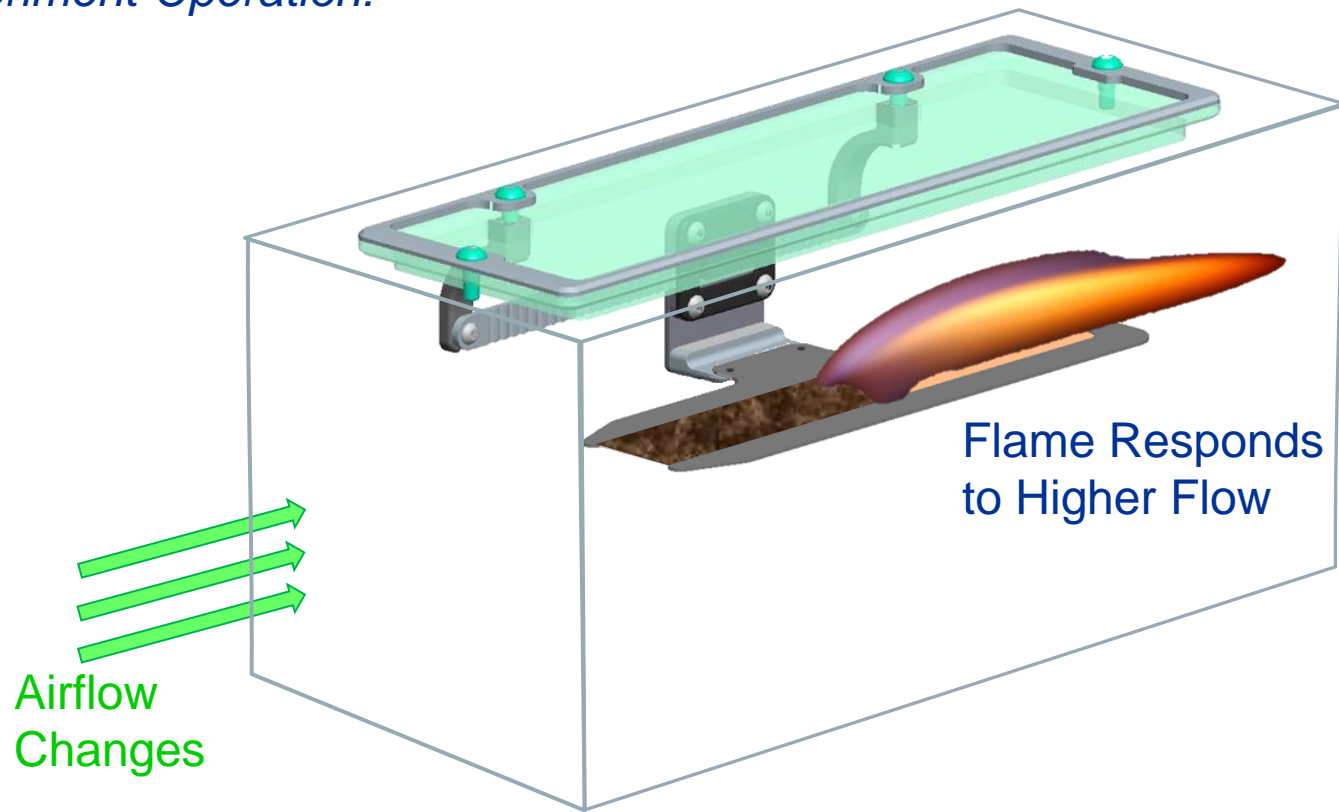

Experiment Operation:

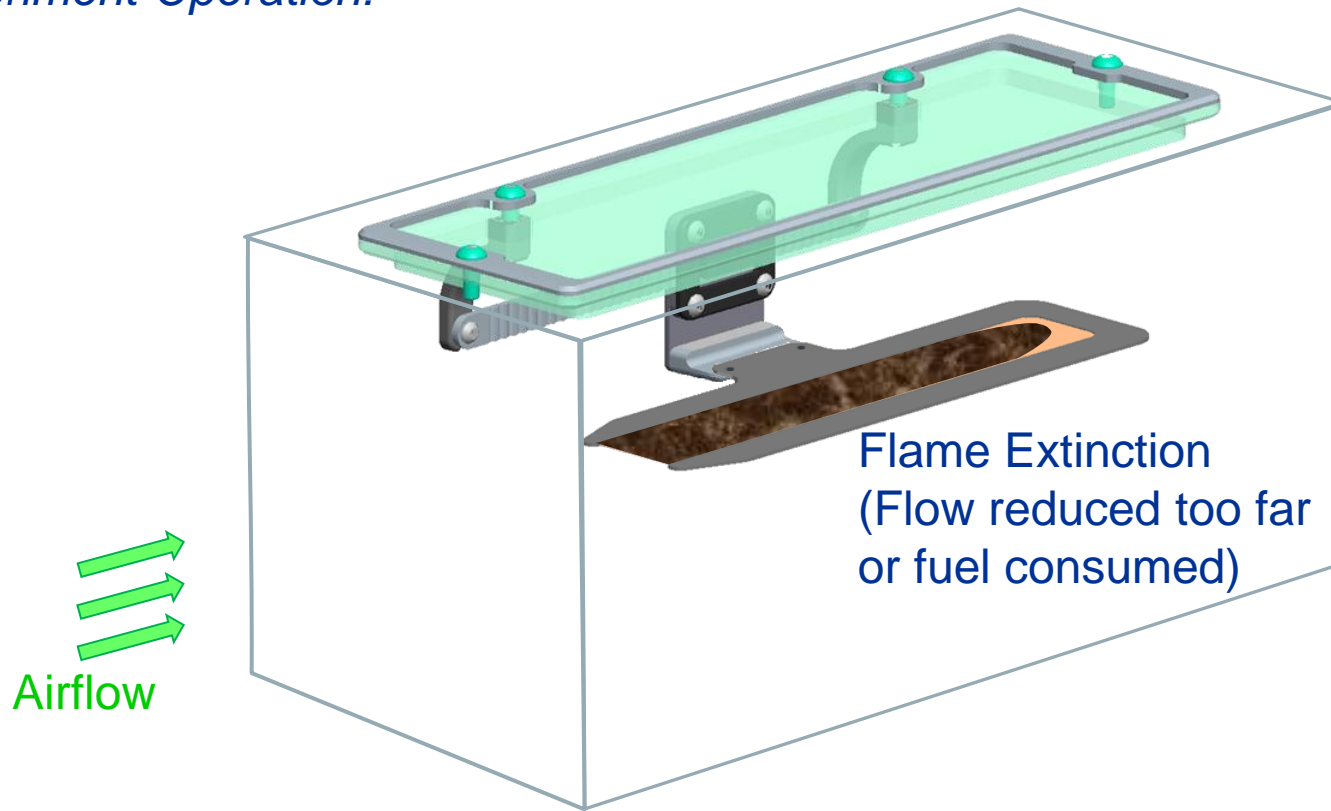

Hardware Summary:

- ◆ BASS utilized the on-orbit SPICE hardware; minor modifications were made to burn solid samples
- ◆ Small flow tunnel
- ◆ Solid samples were installed, ignited, extinguished, and recorded
- ◆ Video and digital still camera provided bulk of the data. Flame appearance, behavior, spread rate, and extinction dynamics were measured
- ◆ Airflow speed was the main variable

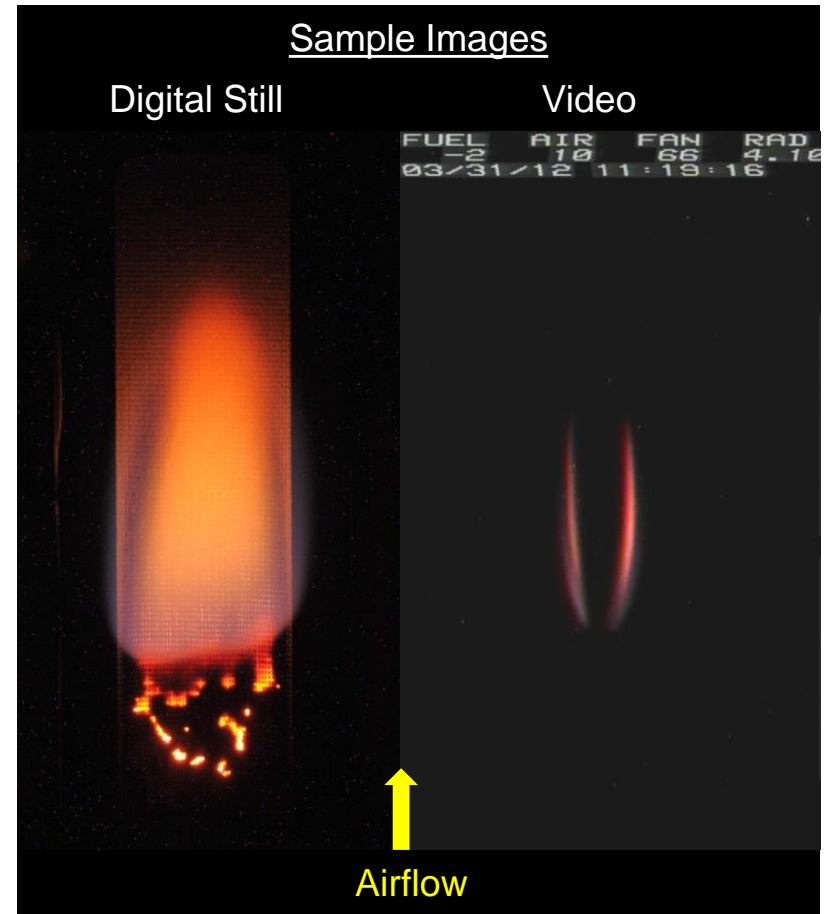

Fuel characteristics ("SIBAL" fabric)

25% fiberglass, 75% cotton blend

Simple weave pattern (60 x 40 threads per inch)

Cotton and fiberglass fibers intermingled

Overall area density: 18 mg/cm²

Fuel sizes: 8.5 cm length; 1 and 2 cm width

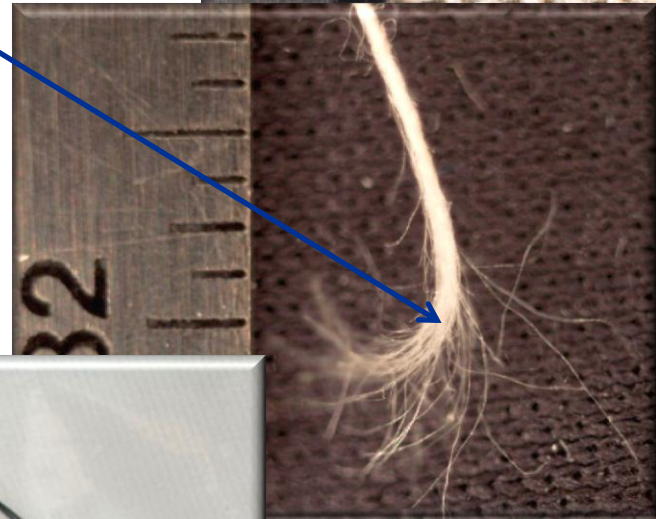
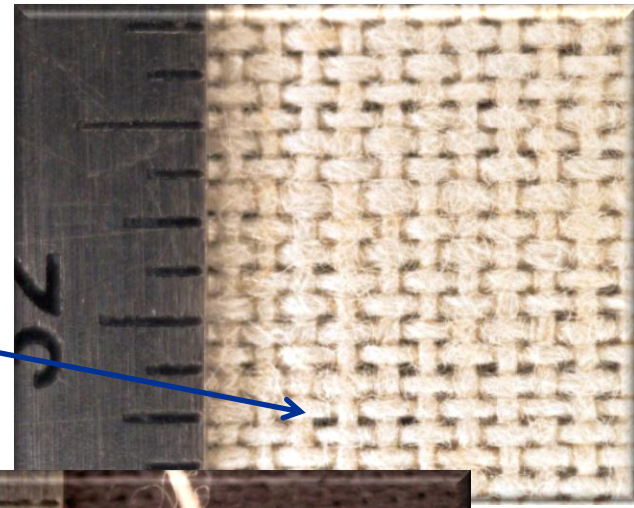

1. Concurrent Flow

```
FUEL  AIR  FAN  RAD
-1    10   66  0.06
03/31/12 11:18:56
```



Airflow

Video (edge view) of 2-cm-wide sample in concurrent flow. Ignition is obtained at an airflow speed of 10 cm/s and flow is then reduced to 5 cm/s.

Effect of flow speed on 2-cm-wide sample in concurrent flow (top view)



10 cm/s Airflow



5 cm/s Airflow



Digital still camera images for 1-cm-wide fuel with concurrent airflow = 10 cm/s. Images are taken every 1.125 sec (starting at bottom and moving from left to right). The flame reaches steady state after about 10 seconds.

Still image analysis; 1 cm-wide fuel, 10 cm/s airflow

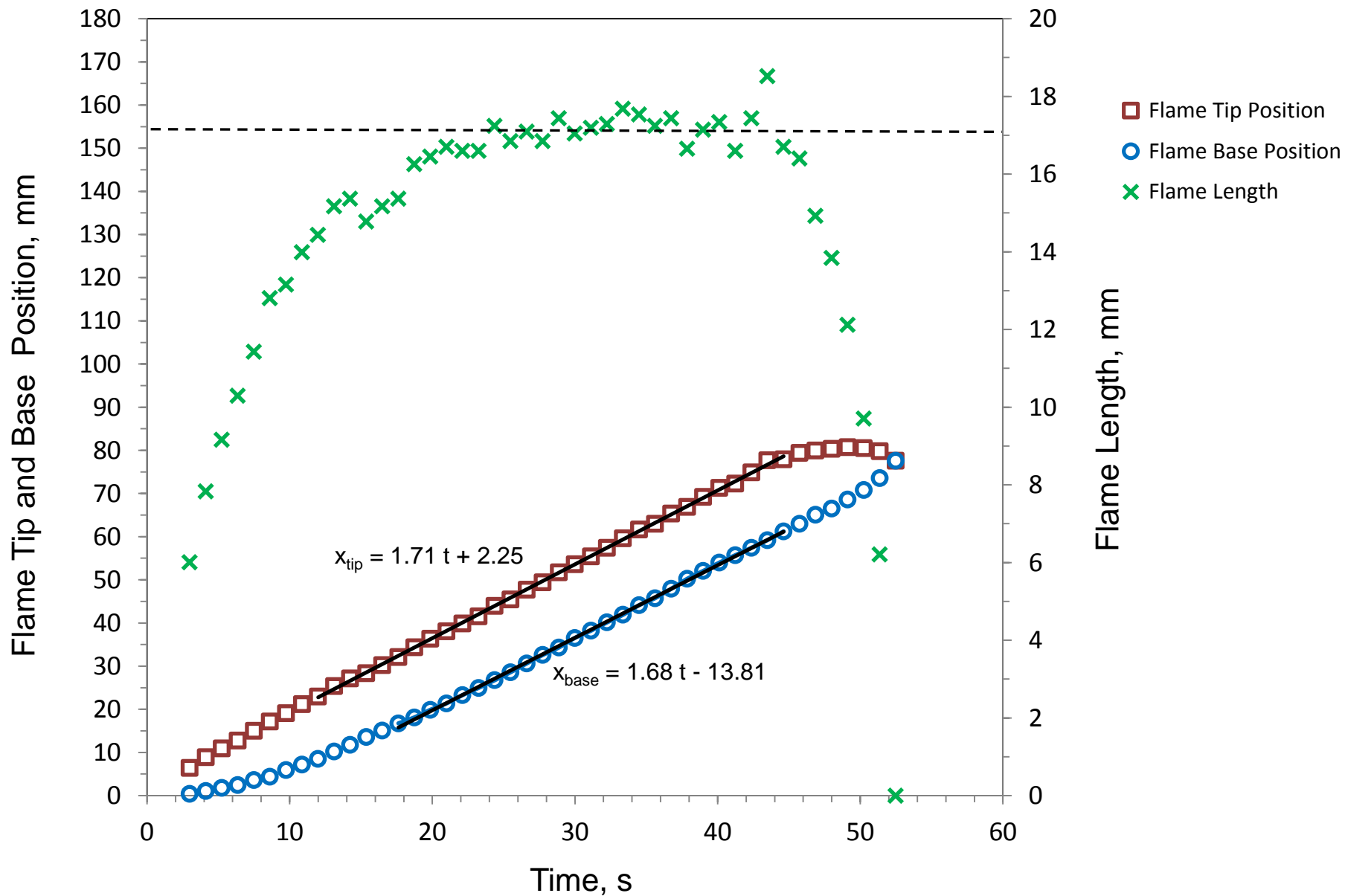

2. Opposed Flow

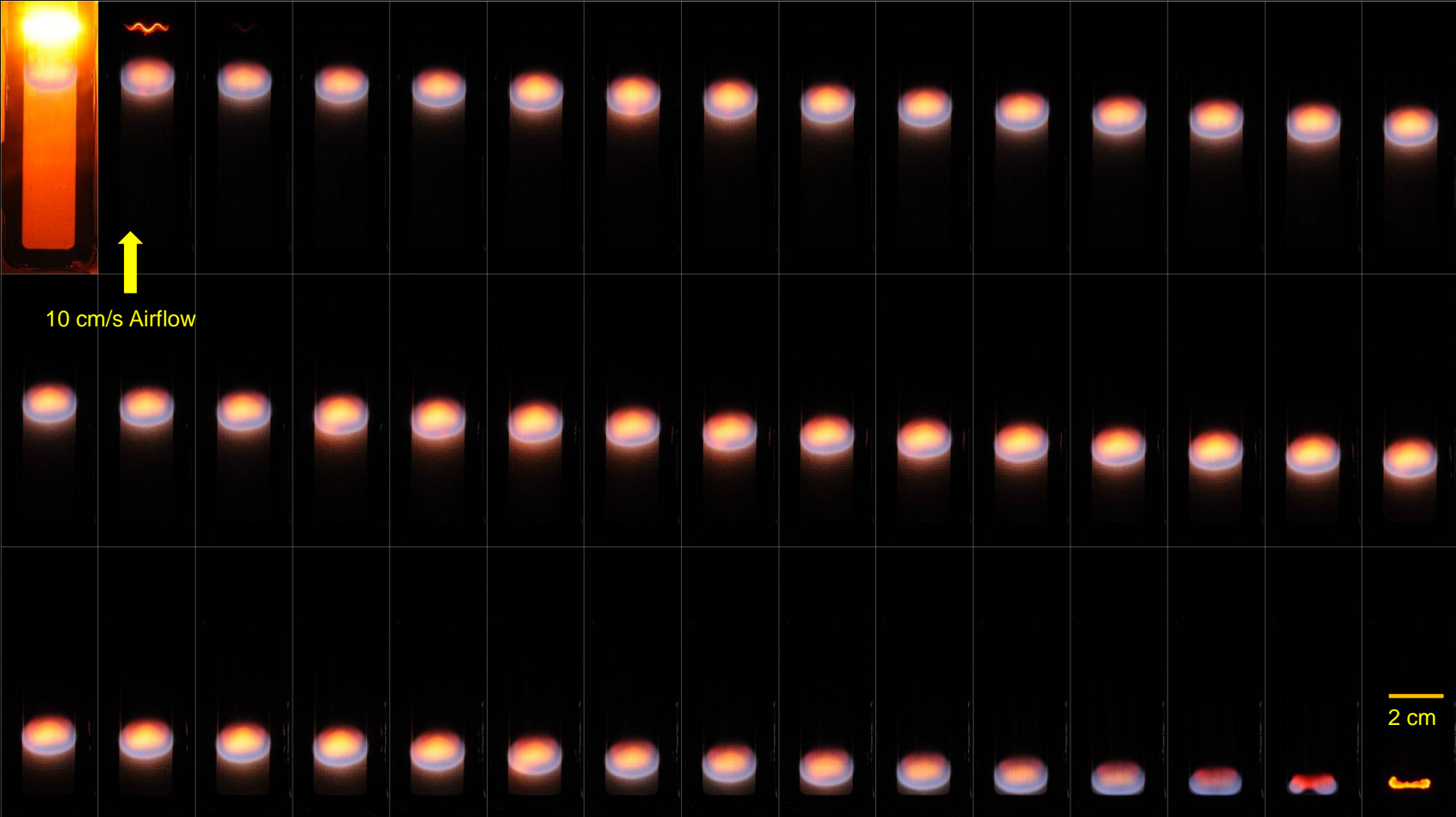

Digital still camera images for 2-cm-wide fuel with opposed airflow = 10 cm/s. Images are taken every 1.25 sec (starting at top and moving from left to right). Flame quickly reaches steady state and goes out when it runs out of fuel.

Note: Downward flame spread (opposed flow) in 1-g with this material is not possible in normal air.

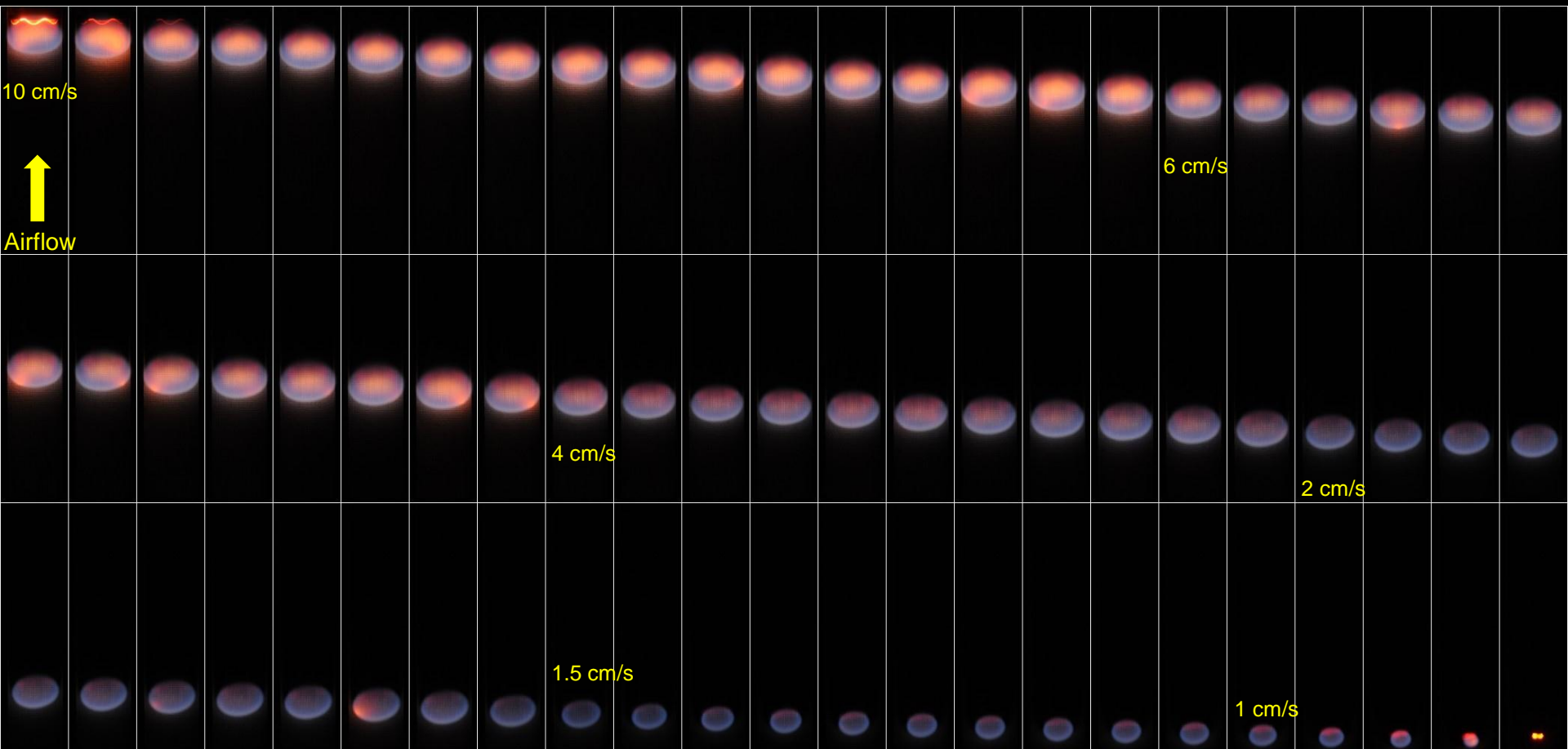

Digital still camera images showing a flame burning a 2-cm wide cotton-fiberglass fabric in opposed flow. Images are taken every 1.25 sec (starting at top and moving from left to right). The flow is decreased in discrete steps from 10 cm/s all the way down to about 1 cm/s. The flame response to flow changes is very rapid, and the flow effects on the flame and its spread rate are dramatic. Total burn time is 90 sec. Flow changes are indicated by numbers.

FUEL	AIR	FAN	RAD
-2	10	51	0-12
07/20/12	09:16:53		





Airflow

Video view of 2-cm-wide sample in opposed flow. Blowoff is attempted at high flow speed (~ 44 cm/s).

3. Comparisons

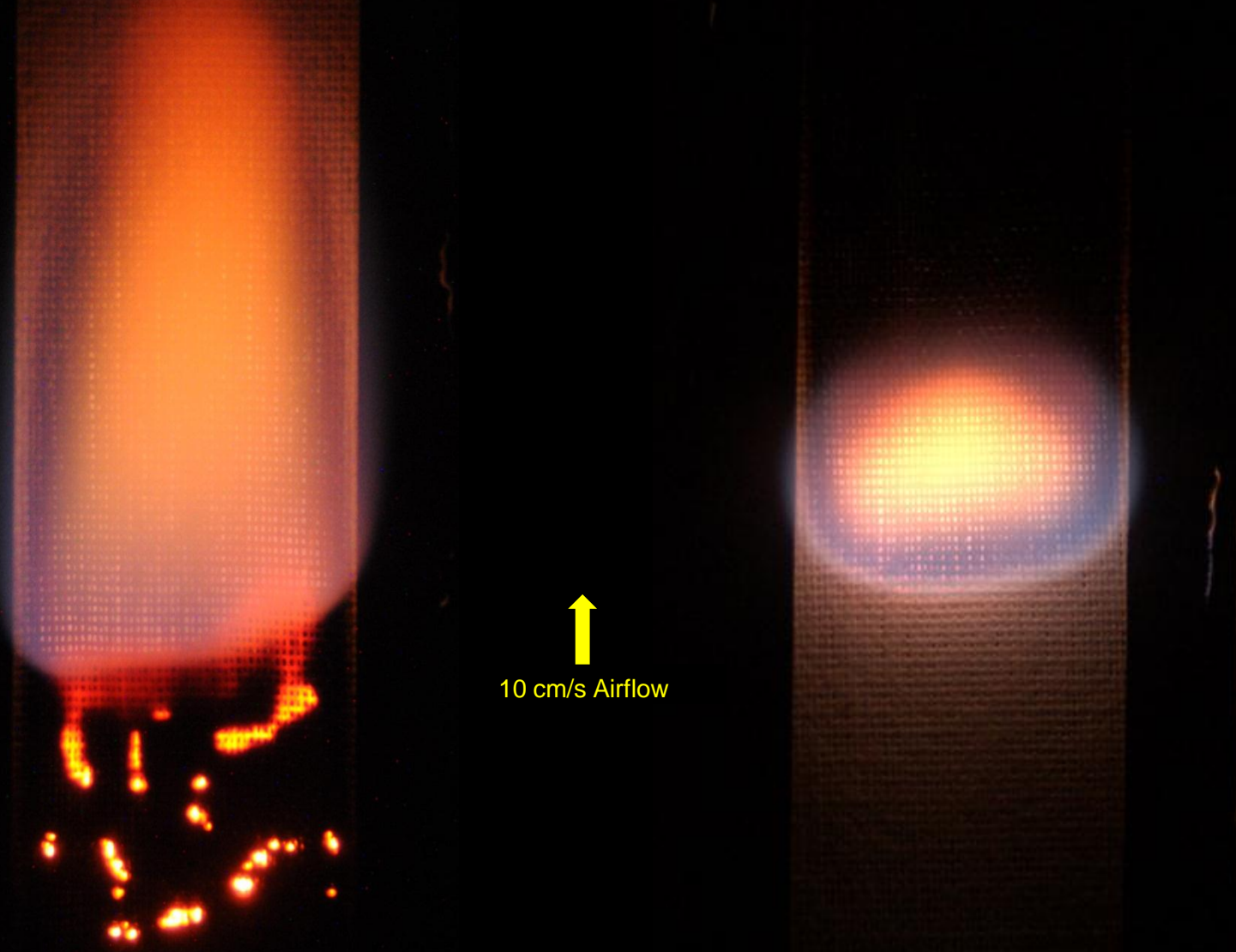
Concurrent and Opposed Spread at ~ 10 cm/s
2.55 mm/s versus 1.21 mm/s



↑
10 cm/s Airflow

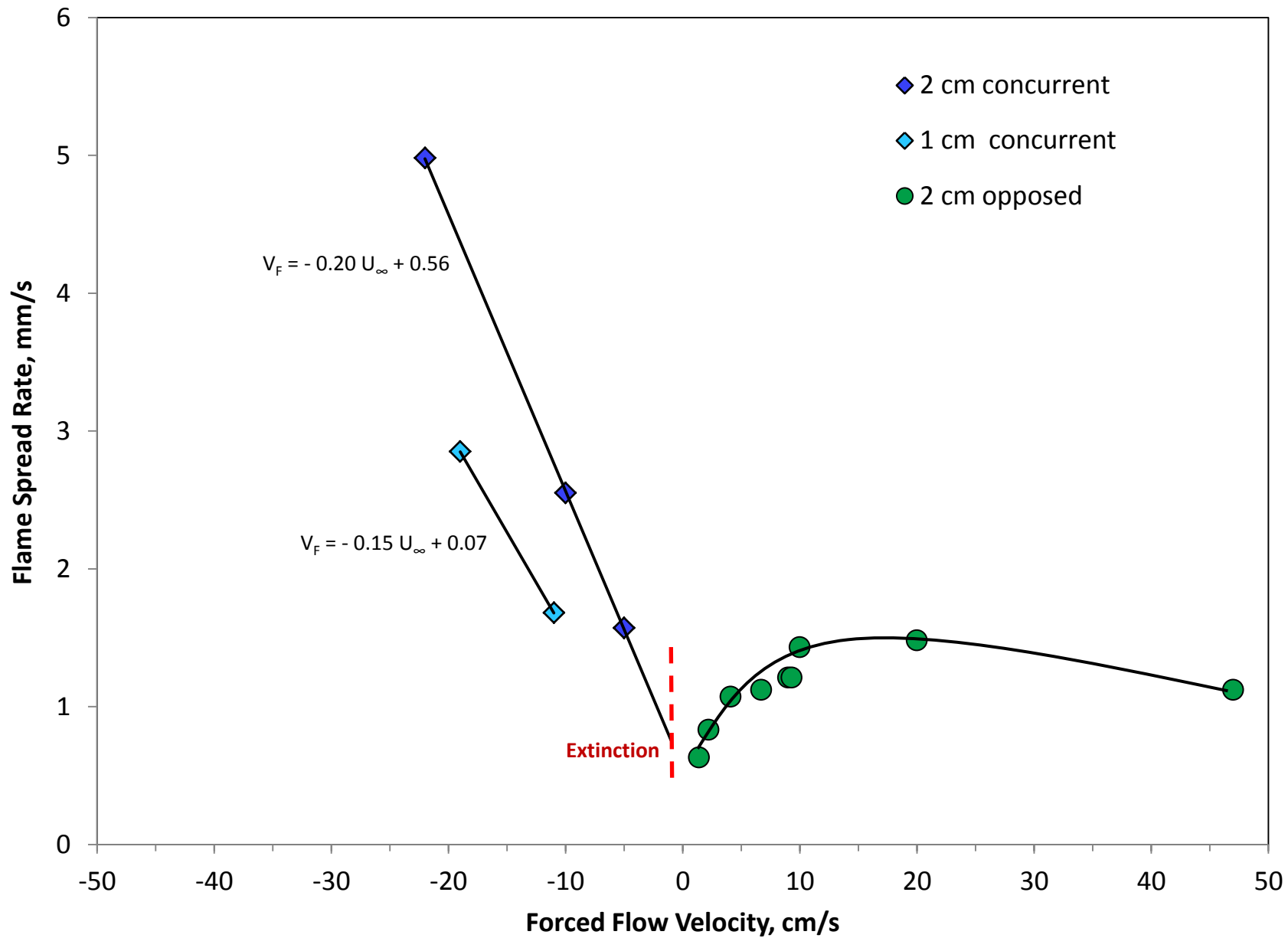

Comparison of 0-g and 1-g Concurrent Flow Flames

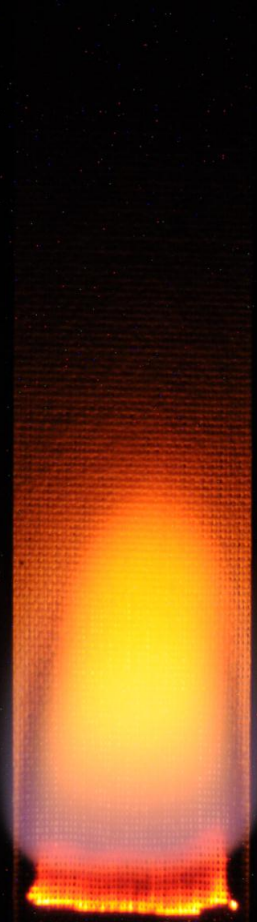

0-g with flow (10 cm/s)
Steady flame size and spread
Convex base
Extended blue zone



1-g with flow (10 cm/s)
Growing flame size and spread
Concave base
Extended soot zone

Comparison of 0-g and 1-g Opposed Flow Flames

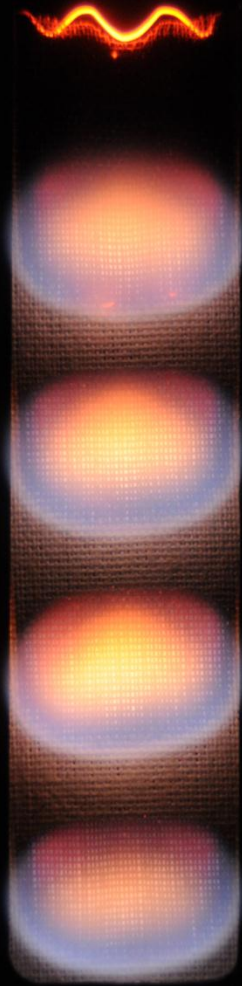

0-g with flow (10 cm/s)
Steady flame size and spread
Convex base
Extended blue zone



1-g
Flame does not propagate downward

Summary

- ◆ For the opposed flow configuration, the flame quickly reached steady spread for each flow speed, and the spread rate was fastest at an intermediate value of flow speed.
- ◆ These tests show the enhanced flammability in microgravity for this geometry, since, in normal gravity air, a flame self-extinguishes in the opposed flow geometry (downward flame spread).
- ◆ For the concurrent flow configuration, a limiting length and steady spread rate were obtained only in low flow speeds. For these conditions, flame spread rate increased linearly with increasing flow.
- ◆ This is the first time that detailed transient flame growth data was obtained in purely forced flows in microgravity. In addition, by decreasing concurrent flow speed to a very low value (around 1 cm/s), quenching extinction was observed.
- ◆ The valuable results from these long-duration experiments validate a number of theoretical predictions and also provide the data for a transient flame growth model under development.



Acknowledgments:

Fumiaki Takahashi, National Center for Space Exploration Research

Bob Hawersaat, NASA Glenn Research Center

Jay Owens, National Center for Space Exploration Research

Tibor Lorik, ZIN Technologies

Chuck Bunnell, ZIN Technologies

Carol Reynolds, NASA Marshall Space Flight Center

Don Pettit, NASA Johnson Space Center

Joe Acaba, NASA Johnson Space Center

Suni Williams, NASA Johnson Space Center

Questions?



Astronauts Don Pettit, Joe Acaba, and Suni Williams return to Earth, Kazakhstan, 2012

Backup Slides

Effect of flow speed on sample in concurrent flow (edge view)



2 cm wide, 20 cm/s Airflow



1 cm wide, 10 cm/s Airflow



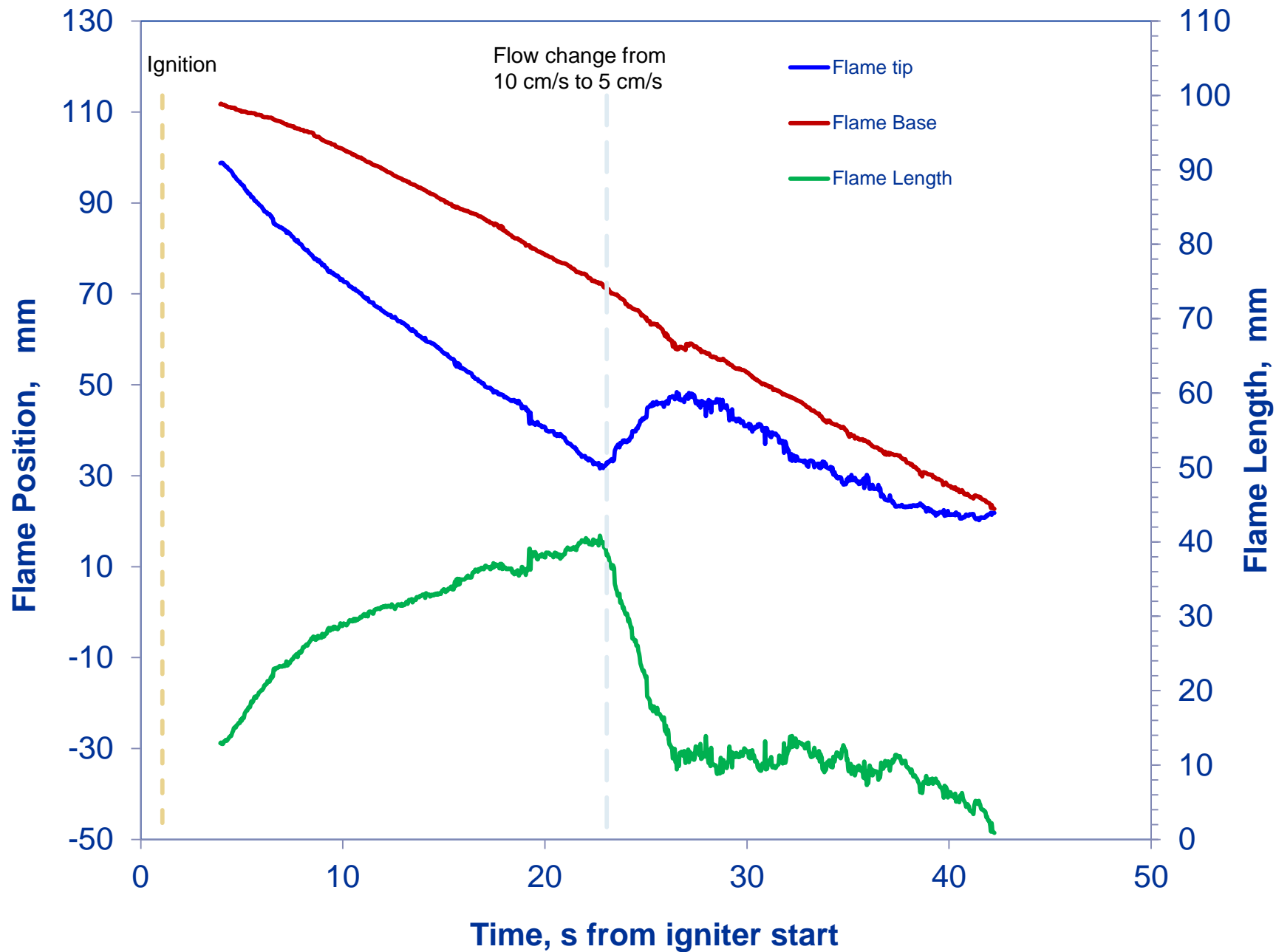

Sample Model Results:

