

General Disclaimer

One or more of the Following Statements may affect this Document

- This document has been reproduced from the best copy furnished by the organizational source. It is being released in the interest of making available as much information as possible.
- This document may contain data, which exceeds the sheet parameters. It was furnished in this condition by the organizational source and is the best copy available.
- This document may contain tone-on-tone or color graphs, charts and/or pictures, which have been reproduced in black and white.
- This document is paginated as submitted by the original source.
- Portions of this document are not fully legible due to the historical nature of some of the material. However, it is the best reproduction available from the original submission.

Using CFD Techniques to Predict Slosh Force Frequency and Damping Rate

Brandon Marsell¹, Sathya Gangadharan², and Yadira Chatman³
Embry-Riddle Aeronautical University, Daytona Beach, FL 32114

James Sudermann⁴
NASA, Kennedy Space Center, FL 32899

Resonant effects and energy dissipation due to sloshing fuel inside propellant tanks are problems that arise in the initial design of any spacecraft or launch vehicle. A faster and more reliable method for calculating these effects during the design stages is needed. Using Computational Fluid Dynamics (CFD) techniques, a model of these fuel tanks can be created and used to predict important parameters such as resonant slosh frequency and damping rate. This initial study addresses the case of free surface slosh. Future studies will focus on creating models for tanks fitted with propellant management devices (PMD) such as diaphragms and baffles.

I. Introduction:

During the initial stages of spacecraft and launch vehicle design, it is important to account for the forces created by the sloshing propellant in the fuel tanks. The variable conditions under which these propellant tanks operate make analytical models rather difficult to construct. There exists some very good predictive tools for bare tanks of certain geometries, but the addition of baffles, diaphragms, bladders and other slosh control devices invalidates the results obtained by these tools. A strong desire exists to perform large scale Monte Carlo statistical analyses on spacecraft and launch vehicle dynamic behavior in order to account for these variable conditions. A five or ten thousand case Monte Carlo study requires a simplified slosh model that can run rapidly in order to compute in a reasonable amount of time. Using a primary CFD model to determine parameters for a simplified mechanical analog slosh model holds great promise in terms of increasing accuracy and saving time, money, and effort on physical ground testing. For this reason, this study will focus on a more modern approach that uses computational fluid dynamics techniques to help model the liquid propellant slosh.

In three axis stabilized spacecraft, coupling between the spacecraft or upper stage flight control system and an unanticipated slosh resonance can result in disaster as seen in the Space X Falcon 1 mission launched in 2007. Unforeseen slosh resonances can result in excessive attitude control fuel usage, pointing or attitude control issues that may violate mission requirements. For this reason it is important to fully understand the slosh dynamics of propellants in fuel tanks.

In the case of spin stabilized spacecraft, any sloshing motion of the fuel will cause a loss of kinetic energy of the spacecraft. Since the stabilization of these particular vehicles is dependant on their spin, a loss of rotational kinetic energy could prove to be disastrous for the spacecraft and the payload¹. Any transverse rates present during spin stabilization will cause the spacecraft wobble about its spin axis at a certain angle. The angle at which it wobbles (or nutates) relative to the spin angle is denoted as the nutation angle^{2,7}. For the ideal flight this angle would be relatively small and constant. In actual flight tests, small transverse rates cause the propellant sloshing motion to interact with the nutation causing a growth in the nutation angle (nutation growth rate). If this nutation angle growth is at too great a rate, it may lead to premature depletion of attitude control propellant, or even worse, as seen in the ATS-5 mission launched in 1969, it may lead to a complete loss of control of the vehicle^{2,3}.

Using a software package called ANSYS FLUENT, a model was created to simulate the sloshing motion of the propellant. This finite volume solver uses a technique called the Volume of Fluid (VOF) to model the interaction between two fluids^{4,5}. This VOF technique uses a simple continuity equation for the volume fraction in each cell.

¹ Graduate Student, Department of Aerospace Engineering, AIAA Student Member

² Professor, Department of Mechanical Engineering, AIAA Associate Fellow

³ Graduate Student, Department of Aerospace Engineering, AIAA Student Member

⁴ Controls Analyst, NASA Launch Services Program

The main idea behind this continuity equation is to track where the two fluids are. For example, if a particular cell has a volume fraction of one, it is full of propellant. If a different cell has a volume fraction of zero, it contains no propellant and therefore contains air. The interface between these two fluids is tracked by the cells with a volume of fluid value between one and zero. This method is basically a way to track mass (of both fluids) as it shifts around inside the computational domain. Using these equations, one can predict the behavior of the sloshing fluid and calculate the forces, pressure gradients, and velocity field for the entire system as a function of time⁵.

The information acquired from the CFD model will be compared to several test scenarios that have been studied in the laboratory in order to verify the CFD results. Once the results have been experimentally verified and there is significant confidence in the values calculated by the CFD technique, it will be applied to various scenarios such as variable gravitational conditions, larger tanks, different shaped tanks, and more viscous liquids. Ultimately, the model will be modified to include tanks with propellant management devices such as diaphragms and baffles.

Figure 1 illustrates the integration of the CFD model into the current fuel slosh research being conducted at ERAU. Currently, the parameter estimation process requires data from experimental results and other simple models. This parameter estimation process will produce values to be used in the initial spacecraft design. The new CFD model will serve as source of data that may be used to verify the experimental results. Ultimately, the CFD model will be used to obtain “experimental type” data for scenarios that are not easily reproduced in the laboratory.

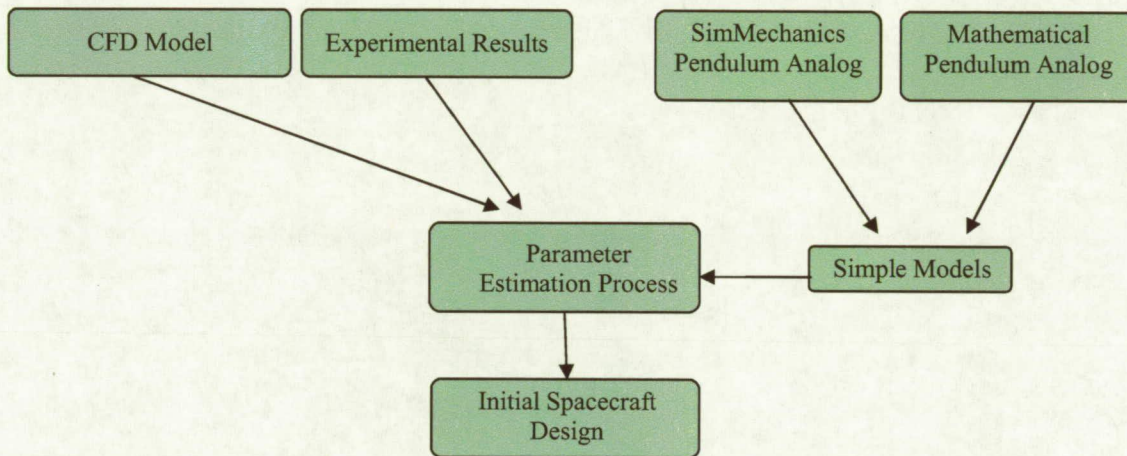

Figure 1. Fuel Slosh Research Flow Chart

II. Experimental Methodology

Seen in Fig. 2, the fuel slosh experimental setup at Embry Riddle Aeronautical University consists of three main parts; the tank, transducer, and linear actuator. The tank is an 8” spherical tank that is suspended by three cables. This allows the tank to freely sway back and forth. A spherical tank was chosen in order to maintain symmetry and simplify the model. The next part of the experimental setup is the force transducer. This force transducer is used to measure the amplitude of the reaction force due to the sloshing fuel. The final component of the experimental setup is the linear actuator. This state-of-the-art linear actuator is used to excite the tank in order to initiate fluid slosh.

For this experimental setup the liquid used in the tank is water. This was chosen because the density and viscosity of water is very similar to that of Hydrazine, a commonly used propellant. The high level of toxicity and chemical instability of hydrazine makes it a very dangerous substance to work with. The fill level of the fluid inside the tank was 60%. This was used because previous studies have shown that the largest slosh force for a spherical tank will be experienced at this fill level¹.

The effect of energy dissipation in sloshing fuel is best illustrated by exciting the tank with a “sudden push” and quickly bringing it to a stop. This causes the fluid to begin sloshing and slowly damp out. The damping effect of the fluid is caused by the fact that the fluid in the tank is not inviscid. The viscous nature of the fluid causes an energy dissipation that will eventually bring the fluid to rest. For water, the maximum amplitude of the reaction force decreases over time. This damping is one of the most important effects that the CFD model must replicate in order to validate the fuel slosh behavior because it is through this damping that energy is transferred. Another

important effect that the CFD model must replicate is the slosh frequency. When the tank is given the initial push the fluid naturally oscillates at a natural frequency. Both of these effects must be replicated by the CFD model.

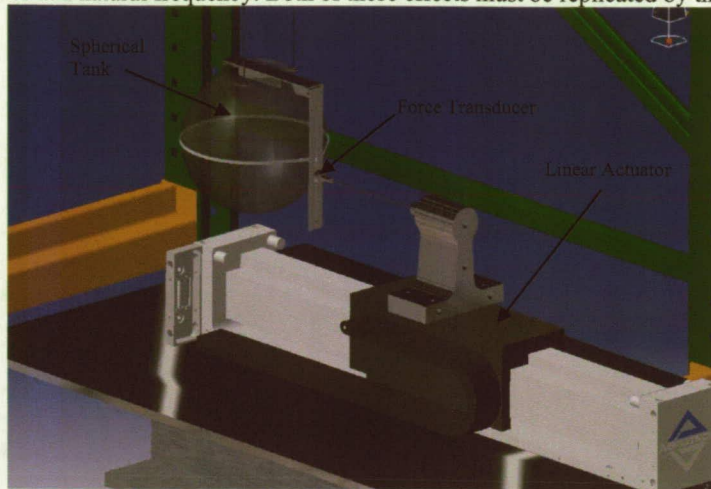

Figure 2. Experimental Set-up⁶

Figure 3 shows an example of what the experimental data looks like. The force that is being measured by the transducer is the force in the direction of excitation. As expected, the force response should be a damped sine wave. This force data is acquired by using a custom designed LabView data acquisition system⁸. This data acquisition system is capable of simultaneously monitoring the reading from the force transducer and the position of the linear actuator.

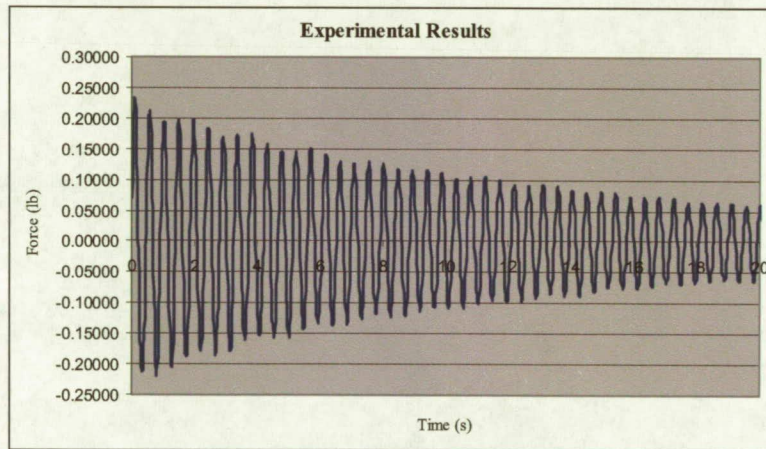

Figure 3. Raw Experimental Data

III. CFD Model

A. Computational Domain

The computational domain for the model is comprised of the spherical tank with an opening at the top for filling. The same dimensions were used in the CFD model as in the actual test tank. Gridgen was used to create the mesh⁹. This tetrahedral mesh was then imported into ANSYS Fluent and converted into a polyhedral mesh. Since ANSYS Fluent uses a finite volume method for solving the flow equations, this polyhedral conversion greatly reduces the number of computational cells while still maintaining a high level of accuracy. The polyhedral conversion also helps with convergence of the solution. As seen in Fig. 4, the mesh used had most cells clustered near the walls of the tank. This was necessary in order to resolve the viscous effects at the wall that contribute to the damping rate.

The boundary conditions for this model are straight forward. The walls of the tank are treated as viscous walls with a no slip boundary condition. This may seem counterintuitive in that a no slip condition may keep it from sloshing at all, but the fact that the VOF equations are actively tracking the interface between the water and air allow the sloshing water to “climb” up the walls over time. The boundary condition used at the open top was a pressure inlet. This pressure inlet boundary condition only requires a pressure to be specified and held constant. Since in the actual experiment this is exposed to the atmosphere, a pressure of 1atm. was specified for this boundary.

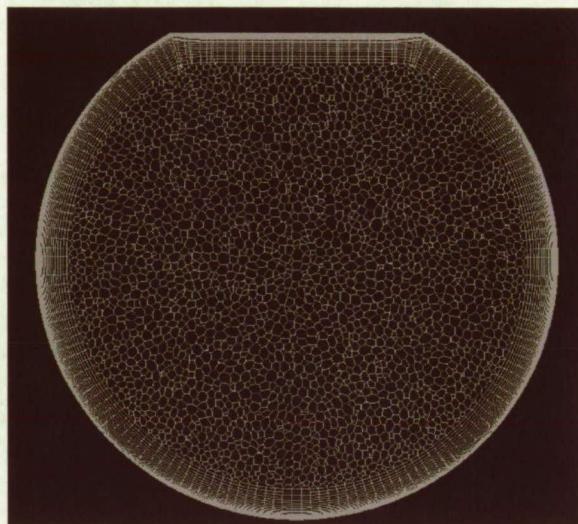

Figure 4. Computational Domain

B. Initial Conditions

The initial conditions for the model are based on the experiment. Just as in the laboratory experiment, the fluid used for the model was water. This was done in order to attempt to replicate the experimental conditions as completely as possible. Also, for the same reason described before, the fill level was maintained at 60%. In this 8” spherical tank, 60% fill level translates to about 2.6 liters of water.

In order to simulate the initial push given to the tank in the experimental setup, the liquid in the tank is initialized with a small horizontal (x) velocity of 0.1 m/s. This will allow the liquid in the tank to begin oscillating and eventually die out. The expected frequency is to be around 2 Hz. so the models were set to run for 10 seconds real time at a time-step size of 0.01 s. Even though this time-step seems a bit large, the polyhedral mesh and second order spatial accuracy allowed the solution to converge relatively quickly.

C. Solver Parameters

As discussed earlier, ANSYS Fluent finite volume solver was used for the CFD model. The specific model used was a 3D, Pressure based, implicit solver. This particular solver was determined to be (by trial and error) the fastest converging model that produced accurate results. The model is second order accurate in space and first order accurate in time. Due to the time dependant nature of the problem, the unsteady formulations of the equations are applied. This allows for a complete solution over time which is needed to extract parameters such as frequency and damping rate. For the VOF free surface tracking discretization, the geo-reconstruct method was applied. This method applies a linear approximation for the cells that contain the free surface interface in order to track it over time.

A variety of turbulence models were used but in the end, the best results were yielded without the use of a turbulence model. The low amplitude of slosh and lack of breaking waves meant that the flow was relatively laminar. When the turbulence models were used, the damping was greatly increased giving larger than expected damping rates. An interesting note is that the values for the frequency did not seem to change with the different turbulence models. For these reasons the viscous formulation assumes laminar flow.

IV. Results

The results of the CFD model show a strong correlation to the experimental results. Not only does the model accurately predict the slosh frequency and damping rate, it also allows one to probe inside the fluid as it sloshes, without disturbing the natural flow of the system. This is very important if one is to understand the dynamics behind fuel slosh.

A. Frequency

The frequency at which the propellant sloshes around inside the tank is a function of gravitational force, fluid fill level, and tank geometry. For this reason it is important to design a spacecraft that does not have any resonant frequencies in the range of expected frequencies for each tank. A resonant coupling can cause the slosh forces to greatly amplify and may create problems with the control system or nutation rate which can be dangerous for the spacecraft and any payload.

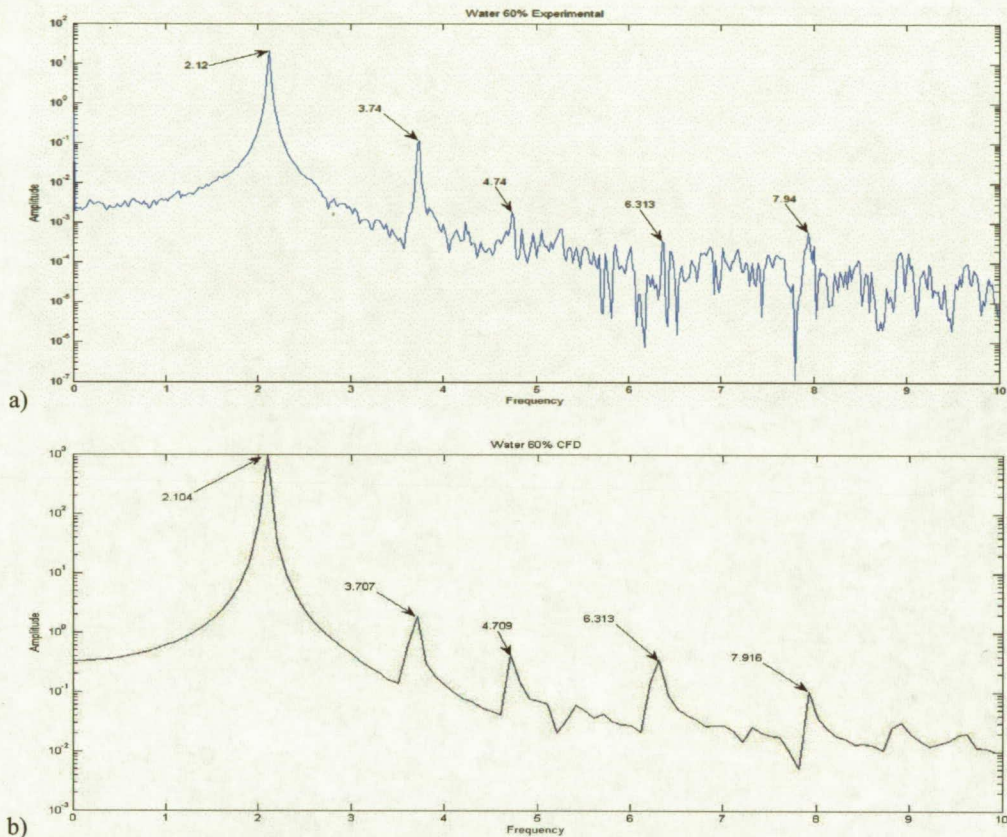

Figure 5. Fourier Transforms for Slosh Frequencies
a) Fourier Transform of Experimental data. b) Fourier Transform of CFD model

By taking the Fourier transform of both the experimental and CFD model data it is clear that the CFD model accurately predicts not only the primary slosh mode but also several higher order modes. It is interesting to note that the results from the CFD model create a cleaner looking Fourier transform than the experimental data. This is due to the fact that the experimental setup is not in a perfect environment. Since the CFD model is purely computational, the results are not influenced by external noise such as vibrations in the support cables and small amplitude excitation in the off axis direction. Overall, the frequency predictions made by the CFD model are within 1% of the experimental values

B. Damping Rate

The next parameter of interest is the damping rate. The damping rate calculation is done by normalizing the peak values for the damped signal and fitting the points to an exponential curve. An example of this is illustrated in

Fig. 6. The peak values from the raw data shown in Fig. 3 are normalized and then fit to the exponential curve. In this particular example, the damping rate is 0.06564.

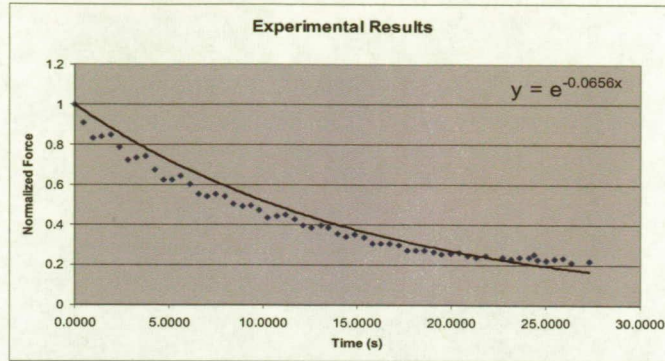

Figure 6. Experimental Damping Rate Calculation

The data from the experimental setup is a force in a specific direction. In order to replicate this in the CFD model, a non-dimensional force coefficient in the direction of excitation is plotted and then subjected to the same analysis as the experimental data. The following table compares the values calculated from the experimental results with the values calculated by the CFD model. The values for the damping rate agree to within less than 1% for the experimental results and CFD model.

Table 1. Damping Rate

	Damping Rate	% error
Experimental Results	0.06564	N/A
CFD Model	0.06557	0.11

C. Propellant Slosh Dynamics

In addition to providing accurate information regarding the damping rate and slosh frequency, the model yields interesting information regarding the dynamics behind fuel slosh as seen in Fig. 7.

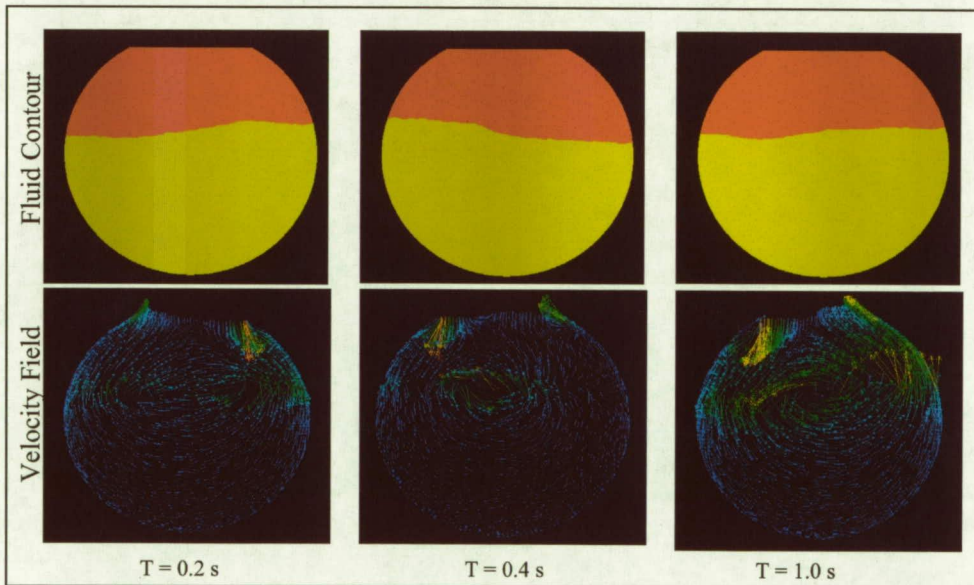

Figure 7. Fluid Contour and Velocity Vector Field at 0.2, 0.4, and 1.0 s.

The parameter estimation process is essentially a pendulum analog model of the fuel slosh. This pendulum analog illustrated in Fig. 8 essentially splits the sloshing propellant into two parts. One part is a larger fixed mass which models the portion of the propellant that is relatively stationary at the bottom. The smaller "slosh mass" is suspended like a pendulum and used to represent the portion which is actually doing the sloshing. This assumption that the slosh mass is relatively smaller than the fixed mass is confirmed by the CFD model. It is clear from the velocity vector field plots that the higher velocities are located near the free surface interface.

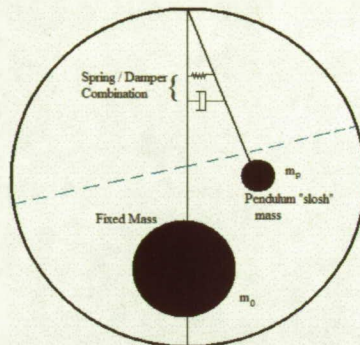

Figure 8. Pendulum Analog Model

V. Conclusion

New advances in the field of computational fluid dynamics have allowed engineers and scientists to use it as a tool for studying complex problems like fuel slosh. This particular model was able to provide accurate predictions of both the frequency and damping rate of sloshing water in a small spherical tank, while also lending insight into the dynamics behind fuel slosh. Several simplifications such as small amplitude slosh and a uniform spherical tank with no propellant management devices (PMD) have made this initial study successful. Future propellant slosh studies must seek new technologies and modeling methods to model more complex scenarios such as slosh in tanks with PMD's. One such new technology that may prove essential in modeling tanks with PMD's is fluid/structure interaction. By coupling a finite element structural code with a CFD code it is may be possible to create a model of a tank with a diaphragm, getting us one step closer to a full model for a real flight tank.

Acknowledgments

The authors would like to thank the Launch Services Program at NASA Kennedy Space Center and the Southwest Research Institute for their continuous help and support for this project. Special thanks go to the fellowship offered by the NASA Graduate Student Researchers Project (GSRP) that makes this study possible. Thanks also go to Keith Schlee and Dillon Sances for their continued interest in this research.

References

- [1] Weihs, D., and Dodge, F.T., *Liquid Motions in Nonaxisymmetric, Partially Filled Containers Rotating at Zero Gravity*, AIAA Journal of Spacecraft and Rockets, Vol. 28 1991.
- [2] Dodge, F.T., *The New Dynamic Behavior of Liquids in Moving Containers*, Southwest Research Institute, Technical Report, San Antonio, Texas.
- [3] Schlee, K. Gangadharan, S.N., Ristow, J., *Advanced Method to Estimate Fuel Slosh Simulation Parameters*, 41st AIAA Joint Propulsion Conference, 2005.
- [4] FLUENT Software Version 6.2.16, © 2004 Fluent Inc.
- [5] Hirt, C.W. and Nichols, B.D., *Volume of Fluid (VOF) Method for the Dynamics of Free Boundaries*, Journal of Computational Physics 39, 201, 1981.
- [6] Chatman, Y. Gangadharan, S.N. Marsell, B., *Mechanical Analog Approach to Parameter Estimation of Lateral Spacecraft Fuel Slosh*, 49th AIAA/ASME/ASCE/AHS/ASC Structures, Structural Dynamics, and Materials Conference, 2008.
- [7] Hubert, C., *Behavior of Spinning Space Vehicles with Onboard Liquids*, Hubert Astronautics, 2nd Edition August 2008
- [8] LabView Version 7
- [9] Gridgen 2007-2008 Pointwise, Inc.