

February 16, 2007

Real-time Wireless Data Acquisition System

Abstract

Current and future aerospace requirements demand the creation of a new breed of sensing devices, with emphasis on reduced weight, power consumption, and physical size. This new generation of sensors must possess a high degree of intelligence to provide critical data efficiently and in real-time. Intelligence will include self-calibration, self-health assessment, and pre-processing of raw data at the sensor level. Most of these features are already incorporated in the Wireless Sensors Network (SensorNet™), developed by the Instrumentation Group at Kennedy Space Center (KSC).

A system based on the SensorNet™ architecture consists of data collection point(s) called Central Stations (CS) and intelligent sensors called Remote Stations (RS) where one or more CSs can be accommodated depending on the specific application. The CS's major function is to establish communications with the Remote Stations and to poll each RS for data and health information. The CS also collects, stores and distributes these data to the appropriate systems requiring the information. The system has the ability to perform point-to-point, multi-point and relay mode communications with an autonomous self-diagnosis of each communications link. Upon detection of a communication failure, the system automatically reconfigures to establish new communication paths. These communication paths are automatically and autonomously selected as the best paths by the system based on the existing operating environment.

The data acquisition system currently under development at KSC consists of the SensorNet™ wireless sensors as the remote stations and the central station called the Radio Frequency Health Node (RFHN). The RFHN is the central station which remotely communicates with the SensorNet™ sensors to control them and to receive data. The system's salient feature is the ability to provide deterministic sensor data with accurate time stamps for both time critical and non-time critical applications. Current wireless standards such as Zigbee™ and Bluetooth® do not have these capabilities and can not meet the needs that are provided by the SensorNet technology. Additionally, the system has the ability to automatically reconfigure the wireless communication link to a secondary frequency if interference is encountered and can autonomously search for a sensor that was perceived to be lost using the relay capabilities of the sensors and the secondary frequency. The RFHN and the SensorNet designs are based on modular architectures that allow for future increases in capability and the ability to expand or upgrade with relative ease. The RFHN and SensorNet sensors can also perform data processing which forms a distributed processing architecture allowing the system to pass along information rather than just sending "raw data points" to the next higher level system. With a relatively small size, weight and power consumption, this system has the potential for both spacecraft and aircraft applications as well as ground applications that require time critical data.

The RFHN hardware is based on the PC-104+ industry standard form factor and consists of COTS boards and a custom transceiver board. The operating system is based on the VxWorks Real-Time Operating System (RTOS) and the software is written in C. The RFHN development is not complete with still some software development required before the system is fully functional.

February 16, 2007

The Remote Sensor hardware is based on a custom miniature form factor that allows plug-in modules for the different type sensors. Remote stations using SensorNet have been developed for different sensing technologies such as resistive temperature device, silicon diode, strain, pressure, and hydrogen leak detection.

POC:

Emilio Valencia

NASA, Kennedy Space Center

Mail Code: KT-C

J.Emilio.Valencia@nasa.gov

REAL-TIME WIRELESS DATA ACQUISITION SYSTEM

Emilio Valencia
NASA Kennedy Space Center
Kennedy Space Center, FL 32899
(321)861-9074

J.Emilio.Valencia@nasa.gov

Angel Lucena
NASA Kennedy Space Center
Kennedy Space Center, FL 32899
(321)867-6743

Angel.R.Lucena@nasa.gov

Jose Perotti
NASA Kennedy Space Center
Kennedy Space Center, FL 32899
(321)867-6746

Jose.M.Perotti@nasa.gov

Carlos Mata, Ph.D.
NASA Kennedy Space Center
Kennedy Space Center, FL 32899
(321)867-6964

Carlos.T.Mata@nasa.gov

Within the current and future requirements for advanced data acquisition systems lies the ability to significantly improve the reliability, the cost-benefits, and the safety for future space exploration and air travel. New data acquisition subsystem designs are needed that provide embedded intelligence and pass on information to the next higher level subsystem/system rather than raw sensor data.

These advanced data acquisition systems with their current and future aerospace requirements demand the creation of a new breed of sensing devices, with emphasis on reduced weight, power consumption, and physical size. This new generation of sensors must possess a high degree of intelligence to provide critical data efficiently and in real-time. Intelligence will include self-calibration, self-health assessment, and pre-processing of raw data at the sensor level. Most of these features are already incorporated in the Sensors Network (SensorNet) technology developed at the Kennedy Space Center (KSC). Additionally, due to technological advancements, it is possible and more advantageous to establish a wireless communication link with sensors. Wireless sensors substantially improve launch systems, require significantly less labor to install and result in an overall reduced installed weight. Wireless sensors replacing traditional sensors will yield significant advantages in cost, processing time and increased responsiveness of aerospace systems. And these sensors must be low-power,

provide highly reliable wireless communication and incorporate smart sensor technology.

System Description

Generally speaking, the wireless data acquisition system can be described as a network architecture containing data collection points, called Central Stations (CS). The network can have one or more data collection points depending on the specific application. The CS functions are to establish communication with the intelligent sensors, called Remote Stations (RS), to poll the remote stations for data and health information, and to collect, store and forward this data to the next higher level system.

The wireless data acquisition system called the Radio Frequency Health Node(RFHN)/SensorNet (RSN) currently under development at KSC consists of a system based on the SensorNet (refer to section 7) technology developed at KSC. The RFHN is the central station and its major function is to establish communications with the SensorNet remote stations and to poll each remote station for data and health information. In addition, the CS collects, stores and distributes these data to the appropriate systems requiring the information. The system has the ability to perform point-to-point, multi-point and relay mode communications with an autonomous self-diagnosis of each communications link. Upon detection of a communication failure, the system automatically reconfigures to establish new communication paths. These communication paths are automatically and autonomously

selected as the best paths by the system based on the existing operating environment.

The KSC implementation uses the Radio Frequency Health Node (RFHN) as the Central Station and the SensorNet wireless sensors as the remote stations. This system's salient feature is the ability to provide real time, deterministic sensor data with accurate time stamps for both time critical and non-time critical applications. Current wireless standards such as Zigbee™ and Bluetooth® do not provide these capabilities and can not meet the performance requirements provided by the SensorNet technology.

The RSN system has the ability to automatically reconfigure the wireless communication link to a secondary frequency if interference is encountered and can autonomously search for a sensor that was perceived to be lost using the relay capabilities of the sensors and the secondary frequency. This is achieved by schemes that allow modules to reconfigure themselves automatically to work as relay stations (increasing the overall range of the wireless systems while using minimum power). The frequency-switching scheme used to overcome RF communication problems has been patented by NASA that was awarded to the ASRC and NASA developers of the technology. The RSN component designs are based on modular architectures to minimize system impacts when future expansion, upgrade, and/or increase in capability is required. Additionally, the RFHN and SensorNet sensors can perform data processing forming a distributed processing architecture that allows the system to pass along information rather than just sending “raw data points” to the next higher level system. With relatively small size, weight and power consumption, this system has the potential for aerospace as well as ground applications including applications with time critical requirements.

The envisioned operational system will be composed of smart, fault-tolerant, miniature wireless modules capable of providing sensor excitation and signal conditioning for a full suite of sensors (temperature, pressure, strain gages, gas detection, etc.). Smart power management, autonomous operation, deterministic communication protocols, embedded intelligence, self-health assessment, and self-reconfiguration capabilities will guarantee fault-tolerant operation. The design goals for such an operational include the following:

1. High Reliability/Safety: Autocalibration (short-term drift), in situ calibration (long-term drift), self-healing (fault-tolerant, overcome RF interferences, and/or upset components), auto-reconfiguration, and embedded intelligence for failure detection and autonomous operation (using the “wireless bus” to evaluate their surroundings to perform corrective actions in a proactive manner).

2. Low Installation, Operation, and Maintenance Costs: A modular, self-powered, autonomous, remotely reconfigurable system resulting in the lowest possible maintenance. The system's modular architecture provides enough flexibility for remote reconfiguration adapting for new roles when required (in situ or remotely commanded). These capabilities will result in major reductions in system complexity and deployment, operation, and maintenance costs.

3. System Integration: A drop-and-operate technology will be developed, in conjunction with other system designs, to provide seamless integration, minimizing integration complexity and cost.

4. Robustness: Packaging designs will use state-of-the-art, lightweight materials and include protection from radiation, extreme temperatures and other harsh environments.

RFHN Description

The RFHN is a central station used to acquire instrumentation data from wireless sensors that is currently under development at KSC. The RFHN provides a real-time command and data interface to wireless sensors and serves as a single point to interface with multiple sensors of multiple types. The RFHN receives the sensor data (via a wireless communication link), performs data processing and storage (if required), and then forwards the sensor information via a standard interface where data processing can include preprocessing of data, data fusion, trending, etc. The system has the flexibility to be configured as required for each application with a different number of sensors and sensor types.

The primary functions of the RFHN are network controller, data collection and forwarding data. Some characteristics are:

- Perform sensor network data collection, storage and/or forwarding

- Contain data polling schedules and Remote Stations' unique identification tables in the sensor network
- Contain remote stations calibrations curves and engineering unit conversions functions*
- Perform data trending and historical archiving of sensor data and remote station health status information for each of remote stations*
- Contain software algorithms to support a) automated data polling operation, b) manually requested data polling and c) troubleshooting capabilities

*These characteristics can be embedded at the remote station level if desired.

The RFHN hardware is a modular, processor based design that is both physically and electrically expandable. The standard board interface and stacking frame of the PC/104+ standard allow the module to expand as necessary. This provides for individually removable modules such as the power supply, processor, memory, command interface, data interface, and wireless transceiver interface. The operating system is the VxWorks Real-Time Operating System (RTOS) with application code written in C. The RFHN consists of a core module and a transceiver module. The core module provides the generic functions and the transceiver module provides the interface to the wireless sensors. The core module provides central processing unit (CPU), data storage, power, and a pulse code modulation (PCM) data output used to forward the data. The transceiver module provides the wireless link and protocol required to communicate with the wireless sensors.

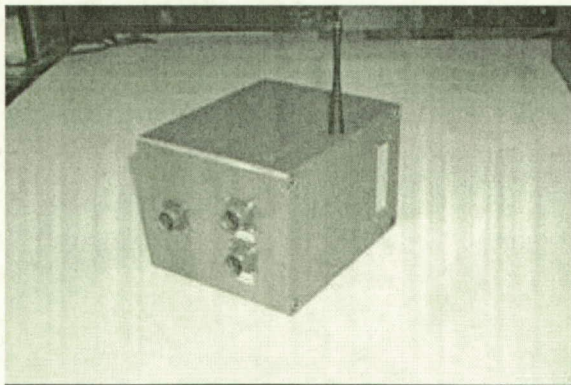

Figure 1 - RF Health Node

RFHN features:

- Autonomous command and control of the wireless sensors
- Receive and process data from wireless sensors in real-time
- Modular design minimizes cost to incorporate new wireless sensor technologies
- Ethernet interface for command and data
- PCM interface for data output
- On-board data storage allows data to be recorded
- Passively cooled unit
- Dimensions: 5.6" x 7.5" x 4.7",
- Weight: approx 6 lbs
- Power: 28VDC at 1 amp
- Operating temperature: 0°C to 63°C

The RFHN has been designed, implemented and flight tested in a relevant environment. The results of the flight test are provided in section 9, WSMR Test Flight.

SensorNet Remote Station Description

Current and future requirements of aerospace sensors and transducers demand the design and development of a new family of sensing devices, with emphasis on reduced weight, power consumption, and physical size. This new generation of sensors and transducers will possess a certain degree of intelligence in order to provide the end user with critical data in a more rapid and efficient manner, such as self-calibration, self-health assessment, and pre-processing of raw data at the sensor level. Communication between networks of traditional or next generation sensors can be accomplished by a Wireless Sensors Network, developed at KSC, consisting of hardware, software, as well as a novel communication protocol.

The SensorNet wireless sensors (SWS) are sensors with an embedded remote station capability which have been developed at KSC.

These sensors have been implemented using different sensing technologies such as resistive temperature device, silicon diode, strain, pressure, and hydrogen leak detection. SWS are self contained and provide the interface to the raw sensor, signal conditioning, data acquisition, data processing and data distribution to other elements of the network. Additionally, SWS can also be used as information relay stations and have no dedicated sensing elements connected to them. These information relay stations are utilized when the distance between the CS and the RS is outside the RF transmission range or when interferences in the area prevent direct communication.

SensorNet incorporates advancements in two key areas of technology. The first advancement in technology is the smart sensor. KSC has developed sensors that use different techniques to verify health status, perform auto-configuration, self-calibrate, and determine the validity of the data. This technology is an improvement over traditional sensors when comparing operational and maintenance requirements and can reduce erroneous data transmissions. Wireless communication is the second technology advancement. KSC has developed fault-tolerant sensors that use communication techniques enabling reliable RF transmission even in difficult environments. Wireless sensors require significantly less labor to install and result in a reduced installed weight. The development of a suite of wireless sensors to replace traditional sensors will yield significant cost and processing time advantages. The SensorNet hardware is based on a custom miniature form factor that allows plug-in modules for the different type sensors.

SensorNet Remote Station Key Features

The key features for a SensorNet Remote Station are as follows:

- Frequency 916 MHz
- Bandwidth 50 KHz
- RF power output: 1 milliwatt
- Dimensions: 1" x 3" x 2" (approx)
- Weight: 3.2 ozs

SensorNet Remote Station Hardware Description

Since the SensorNet hardware is based on a modular architecture, a SensorNet RS can be built with between one to four modules depending on the required capabilities for the specific application. The hardware modules are described in the following paragraphs.

1. RF Core Module

The first module is called the "RF Core Module". It contains the hardware and firmware required to transmit and receive information through the network. It contains a commercial-off-the-shelf transceiver; either tuned to a carrier frequency of 433 MHz or 918 MHz. A dedicated microprocessor executes the embedded software algorithms to establish and assure network communication. When a specific application is simple enough, this module can also provide an analog input (0 to 3.3 VDC) or RS232 digital communication to the sensor. In that case, no other sensor interface module is required.

The selected transceiver is a low power transceiver, with an RF output power of 10 milliwatts. It is a spread spectrum transceiver with up to 32 frequency steps. Our project does not use it as a spread spectrum device, but utilizes the benefits of the 32-frequency steps in the design. It operates at 3.3 VDC and current consumption is around 15 mA in receive mode and around 25 mA in transmit mode (at 10 mW output power). Supporting microprocessor and miscellaneous hardware does not add significant to the power consumption. The total maximum current consumption of the module is about 30 mA at 3.3 VDC (in transmit mode) with only few tens of micro-amps in idle mode. The power consumption depends on the specific application usage determined by the Power Management Board described below.

2. Power Management Module

The power management module is designed to provide power to the different modules connected in the RS and provides battery voltage monitoring and health status. Furthermore, it contains the "Power ON, Power OFF" scheduling for the different modules in the RS.

The module contains a number of LDO (low Drop-out) series regulators, dedicated to each of the different modules that contain the analog switching required to power up/power down the different modules. A very low power microprocessor contains the embedded software algorithm to monitor the battery voltage, battery usage and low voltage conditions. It also contains

embedded software, specific to the application being implemented, to conserve and extend battery life.

3. Sensor Interface Module

The sensor interface module is designed to provide sensor excitation, sensor signal conditioning, data acquisition and data conversion as well as any other unique need that the raw sensor may require.

This module is specific to the application as well as to the sensor being connected to the module. The designed approach can be tailored to interface to most of the sensing technologies existing in the market at the present time. The sensor interface module may or may not have a dedicated processor. This decision is made based on the requirements of the specific application.

4. Embedded Knowledge Module

The embedded knowledge module is the most application specific module of the system. It is designed to perform more complex operations. Among these operations, the system could perform measurement trending, high and low limits alarms, or more involved calculations like FFT transforms, etc. The module is designed to ultimately include embedded knowledge capable of performing measurement health checks as well as process health checks. Using this concept, it has been demonstrated that the system is capable to differentiate between instrumentation failures and process measurements indicating that process is “out of control”. The module is presently designed around a Digital Signal Processor (DSP) to perform these functions.

SensorNet Remote Station Software Description

Each hardware module has its unique embedded software algorithms to control their assigned operation. These software algorithms are executed by dedicated microprocessors in each module. A high level description of the software algorithms is provided in the list below:

- The power management module contains software algorithms to monitor battery health status and to maximize battery life. The Power Management software controls the “ON/OFF” power cycles for the other modules present in the remote station.
- The analog interface and embedded knowledge modules contain software algorithms

specific to the application or sensor technology being monitored.

- The RF core module contains software algorithms to assure data communication integrity and availability. It also contains the “Lost Station” software algorithm to overcome communication interferences.

Wireless Communication Protocol

Wireless SensorNet contains smart software algorithms to automatically and autonomously reconfigure from a traditional protocol configuration (point-to-point communication) to a relay network protocol configuration (using the “Lost Station” algorithms) upon communication failure detection at a specific Remote Station. The relay network communication protocol is not reduced to a single depth (only one relay station involved in the process) in the network, but could configure itself to increase layers of communication depth (several relay stations involved in the process). Since the network is constantly checking its communication’s health, the system can automatically reconfigure back to a traditional communication protocol upon restoring normal communication with Remote Stations. The “Lost Stations” algorithm is embedded in both the Central Station and the Remote Stations. Therefore, depending on the specific application, a larger portion of the code can be located in the Remote Stations instead of the Central Station or vice versa. Finally, the Central Station contains software to perform a notification function. The system is designed to forward SensorNet information that includes functional and health check data. Levels of alert are used to identify problems or failures with “True Lost Stations” (Remote stations with no communication link to the Central Station) and provide a notification of the event.

The Central Station contains software algorithms to assure data communication integrity and availability. Also, the “Lost Station” software algorithm is the part of the Central Station that overcomes communication interferences and is described briefly in the following list:

- The Network starts in a nominal master/remote (point-to-point) protocol configuration.
- The CS sequentially and automatically scans all the RS according to a predetermined schedule.

- When a communication failure is detected between the CS and a RS, the CS autonomously commands all other remote stations to locate and attempt to communicate with the lost RS.
- When one of the RS establishes communication with the lost station, this RS is assigned to establish a receive/transmit communication link with the "Lost Station" on an alternate frequency.
- Communication with the "Lost Station" is relayed back and forth between the CS and the "Lost Station" through the assigned RS.

ISHM Building Block

The technology presented in this paper is driven by the aerospace industry to increase safety, reduce maintenance costs and the need to implement Integrated Systems Health Management (ISHM) technologies. The RSN system's capability to perform data processing in the CS and the RS allows the processing load to be distributed within the entire data acquisition system and support such technologies as the Integrated Systems Health Management (ISHM). The components of the RSN system are therefore the building blocks for ISHM systems.

NASA-KSC and ASRC are collaborating with Stennis Space Center and Marshall Space Flight Center to develop an Integrated Health Management System for the new Exploration Program. We were picked to develop sensor technology for this system. Many of these requirements will be similar to those required for Operationally Responsive Space Launch. Satellite instrumentation will share the extended temperature range requirements, the limited power budget, the self-calibration, and zero-maintenance requirements.

Operational Issues

Depending on the system's installed environment, different operational issues surface and pose challenges to the deployment of wireless data acquisition systems. When using wireless communication systems in an electrically hazardous launch environment, the system must use very low power levels. For example, KSC has implemented wireless technology with sensors

mounted directly on the Shuttle Solid Rocket Boosters. Also, in another type of environment dealing with a ground support application, KSC developed a wireless daisy chain design where sensors relayed the data to limit the RF output power requirements. This daisy chain technique may be applied to launch-based systems.

Other issues arise such as the importance to verify the integrity of the payload while processing a quick turnaround for launch scrubs. For this issue, wireless communication utilizing smart sensors ensure reliable, real-time information, requires minimal time to install, and is not dependent upon existing launch hardware configurations. Wireless communication enables data from the payload to be integrated without wiring fabrication requirements or the inclusion of an umbilical that must be separated at the time of deployment. Extended temperature range, radiation exposure protection, maximum miniaturization, a life expectancy matched to the payload, and an onboard master station for external communication after deployment are specialized requirements that must be addressed for satellite applications. KSC has developed wireless sensors that have an expected life of 10 years using two D-cell batteries even without an optimized power management scheme. Additionally, KSC has identified a possible new moldable material for sensor packaging that has very favorable thermal, strength, and weight characteristics.

WSMR Test Flight

The RFHN was flight tested on a sounding rocket launched from the White Sands Missile Range (WSMR) on September 23, 2004. The multi-Center NASA project team included industry and personnel from Kennedy Space Center (KSC), Johnson Space Center (JSC), Wallops Flight Facility (WFF), WSMR, the NASA Sounding Rocket Operations Contract (NSROC), the University-Affiliated Spaceport Technology Development Contract (USTDC), and Invocon, Inc. The actual flight was managed by WFF with support from NSROC, U.S. Army and Navy personnel. The test was used to evaluate the reliability of the wireless sensor system in the flight environment, to increase the technology readiness level of the wireless data acquisition system for the eventual use on future aerospace systems, and to ensure that such a system is a viable method to implement future data acquisition systems.

The system consisted of a data receiving unit called the RFHN, and data transmitting units called the micro-wireless sensors. The micro-wireless sensors were designed and developed by Invocon, Inc. through a Small Business Innovative Research (SBIR) contract that included two strain gauges and one temperature sensor. The system uses the unlicensed Instrumentation Scientific Medical (ISM) frequency of 916.5 megahertz (MHz) for wireless communications with a baud rate of 50 Kilo bits per second (Kbps). A block diagram of the system is shown below.

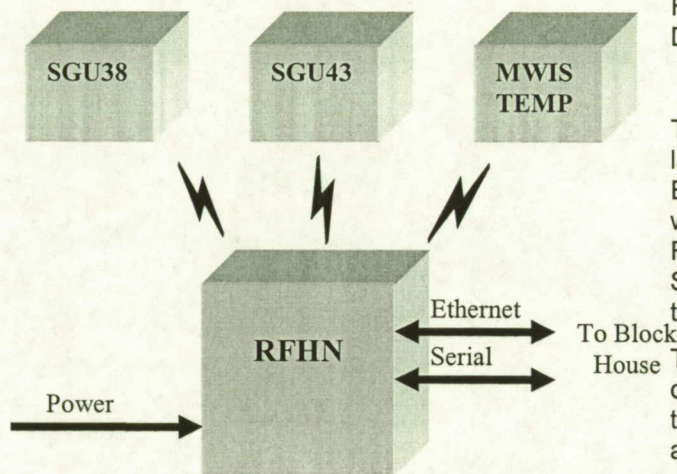

Figure 2 - RFHN Wireless Sensor System Block Diagram

The primary objectives of the flight were to demonstrate the ability of the system to wirelessly transmit and receive data, store the sensor data, and to quantify the reliability of the wireless link during flight. The flight was successful and the objectives were met. The sensors transmitted thousands of packets during the flight. Post flight data analysis showed that the reliability of the wireless link was at least equal to or better than the reliability measured during the ground integration and preflight testing activities. A photo of the RFHN and one of the micro-wireless sensors called the Strain-Gauge Unit (SGU) is shown below.



Figure 3 - RFHN and SGU38 Mounted on the Deck Plate

The RFHN was controlled and configured prior to launch via the umbilical, using the serial and Ethernet interfaces. Prior to launch, the RFHN was placed into an auto mode that allowed the RFHN to autonomously collect data from the SGUs without any additional commanding during the flight.

The autonomous operation of the system was designed to maximize the number of bits transferred wirelessly during the flight in order to achieve the best possible characterization of the wireless link. This maximum number of bits was achieved by performing downloads from the SGU to the RFHN and not performing data acquisitions during flight since the SGUs cannot perform both operations simultaneously. The SGU data acquisition was performed prior to launch to fill the memory which would be downloaded repeatedly during flight. The MWIS temperature sensor does not have a data storage capability therefore, the sensor performed data acquisition and transmission during the flight. Since the data wasn't telemetered down to the ground during the flight, the RFHN stored the data on-board. These data were recovered during the post-flight data dump.

The sensor mounting locations rocket were determined by first temporarily installing the sensors and then performing tests to verify that a good wireless communication link could be established between the RFHN and the sensor. If the wireless link did not provide good communication, then the sensor was placed in a different location until a good location was found.

Test flight Preparations revealed an important aspect of a wireless data acquisition system. This

aspect deals with the wireless sensors' mounting locations and the central station's ability to communicate with all of the installed sensors, regardless of the sensors' locations assuming the sensors are not behind a sealed bulkhead or the like. For this flight, the sensors' final locations were determined by testing the link between the RFHN and the sensors to verify a good wireless communication link before the final mounting location was chosen. The testing was repetitious, time-consuming and would be a huge negative aspect when installing any operational system. Therefore, a wireless data acquisition system should provide the ability to install sensors virtually anywhere in the vehicle and be almost guaranteed a good wireless communication link without having to perform tests to verify the link.

WFF Test Flight

The next testing phase includes interfacing the RFHN with the SensorNet sensors and performing a flight test on board a sounding rocket from the Wallops Flight Facility (WFF). The launch is scheduled for the last quarter in 2007. The new system called the RFHN/SensorNet (RSN) system will measure the reliability of the SensorNet wireless link, determine the ability of the RFHN to communicate with the sensors independent of the sensor's mounting location and increase the technology readiness level of the RSN.

Aircraft Electrical Wiring Issues and Investigations

Spacecraft and aircraft wiring have caused numerous anomalies and failures, one that included a wiring short circuit occurring five seconds into a Space Shuttle launch. In addition, wiring adds significant weight (230 miles of wire per Shuttle, over 100 miles of wires per transport category airplane). Therefore, the reduction and/or elimination of wiring results in a more economical, more reliable air and space travel. The following is a reference to a presentation before the subcommittee in the House of Representatives on September 15, 1999 regarding aging aircraft wiring.*

"Electrical systems are critical to the safe operation of transport category airplanes, and

wiring is used to distribute power and communication signals throughout these systems. Many transport category airplanes contain over 100 miles of wiring. Today, I would like to discuss the Safety Board's efforts to address aircraft wiring issues raised in accident and incident investigations...

Since 1983, the Safety Board has investigated 15 transport category airplane accidents or incidents that involved electrical wiring malfunctions. As a result of those investigations, we have issued 34 safety recommendations regarding electrical wiring malfunctions....

The investigation, conducted by the Transportation Safety Board of Canada (TSB) with participation from the NTSB, revealed that the fire originated near a wire bundle routed below the cabin floor that had been routed with an extremely tight bend, which can crack wiring insulation. Some of the wires in this bundle showed evidence of electrical arcing...."

* [Slides](#) [NTSB Home](#) [News & Events](#)

Summary

The RFHN/SensorNet (RSN) System presented in this paper provides a flexible reconfigurable architecture that could be used in a broad range of applications. It also provides a sensor network with increased reliability; decreased maintainability costs, and assured data availability by autonomously and automatically reconfiguring to overcome communication interferences. The technology described uses wireless communications to interface with sensors and provides solutions to the limitations/disadvantages associated with traditional data acquisition systems using wires.

In addition to the mitigation of safety concerns due to aging of wires, the real-time capability, and addressing maintenance issues with traditional sensors, the RSN architecture inherently provides a reduction in wiring needs, a low cost solution for after market instrumentation, a rapid response to the changing needs of instrumentation data, and a capability to perform data processing at the sensor level.