

Reduced Volume Prototype Spacesuit Water Membrane Evaporator; A Next-Generation Evaporative Cooling System for the Advanced Extravehicular Mobility Unit Portable Life Support System

Janice V. Makinen,¹ Ian Anchondo,² Grant C. Bue,³ Colin Campbell⁴
NASA Johnson Space Center, Houston, Texas, 77058

Aaron Colunga⁵
Jacobs Engineering, Inc., ESCG Houston, Texas, 77058

Development of the Advanced Extravehicular Mobility Unit (AEMU) portable life support subsystem (PLSS) is currently under way at NASA Johnson Space Center. The AEMU PLSS features a new evaporative cooling system, the reduced volume prototype (RVP) spacesuit water membrane evaporator (SWME). The RVP SWME is the third generation of hollow fiber SWME hardware. Like its predecessors, RVP SWME provides nominal crew member and electronics cooling by flowing water through porous hollow fibers. Water vapor escapes through the hollow fiber pores, thereby cooling the liquid water that remains inside of the fibers. This cooled water is then recirculated to remove heat from the crew member and PLSS electronics. Major design improvements, including a 36% reduction in volume, reduced weight, and a more flight-like backpressure valve, facilitate the packaging of RVP SWME in the AEMU PLSS envelope. The development of these evaporative cooling systems will contribute to a more robust and comprehensive AEMU PLSS.

Nomenclature

<i>ACL</i>	=	auxiliary cooling loop
<i>AEMU</i>	=	Advanced Extravehicular Mobility Unit
<i>EVA</i>	=	extravehicular activity
<i>HoFi</i>	=	hollow fiber
<i>Mini-ME</i>	=	mini membrane evaporator
<i>mm</i>	=	millimeter
<i>m²</i>	=	meter squared
<i>PLSS</i>	=	portable life support subsystem
<i>psid</i>	=	pounds per square inch differential
<i>PU</i>	=	polyurethane
<i>RVP</i>	=	reduced volume prototype
<i>SOV</i>	=	secondary oxygen vessel
<i>SWME</i>	=	spacesuit water membrane evaporator
<i>W</i>	=	watt

I. Introduction

NASA is currently developing an advanced extravehicular mobility unit spacesuit portable life support subsystem (PLSS) technology unit that is human-rated for long-duration microgravity or planetary missions, and vacuum or low-pressure environments. A critical component of extravehicular activity (EVA) suits is heat rejection, which cools the crew member and electrical components in the PLSS. The current PLSS uses a sublimator for heat rejection. Whereas the current PLSS sublimator can effectively cool the

crew member and electronics, it has a number of limitations including sensitivity to contaminants and the need for a separate feedwater supply. Because of these limitations, the current PLSS sublimator is certified for only 25 EVAs—critically limiting current EVA capability. Additionally, sublimators do not have the capability of rejecting heat in pressure environments that are above the triple point of water, such as the atmospheric conditions of Mars.

The hollow-fiber (HoFi) spacesuit water membrane evaporator (SWME) has been selected as the heat-rejection technology in the next generation of spacesuits. The HoFi SWME cools circulating water (which acts as the coolant in the system) through in-line evaporation. The water is then circulated through the liquid cooling garment and also to PLSS components. The SWME takes advantage of recent advances in micropore membrane technology to provide robust heat rejection with a high tolerance to contamination. HoFis are thin-walled, porous tubes made from polypropylene that are approximately 300 microns in diameter. This HoFi membrane technology yields a low mass and volume system that is durable and reliable. The HoFi geometry allows a high-membrane surface area to be contained in a compact module; therefore, large volumes can be filtered with low power consumption while using minimal space. The current SWME design has about 14,900 tubes providing approximately 0.6 m² of open pore area, which contributes to SWME's resistance to coolant loop contaminants that will accumulate over the planned 800-hour operational life.

The first sheet membrane SWME prototype, which was designed and tested at NASA Johnson Space Center in 1999, showed promise for the next-generation heat-rejection subsystem.¹ In 2009, a full-scale version of the sheet membrane prototype was built,² together with two full-scale HoFi prototypes (Fig. 1); one with spacers for venting (Gen1 HoFi#2) and one without spacers for venting (Gen1 HoFi#1).³ These three prototypes underwent a series of tests to characterize membrane performance, including determination of the cooling water heat-rejection rate, backpressure results, and contamination sensitivity. In 2010, a new prototype SWME, based on the Gen1 HoFi#1, was created (Gen2). Gen2 is mostly built of plastic and has a flight-like backpressure valve built into the housing (see Fig. 2). After a year of both standalone and integrated PLSS testing, development of a 3rd generation SWME—the reduced volume prototype (RVP) SWME began.

II. Reduced Volume Prototype Design and Development

In 2010, the Gen2 SWME was successfully demonstrated in the AEMU PLSS 1.0 Breadboard. The focus of this test was to investigate the performance and capability of all technology development hardware that will be incorporated in the AEMU PLSS: the SWME, the primary and secondary oxygen regulators, the Rapid Cycle Amine Swingbed, and the fan. While this test incorporated all technology development hardware, these hardware elements were intentionally not packaged in a PLSS-like volume—all hardware was erected on a large rig to facilitate service and to incorporate additional sensors. Following successful demonstration of the PLSS 1.0 Breadboard, planning for a fully packaged, volumetrically accurate PLSS 2.0 began.

To maximize PLSS packaging efficiency, the SWME team began design of a more compact test article. The main goals of the RVP SWME included reducing volume of the test article by 20% without significantly impacting heat rejection performance. The heat rejection requirement for the RVP SWME was set as 700W.

A. Reduced Volume Prototype Spacesuit Water Membrane Evaporator Sizing Analyses

A number of sizing analyses were performed based on Gen2 SWME testing results:

1. Fiber Count

During Gen2 SWME testing, the team assessed the heat rejection of two different cartridges. A five-layer, 30-chevron (14,900 fibers total) Gen2 SWME produced 700W of heat rejection at 91kg/hr with a 10°C outlet, whereas a six-layer, 30-chevron (17,900 fibers total) Gen2 SWME produced 892W of heat rejection at 91kg/hr with a 10°C outlet. Based on this improved performance with increased fibers, a six-layer hollow fiber chevron configuration was selected for the RVP SWME

2. Fiber Length

The Gen2 SWME had a total exposed fiber length of 6.5 inches. Based on the RVP SWME heat rejection requirement of 700W at 91kg/hr with a 10°C outlet, it was determined that a six-layer, 30-chevron RVP SWME would only require a total exposed fiber length of 5.1 inches.

3. Vapor Flow Gap Sizing

The Gen2 SWME had a 15.88 mm vapor flow gap around the perimeter of the hollow fiber cartridge to facilitate efficient vapor escape from the Gen2 SWME housing. Circumferential vapor flow pressure drop calculations for RVP SWME indicated a 9 mm vapor flow gap would be sufficient to ensure efficient vapor escape and a vapor pressure differential between the outside and inside of the housing that amounted to less than 10% of the total vapor backpressure (Fig X).

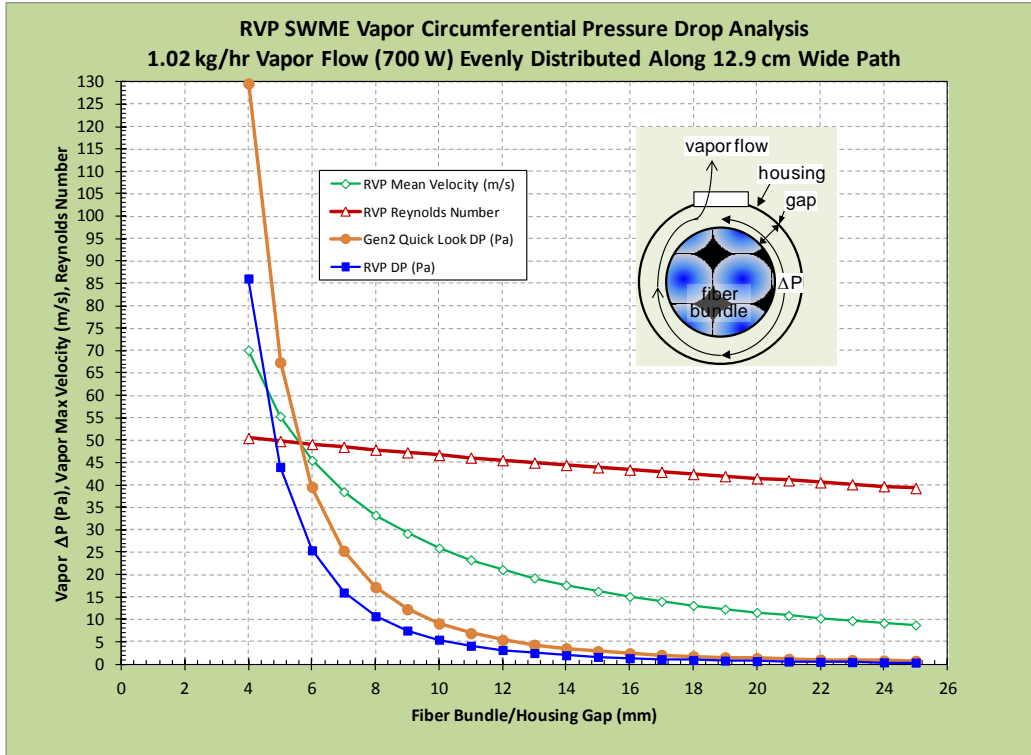

B. Reduced Volume Prototype Spacesuit Water Membrane Evaporator (RVP SWME) Design Overview

Based on the sizing analyses, the team developed an RVP SWME design that would incorporate sufficient fiber length, vapor flow gap, and number of fibers to attain a heat rejection goal of 700W at 91 kg/hr flow rate with a 10°C outlet.

The team elected to stay with the same general design concepts of the Gen2 SWME: a cylindrical envelope with a poppet backpressure valve. Several RVP SWME design elements were novel, including a hollow fiber cartridge bonded directly to the housing with no cage, and the elimination of all tool-less manifolds.

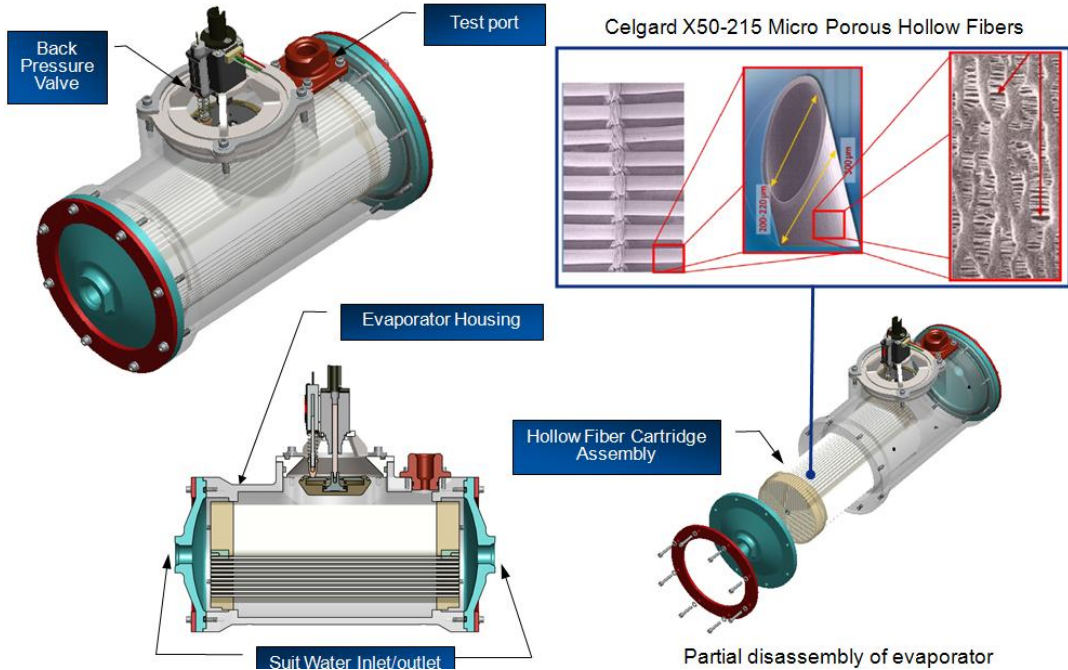

C. Preliminary Testing for Reduced Volume Prototype Design

1. Puck Gap Sizing Investigations

The most significant design change in RVP SWME is the elimination of the hollow fiber cartridge cage. In an effort to make a significant reduction in volume, the RVP SWME hollow fiber cartridge is potted directly into the acrylic housing. This design improvement significantly reduces SWME housing diameter. Developing this new technique involved significant investigation.

After the cage-less RVP SWME hollow fiber cartridge is created, it is sealed directly to the acrylic housing using polyurethane. This design element introduced significant risk; sizing this gap and determining the polyurethane formulation to seal the gap was critical to test article success. If the gap between the RVP SWME Cartridge puck is too small, the polyurethane may not penetrate sufficiently to create a viable bond to the acrylic housing. If the gap between the RVP SWME Cartridge puck is too large, the polyurethane may drip through the gap and onto the hollow fibers-- thereby impacting heat rejection performance and providing an insufficient bond. In order to test the behavior of the polyurethane that would be sealing the cartridge polyurethane puck to the acrylic housing, a test fixture consisting of controlled thickness gaps between cured polyurethane and acrylic was created. The gaps between the cured polyurethane (PU) and acrylic were created by inserting shim stock, ranging from .002 inches to .015 inches, into an acrylic housing, and pouring polyurethane in between the shim stock. The shim stock was then removed, leaving a gap that would closely simulate the gap size in actual RVP SWME design.

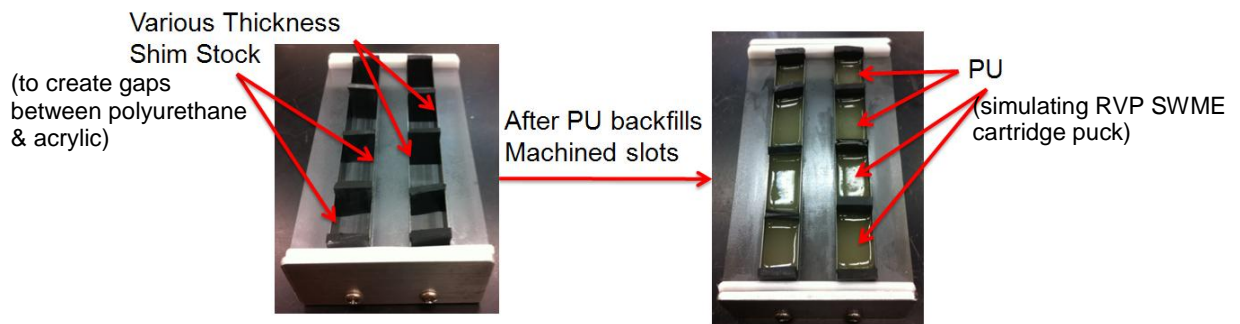

Cross Sectional View Before & After Shim Stock Removal

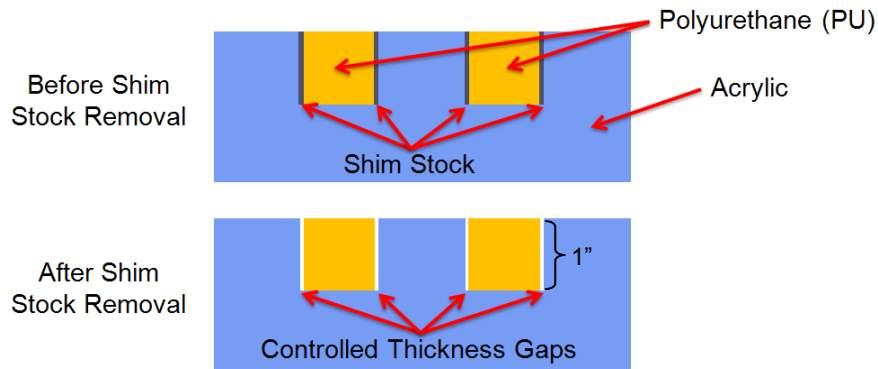

Various thicknesses of liquid polyurethane, achieved by allowing the polyurethane to polymerize for 5, 15, 30, and 45 minutes, were poured across these gaps to assess each formulations ability to seal the gap without dripping through the gap.

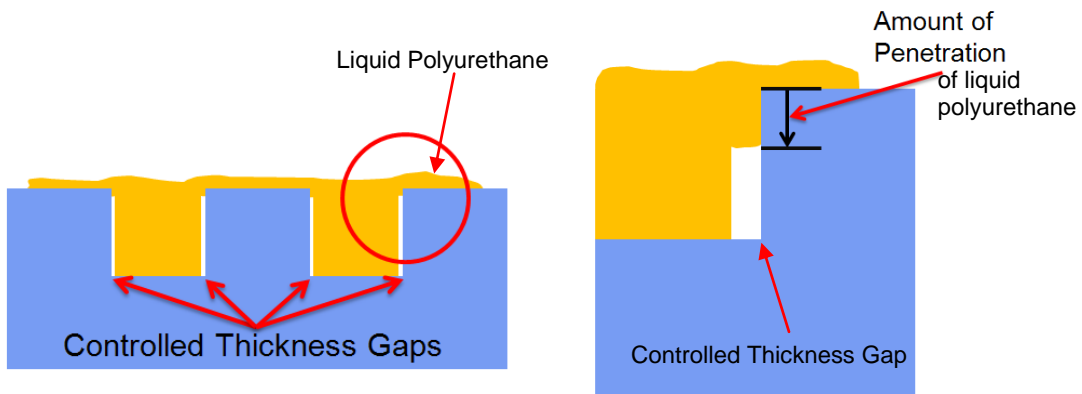

Test results from this investigation indicated that the gap between the RVP SWME cartridge polyurethane puck and the acrylic housing should be maintained between 0-.010", and the polyurethane should be allowed to polymerize for 30-45 minutes after preparation. This combination ensured that the polyurethane would not drip more than 1/8"—the gap depth of the RVP design.

Time Delay	Gap = .003"	Gap = .005"	Gap = .010"	Gap = .015"
5 min	NA	++	++++	++++
15 min	NA	-	++	++++
30 min	NA	-	+/-	++
45 min	NA	-	-	-

Penetration Key	
++++	Full Thickness
+++	3/4
++	1/2
+	1/4
+/-	1/8
-	Not Appreciable

After determining the ideal gap size and polyurethane formulation, the team performed a test to assess the maximum sustainable pressure between the RVP SWME Cartridge polyurethane puck and the acrylic housing. The maximum expected operating pressure of the RVP SWME was assessed to be 20 pounds per square inch differential (psid). An acrylic test fixture, designed to emulate the RVP SWME housing, was created. In addition, a polyurethane puck was created to emulate the RVP SWME cartridge puck. The polyurethane puck was then bonded to the acrylic housing simulator with liquid polyurethane. The housing simulator was then attached to a “plug pressure test rig,” which allowed the introduction and measurement of pressurized gaseous nitrogen to the polyurethane/acrylic bond. The first test article was pressurized in 5 psid increments up to 30 psid. The bond failed at 30 psid after 5 minutes. The location of the failure was between the polyurethane-polyurethane bond. It was speculated that the mold release used to create the puck may have impacted the ability of the liquid polyurethane to adhere. A new polyurethane puck was cast, without the use of mold release. Additionally, the acrylic housing and the polyurethane puck were both treated with Corona discharging and GSP-268 primer. The pressurization test was repeated three times with the new fabrication technique. Each test article was subjected to repressurization and depressurization schemes up to 100 psid, with no failures occurring. Additionally, one test article maintained 100 psid for 16 hours.



Plug Pressure Test Article

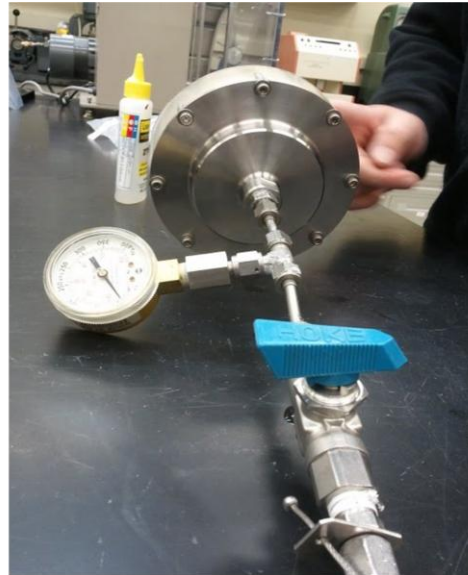

Plug Pressure Test Rig



*Acrylic-Polyurethane Bond Pressure Test
At 100 psid*

After successfully demonstrating the ability to seal the RVP SWME cage-less Cartridge polyurethane puck to the acrylic housing, design work and development of the new RVP SWME cage-less cartridge could begin.

D. Cage-less Cartridge Design and Development

In previous generation SWMEs, hollow fibers were inserted into a Delrin or stainless steel cage. After all of the 30 fiber bundles were inserted into the cage, they were bonded to the cage and held in place by pouring polyurethane into the base and curing in an oven. After curing, the polyurethane pucks were cut by hand to expose the open ends of the hollow fibers. The cage allowed the SWME Cartridge to be inserted and removed at will, and sealed with o-rings.

To reduce volume of the RVP SWME, the team designed a cage-less cartridge. This cartridge uses removable fabrication aides, which provide structure to the hollow fibers while the cartridge is being manufactured. One circular RVP SWME cartridge polyurethane puck mold has three rods extending vertically. On these three rods, two sets of combs provide guidance for the chevron shape. Each of 30 fiber bundles is placed into its corresponding comb slot, and polyurethane is poured into the mold, securing the hollow fiber chevrons in place. A second circular RVP SWME cartridge polyurethane puck mold is placed on the other end of the cartridge, and the process is repeated. The RVP SWME cartridge is allowed to polymerize until solid, and then can be lathe cut to expose the open hollow fiber ends. This new lathe-cutting technique is made possible by the new removable fabrication aides, which allow the entire cartridge to be chucked in a lathe and cut at a very slow rotational rate to avoid the formation of polyurethane dust and potential obstruction of the hollow fibers. The lathe-cutting technique is repeatable and safer than prior generation cutting techniques.

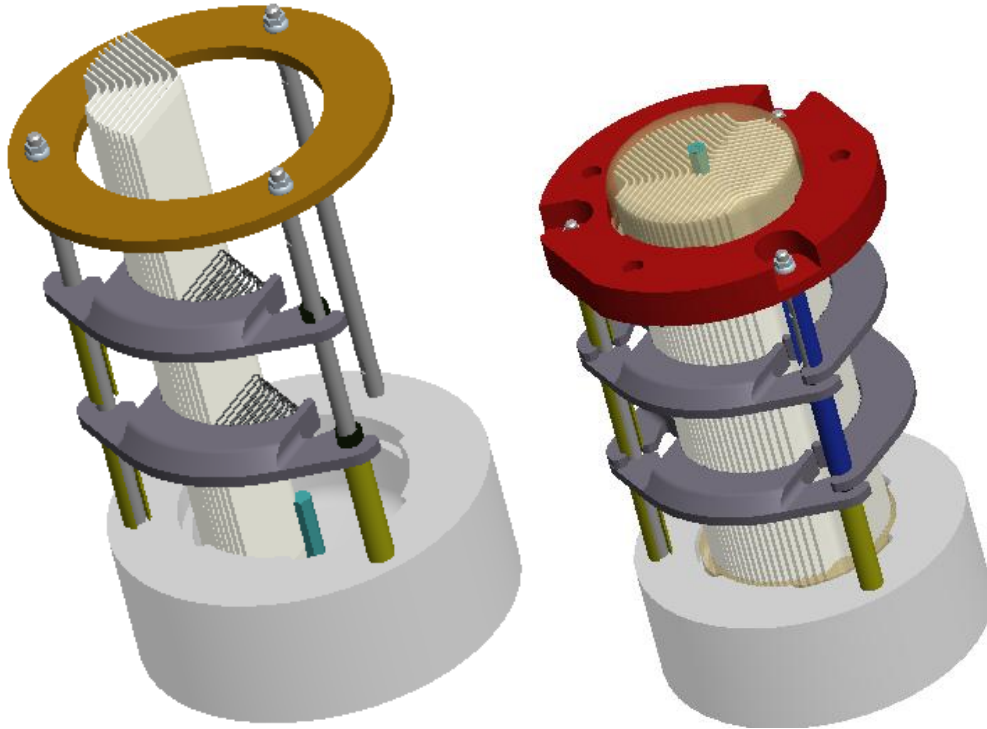

Left: RVP SWME cartridge with mold and removable fabrication aides: combs and fibers in installation process.

Right: RVP SWME cartridge with mold and removable fabrication aides with all fibers installed with

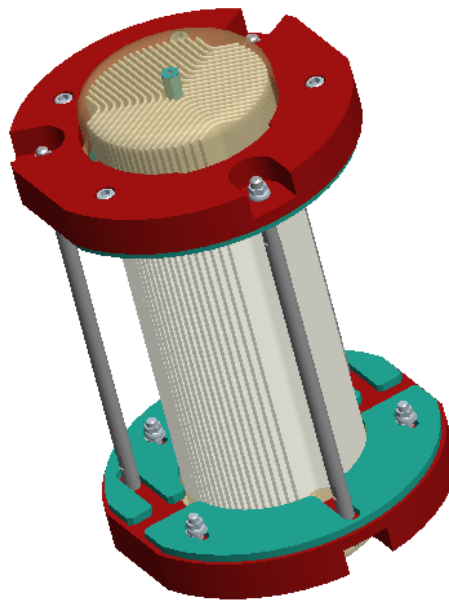

RVP SWME Cartridge with removable installation aides installed for lathe cutting.

E. Volumetric Results of Reduced Volume Prototype Spacesuit Water Membrane Evaporator design.

The new fabrication and packaging techniques for RVP SWME provided a 36% reduction in volume compared to Gen2 SWME.

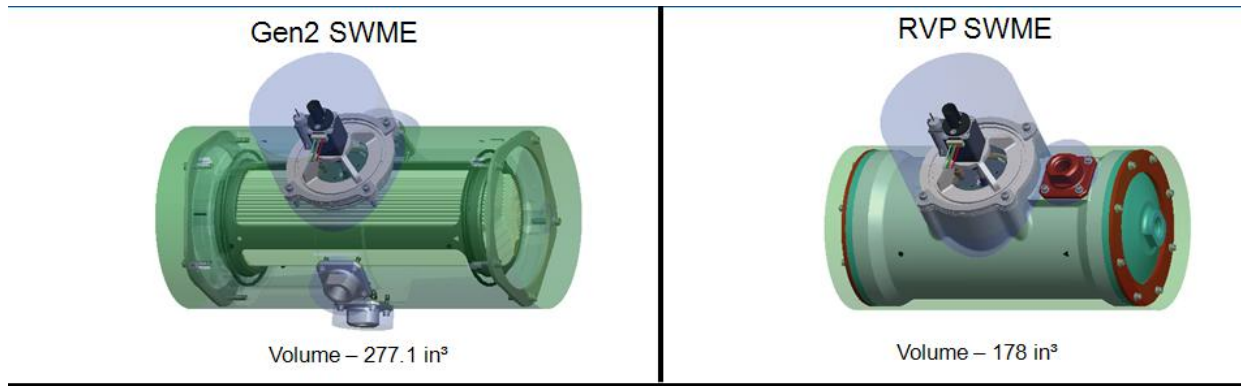

Volumes (in³)	
Gen2 SWME	277.1
RVP	178
RVP Requirement	277
RVP Goal (20% reduction)	222
Below Requirement By	99 (36%)
Below Goal By	43 (20%)

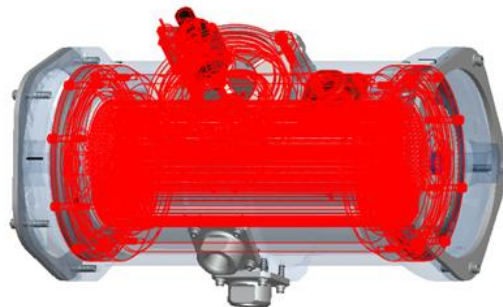

RVP SWME in red

F. Reduced Volume Prototype Spacesuit Water Membrane Evaporator (RVP SWME) Control

Results Pending

III. Reduced Volume Prototype Spacesuit Water Membrane Evaporator Preliminary Performance

After successful manufacturing of the RVP SWME, the test article was leak checked and run at vacuum to characterize heat rejection performance. *Results Pending.*

IV. Reduced Volume Prototype Spacesuit Water Membrane Evaporator Future Work

A. Advanced Extravehicular Mobility Unit Portable Life Support Subsystem (AEMU PLSS) 2.0 Testing

The RVP SWME is currently integrated into the packaged AEMU PLSS 2.0 test article. During the AEMU PLSS 2.0 testing, the SWME will undergo rigorous testing that will simulate actual EVA use, as well as contingency situations. Interaction and behavior of SWME with other AEMU PLSS components will be assessed.

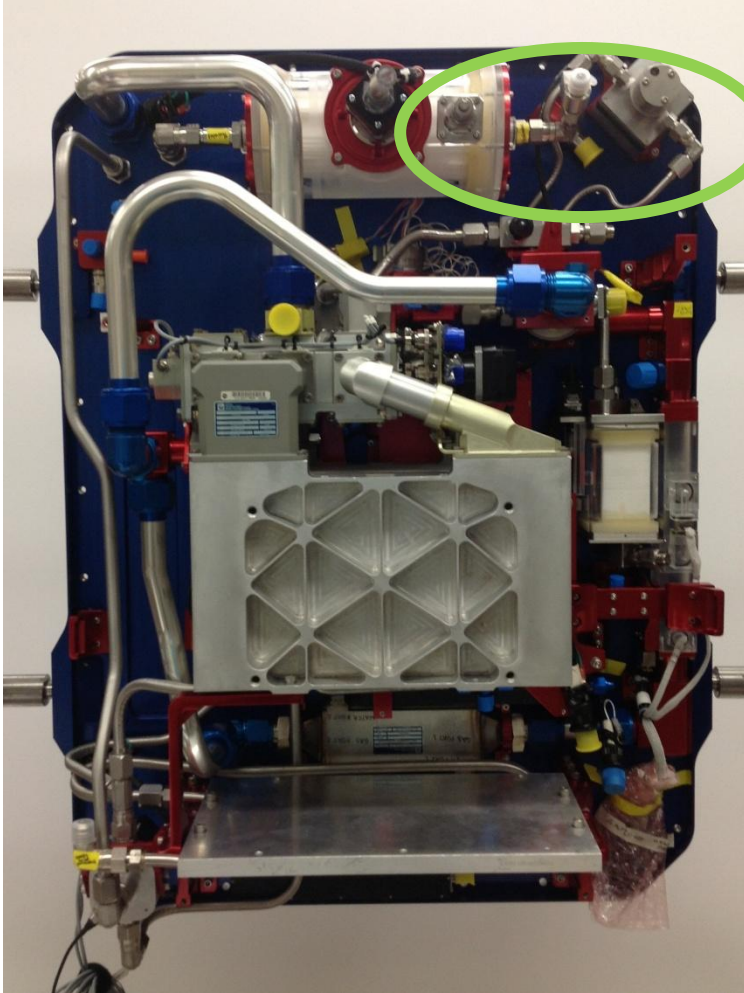

RVP SWME (circled in green) mounted on AEMU PLSS 2.0 Backplate.

B. Next-generation Reduced Volume Prototype Spacesuit Water Membrane Evaporator

During the AEMU PLSS 2.0 packaging exercise, the RVP SWME team noted volumetric inefficiencies of the RVP SWME. Due to the circular shape of the RVP SWME, a significant volume of free space around the test article cannot be utilized for other PLSS components. To maximize packaging efficiency, the team is investigating the fabrication of a Rectangular RVP SWME for AEMU PLSS 2.5 testing starting in 2014. The Rectangular RVP SWME (RRVP SWME) would provide the same amount of heat rejection as the RVP SWME. The major design changes of the Rectangular RVP SWME will be: 1) Rectangular shape: to improve overall AEMU packaging efficiency; 2) New fiber bundle orientation: the chevron pattern used in prior SWMEs will not be conducive to a rectangular shape. Instead, the team will most likely utilize equal sized fiber bundles layered in a parallel fashion; 3) Integration of a gate backpressure valve: using a gate valve that opens via sliding across a backpressure orifice on the RVP SWME housing will greatly reduce the volume occupied by the RVP SWME in the AEMU PLSS package. Currently, the poppet valve extends 4 inches from the RVP SWME housing. Design work for the Rectangular RVP SWME began in February 2013. Manufacturing is scheduled to begin in October 2013.

References

Pending