

NASA/CR-2013-217968



Characterization of the Reverberation Chamber at the NASA Langley Structural Acoustics Loads and Transmission (SALT) Facility

Ferdinand W. Grosveld

Northrop Grumman, Langley Research Center, Hampton, Virginia

February 2013

NASA STI Program . . . in Profile

Since its founding, NASA has been dedicated to the advancement of aeronautics and space science. The NASA scientific and technical information (STI) program plays a key part in helping NASA maintain this important role.

The NASA STI program operates under the auspices of the Agency Chief Information Officer. It collects, organizes, provides for archiving, and disseminates NASA's STI. The NASA STI program provides access to the NASA Aeronautics and Space Database and its public interface, the NASA Technical Report Server, thus providing one of the largest collections of aeronautical and space science STI in the world. Results are published in both non-NASA channels and by NASA in the NASA STI Report Series, which includes the following report types:

- **TECHNICAL PUBLICATION.** Reports of completed research or a major significant phase of research that present the results of NASA Programs and include extensive data or theoretical analysis. Includes compilations of significant scientific and technical data and information deemed to be of continuing reference value. NASA counterpart of peer-reviewed formal professional papers, but having less stringent limitations on manuscript length and extent of graphic presentations.
- **TECHNICAL MEMORANDUM.** Scientific and technical findings that are preliminary or of specialized interest, e.g., quick release reports, working papers, and bibliographies that contain minimal annotation. Does not contain extensive analysis.
- **CONTRACTOR REPORT.** Scientific and technical findings by NASA-sponsored contractors and grantees.

- **CONFERENCE PUBLICATION.** Collected papers from scientific and technical conferences, symposia, seminars, or other meetings sponsored or co-sponsored by NASA.
- **SPECIAL PUBLICATION.** Scientific, technical, or historical information from NASA programs, projects, and missions, often concerned with subjects having substantial public interest.
- **TECHNICAL TRANSLATION.** English-language translations of foreign scientific and technical material pertinent to NASA's mission.

Specialized services also include organizing and publishing research results, distributing specialized research announcements and feeds, providing information desk and personal search support, and enabling data exchange services.

For more information about the NASA STI program, see the following:

- Access the NASA STI program home page at <http://www.sti.nasa.gov>
- E-mail your question to help@sti.nasa.gov
- Fax your question to the NASA STI Information Desk at 443-757-5803
- Phone the NASA STI Information Desk at 443-757-5802
- Write to:
STI Information Desk
NASA Center for AeroSpace Information
7115 Standard Drive
Hanover, MD 21076-1320

NASA/CR–2013-217968

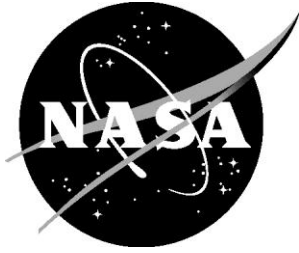

Characterization of the Reverberation Chamber at the NASA Langley Structural Acoustics Loads and Transmission (SALT) Facility

Ferdinand W. Grosveld

Northrop Grumman, Langley Research Center, Hampton, Virginia

National Aeronautics and
Space Administration

Langley Research Center
Hampton, Virginia 23681-2199

Prepared for Langley Research Center
under Contract NNL12AA09C

February 2013

The use of trademarks or names of manufacturers in this report is for accurate reporting and does not constitute an official endorsement, either expressed or implied, of such products or manufacturers by the National Aeronautics and Space Administration.

Available from:

NASA Center for AeroSpace Information
7115 Standard Drive
Hanover, MD 21076-1320
443-757-5802

TABLE OF CONTENTS

INTRODUCTION	5
TEST ARRANGEMENT	5
Reverberation Chamber	5
Acoustic Horn Airstream Modulators	5
Measurement Locations.....	6
MEASUREMENTS, REQUIREMENTS AND ANALYSIS.....	7
Reverberation Time Measurements.....	7
Room Diffusivity.....	9
Room Absorption	12
Sound Field Diffusers.....	13
Diffusivity Summary	14
CONCLUSIONS.....	14
ACKNOWLEDGEMENTS.....	15
REFERENCES	15
TABLES	17
FIGURES.....	27
APPENDIX.....	33

LIST OF TABLES

Table 1. Nominal reverberation chamber geometric properties.....	17
Table 2. Ambient test conditions in the reverberation chamber.	17
Table 3. Reverberation time measurements chamber configurations.	17
Table 4. Mutual distances between the three microphones and their distances from the loudspeaker sources.	17
Table 5. Dynamic range between the maximum impulse noise level and the background noise levels in the reverberation chamber.....	18
Table 6. Instrumentation and equipment for the reverberation measurements.	18
Table 7. EDT reverberation times for four measurements (Configuration A) at microphone M3 and source location L1, their mean and their standard deviation (SD).....	19
Table 8. T_{20} reverberation times for four measurements (Configuration A) at microphone M3 and source location L1, their mean and their standard deviation (SD).	19
Table 9. Minimum distances to avoid the effects from direct radiated sound, based on the Configuration A mean EDT and the T_{20} reverberation times. ²	20
Table 10. Calculated acoustic modes assuming a rectangular reverberation chamber without splayed walls.	20

Table 11. Calculated modal density assuming a rectangular reverberation chamber without splayed walls.....	24
Table 12. The uniform distribution minimum frequencies and Schröder diffuse field cut-off frequencies as function of the Configuration A mean reverberation times.....	24
Table 13. Instrumentation and equipment for the sound pressure level measurements.....	25
Table 14. Computed standard deviations for eight repeated measurements by ten microphones (SD_1 - SD_{10}) with the source at location L3, the total SD at locations L3 and L4, and the maximum allowed in ISO 3741. ³	25
Table 15. Calculated power attenuation coefficient ¹⁶ α_c and the atmospheric absorption correction term $4mV$	26
Table 16. Equivalent sound absorption area and averaged Sabine absorption coefficient for Configuration A.	26
Table 17. Summary of several criteria in the International Standards and literature that define the range of one-third octave bands for which measurements in the reverberation chamber are valid.....	27

LIST OF FIGURES

Figure 1. The large 35 Hz cut-off frequency exponential horn.....	27
Figure 2. The large 35 Hz cut-off frequency horn and the small 160 Hz cut-off frequency horn (foreground) in the reverberation chamber. The 38 mm thick MDF panel with the NASA logo is offset from the TL window to leave breaches along its four sides allowing air flow to escape to the adjacent anechoic chamber (Configuration C). For reverberation measurements in the empty chamber without the two horns, the offset panel is replaced by a 57 mm thick MDF panel mounted flush in the transmission loss window (Configuration A).....	28
Figure 3. Sketch of the reverberation chamber layout showing the three loudspeaker (L1-L3) and the four microphone locations (M1-M4).	28
Figure 4. Brüel & Kjær Type 2231 Modular Precision Sound Level Meter with the Type 1625 One-Third Octave Filter Set and the Type BZ7108 Reverberation Processor.....	29
Figure 5. Twelve measured EDT reverberation times and their mean (solid line) with the MDF insert mounted flush in the TL window but without the two horns in the chamber (Configuration A).	29
Figure 6. Twelve measured T_{20} reverberation times and their mean (solid line) with the MDF insert mounted flush in the TL window but without the two horns in the chamber (Configuration A).	29
Figure 7. Mean measured EDT and T_{20} reverberation times with the MDF insert mounted flush in the TL window but without the two horns (Configuration A).....	30
Figure 8. Mean measured EDT and T_{20} reverberation times with the MDF offset in front of the TL window (exposing gaps) including the 160 Hz horn, but without the 35 Hz horn (Configuration B).....	30
Figure 9. Mean measured EDT and T_{20} reverberation times with the MDF offset in front of the TL window (exposing gaps) and the two horns deployed (Configuration C).....	30
Figure 10. Mean measured EDT and T_{20} reverberation times with the offset and flush MDF panels mounted and the two horns deployed (Configuration D).....	30
Figure 11. Mean measured EDT reverberation times for Configurations A-D.	31
Figure 12. Mean measured T_{20} reverberation times for Configurations A-D.	31

Figure 13. Measured EDT reverberation time variations from the mean over four repeated measurements for Configuration A at microphone M3 and source location L1.....	31
Figure 14. Measured T_{20} reverberation time variations from the mean over four repeated measurements for Configuration A at microphone M3 and source location L1.....	31
Figure 15. Bolt ¹² room proportion criterion showing curve enclosing rectangular room dimension ratios yielding the smoothest frequency response at low frequencies.	32
Figure 16. Measured and ISO 354 estimated ² standard deviations of twelve T_{20} reverberation times for Configuration A.	32
Figure 17. Sketch of the reverberation chamber layout for the ten-microphone variability measurements showing the two loudspeaker (L4 and L5) and the ten microphone (M1-M10) locations.....	32
Figure 18. Total standard deviation (SD) of the sound pressure levels for ten microphones at two “white” noise sound source locations, and the maximum SD in the International Standard ISO 3741. ⁴	33

LIST OF APPENDIX TABLES

Table A1. EDT and T_{20} integrated impulse response reverberation times for source location L1 (Configuration A).....	33
Table A2. EDT and T_{20} integrated impulse response reverberation times for source location L2 (Configuration A).....	34
Table A3. EDT and T_{20} integrated impulse response reverberation times for source location L3 (Configuration A).....	34
Table A4. Four-microphone mean EDT and T_{20} for the three source locations L1, L2 and L3 (Configuration A).....	35
Table A5. Standard deviation (SD) of EDT and T_{20} for the three source locations L1, L2 and L3 (Configuration A).....	35
Table A6. EDT and T_{20} integrated impulse response reverberation times for source location L1 (Configuration B).....	36
Table A7. EDT and T_{20} integrated impulse response reverberation times for source location L2 (Configuration B).....	36
Table A8. EDT and T_{20} integrated impulse response reverberation times for source location L3 (Configuration B).....	37
Table A9. Mean EDT and T_{20} reverberation times for twelve measurements (Configuration B) and their standard deviation (SD).	37
Table A10. EDT and T_{20} integrated impulse response reverberation times for source location L1 (Configuration C).....	38
Table A11. EDT and T_{20} integrated impulse response reverberation times for source location L2 (Configuration C).....	38
Table A12. EDT and T_{20} integrated impulse response reverberation times for source location L3 (Configuration C).....	39
Table A13. Mean EDT and T_{20} reverberation times for twelve measurements (Configuration C) and their standard deviation (SD).	39

Table A14. EDT and T_{20} integrated impulse response reverberation times for source location L1 (Configuration D).....	40
Table A15. EDT and T_{20} integrated impulse response reverberation times for source location L2 (Configuration D).....	40
Table A16. EDT and T_{20} integrated impulse response reverberation times for source location L3 (Configuration D).....	41
Table A17. Mean EDT and T_{20} reverberation times for twelve measurements (Configuration D) and their standard deviation (SD).	41
Table A18. Equivalent sound absorption area and averaged Sabine absorption coefficient for Configuration B.	42
Table A19. Equivalent sound absorption area and averaged Sabine absorption coefficient for Configuration C.	42
Table A20. Equivalent sound absorption area and averaged Sabine absorption coefficient for Configuration D.	43

INTRODUCTION

The Structural Acoustic Loads and Transmission (SALT) facility at NASA Langley Research Center consists of an anechoic chamber, a reverberation chamber and a transmission loss (TL) window connecting the two chambers. The reverberation chamber has multiple uses, including sound power level measurements of small sound sources, experimental determination of the random incidence absorption coefficients of materials, as the source room for transmission loss testing, and for high-intensity noise testing to establish the vibration response and fatigue tolerance of aerospace structures. In 2011 the noise generating capabilities in the reverberation chamber were enhanced with two fiberglass reinforced polyester resin exponential horns, each coupled to Wyle Acoustic Source WAS-3000 airstream modulators. A large horn, with a 35 Hz cut-off frequency, will be used for acoustic tests requiring a very high intensity noise source at low frequencies. A simplified engineering drawing of the 35 Hz horn is shown in Figure 1. A small horn, with a cut-off frequency of 160 Hz, is intended to enhance the low frequencies of the regular SALT sound generating system. Both horn assemblies are mounted on moveable carriage systems. Figure 2 depicts the 35 Hz and 160 Hz horns deployed in the SALT reverberation chamber. This document describes the characterization of the reverberation chamber in terms of the background noise, diffusivity, sound pressure levels, the reverberation times and the related overall acoustic absorption in the empty chamber and with the acoustic horn(s) installed. The frequency range of interest includes the one-third octave bands with center frequencies from 80 Hz to 8000 Hz.

TEST ARRANGEMENT

Reverberation Chamber

The 279 m³ reverberation chamber measures approximately 6.4 m by 9.7 m by 4.5 m (Table 1) and is structurally isolated from the rest of the building by a 0.26 m air gap from the surrounding 0.46 m thick concrete building walls. The chamber walls and ceiling are splayed to diminish the effects of standing waves between opposite surfaces and enhance the diffusivity of the chamber at lower frequencies. The total surface area of the walls, floor and ceiling is approximately 269 m². Fifteen permanent, high-frequency compression drivers are installed along the two walls adjacent to the wall containing the TL window, while three compression drivers are mounted on the wall opposite the TL window. These permanent acoustic sources are complemented by removable sources: four ceiling-mounted and two floor-standing two-way speaker boxes for the mid and low frequencies. For the reverberation time measurements in this investigation only one floor standing speaker box was used to excite the chamber. The ceiling mounted speaker boxes and the other floor standing box were removed from the chamber to avoid including their sound absorption properties in the measurements. Ambient conditions were measured and were virtually constant throughout the testing period. The ambient test conditions are listed in Table 2.

Acoustic Horn Airstream Modulators

The WAS-3000 is an electro-pneumatic airstream modulator rated at 30 kW output with either a sine wave or random noise input over a frequency range of 25 Hz to 10 kHz. The electric input to the modulator is 20 volts with a maximum amperage of 5 amperes. The air pressure input may vary from 15 to 35 pound-force per square inch gauge (gpsi). The large horn has a low frequency cut-off at 35 Hz and exponentially expands from a 0.102 m diameter throat area to a 1.524 m diameter exit area (Figure 1). The centerline of the “folded” design has an approximate length of 4.5 m. The smaller sound source incorporates a straight 0.61 m long horn expanding from a 0.102 m diameter throat to a 0.341 m diameter exit, with a 160 Hz low frequency cut-off. The modulators are connected to flexible air supply

lines. Both horns are installed on a frame structure supported by casters such that they can be moved into and out of the chamber.

Measurement Configurations

Four configurations of the reverberation chamber, listed in Table 3, were characterized in this study. The first configuration, labeled Configuration A, corresponds to an empty chamber with a three-ply, 57 mm thick medium-density fiberboard (MDF) insert installed flush in the TL window to prevent loss of acoustic energy to the anechoic chamber. In the second test configuration (Configuration B) the small 160 Hz horn was moved into the chamber and the flush MDF insert in the TL window was replaced by a square 1.40 m MDF panel, 38 mm thick, offset 76 mm in front of the open transmission loss window. This offset configuration, with an air gap on all four sides, provides an outlet into the anechoic chamber for the pressurized air used to drive the WAS-3000 modulators. After Configuration B measurements were completed the large 35 Hz horn was also moved into the chamber (Configuration C in Figure 2). In the fourth and final configuration (Configuration D) the flush panel was re-installed behind the offset panel, thereby closing off the ventilation path through the transmission loss window opening. Although Configuration D is not practical for high intensity acoustic testing, it provided a means to characterize the impact of the air gaps and the two horns on the acoustical properties of the reverberation room.

Measurement Locations

The procedures and requirements for the experimental determination of the random absorption coefficients of materials in the reverberation chamber are available in the International Organization for Standardization (ISO) publication ISO 354.¹ The absorption coefficients are determined by measuring reverberation times without and with the test article in the chamber. ISO 354 stipulates that the number of spatially independent measured decay curves shall be at least a total of twelve, with a minimum number of three microphone locations and two source locations. The same standard requires that the different microphone positions be at least 1.5 m apart, 2 m from the sound source and 1 m from any room surface. Four different microphone locations and three different sound source locations were selected that were in compliance with these ISO 354 requirements. The microphone (M1-M4) and sound source locations (L1-L3) are shown in Figure 3. The speaker box was positioned in one of three corners of the chamber facing towards the center. At the corner locations the sound source excites the maximum number of room modes. The center of the sound source was assumed 0.5 m off the floor. The measurement microphone was mounted on a tripod 1.67 m above the floor. The distances between each microphone and each source location are listed in Table 4 showing compliance with the ISO 354 requirement of being at least 2 m apart. The distances between the three microphone locations in Table 4 also show that they are separated by more than 1.5 m as specified in ISO 354. International Standard ISO 3382² applies to the measurement of reverberation time in rooms with reference to other acoustical parameters. The ISO 3382 standard requires the measurement locations to be at least one-quarter wavelength from the nearest reflecting surface. The wavelength for the lowest frequency in each one-third octave band between 80 Hz and 8000 Hz is listed in Table 5. One quarter of the longest wavelength in Table 5 equates to 1.21 m, which is shorter than the closest distance of 1.83 m between a microphone and one of the chamber walls (Figure 3). The distances between microphones in Table 4 satisfy the ISO 3382 requirement of being at least half a wavelength apart for all frequencies in the 100 Hz and higher one-third octave bands. To avoid the effects from the direct radiated sound, the distance between the sound source and any microphone position should exceed a minimum distance d_{min} , which can be approximated by the equation²

$$d_{min} = 2 * \sqrt{\frac{V}{cT}} \quad (1)$$

where V is the volume [m^3] of the chamber, c is the speed of sound [m/s], and T is the reverberation time [s]. The shortest distance between a speaker box and a microphone location is 2.56 m, between L2 and M2 (Table 4), sufficient for a minimum reverberation time of 0.5 seconds. The same minimum distance d_{min} is required in the International Standard ISO 3741, describing the determination of sound power levels and sound energy levels of noise sources using sound pressure in a reverberation chamber.³

MEASUREMENTS, REQUIREMENTS AND ANALYSIS

Reverberation Time Measurements

Instrumentation and Equipment - Reverberation time measurements were performed with a Brüel & Kjær (B&K) Type 2231 Modular Precision Sound Level Meter connected to a Type 1625 One-Third Octave Filter Set, while being controlled by a Type BZ7108 Reverberation Processor (Figure 4).⁴ The reverberation processor is set up to calculate reverberation and early decay times using the integrated impulse response method proposed by Schröder.⁵ The specifications of the reverberation time instrumentation and equipment are summarized in Table 6 including the manufacturer, the model/type, the serial number, the NASA ECN/Calibration number, the calibration date and relevant notes.

Integrated Impulse Response Method - The maximum impulse noise level generated through the loudspeaker box at location L1 (Figure 3) was measured by the sound level meter microphone at location M1. The maximum impulse noise level, the background noise level and the resulting dynamic range are tabulated in Table 5 for the 80 Hz to 8000 Hz one-third octave bands. The table shows that the dynamic range available for the reverberation time measurements exceeds the 35 dB dynamic range requirement in ISO 3382² over the entire frequency range of interest. The B&K 2231 with the reverberation processor (Figure 4) was used to compute the reverberation times from the response of the chamber to gated band-limited noise bursts. The integrated impulse response method obtains the decay curves by reverse-time integration of squared impulse responses. At the start of the tests the sound level meter monitors the background noise. After a preset time has elapsed, the meter generates a band-limited burst signal in the lowest one-third octave frequency band of interest, corresponding to 80 Hz for this study. The burst signal is amplified by a 375 Watt (RMS) Carver Power Amplifier to drive a two-way 250 Watt (continuous) JBL loudspeaker box. The sound level meter then samples the sound decay in the chamber and the reverberation module calculates the reverberation times. Subsequently, a noise burst in the next one-third octave band is transmitted and sampled, and the reverberation times are again calculated. This procedure was repeated to include all 80 Hz to 8000 Hz one-third octave bands. The process was software-controlled to obtain automated, reproducible and accurate results. The calculated reverberation times included the Early Decay Time (EDT) and the T_{20} reverberation time. The EDT is defined as the estimated time required for 60 dB decay in sound pressure level (SPL), based on the early SPL decay between 0 dB and -10 dB. The T_{20} parameters indicate the estimated times required for a 60 dB decrease in SPL based on the SPL decays between -5 dB and -25 dB. Since the EDT is the reverberation time derived from the initial 10 dB decay of the signal, it includes the early reflections which arrive initially from the shortest paths to the source before rapidly increasing in number and direction. In a perfectly diffuse acoustic field, EDT would yield the same values as the T_{20} reverberation time. However, at the lower frequencies the sound field is determined by acoustic modal response and the EDT is more dependent on the geometry of the chamber and on the measurement location.⁶ The low modal participation at the lower frequencies results in a faster rate of decay and shorter reverberation times than for T_{20} which is not evaluated until the signal is 5 dB down and does not include these early reflections. The T_{20} measurements better describe the physical absorption properties of the chamber, while the EDT is useful in the analysis of the subjective response to the early reflections.

EDT and T_{20} reverberation times at four microphones M1-M4, with the room in Configuration A, are listed in Table A1, Table A2 and Table A3 of the Appendix for loudspeaker sources L1, L2 and L3, respectively. The mean reverberation time over the twelve source-microphone combinations is computed from the individual reverberation time decay rates as

$$\bar{T} = \frac{N}{\frac{1}{T_1} + \frac{1}{T_2} + \dots + \frac{1}{T_N}} \quad (2)$$

where the number of measurements, N , equals 12. The standard deviation SD of the reverberation times is defined by^{7,8}

$$SD = \sqrt{\frac{(T_1 - \bar{T})^2 + (T_2 - \bar{T})^2 + \dots + (T_N - \bar{T})^2}{N - 1}} \quad (3)$$

The twelve measured EDT and T_{20} reverberation times and their mean are shown in Figure 5 and Figure 6, respectively. The dips in the mean curves at low frequencies are believed to be the result of the low acoustic modal density and damping in the chamber. The mean of the EDT and T_{20} reverberation times measured at four microphone locations with the sound source either at location L1, L2 or L3 are listed in Table A4 of the Appendix. The mean of all twelve measurements (L1-L3) is also tabulated in Table A4. The standard deviations (SD) of measurements at four microphone locations with the source located either at L1, L2 or L3, and the total SD of all twelve measurements are summarized in Table A5 of the Appendix. The mean EDT and mean T_{20} over twelve measurements are compared in Figure 7, showing generally longer reverberation times (up to 16% at the lowest frequency of interest) for the T_{20} procedure and calculation.

The measured EDT and the T_{20} reverberation times for Configurations B, C, and D and the mean and standard deviation (SD) of twelve measurements are listed in Table A6-Table A9, Table A10-Table A13, and Table A14-Table A17 of the Appendix, respectively. The mean EDT and T_{20} reverberation times for Configurations B through D are compared in Figure 8 through Figure 10. For all configurations the T_{20} reverberation times are again generally longer than the reverberation times obtained with the EDT method, by up to 9.2% at some frequencies. The dips in the Configuration B-D reverberation time curves at the lower frequencies have mostly vanished as the modal damping in the chamber has increased due to the flush mounted panel in the TL window and the presence of the horns. The surfaces of the horns also scatter and diffuse the sound field thereby increasing the chamber modal density in the lower frequency bands. ISO 3741³ requires that the reverberation chamber surfaces have absorptive properties such that the reverberation time in each one-third-octave band below 6300 Hz is numerically greater than the ratio of the volume V and total surface area S . All measured reverberation times in this study were greater than 1.04 seconds thereby conforming to the requirements of the ISO 3741 standard.

The mean measured EDT reverberation times for all four chamber configurations (A-D) are compared in Figure 11 while the T_{20} results for the four chamber configurations are shown in Figure 12. The longest reverberation times were measured in the empty chamber with the MDF insert mounted flush in the TL window (Configuration A). Moving the 160 Hz horn into the chamber and replacing the flush TL window insert by the offset MDF panel resulted in reduced reverberation times as evidenced in Figure 11 and Figure 12. Moving the large 35 Hz horn into the reverberation chamber in addition to the 160 Hz horn (Configuration C) provides extra absorption to the chamber due to the surface area of the 35 Hz horn. The presence of the horn scatters and diffuses the sound and also prevents some of the acoustic energy to reach the measuring microphone as energy is lost when acoustic waves bounce around

between the exterior surfaces of the horn and the chamber walls, floor and ceiling. Installing the flush mounted MDF panel insert in the TL window in addition to the offset MDF panel (Configuration D) prevented some of the acoustic energy from escaping the chamber, thereby slightly increasing the reverberation times between 315 Hz and 1600 Hz, but otherwise not significantly differing from the results obtained for Configuration C (Figure 11 and Figure 12).

Repeatability - The repeatability of the measurements for a particular microphone and source location is illustrated by the mean and the standard deviations (SD) results in Table 7 for four repeated EDT reverberation measurements by microphone M3, with the source located at L1 and chamber Configuration A. The SD is less than or equal to 0.07 for all frequencies above the 160 Hz one-third octave band. Figure 13 shows that the variation from the mean is less than 0.1 second at all frequencies except for one data point in the 160 Hz one-third octave band. The mean and SD results for four repeated T_{20} measurements by the same microphone and for the same source location are listed in Table 8. The SD is less than or equal to 0.06 for all frequencies higher than the 160 Hz one-third octave band. The same data are plotted as the variation from the mean in Figure 14 showing that all measurement data for the one-third octave frequency bands 200 Hz and higher are less than 0.1 second off the mean value, while for the lower frequency bands the measurements are within 0.25 seconds of the mean reverberation time.

Minimum Distance – Having measured the mean EDT and T_{20} reverberation times, the minimum distance between a microphone and a sound source location to avoid the effects from the direct radiated sound can now be calculated by applying Equation 1. The minimum distance d_{min} is longest for the highest frequency of interest (1.60 m at 8000 Hz) as shown in Table 9 for Configuration A, but is well below the shortest distance of 2.56 m between a source location and a microphone in Table 4.

Room Diffusivity

In the International Standards and the open literature several different requirements and descriptions are offered to define the diffusivity of the sound field in a reverberation chamber. The sound diffusivity is dependent on the frequency. Below the lowest acoustic resonance the chamber behaves like a compressible volume of air. Above this frequency a sound field of relatively isolated room modes dominates the response of the chamber. At higher frequencies the frequency spacing decreases and modes overlap until the modal density and the modal overlap is such that the sound field can be treated in a statistical sense. A diffuse sound field is defined as an acoustic environment in which the acoustic energy density is the same at all locations, which implies that the acoustic energy of sound waves flows in all directions with equal probability. A diffuse sound field is important because it is the basis for the equations used to establish the sound power level of small sound sources from measured sound pressure levels in the reverberation chamber, and to determine the random absorption coefficients of materials from measured reverberation times. A diffuse field is also required for the sound waves incident on the test article during transmission loss testing.

Acoustic Modal Response - The geometry of the chamber determines the acoustic modal response. To simplify calculations of the modal frequencies the reverberation chamber was modeled as a rectangular room with approximate dimensions 6.4 m by 9.7 m by 4.5 m as listed in Table 1. The normal mode frequencies f_n of the room are given by⁹

$$f_n = \frac{c}{2} \sqrt{\left(\frac{n_x}{l}\right)^2 + \left(\frac{n_y}{w}\right)^2 + \left(\frac{n_z}{h}\right)^2} \quad (4)$$

where l , w and h are the length [m], the width [m] and the height [m] of the room, and n_x , n_y and n_z are the respective mode numbers in those directions. Thirty-nine modal frequencies were computed in the reverberation chamber for the 80 Hz and lower one-third octave bands. The mode numbers, modal frequencies, and number of modes in band are summarized in Table 10. The modal density is defined by⁹

$$\frac{dM}{df} \approx \frac{4\pi f^2 V}{c^3} + \frac{\pi f S}{2c^2} + \frac{P}{8c} \quad (5)$$

where M is the number of modes in the room, f is the one-third octave band center frequency [Hz], V is the volume [m³], S is the total wall surface area [m²] and P is the total edge length [m]. The modal densities were calculated and the results are listed in Table 11.

Chamber Volume – The reverberation test chamber has a volume of 279 m³ which is larger than the minimum volume of 200 m³ recommended in the International Standard ISO 3741 for measurements down to the 100 Hz one-third octave band.³ Twenty room modes in a third octave band have been suggested as the least permissible number to achieve diffusion in a reverberation chamber.¹⁰ The volume V [m³] is then related to the longest wavelength λ [m] of interest by

$$V \geq 4\lambda^3 \quad (6)$$

A volume of at least 229 m³ is needed to have twenty room modes in the 100 Hz one-third octave band. Table 10 shows that twenty-four modes were computed assuming a rectangular reverberation chamber.

Morse¹¹ suggests a minimum frequency f_{min} [Hz] above which the peaks of the room modes merge together and the chamber is uniform in frequency and in distribution

$$f_{min} = \sqrt{\frac{c^3 T}{16\pi V}} \quad (7)$$

The calculated minimum frequencies f_{min} are listed in Table 12 based on the Configuration A mean reverberation times. The results suggest the sound field is uniform in the 200 Hz one-third octave band and higher.

Chamber Dimension Ratio's – ISO 354 requires that the shape of the reverberation chamber is such that the following condition is fulfilled¹

$$I_{max} < 1.9V^{1/3} \quad (8)$$

where I_{max} is the longest straight line (diagonal) which fits within the boundaries of the chamber [m]. I_{max} for the reverberation chamber was calculated to equal 12.46 m. Considering the splayed walls of the chamber it was concluded that the condition in Equation 8 was met, although narrowly. The ratios of the chamber dimensions relative to its height are 1:1.42:2.15 avoiding ratios of small whole numbers thereby achieving a more uniform distribution of the modes in the low frequency bands. Richard Bolt developed the room proportion criterion¹² for small rectangular rooms indicating room dimension ratios yielding the smoothest frequency response at low frequencies. The dimension ratios for the reverberation chamber fall within this criterion, as shown in Figure 15, but the validity of this criterion would be from approximately 20 Hz up to 80 Hz for the 279 m³ chamber. Walker¹³ investigated rooms up to a height of 4.9 m with a volume of 200 m³ and established the criterion

$$1.1 \frac{w}{h} \leq \frac{l}{h} \leq 4.5 \frac{w}{h} - 4 \quad (9)$$

subject to the width $w < 3h$ and the length $l < 3h$. A 5% protective rule also was applied which entailed that the width/height and length/ height ratios would not be within 5% of an integer number. This criterion is also plotted in Figure 15 with the dimension ratios of the reverberation chambers within the boundaries of the Walker criterion.

Schröder Frequency - In a diffuse sound field the average energy density is the same throughout the chamber and all directions of propagation are equally probable. The lowest frequency at which the modal density is sufficient to constitute a diffuse field, with a modal overlap index greater than three, is given by the Schröder cut-off frequency¹⁴

$$f_s = \sqrt{\frac{c^3 T}{4 \ln 10 * V}} \quad (10)$$

where c is the speed of sound [m/s], T is the reverberation time of the chamber [s] and V is the volume of the chamber [m³]. The Schröder frequencies for the T_{20} reverberation times are tabulated in Table 12. Below these frequencies the chamber acoustic pressure responses are dominated by individual room modes. Statistical consideration of the sound field in a room is only valid when the sound field is diffuse. The calculated Schröder cut-off frequencies in Table 12 indicate that the 400 Hz one-third octave band is the lowest frequency band for which the acoustic field can be treated in a statistical sense rather than by analysis of the individual acoustic modes in the chamber. However, Reference 15 discusses that it can be deduced from Schröder's theory that, from measurements, one cannot with certainty detect a lower limit for the high-frequency region that exceeds approximately $0.5 f_s$. This suggests a frequency transition region between the modal response and the statistical approach and the reverberation chamber volume can be treated as an (almost) diffuse field down to the 200 Hz one-third octave band (Table 12). For the 200 Hz one-third octave band the estimated modal density at the center frequency exceeds 4 (Table 11).

Standard Deviation Reverberation Time – The ISO 354 relative standard deviation SD_{pred} of the reverberation time T_{20} can be predicted by¹

$$SD_{pred} = \sqrt{\frac{(2.42 + 3.59 / N) T}{f}} \quad (11)$$

where N is the number of included decay curves. The estimated ISO 354 standard deviation is compared with the standard deviation over twelve T_{20} reverberation time measurements for Configuration A in Figure 16. Good agreement is obtained for the one-third octave bands having center frequencies of 250 Hz and higher. It is concluded that in the 200 Hz and lower one-third octave bands the sound field is not sufficiently diffuse.

Standard Deviation Sound Pressure Levels – ISO 3741³ requires all test rooms to be qualified for the measurement of broadband sound using a procedure of six or more reverberant sound field measurements of the one-third octave band time-averaged sound pressure levels in the chamber, each with the reference sound source placed at a different location within the chamber. The instrumentation and microphones array should be the same as used in the actual tests. The source locations shall be at least 1.5 m from a wall and any two source locations shall be one quarter wavelength apart. To

accommodate a more general measurement of the variability in the coupling of the sound source and the reverberant field, a random sound field was generated by a loudspeaker source and measured by ten microphones (M1-M10 in Figure 17) distributed in the chamber. Distances to the walls were commensurate with ISO 3741. The source location L4 (Figure 17) was selected at 1.5 m from the walls in the left corner near the chamber entrance. A second ten-microphone measurement was made with the loudspeaker sound source 1.5 m from the center of the left wall (L5 in Figure 17). Each of the two ten-microphone measurements were repeated eight times. The instrumentation and equipment used for the sound pressure level measurements are listed in Table 13. The standard deviation SD_{SPL} is related to the uniformity of the sound pressure field measured by the ten microphones and is calculated from³

$$SD_{SPL} = \sqrt{\sum_k^K \frac{(L_{pk} - L_{pm})^2}{K-1}} \quad (12)$$

where L_{pk} is the band time-averaged sound pressure level [dB], L_{pm} is the arithmetic mean of the band time-averaged sound pressure level [dB], and K is the number of measurements. Table 14 shows the standard deviations SD_1 - SD_{10} for the eight repeated measurements at each of the ten microphones for the loudspeaker source located at L4. The SD of the mean of the repeated measurements at the ten microphones for source location L4 is indicated by SD_{L4} in Table 14. Similarly, the SD of the mean of the repeated measurements at ten microphones for source location L5 is listed in Table 14 as SD_{L5} . The SD_{L4} and SD_{L5} results are compared to the SD_{max} values specified in ISO 3741³ needed to qualify a reverberation chamber for broadband acoustic source measurements. The SD_{max} for different source locations in ISO 3741 does not exceed 1.5 in the 100 Hz - 160 Hz one-third octave bands, 1.0 in the 200 Hz - 630 Hz one-third octave bands, 0.5 in the 800 Hz - 2500 Hz bands and 1.0 in the 3150 Hz - 10000 Hz one-third octave bands. The SD_{L4} and SD_{L5} sound pressure level results for ten microphones and one source location each are plotted along with the SD_{max} values in Figure 18, showing that for all one-third octave bands from 80 Hz to 8000 Hz the SD values are lower than the ISO 3741 limits.

Room Absorption

The absorption of the chamber may be calculated assuming that the sound field is diffuse. The equivalent sound absorption area A [m²] is defined by¹

$$A = \frac{55.3V}{cT} - 4Vm \quad (13)$$

where T is the reverberation time [s] and m is the atmospheric absorption correction term [1/m]. The value of m is dependent on the temperature, relative humidity and atmospheric pressure and can be calculated from the power attenuation coefficient α_c [dB/m] for atmospheric absorption¹⁶. The power attenuation coefficient was computed using the formulae presented in the ISO 6913 International Standard¹⁶ and is tabulated in Table 15 along with the atmospheric absorption correction term $4Vm$.

The average Sabine absorption coefficient $\bar{\alpha}$ is calculated by dividing the equivalent sound absorption area by the total surface area of the chamber

$$\bar{\alpha} = \frac{A}{S} \quad (14)$$

Table 16 list the mean values of the twelve integrated impulse response EDT and T_{20} reverberation times, the equivalent sound absorption areas and the averaged Sabine absorption coefficients for

measurement Configurations A. The averaged Sabine absorption coefficients based on the EDT and T_{20} are in reasonable agreement with one another. The average absorption coefficients in the table are not accurate for the non-diffuse field below the Schröder frequencies in Table 12. The maximum equivalent sound absorption areas A_{max} allowed by ISO 354¹ for a chamber volume of 279 m³, when performing sound absorption measurements, are listed in Table 16 showing that none of the computed equivalent sound absorption areas over the frequency range of interest (80 Hz - 8000 Hz) exceeds these limits.

ASTM International Standard E-90¹⁷ stipulates that the sound absorption area A_{limit} in the reverberation chamber (receiving room) should be less than

$$A_{limit} = \frac{V^{2/3}}{3} \quad (15)$$

for frequencies between the Schröder frequency $f=2000/V^{1/3}$ and 2000 Hz. Above 2000 Hz the sound absorption A_{limit} may be somewhat higher due to atmospheric absorption. Below the Schröder frequency it is desirable to have a higher sound absorption, but which should be limited to three times the value in Equation (15). The limiting values of A_{limit} are listed in Table 16 and are well above the sound absorption areas for the reverberation chamber.

The averaged sound absorption coefficients $\bar{\alpha}(EDT)$ and $\bar{\alpha}(T_{20})$ in Table 16 for Configuration A do not exceed $\bar{\alpha}_{max}=0.16$ in the one-third octave bands below the Schröder frequency, nor do they exceed $\bar{\alpha}_{max}=0.06$ above the Schröder frequency, thereby conforming to the requirements in ISO 3741³ for broadband measurements.

The mean values of the twelve integrated impulse response EDT and T_{20} reverberation times, the equivalent sound absorption areas and the averaged Sabine absorption coefficients for measurement Configurations B-D are listed in Table A18-Table A20 of the Appendix.

Sound Field Diffusers

Measurements of sound absorption coefficients of test specimen, sound power emission of sound sources, and the sound transmission loss of test panels require a diffuse sound field in the reverberation chamber. The Schröder frequency for a modal overlap index of greater than three indicates (Table 12) that the reverberation chamber sound field is not diffuse for the 315 Hz and lower one-third octave bands. The minimum frequency at which the sound field in the chamber is diffuse can be lowered by reducing the reverberation time to increase the modal overlap. This may be accomplished by the introduction of arrays of hanging, reflective panels or large, reflecting, moving vanes in the reverberation chamber.¹⁰ For one-third-octave bands with mid-band frequencies below 1000 Hz, it is recommended that the reverberation time T satisfies the following inequality

$$T < V \left(\frac{f}{1000} \right)^2 \quad (16)$$

The maximum recommended reverberation time as function of the one-third octave band center frequency is listed in the last column of Table 12, which indicates that the chamber is not diffuse enough in the one-third octave bands 200 Hz and lower.

Stationary diffusing panels – The ASTM standards in References 17 and 18 recommend about three to six panels suspended in random orientations throughout the room. The sheets may be corrugated or slightly curved. The panel dimensions should be about one-half to one wavelength at the lowest test

band, which would equate to 1.93 to 3.85 m for the 100 Hz one-third octave band. Panels with dimensions of 1.9 m by 3.8 m would have a reflecting sound area of 7.22 m² per side. The recommended mass per unit area is 5 kg/m². Panels are often made of plywood, particleboard¹⁷ or rigid laminated plastic sheets.¹⁹ Reference 19 suggests an optimum area S_{opt} for the diffuser panels of

$$S_{opt} = 0.04V^{2/3} \quad (17)$$

which would result in an area of 1.71 m² (one side) for the 279 m³ SALT reverberation chamber. The reverberation chamber in Reference 19 is roughly the same volume (294 m³) and 28 panels with an area of 1.5 m² each on one side were installed to improve the diffusivity of the sound field. The reverberation times in the chamber were shortened by 27% to 16% over the 100 Hz to 500 Hz frequency range.¹⁹ Please note that the optimum panel size given above is independent of frequency compared to the wavelength dependency recommended in the ASTM standard.¹⁷ The total surface area added by the diffusers recommended by the ASTM standards is 86.6 m² compared with a (comparable) diffuser area of 84 m² in Reference 19.

Moving Diffusers – The effective diffusivity of the reverberation chamber can also be improved by large, reflecting, moving panels which continuously shift both the modal frequencies and the sound incidence angles during measurements.¹⁰ The ASTM standard recommends the same size and mass-per-unit-area for the moving panels as for the stationary diffusers.¹⁷ This agrees with the recommendations in Reference 10 which suggests a 3.85 m minimum dimension for the lowest band frequency of 89 Hz in the 100 Hz one-third octave band and a panel surface weight of about 4.90 kg/m². The movement of the diffuser should be designed such that a complete cycle is completed during the time a measurement is performed. The diffuser should be non-symmetrical and oriented such that it would interrupt all significant room modes.

Diffusivity Summary

The reverberation chamber in the SALT facility can be used for several different acoustic measurements, including sound power source measurements, test specimen acoustic absorption measurements and transmission loss experiments among others. For each of these measurements equations are used which assume a diffuse field in the reverberation chamber. The Schröder frequency¹⁴ is widely accepted as a frequency above which the sound field is diffuse and can be characterized by statistical properties. However, depending on the type of measurements, instrumentation setup, and sound source and transducer locations reliable measurements may also be made in some one-third octave bands below this frequency. A summary of several criteria in the International Standards and open literature that define the one-third octave band frequency range for which different measurements are valid is presented in Table 17. It is advised that the qualification measurements recommended in each of the International Standards be conducted to ensure the reverberation chamber meets the requirements for a particular type measurement, test configuration and instrumentation setup.

CONCLUSIONS

Measurements were conducted and results were analyzed to characterize different measurement configurations of the Structural Acoustic Loads and Transmission (SALT) facility at NASA Langley Research Center. Reverberation time measurements were performed using the integrated impulse response method. Four configurations, with either an insert installed in the transmission loss (TL) window or offset from the frame, and with or without the large 35 Hz and 160 Hz cut-off frequency horns in the chamber were considered. All distances between sound sources, microphones and chamber

boundaries were compliant with the International Standards over the frequency range of interest, which includes the one-third octave bands with center frequencies from 80 Hz to 8000 Hz. One-third octave band reverberation time and sound pressure level measurements were conducted and standard deviations from the mean were computed. The dynamic range between the limited bandwidth noise burst signals and the background noise was significantly higher than the required 35 dB in all one-third octave bands. The acoustic field in the chamber was characterized in terms of one-third octave band reverberation times and the related overall acoustic absorption coefficients of the chamber were calculated. It was concluded that a diffuse field could be produced in the reverberation chamber above the Schröder frequency in the 400 Hz one-third octave band and higher for all applications. This frequency could be lowered by installing panel diffusers or large, reflecting, moving vanes to improve the acoustic modal overlap in the chamber. In the one third octave bands with center frequencies from 80 Hz to 400 Hz a successful measurement will be dependent on the type of measurement, the test configuration, the source and microphone locations and the desired accuracy. It is recommended that qualification measurements endorsed in the International Standards be conducted for each particular application.

ACKNOWLEDGEMENTS

This work was performed under the Analytical Mechanics Associates, Inc. NASA Technology Engineering Aerospace Mission Support 2 (TEAMS2) Dr. Randolph H. Cabell, Technical Direction Notice (TDN) owner.

REFERENCES

1. ISO International Standard. Acoustics - Measurement of Sound Absorption in a Reverberation Room. ISO 354:2003(E), Second Edition. International Organization for Standardization, Genève, 2003.
2. ISO International Standard. Acoustics Measurement of the Reverberation Time of Rooms with Reference to Other Acoustical Parameters. ISO 3382:2009-06-15 International Organization for Standardization, Genève, 1997.
3. ISO International Standard. Acoustics – Determination of sound power levels and sound energy levels of noise sources using sound pressure –Precision methods for reverberation test rooms. ISO 3741:2010 / ANSI/ASA S12.51-2012. International Organization for Standardization, Genève, 2010.
4. Brüel & Kjær Modular Precision Sound Level Meter Plus Reverberation Processor Module - Instruction Manual. Brüel & Kjær, DK-2850 Nærum, Denmark, April 1991.
5. Schröder, M. R.: New Method for Measuring Reverberation Time. J. Acoust. Soc. Am. 37, 409–412, 1965.
6. Barron, M.: Interpretation of early decay times in concert auditoria. *Acustica*, 81:320–331, 1995.
7. ISO International Standard. Accuracy (trueness and precision) of Measurement Methods and Results-Part 2: Basic method for the determination of repeatability and reproducibility of a standard measurement method. ISO 5725-2:1994. International Organization for Standardization, Genève, 2002.
8. ISO International Standard. Acoustics - Measurement of Sound Insulation in Buildings and of Building Elements - Parts 1-10. ISO 140:1997 (E). International Organization for Standardization, Genève, 1997.
9. Kuttruff, Heinrich: *Room Acoustics*. Applied Science Publishers Ltd. London, 1973.
10. Schultz, T. J.: Diffusion in Reverberation Rooms. J. Sound and Vibration, Vol. 16, Issue 1, May 1971, pp. 17-28.
11. Morse, P. M.: *Vibration and Sound*. McGraw-Hill, New York , 1948.

12. Bolt, R. H.: Note on Normal Frequency Statistics for Rectangular Rooms. *J. Acoust. Soc. Am.* 18 (1), 1946, pp 130–133.
13. Walker R.: Low-frequency room responses: Part 2, calculations and measurements. BBC Research and Development Department Report RD1992/9, 1992.
14. Schroeder, M. R.: The Schroeder frequency revisited. *J. Acoust. Soc. Am.* 99, 1996, pp 3240–3241.
15. Skålevik, Magne, Brekke & Strand Akustikk: Schroeder Frequency Revisited. 6th Forum Acusticum 2011, Aalborg, Denmark, 26 June 1 July 2011.
16. ISO International Standard. Acoustics – Attenuation of Sound during Propagation Outdoors – Part 1: Calculation of the absorption of sound by the atmosphere. ISO 9613-1:1993(E), First Edition. International Organization for Standardization, Genève, 1993.
17. ASTM International Standard. Standard Test Method for Laboratory Measurement of Airborne Sound Transmission Loss of Building Partitions and Elements. Designation E90 -09. American Society for Testing and Materials, West Conshohocken, Pennsylvania, USA, July 2009.
18. ASTM International Standard. Standard Test Method for Sound Absorption and Sound Absorption Coefficients by the Reverberation Room Method. Designation C423 -09a. American Society for Testing and Materials, West Conshohocken, Pennsylvania, USA, October 2009.
19. Skalov, A. D.: Reverberation Measurements of Sound Absorption in Materials. *Izmeritel'naya Tekhnika*, No 10, October 1965, pp. 24-26.

TABLES

Table 1. Nominal reverberation chamber geometric properties.

Width	w	[m]	6.4
Length	l	[m]	9.7
Height	h	[m]	4.5
Perimeter	P	[m]	82.4
Surface area	S	[m ²]	269
Volume	V	[m ³]	279

Table 2. Ambient test conditions in the reverberation chamber.

Temperature	[°C]	25.3±0.2
Dew point	[°C]	18.7
Relative Humidity	[%]	62.7
Barometric Pressure	[Pa]	101300

Table 3. Reverberation time measurements chamber configurations.

Configuration	MDF insert in the TL window		Large 35 Hz horn		Small 160 Hz horn	
	Flush	Offset (exposing gaps)	Yes	No	Yes	No
A	X			X		X
B		X		X	X	
C		X	X		X	
D	X	X	X		X	

Table 4. Mutual distances between the three microphones and their distances from the loudspeaker sources.

	Distance [m]
Speaker Box L1 - Microphone M1	2.80
Speaker Box L1 - Microphone M2	4.77
Speaker Box L1 - Microphone M3	5.93
Speaker Box L1 - Microphone M4	5.48
Speaker Box L2 - Microphone M1	3.58
Speaker Box L2 - Microphone M2	2.56
Speaker Box L2 - Microphone M3	4.55
Speaker Box L2 - Microphone M4	6.00
Speaker Box L3 - Microphone M1	7.05
Speaker Box L3 - Microphone M2	7.37
Speaker Box L3 - Microphone M3	5.52
Speaker Box L3 - Microphone M4	3.86
Microphone M1 - Microphone M2	2.22
Microphone M1 - Microphone M3	3.30
Microphone M1 - Microphone M4	3.37
Microphone M2 - Microphone M3	2.16
Microphone M2 - Microphone M4	3.68
Microphone M3 - Microphone M4	2.23

Table 5. Dynamic range between the maximum impulse noise level and the background noise levels in the reverberation chamber.

One-third Octave Band Center Frequency [Hz]	Lowest Frequency Wavelength [m]	Maximum Impulse Noise Level [dB]	Background Noise Level [dB]	Dynamic Range [dB]
80	4.84	96.7	32.2	64.5
100	3.85	97.4	33.1	64.3
125	3.06	92.3	27.8	64.5
160	2.43	88.4	25.2	63.2
200	1.93	83.6	24.1	59.5
250	1.53	84.5	23.4	61.1
315	1.22	85.2	21.2	64.0
400	0.97	81.1	19.2	61.9
500	0.77	79.8	15.0	64.8
630	0.61	78.3	14.9	63.4
800	0.48	75.6	14.1	61.5
1000	0.38	73.8	13.8	60.0
1250	0.31	71.5	11.0	60.5
1600	0.24	66.4	10.2	56.2
2000	0.19	64.8	10.4	54.4
2500	0.15	64.6	11.8	52.8
3150	0.12	63.8	10.2	53.6
4000	0.10	62.9	12.4	50.5
5000	0.08	60.1	12.2	47.9
6300	0.06	57.0	13.5	43.5
8000	0.05	55.2	12.4	42.8

Table 6. Instrumentation and equipment for the reverberation measurements.

Description	Manufacturer	Model/ Type	Serial Number	ECN/ Calibration	Calibration Date	Notes
½-inch Random Incidence Condenser Microphone	Brüel & Kjær	4134	478911	A014662	03/10/10	
Modular Precision Sound Level Meter	Brüel & Kjær	2231	1413682	A038138	03/10/10	
1/3-1/1 Octave Band Pass Filter	Brüel & Kjær	1625	1418440	A033054	02/22/10	
Reverberation Processor Module	Brüel & Kjær	BZ 7108				
Input Stage	Brüel & Kjær	ZC0020				
BNC to Mini Cable	Brüel & Kjær	AO173				
Magnetic Field Power Amplifier	Carver	TMF-42	42K70641			375 W RMS into 8-ohm 20-20kHz (<0.5% THD)
Two-way Speaker Box	JBL Professional	JBL JRX115	P0368-21351			250 W Continuous 38 Hz – 16 kHz (–10 dB) 98 dB, 1 Watt @ 1 Meter Crossover 1.6 kHz

Table 7. EDT reverberation times for four measurements (Configuration A) at microphone M3 and source location L1, their mean and their standard deviation (SD).

One-third Octave Band Center Frequency [Hz]	EDT measurements [s]				Mean [s]	SD [s]
	1	2	3	4		
80	10.84	10.78	10.84	10.82	10.82	0.03
100	11.05	11.17	11.13	11.05	11.10	0.06
125	12.12	12.24	12.13	12.12	12.15	0.06
160	12.45	12.72	12.69	12.61	12.62	0.12
200	10.79	10.95	10.90	10.84	10.87	0.07
250	9.77	9.84	9.86	9.84	9.83	0.04
315	10.33	10.38	10.30	10.24	10.31	0.06
400	9.51	9.63	9.59	9.65	9.59	0.06
500	8.39	8.40	8.42	8.42	8.41	0.02
630	7.44	7.50	7.49	7.48	7.48	0.03
800	6.48	6.44	6.44	6.44	6.45	0.02
1000	6.10	6.09	6.08	6.03	6.07	0.03
1250	5.66	5.68	5.57	5.65	5.64	0.05
1600	4.97	4.96	4.96	4.95	4.96	0.01
2000	4.56	4.60	4.59	4.57	4.58	0.02
2500	3.93	3.91	3.89	3.88	3.90	0.02
3150	3.49	3.49	3.49	3.49	3.49	0.00
4000	2.87	2.87	2.88	2.87	2.87	0.01
5000	2.08	2.06	2.07	2.08	2.07	0.01
6300	1.63	1.62	1.63	1.62	1.62	0.01
8000	1.27	1.25	1.24	1.23	1.25	0.02

Table 8. T_{20} reverberation times for four measurements (Configuration A) at microphone M3 and source location L1, their mean and their standard deviation (SD).

One-third Octave Band Center Frequency [Hz]	T_{20} measurements [s]				Mean [s]	SD [s]
	1	2	3	4		
80	10.16	10.09	10.08	10.08	10.10	0.04
100	13.17	13.43	13.32	13.11	13.26	0.15
125	13.44	13.61	13.63	13.67	13.59	0.10
160	13.45	13.75	13.83	13.76	13.70	0.17
200	12.00	12.12	12.12	12.04	12.07	0.06
250	10.90	10.87	10.89	10.88	10.88	0.01
315	10.50	10.45	10.40	10.37	10.43	0.06
400	9.78	9.64	9.66	9.73	9.70	0.06
500	8.05	8.10	8.06	8.07	8.07	0.02
630	7.47	7.52	7.54	7.54	7.52	0.03
800	6.73	6.80	6.81	6.78	6.78	0.04
1000	6.23	6.25	6.25	6.22	6.24	0.02
1250	5.86	5.89	5.78	5.82	5.84	0.05
1600	5.12	5.08	5.06	5.01	5.07	0.05
2000	4.64	4.57	4.58	4.57	4.59	0.03
2500	3.81	3.80	3.80	3.81	3.80	0.01
3150	3.37	3.42	3.41	3.42	3.40	0.02
4000	2.94	2.93	2.93	2.92	2.93	0.01
5000	2.20	2.18	2.21	2.20	2.20	0.01
6300	1.64	1.68	1.68	1.68	1.67	0.02
8000	1.28	1.31	1.32	1.30	1.30	0.02

Table 9. Minimum distances to avoid the effects from direct radiated sound, based on the Configuration A mean EDT and the T_{20} reverberation times.²

One-third Octave Band Center Frequency [Hz]	d_{\min} [m]	
	EDT	T_{20}
80	0.50	0.47
100	0.54	0.50
125	0.52	0.50
160	0.50	0.49
200	0.54	0.51
250	0.56	0.54
315	0.56	0.56
400	0.58	0.58
500	0.63	0.63
630	0.66	0.65
800	0.71	0.70
1000	0.73	0.72
1250	0.75	0.75
1600	0.80	0.80
2000	0.84	0.84
2500	0.92	0.93
3150	0.98	0.97
4000	1.08	1.06
5000	1.26	1.24
6300	1.44	1.42
8000	1.64	1.60

Table 10. Calculated acoustic modes assuming a rectangular reverberation chamber without splayed walls.

One-third Octave Band Center Frequency [Hz]	One-third Octave Band Number	Length Mode n_x	Width Mode n_y	Height Mode n_z	Modal Frequency [Hz]	Number of Modes in Band
16	12	1	0	0	17.7	1
25	14	0	1	0	26.8	1
31.5	15	1	1	0	32.1	2
31.5	15	2	0	0	35.4	2
40	16	0	0	1	38.1	3
40	16	1	0	1	42.0	3
40	16	2	1	0	44.4	3
50	17	0	1	1	46.6	5
50	17	1	1	1	49.8	5
50	17	2	0	1	52.0	5
50	17	3	0	0	53.0	5
50	17	0	2	0	53.6	5
63	18	1	2	0	56.4	9
63	18	2	1	1	58.5	9
63	18	3	1	0	59.4	9
63	18	2	2	0	64.2	9
63	18	3	0	1	65.3	9
63	18	0	2	1	65.8	9
63	18	1	2	1	68.1	9
63	18	3	1	1	70.6	9
63	18	4	0	0	70.7	9

Table 10. (cont.) Calculated acoustic modes assuming a rectangular reverberation chamber without splayed walls.

One-third Octave Band Center Frequency [Hz]	One-third Octave Band Number	Length Mode n_x	Width Mode n_y	Height Mode n_z	Modal Frequency [Hz]	Number of Modes in Band
80	19	2	2	1	74.7	18
80	19	3	2	0	75.4	18
80	19	4	1	0	75.6	18
80	19	0	0	2	76.2	18
80	19	1	0	2	78.2	18
80	19	4	0	1	80.3	18
80	19	0	3	0	80.4	18
80	19	0	1	2	80.8	18
80	19	1	3	0	82.3	18
80	19	1	1	2	82.7	18
80	19	2	0	2	84.0	18
80	19	3	2	1	84.5	18
80	19	4	1	1	84.7	18
80	19	2	3	0	87.8	18
80	19	2	1	2	88.2	18
80	19	0	5	0	88.4	18
80	19	4	2	0	88.7	18
80	19	0	3	1	89.0	18
100	20	1	3	1	90.7	24
100	20	5	1	0	92.4	24
100	20	3	0	2	92.9	24
100	20	0	2	2	93.2	24
100	20	1	2	2	94.8	24
100	20	2	3	1	95.7	24
100	20	5	0	1	96.3	24
100	20	3	3	0	96.3	24
100	20	4	2	1	96.6	24
100	20	3	1	2	96.7	24
100	20	2	2	2	99.7	24
100	20	5	1	1	99.9	24
100	20	5	2	0	103.4	24
100	20	3	3	1	103.6	24
100	20	4	0	2	104.0	24
100	20	6	0	0	106.1	24
100	20	4	3	0	107.1	24
100	20	0	4	0	107.2	24
100	20	3	2	2	107.2	24
100	20	4	1	2	107.4	24
100	20	1	4	0	108.6	24
100	20	6	1	0	109.4	24
100	20	5	2	1	110.2	24
100	20	0	3	2	110.8	24
125	21	1	3	2	112.2	55
125	21	6	0	1	112.7	55
125	21	2	4	0	112.9	55
125	21	4	3	1	113.7	55
125	21	0	4	1	113.8	55
125	21	0	0	3	114.3	55
125	21	1	4	1	115.1	55

Table 10. (cont.) Calculated acoustic modes assuming a rectangular reverberation chamber without splayed walls.

One-third Octave Band Center Frequency [Hz]	One-third Octave Band Number	Length Mode n_x	Width Mode n_y	Height Mode n_z	Modal Frequency [Hz]	Number of Modes in Band
125	21	1	0	3	115.7	55
125	21	6	1	1	115.9	55
125	21	2	3	2	116.3	55
125	21	5	0	2	116.7	55
125	21	4	2	2	117.0	55
125	21	0	1	3	117.4	55
125	21	1	1	3	118.8	55
125	21	6	2	0	118.9	55
125	21	2	4	1	119.1	55
125	21	5	3	0	119.5	55
125	21	3	4	0	119.6	55
125	21	2	0	3	119.7	55
125	21	5	1	2	119.8	55
125	21	2	1	3	122.6	55
125	21	3	3	2	122.8	55
125	21	7	0	0	123.8	55
125	21	6	2	1	124.8	55
125	21	5	3	1	125.4	55
125	21	3	0	3	126.0	55
125	21	0	2	3	126.3	55
125	21	7	1	0	126.6	55
125	21	1	2	3	127.5	55
125	21	4	4	0	128.4	55
125	21	5	2	2	128.4	55
125	21	3	1	3	128.9	55
125	21	7	0	1	129.5	55
125	21	6	0	2	130.6	55
125	21	2	2	3	131.1	55
125	21	4	3	2	131.4	55
125	21	0	4	2	131.5	55
125	21	7	1	1	132.2	55
125	21	1	4	2	132.7	55
125	21	6	3	0	133.1	55
125	21	6	1	2	133.3	55
125	21	3	4	1	134.0	55
125	21	4	4	1	134.0	55
125	21	0	5	0	134.0	55
125	21	4	0	3	134.4	55
125	21	7	2	0	134.9	55
125	21	1	5	0	135.1	55
125	21	2	4	2	136.2	55
125	21	3	2	3	137.0	55
125	21	4	1	3	137.1	55
125	21	6	3	1	138.5	55
125	21	2	5	0	138.6	55
125	21	5	4	0	138.9	55
125	21	0	5	1	139.3	55
125	21	0	3	3	139.8	55

Table 10. (cont.) Calculated acoustic modes assuming a rectangular reverberation chamber without splayed walls.

One-third Octave Band Center Frequency [Hz]	One-third Octave Band Number	Length Mode n_x	Width Mode n_y	Height Mode n_z	Modal Frequency [Hz]	Number of Modes in Band
125	21	2	4	1	119.1	55
125	21	5	3	0	119.5	55
125	21	3	4	0	119.6	55
125	21	2	0	3	119.7	55
125	21	5	1	2	119.8	55
125	21	2	1	3	122.6	55
125	21	3	3	2	122.8	55
125	21	7	0	0	123.8	55
125	21	6	2	1	124.8	55
125	21	5	3	1	125.4	55
125	21	3	0	3	126.0	55
125	21	0	2	3	126.3	55
125	21	7	1	0	126.6	55
125	21	1	2	3	127.5	55
125	21	4	4	0	128.4	55
125	21	5	2	2	128.4	55
125	21	3	1	3	128.9	55
125	21	7	0	1	129.5	55
125	21	6	0	2	130.6	55
125	21	2	2	3	131.1	55
125	21	4	3	2	131.4	55
125	21	0	4	2	131.5	55
125	21	7	1	1	132.2	55
125	21	1	4	2	132.7	55
125	21	6	3	0	133.1	55
125	21	6	1	2	133.3	55
125	21	3	4	1	134.0	55
125	21	4	4	1	134.0	55
125	21	0	5	0	134.0	55
125	21	4	0	3	134.4	55
125	21	7	2	0	134.9	55
125	21	1	5	0	135.1	55
125	21	2	4	2	136.2	55
125	21	3	2	3	137.0	55
125	21	4	1	3	137.1	55
125	21	6	3	1	138.5	55
125	21	2	5	0	138.6	55
125	21	5	4	0	138.9	55
125	21	0	5	1	139.3	55
125	21	0	3	3	139.8	55

Table 11. Calculated modal density assuming a rectangular reverberation chamber without splayed walls.

One-third Octave Band Center Frequency [Hz]	Modal Density [1/Hz]	One-third Octave Band Center Frequency [Hz]	Modal Density [1/Hz]
80	0.9	1000	90.2
100	1.3	1250	139.8
125	1.8	1600	227.4
160	2.8	2000	353.5
200	4.2	2500	550.1
250	6.3	3150	870.3
315	9.8	4000	1399.5
400	15.3	5000	2182.3
500	23.5	6300	3458.7
630	36.7	8000	5569.3
800	58.3	10000	8693.1

Table 12. The uniform distribution minimum frequencies and Schröder diffuse field cut-off frequencies as function of the Configuration A mean reverberation times.

One-third Octave Band Center Frequency [Hz]	Mean Reverberation Time T_{20} [s]	Minimum Frequency f_{min} [Hz]	Schröder Cut-off Frequency f_s [Hz]	Maximum Reverberation Time ² below 1000 Hz [s]
80	14.81	206.8	483.2	1.8
100	12.81	192.4	449.4	2.8
125	13.14	194.8	455.0	4.4
160	13.61	198.3	463.2	7.1
200	12.41	189.3	442.2	11.2
250	10.95	177.9	415.5	17.4
315	10.44	173.6	405.6	27.7
400	9.79	168.1	392.7	44.6
500	8.13	153.3	358.0	69.8
630	7.65	148.7	347.3	110.7
800	6.70	139.1	324.8	178.6
1000	6.19	133.7	312.3	
1250	5.79	129.3	302.2	
1600	5.10	121.4	283.5	
2000	4.55	114.6	267.8	
2500	3.78	104.5	244.2	
3150	3.45	99.8	233.1	
4000	2.86	90.9	212.4	
5000	2.12	78.3	182.9	
6300	1.62	68.3	159.6	
8000	1.26	60.3	140.9	

Table 13. Instrumentation and equipment for the sound pressure level measurements.

Description	Manufacturer	Model/ Type	Serial Numbers	ECN/ Calibration	Notes
½-inch Prepolarized Condenser Microphones	G.R.A.S.	40AO	58461-58464, 58466-58468, 58470-58472		
½-inch Microphone Preamplifiers	G.R.A.S.	26CA	48291-48294, 48296-48298, 48300-48302		
ICP Signal Conditioner	PCB Piezotronics	584A	1004	A033091	
Multi-Channel Amplifier	Rane	MA6S	174373		150 watts per Channel @ 4 ohms (20-20 kHz)
Signal Switching System	Precision Filters	PF 464K	481A-261	1656103	
Smart Office Analyzer	M+P International		2379		Version 4.1
Chassis with Dynamic Signal Acquisition Modules	National Instruments	NI PXI-1045 NI PXI-4472B (3)		3048604	
Random Noise Generator	General Radio	1382	01793	M94274	Random signal with flat power spectral density
Acoustical Calibrator	Brüel & Kjær	4231	2242297	A029503	
Two-way Speaker Box	JBL Professional	JBL JRX115	P0368-21351		250 W Continuous 38 Hz – 16 kHz (–10 dB) 98 dB, 1 Watt @ 1 Meter Crossover 1.6 kHz

Table 14. Computed standard deviations for eight repeated measurements by ten microphones (SD_1 - SD_{10}) with the source at location L3, the total SD at locations L3 and L4, and the maximum allowed in ISO 3741.³

One-third Octave Band [Hz]	SD_1	SD_2	SD_3	SD_4	SD_5	SD_6	SD_7	SD_8	SD_9	SD_{10}	Total SD_{L4}	Total SD_{L5}	SD_{Max}
80	0.97	1.08	0.62	1.02	1.01	0.68	1.24	0.94	1.21	0.97	1.35	0.82	1.5
100	1.00	0.76	1.77	0.88	0.95	1.02	0.72	0.85	0.76	1.00	0.70	1.40	1.5
125	0.61	0.59	0.89	0.54	0.60	0.99	0.86	1.02	0.74	0.72	1.11	1.15	1.5
160	0.58	1.03	0.74	1.05	0.93	1.20	0.73	0.93	0.94	0.92	0.84	0.72	1.0
200	0.88	0.37	0.38	0.92	0.32	0.49	0.63	0.46	0.46	0.87	0.70	0.68	1.0
250	0.64	0.56	0.62	0.75	0.36	0.62	0.52	0.54	0.30	0.50	0.58	0.31	1.0
315	0.22	0.42	0.40	0.48	0.54	0.55	0.38	0.32	0.26	0.37	0.45	0.50	1.0
400	0.52	0.41	0.23	0.58	0.61	0.39	0.53	0.65	0.46	0.41	0.35	0.39	1.0
500	0.33	0.30	0.32	0.47	0.30	0.25	0.33	0.39	0.24	0.39	0.60	0.44	1.0
630	0.27	0.28	0.13	0.37	0.25	0.30	0.44	0.30	0.35	0.29	0.31	0.29	0.5
800	0.36	0.30	0.39	0.17	0.35	0.41	0.32	0.24	0.33	0.32	0.49	0.33	0.5
1000	0.22	0.30	0.30	0.18	0.22	0.23	0.21	0.36	0.25	0.26	0.31	0.23	0.5
1250	0.22	0.31	0.18	0.38	0.31	0.28	0.25	0.21	0.26	0.26	0.19	0.28	0.5
1600	0.13	0.22	0.22	0.25	0.12	0.19	0.07	0.22	0.10	0.18	0.25	0.29	0.5
2000	0.21	0.16	0.24	0.17	0.16	0.21	0.15	0.15	0.13	0.17	0.22	0.29	0.5
2500	0.18	0.11	0.12	0.14	0.25	0.22	0.14	0.15	0.14	0.12	0.43	0.23	1.0
3150	0.18	0.10	0.13	0.10	0.18	0.17	0.17	0.17	0.18	0.18	0.28	0.25	1.0
4000	0.08	0.13	0.15	0.20	0.18	0.11	0.17	0.21	0.16	0.12	0.26	0.23	1.0
5000	0.12	0.16	0.10	0.09	0.07	0.15	0.10	0.10	0.06	0.09	0.39	0.43	1.0
6300	0.15	0.15	0.12	0.14	0.13	0.11	0.17	0.09	0.10	0.10	0.64	0.43	1.0
8000	0.09	0.03	0.11	0.11	0.07	0.08	0.07	0.09	0.08	0.06	0.71	0.54	1.0

Table 15. Calculated power attenuation coefficient¹⁶ α_c and the atmospheric absorption correction term 4mV.

One-third Octave Band Center Frequency [Hz]	α_c [dB/m]	4mV [m ²]
80	0.0001	0.03
100	0.0002	0.05
125	0.0003	0.08
160	0.0005	0.13
200	0.0008	0.20
250	0.0011	0.29
315	0.0017	0.43
400	0.0024	0.61
500	0.0032	0.81
630	0.0041	1.05
800	0.0051	1.31
1000	0.0061	1.57
1250	0.0072	1.84
1600	0.0086	2.21
2000	0.0103	2.65
2500	0.0128	3.29
3150	0.0167	4.28
4000	0.0229	5.89
5000	0.0321	8.24
6300	0.0469	12.05
8000	0.0712	18.31

Table 16. Equivalent sound absorption area and averaged Sabine absorption coefficient for Configuration A.

One-third Octave Band Center Frequency [Hz]	Mean Reverberation Time		Equivalent Sound Absorption Area ¹		ISO 354 ¹	ASTM E-90 ¹⁷	Averaged Sabine Absorption Coefficient		ISO 3147 ³
	EDT [s]	T ₂₀ [s]	A(EDT) [m ²]	A(T ₂₀) [m ²]	A _{max} [m ²]	A _{limit} [m ²]	$\bar{\alpha}$ (EDT)	$\bar{\alpha}$ (T ₂₀)	$\bar{\alpha}_{max}$
80	12.75	14.81	3.48	2.99		42.7	0.01	0.01	0.16
100	11.14	12.81	3.97	3.44	8.1	42.7	0.01	0.01	0.16
125	12.08	13.14	3.63	3.33	8.1	42.7	0.01	0.01	0.16
160	12.79	13.61	3.37	3.16	8.1	42.7	0.01	0.01	0.16
200	11.31	12.41	3.76	3.41	8.1	42.7	0.01	0.01	0.16
250	10.33	10.95	4.04	3.80	8.1	42.7	0.02	0.01	0.16
315	10.22	10.44	3.96	3.87	8.1	42.7	0.01	0.01	0.16
400	9.56	9.79	4.08	3.97	8.1	14.2	0.02	0.01	0.06
500	8.22	8.13	4.64	4.69	8.1	14.2	0.02	0.02	0.06
630	7.52	7.65	4.90	4.80	8.1	14.2	0.02	0.02	0.06
800	6.51	6.70	5.57	5.38	8.1	14.2	0.02	0.02	0.06
1000	6.04	6.19	5.84	5.67	8.7	14.2	0.02	0.02	0.06
1250	5.75	5.79	5.94	5.89	9.4	14.2	0.02	0.02	0.06
1600	5.01	5.10	6.74	6.57	10.0	14.2	0.03	0.02	0.06
2000	4.55	4.55	7.19	7.19	11.9	14.2	0.03	0.03	0.06
2500	3.81	3.78	8.46	8.55	13.1		0.03	0.03	0.06
3150	3.38	3.45	8.98	8.71	15.0		0.03	0.03	0.06
4000	2.80	2.86	10.12	9.76	16.2		0.04	0.04	0.06
5000	2.05	2.12	13.58	12.86	17.5		0.05	0.05	0.06
6300	1.56	1.62	16.63	15.66			0.06	0.06	0.06
8000	1.21	1.26	18.76	17.25			0.07	0.06	0.06

Table 17. Summary of several criteria in the International Standards and literature that define the range of one-third octave bands for which measurements in the reverberation chamber are valid.

Criterion	Reference	#	Requirement	Reverberation Chamber Reference	Valid One-third Octave Band Frequency Range
Chamber volume	ISO 3741	[3]	>200 m ³	279 m ³	≥100 Hz
Number of room modes per third octave band	Schultz	[10]	Equation (6)	Table 10	≥100 Hz
Uniform frequency distribution	Morse	[11]	Equation (7)	Table 12	≥200 Hz
Chamber dimension ratio's	ISO 354 Walker	[1] [13]	Equation (8) Equation (9)	Figure 15	≥80 Hz
Schröder cut-off frequency	Schröder	[14]	Equation (10)	Table 12	≥400 Hz
Schröder frequency revisited	Skålevik et. al.	[15]	0.5 Schröder frequency	Table 12	≥200 Hz
Standard deviation reverberation times	ISO 354	[1]	Equation (11)	Figure 16	≥250 Hz
Standard deviation sound pressure levels	ISO 3741	[3]	Equation (12)	Table 14 Figure 18	≥80 Hz
Equivalent sound absorption area	ISO 354 ASTM E-90	[1] [17]	Table 16 Equation (15)	Table 16	≥80 Hz
Averaged sound absorption coefficient	ISO 3741	[3]	Table 16	Table 16	≥80 Hz

FIGURES

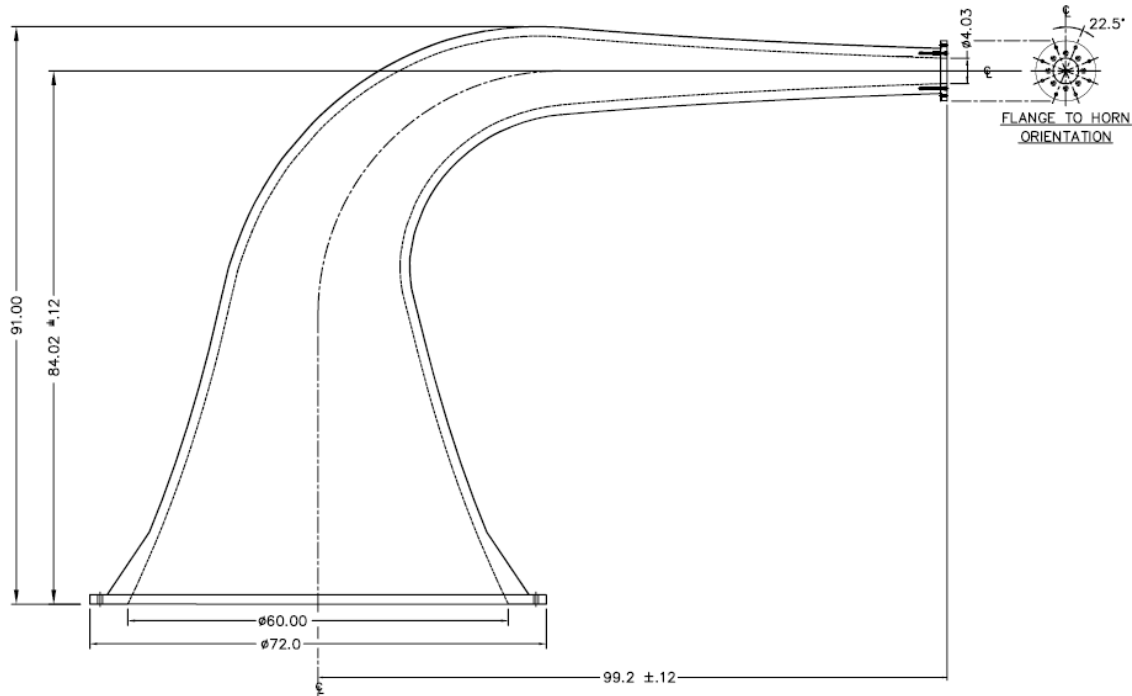

Figure 1. The large 35 Hz cut-off frequency exponential horn.

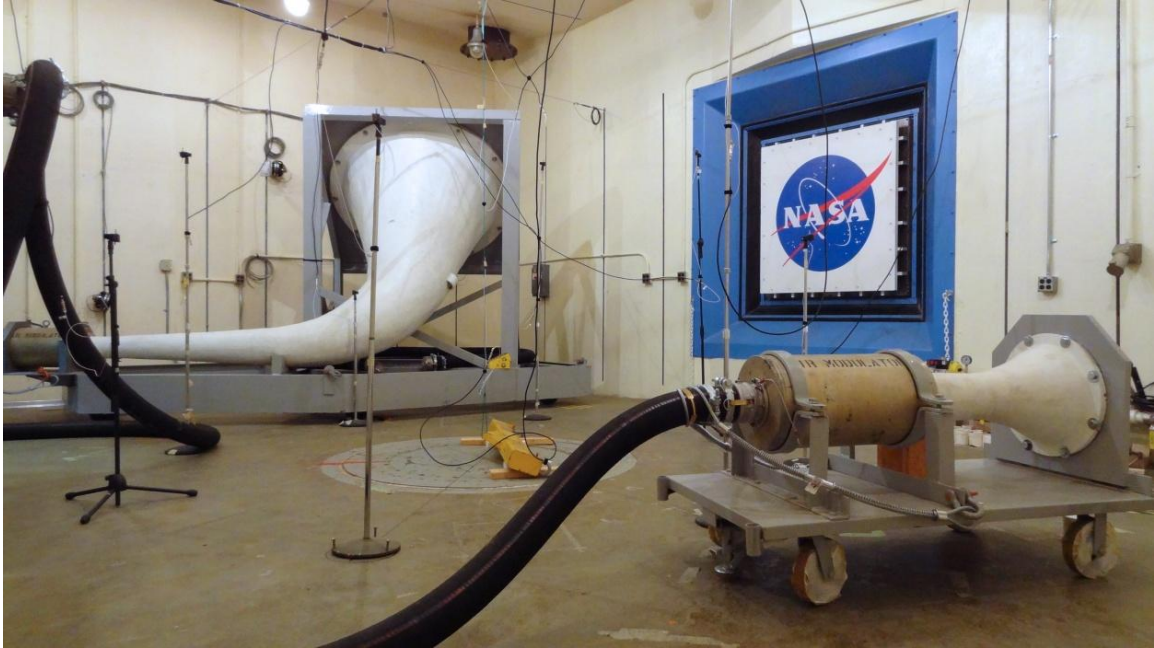

Figure 2. The large 35 Hz cut-off frequency horn and the small 160 Hz cut-off frequency horn (foreground) in the reverberation chamber. The 38 mm thick MDF panel with the NASA logo is offset from the TL window to leave breaches along its four sides allowing air flow to escape to the adjacent anechoic chamber (Configuration C). For reverberation measurements in the empty chamber without the two horns, the offset panel is replaced by a 57 mm thick MDF panel mounted flush in the transmission loss window (Configuration A).

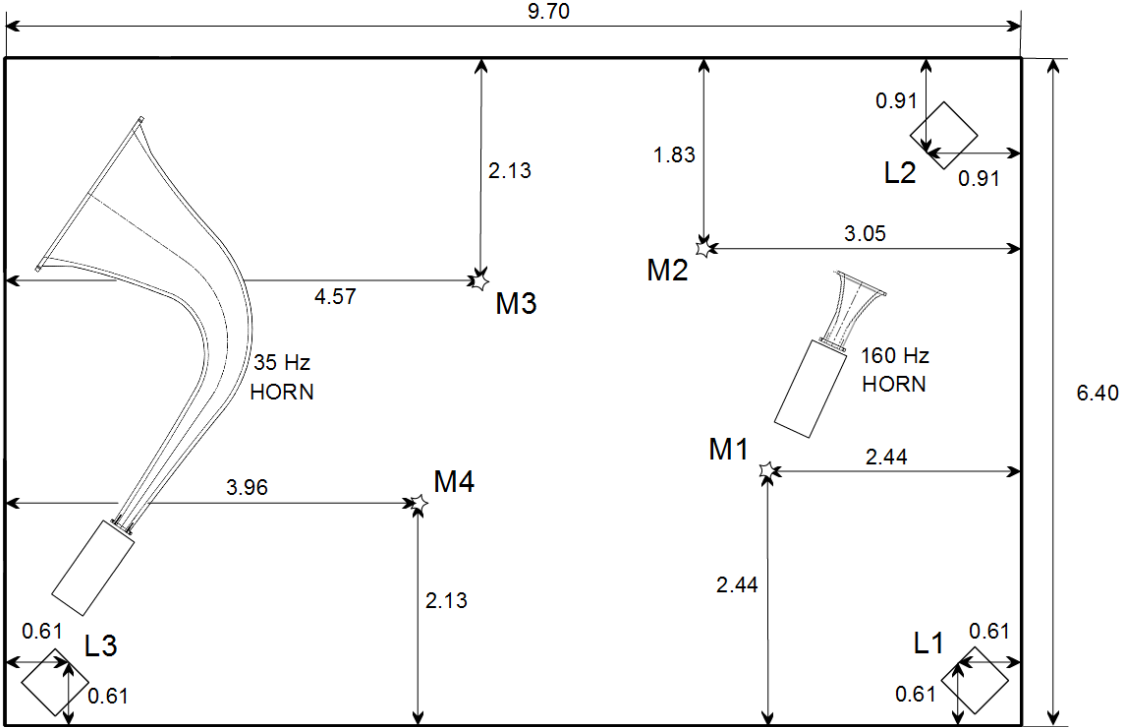

Figure 3. Sketch of the reverberation chamber layout showing the three loudspeaker (L1-L3) and the four microphone locations (M1-M4).



Figure 4. Brüel & Kjær Type 2231 Modular Precision Sound Level Meter with the Type 1625 One-Third Octave Filter Set and the Type BZ7108 Reverberation Processor.

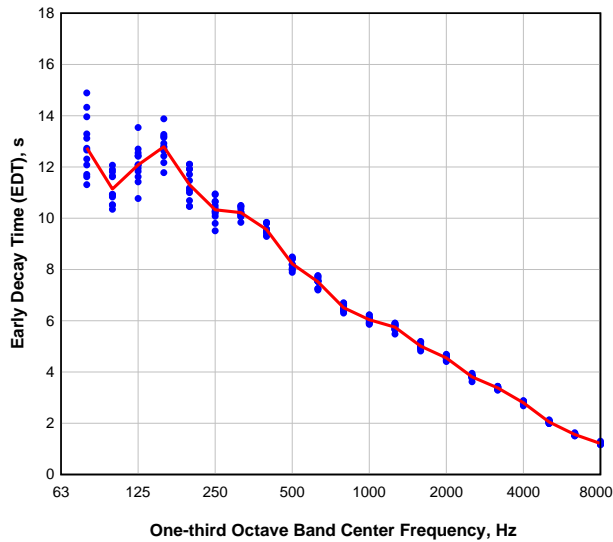

Figure 5. Twelve measured EDT reverberation times and their mean (solid line) with the MDF insert mounted flush in the TL window but without the two horns in the chamber (Configuration A).

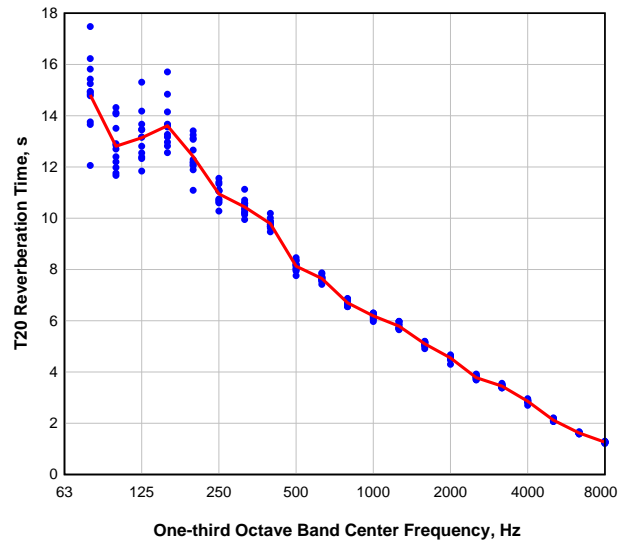

Figure 6. Twelve measured T_{20} reverberation times and their mean (solid line) with the MDF insert mounted flush in the TL window but without the two horns in the chamber (Configuration A).

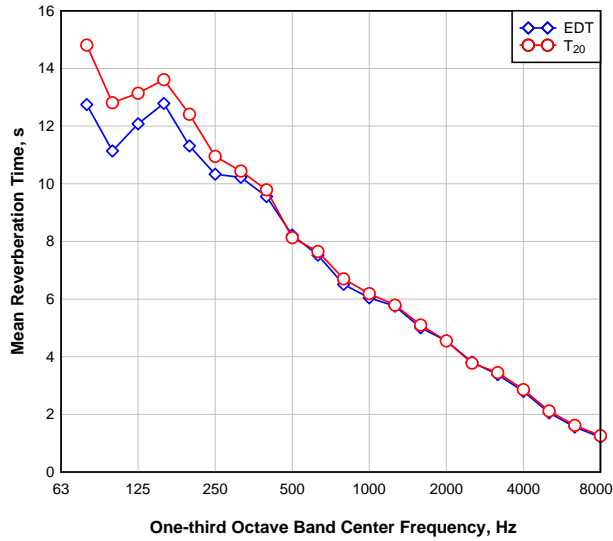

Figure 7. Mean measured EDT and T_{20} reverberation times with the MDF insert mounted flush in the TL window but without the two horns (Configuration A).

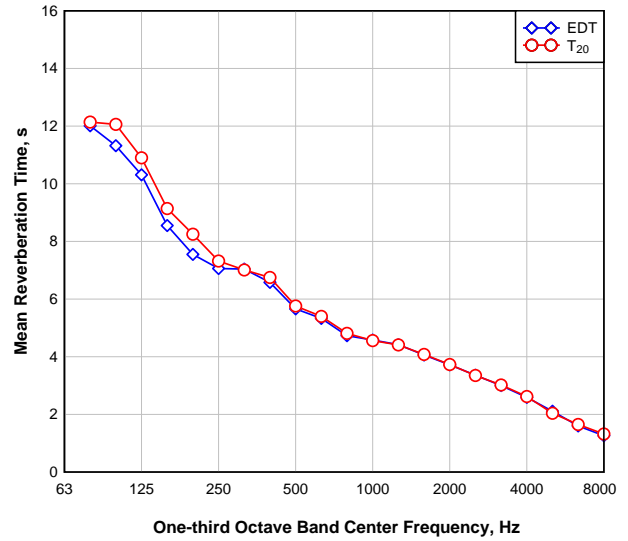

Figure 8. Mean measured EDT and T_{20} reverberation times with the MDF offset in front of the TL window (exposing gaps) including the 160 Hz horn, but without the 35 Hz horn (Configuration B).

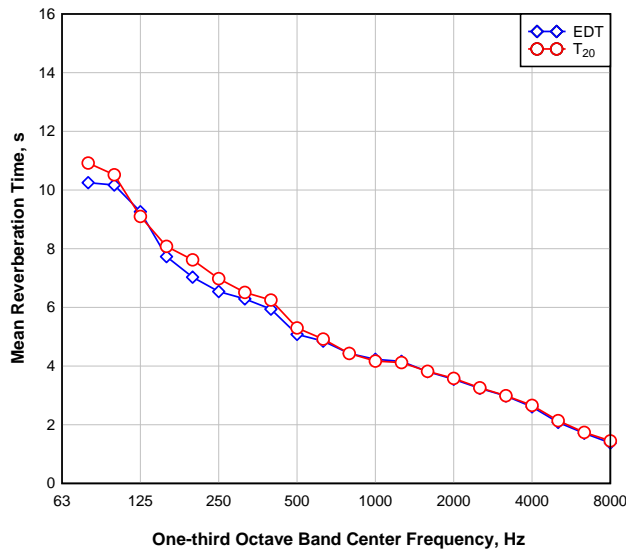

Figure 9. Mean measured EDT and T_{20} reverberation times with the MDF offset in front of the TL window (exposing gaps) and the two horns deployed (Configuration C).

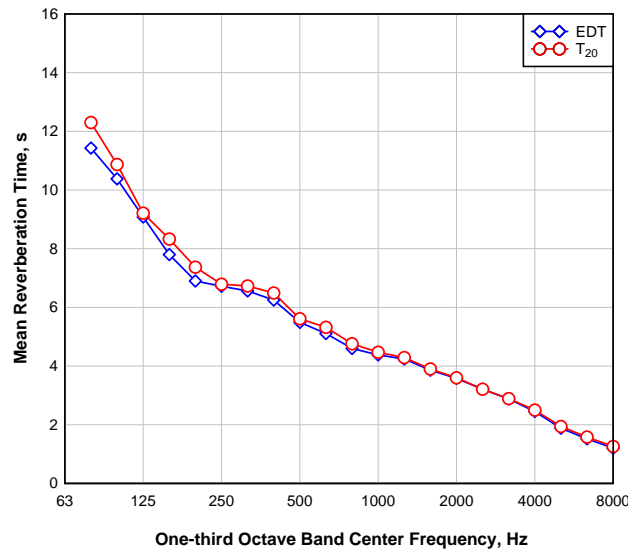

Figure 10. Mean measured EDT and T_{20} reverberation times with the offset and flush MDF panels mounted and the two horns deployed (Configuration D).

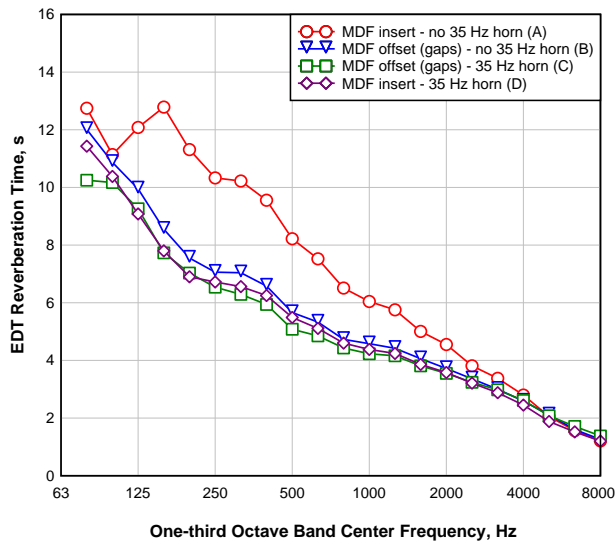

Figure 11. Mean measured EDT reverberation times for Configurations A-D.

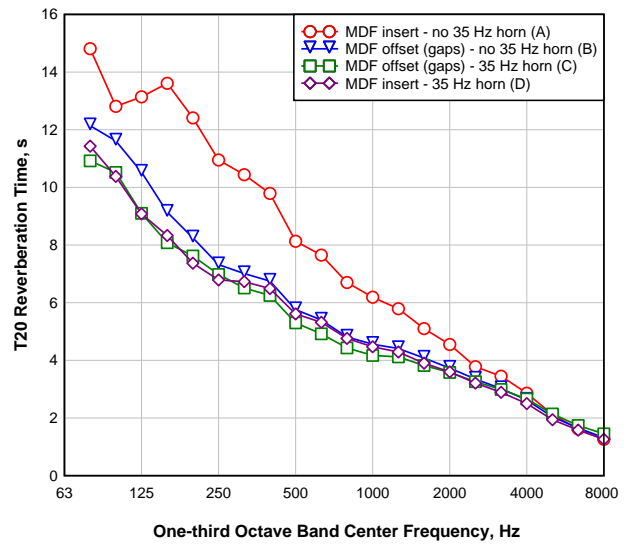

Figure 12. Mean measured T_{20} reverberation times for Configurations A-D.

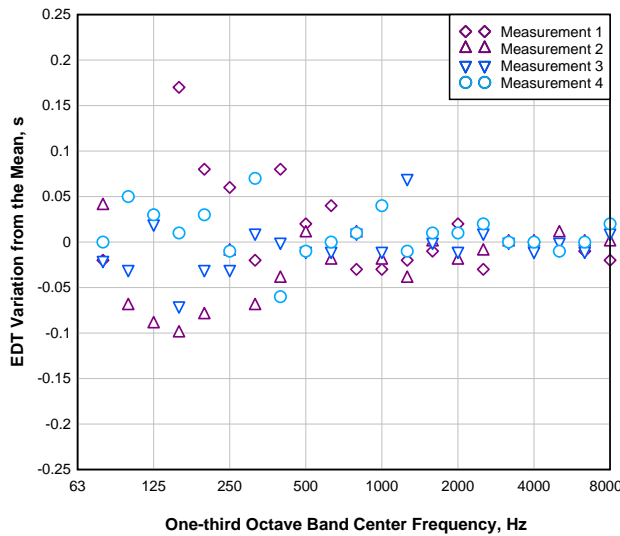

Figure 13. Measured EDT reverberation time variations from the mean over four repeated measurements for Configuration A at microphone M3 and source location L1.

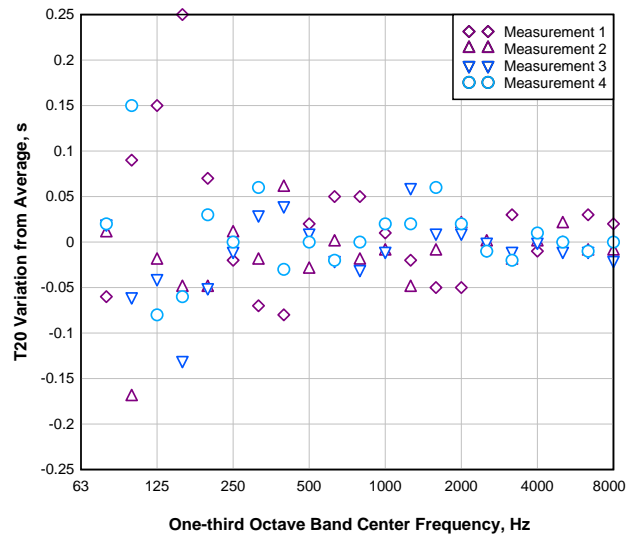

Figure 14. Measured T_{20} reverberation time variations from the mean over four repeated measurements for Configuration A at microphone M3 and source location L1.

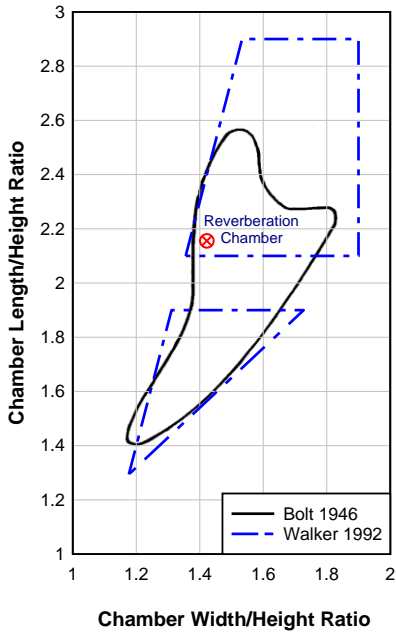

Figure 15. Bolt¹² room proportion criterion showing curve enclosing rectangular room dimension ratios yielding the smoothest frequency response at low frequencies.

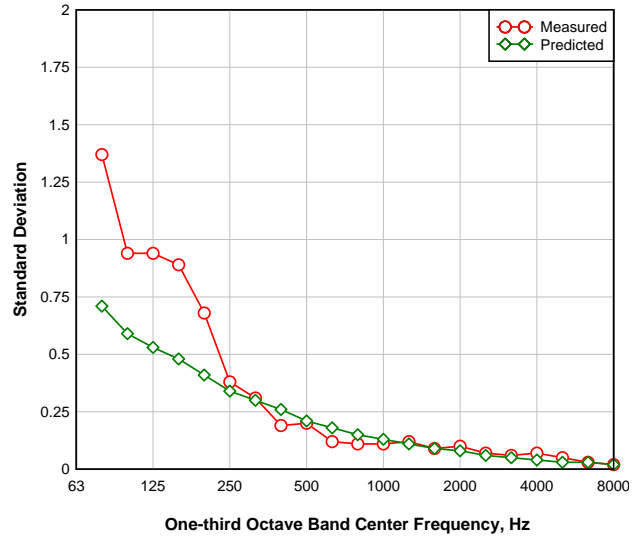

Figure 16. Measured and ISO 354 estimated¹ standard deviations of twelve T_{20} reverberation times for Configuration A.

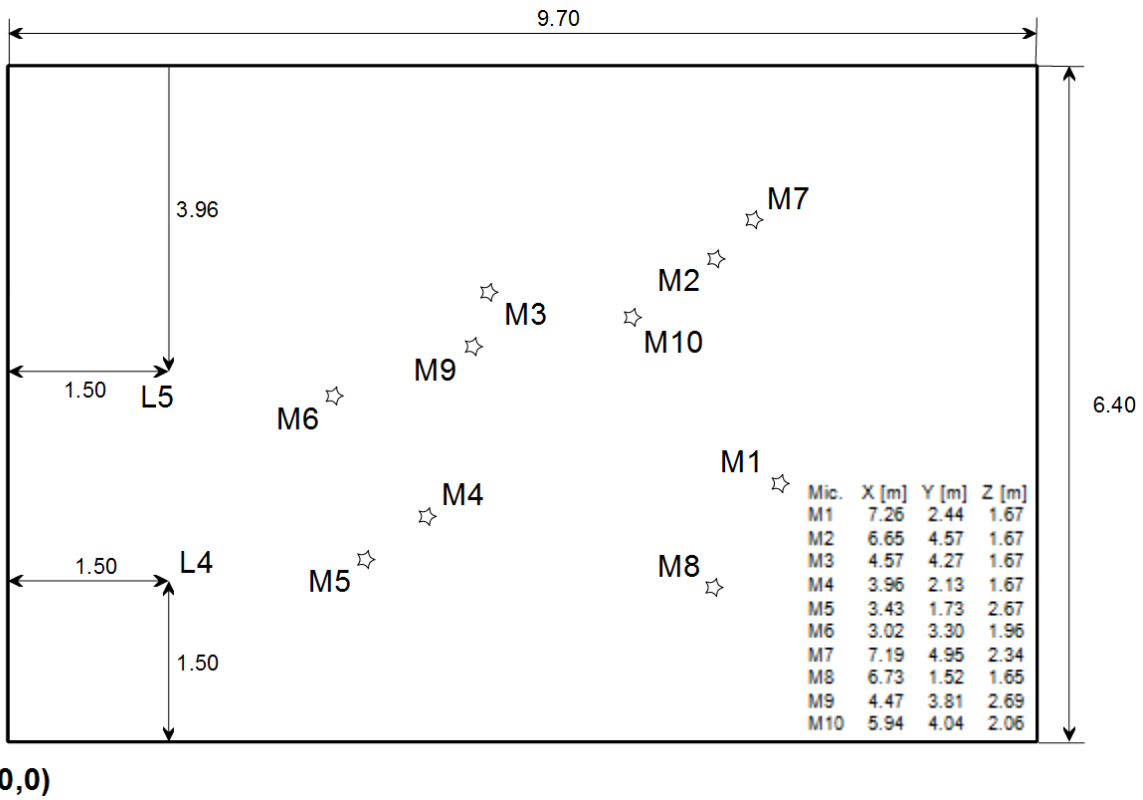

Figure 17. Sketch of the reverberation chamber layout for the ten-microphone variability measurements showing the two loudspeaker (L4 and L5) and the ten microphone (M1-M10) locations.

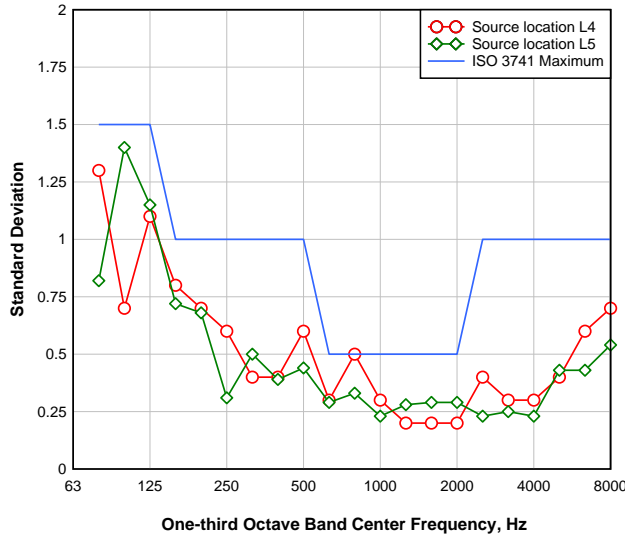

Figure 18. Total standard deviation (SD) of the sound pressure levels for ten microphones at two “white” noise sound source locations, and the maximum SD in the International Standard ISO 3741.³

APPENDIX

Table A1. EDT and T_{20} integrated impulse response reverberation times for source location L1 (Configuration A).

One-third Octave Band Center Frequency [Hz]	EDT [s]				T_{20} [s]			
	M1	M2	M3	M4	M1	M2	M3	M4
80	13.12	12.08	11.71	13.96	13.66	14.92	12.06	14.95
100	12.07	10.51	10.93	11.65	12.85	11.98	12.91	14.12
125	11.62	11.83	12.07	12.44	12.55	12.33	13.47	14.18
160	12.17	13.27	12.43	12.64	12.82	13.27	13.58	14.15
200	11.18	12.10	10.69	10.47	12.66	13.12	11.89	11.09
250	10.27	10.26	9.80	9.51	11.08	11.56	10.6	10.28
315	10.44	10.36	10.18	9.84	10.39	11.13	10.33	9.95
400	9.54	9.57	9.58	9.29	9.68	10.19	9.67	9.47
500	8.17	7.98	8.43	7.89	8.35	8.16	8.07	8.15
630	7.53	7.26	7.54	7.20	7.65	7.83	7.58	7.53
800	6.60	6.41	6.47	6.61	6.73	6.87	6.81	6.55
1000	5.89	5.92	6.01	5.86	6.30	6.22	6.26	6.04
1250	5.67	5.67	5.65	5.48	5.65	5.97	5.84	5.68
1600	4.82	4.98	4.93	4.95	4.91	5.13	5.05	5.00
2000	4.53	4.65	4.59	4.44	4.30	4.67	4.57	4.54
2500	3.82	3.85	3.84	3.62	3.77	3.92	3.81	3.69
3150	3.31	3.36	3.44	3.33	3.38	3.49	3.42	3.42
4000	2.68	2.73	2.81	2.73	2.70	2.81	2.85	2.85
5000	2.06	1.99	2.02	1.99	2.12	2.08	2.07	2.10
6300	1.59	1.54	1.60	1.51	1.59	1.62	1.61	1.60
8000	1.20	1.21	1.22	1.16	1.25	1.21	1.24	1.24

Table A2. EDT and T₂₀ integrated impulse response reverberation times for source location L2 (Configuration A).

One-third Octave Band Center Frequency [Hz]	EDT [s]				T ₂₀ [s]			
	M1	M2	M3	M4	M1	M2	M3	M4
80	12.31	12.73	13.29	14.89	15.82	15.25	16.23	17.48
100	10.35	10.93	11.81	11.62	11.67	12.40	13.51	14.32
125	12.70	12.55	12.42	13.54	13.67	12.81	13.16	15.31
160	13.15	13.20	12.80	13.88	14.84	13.65	13.67	15.71
200	11.92	11.92	11.00	11.09	13.41	13.08	12.20	13.25
250	10.92	10.49	10.38	10.08	11.34	11.10	10.75	11.41
315	10.24	10.06	10.47	10.50	10.59	10.59	10.50	10.71
400	9.47	9.84	9.34	9.80	9.77	9.70	9.87	9.75
500	8.46	8.49	8.41	8.05	8.46	8.20	7.76	8.02
630	7.66	7.76	7.75	7.25	7.64	7.42	7.59	7.66
800	6.66	6.41	6.68	6.30	6.65	6.55	6.66	6.57
1000	6.05	6.08	6.22	6.11	6.26	6.29	6.30	6.17
1250	5.71	5.84	5.81	5.91	5.70	5.87	5.72	5.69
1600	5.05	4.96	5.02	5.00	5.14	5.18	5.15	5.20
2000	4.46	4.41	4.58	4.53	4.60	4.50	4.62	4.59
2500	3.79	3.81	3.89	3.75	3.75	3.89	3.77	3.71
3150	3.40	3.40	3.44	3.29	3.51	3.51	3.39	3.38
4000	2.85	2.87	2.88	2.80	2.88	2.96	2.92	2.87
5000	2.13	2.07	2.12	2.08	2.08	2.12	2.19	2.10
6300	1.63	1.58	1.56	1.58	1.59	1.65	1.67	1.60
8000	1.30	1.22	1.18	1.19	1.30	1.24	1.28	1.28

Table A3. EDT and T₂₀ integrated impulse response reverberation times for source location L3 (Configuration A).

One-third Octave Band Center Frequency [Hz]	EDT [s]				T ₂₀ [s]			
	M1	M2	M3	M4	M1	M2	M3	M4
80	11.31	14.33	11.62	12.66	14.78	15.43	13.76	14.84
100	11.90	10.83	10.88	10.53	14.07	11.76	12.70	12.20
125	12.09	11.42	11.95	10.77	13.45	12.39	13.17	11.84
160	12.92	12.69	12.77	11.78	12.56	13.56	13.17	12.97
200	12.11	11.71	10.46	11.47	12.09	12.29	12.16	12.05
250	10.95	10.19	10.66	10.64	10.71	10.65	11.06	11.06
315	10.17	10.15	10.23	10.07	10.21	10.23	10.57	10.14
400	9.44	9.53	9.48	9.83	9.86	9.87	10.01	9.62
500	8.41	8.21	8.00	8.19	8.35	7.99	8.21	7.94
630	7.70	7.58	7.54	7.56	7.87	7.72	7.68	7.71
800	6.42	6.50	6.38	6.70	6.80	6.85	6.63	6.70
1000	5.94	6.12	6.23	6.12	6.08	5.97	6.24	6.14
1250	5.90	5.81	5.85	5.78	5.73	5.75	5.97	5.98
1600	5.19	5.13	5.18	4.89	5.05	5.18	5.13	5.09
2000	4.67	4.55	4.69	4.53	4.62	4.57	4.57	4.47
2500	3.85	3.95	3.80	3.79	3.82	3.81	3.70	3.79
3150	3.39	3.37	3.42	3.40	3.39	3.56	3.44	3.49
4000	2.84	2.78	2.82	2.80	2.88	2.92	2.89	2.85
5000	2.07	2.05	2.07	2.00	2.17	2.16	2.21	2.08
6300	1.55	1.56	1.51	1.54	1.58	1.61	1.64	1.64
8000	1.25	1.18	1.18	1.22	1.28	1.27	1.26	1.27

Table A4. Four-microphone mean EDT and T_{20} for the three source locations L1, L2 and L3 (Configuration A).

One-third Octave Band Center Frequency [Hz]	Mean EDT [s]				Mean T_{20} [s]			
	L1	L2	L3	L1-L3	L1	L2	L3	L1-L3
80	12.66	13.24	12.37	12.75	13.79	16.15	14.68	14.81
100	11.26	11.15	11.01	11.14	12.92	12.90	12.63	12.81
125	11.98	12.79	11.53	12.08	13.09	13.67	12.68	13.14
160	12.61	13.25	12.52	12.79	13.44	14.42	13.06	13.61
200	11.08	11.47	11.40	11.31	12.14	12.97	12.15	12.41
250	9.95	10.46	10.60	10.33	10.86	11.14	10.87	10.94
315	10.20	10.31	10.15	10.22	10.43	10.60	10.28	10.44
400	9.49	9.61	9.57	9.56	9.75	9.77	9.84	9.79
500	8.11	8.35	8.20	8.22	8.18	8.10	8.12	8.13
630	7.38	7.60	7.59	7.52	7.65	7.58	7.74	7.65
800	6.52	6.51	6.50	6.51	6.74	6.61	6.74	6.70
1000	5.92	6.11	6.10	6.04	6.20	6.25	6.11	6.19
1250	5.62	5.82	5.83	5.75	5.78	5.74	5.86	5.79
1600	4.92	5.01	5.09	5.01	5.02	5.17	5.11	5.10
2000	4.55	4.49	4.61	4.55	4.52	4.58	4.56	4.55
2500	3.78	3.81	3.85	3.81	3.80	3.78	3.78	3.78
3150	3.36	3.38	3.39	3.38	3.43	3.45	3.47	3.45
4000	2.74	2.85	2.81	2.80	2.80	2.91	2.88	2.86
5000	2.01	2.10	2.05	2.05	2.09	2.12	2.15	2.12
6300	1.56	1.59	1.54	1.56	1.60	1.63	1.62	1.62
8000	1.20	1.22	1.21	1.21	1.23	1.27	1.27	1.26

Table A5. Standard deviation (SD) of EDT and T_{20} for the three source locations L1, L2 and L3 (Configuration A)

One-third Octave Band Center Frequency [Hz]	Standard Deviation (EDT)				Standard Deviation T_{20}			
	L1	L2	L3	L1-L3	L1	L2	L3	L1-L3
80	1.02	1.13	1.37	1.13	1.37	0.95	0.69	1.37
100	0.70	0.67	0.60	0.61	0.88	1.18	1.00	0.94
125	0.35	0.51	0.60	0.70	0.86	1.11	0.74	0.94
160	0.47	0.45	0.52	0.55	0.56	1.00	0.42	0.89
200	0.72	0.51	0.70	0.62	0.89	0.54	0.11	0.68
250	0.37	0.35	0.31	0.43	0.56	0.30	0.22	0.38
315	0.27	0.21	0.07	0.19	0.49	0.09	0.19	0.31
400	0.14	0.25	0.18	0.18	0.31	0.07	0.16	0.19
500	0.24	0.20	0.17	0.21	0.12	0.30	0.19	0.20
630	0.18	0.24	0.07	0.19	0.13	0.11	0.09	0.12
800	0.10	0.19	0.14	0.13	0.14	0.06	0.10	0.11
1000	0.06	0.07	0.12	0.12	0.11	0.06	0.11	0.11
1250	0.09	0.08	0.05	0.12	0.15	0.08	0.14	0.12
1600	0.07	0.04	0.14	0.11	0.09	0.03	0.06	0.09
2000	0.09	0.08	0.08	0.09	0.16	0.05	0.06	0.10
2500	0.11	0.06	0.07	0.08	0.10	0.08	0.05	0.07
3150	0.06	0.06	0.02	0.05	0.05	0.07	0.07	0.06
4000	0.05	0.04	0.03	0.06	0.07	0.04	0.03	0.07
5000	0.03	0.03	0.03	0.05	0.02	0.05	0.05	0.05
6300	0.04	0.03	0.02	0.04	0.01	0.04	0.03	0.03
8000	0.03	0.05	0.03	0.04	0.02	0.03	0.01	0.02

Table A6. EDT and T₂₀ integrated impulse response reverberation times for source location L1 (Configuration B).

One-third Octave Band Center Frequency [Hz]	EDT [s]				T ₂₀ [s]			
	M1	M2	M3	M4	M1	M2	M3	M4
80	11.66	11.55	12.32	13.29	11.37	11.22	14.62	15.49
100	9.42	11.23	10.74	11.12	10.69	11.42	12.18	12.59
125	9.18	9.01	10.49	10.10	10.00	9.25	10.24	10.06
160	8.98	8.39	8.71	8.82	9.83	8.64	8.66	9.05
200	7.15	7.87	7.42	7.90	8.26	9.11	8.87	8.68
250	7.32	7.20	7.00	7.06	7.53	7.59	7.44	8.14
315	7.41	6.80	7.28	6.78	7.05	7.05	7.26	7.41
400	6.23	6.76	6.63	6.48	6.90	6.77	7.00	6.98
500	5.46	5.72	5.78	5.73	5.73	5.65	5.70	5.77
630	5.34	5.45	5.77	5.29	5.40	5.35	5.22	5.48
800	4.66	4.89	5.01	4.79	4.94	4.78	4.78	4.83
1000	4.55	4.51	4.65	4.57	4.56	4.45	4.61	4.55
1250	4.26	4.45	4.67	4.65	4.14	4.33	4.53	4.34
1600	4.04	4.06	4.08	4.19	4.10	3.90	4.16	4.13
2000	3.65	3.64	3.78	3.79	3.79	3.71	3.73	3.77
2500	3.36	3.30	3.35	3.38	3.40	3.42	3.38	3.29
3150	2.96	2.91	2.97	3.11	3.11	3.05	3.07	3.01
4000	2.57	2.56	2.55	2.74	2.62	2.68	2.62	2.69
5000	2.00	1.99	1.98	2.06	1.99	2.07	2.05	2.11
6300	1.61	1.65	1.54	1.65	1.67	1.64	1.66	1.70
8000	1.27	1.32	1.20	1.30	1.34	1.31	1.33	1.34

Table A7. EDT and T₂₀ integrated impulse response reverberation times for source location L2 (Configuration B).

One-third Octave Band Center Frequency [Hz]	EDT [s]				T ₂₀ [s]			
	M1	M2	M3	M4	M1	M2	M3	M4
80	10.89	11.86	12.85	12.88	10.04	11.39	13.64	14.36
100	11.73	10.88	11.76	11.31	12.03	10.77	12.86	13.51
125	10.93	9.72	11.20	10.64	13.00	9.79	11.94	11.79
160	8.31	8.39	8.69	7.84	9.79	8.95	9.23	8.80
200	6.92	7.73	7.51	7.09	8.06	7.82	8.05	7.51
250	7.30	7.03	6.69	6.79	7.50	7.34	7.22	6.81
315	8.08	6.61	6.98	6.98	7.02	6.78	6.99	6.84
400	7.32	6.75	6.62	6.66	6.45	6.60	6.67	6.67
500	5.63	5.88	5.77	5.29	5.84	5.89	5.90	5.75
630	5.14	5.37	5.28	5.04	5.47	5.54	5.44	5.23
800	4.68	4.31	4.86	4.77	4.87	4.89	4.77	4.81
1000	4.59	4.38	4.62	4.75	4.56	4.56	4.65	4.67
1250	4.43	4.41	4.42	4.44	4.56	4.38	4.54	4.61
1600	4.28	4.07	3.99	3.94	4.10	4.20	4.19	4.08
2000	3.86	3.61	3.80	3.65	3.62	3.70	3.74	3.69
2500	3.41	3.32	3.35	3.35	3.33	3.29	3.33	3.33
3150	3.04	3.02	3.02	2.95	2.98	2.99	2.96	2.97
4000	2.58	2.60	2.63	2.61	2.69	2.57	2.57	2.53
5000	2.02	6.01	1.97	1.94	2.01	2.04	2.06	2.03
6300	1.68	1.59	1.59	1.54	1.68	1.65	1.60	1.62
8000	1.28	1.24	1.25	1.21	1.33	1.30	1.30	1.31

Table A8. EDT and T_{20} integrated impulse response reverberation times for source location L3 (Configuration B).

One-third Octave Band Center Frequency [Hz]	EDT [s]				T_{20} [s]			
	M1	M2	M3	M4	M1	M2	M3	M4
80	11.81	12.57	11.64	11.29	11.05	11.84	12.84	10.53
100	10.84	10.77	10.87	10.22	12.11	9.75	12.21	10.38
125	10.82	8.78	10.01	9.29	12.12	9.55	10.62	9.53
160	9.23	8.12	9.00	8.30	10.19	8.84	9.40	8.60
200	8.22	7.64	7.77	7.59	8.79	8.41	8.33	7.45
250	7.18	6.99	7.26	7.00	7.52	6.96	7.39	6.67
315	6.83	6.72	7.26	6.94	7.11	6.63	7.38	6.67
400	6.36	6.12	6.62	6.53	6.92	6.71	6.79	6.56
500	5.90	5.57	5.71	5.57	5.72	5.83	5.78	5.56
630	5.46	5.16	5.45	5.30	5.38	5.41	5.50	5.36
800	4.62	4.77	4.72	4.73	4.64	4.82	4.81	4.74
1000	4.82	4.58	4.41	4.51	4.64	4.39	4.68	4.44
1250	4.53	4.31	4.20	4.35	4.34	4.37	4.42	4.42
1600	4.12	4.04	3.97	3.92	4.14	4.12	3.98	3.91
2000	3.73	3.76	3.72	3.72	3.75	3.79	3.72	3.78
2500	3.41	3.44	3.34	3.33	3.36	3.40	3.36	3.33
3150	3.04	3.06	2.94	2.94	3.07	3.01	3.02	3.03
4000	2.51	2.52	2.55	2.63	2.64	2.60	2.64	2.60
5000	1.95	1.95	2.00	2.02	2.05	2.04	2.05	2.02
6300	1.61	1.58	1.61	1.59	1.66	1.67	1.65	1.61
8000	1.25	1.27	1.27	1.27	1.31	1.34	1.33	1.29

Table A9. Mean EDT and T_{20} reverberation times for twelve measurements (Configuration B) and their standard deviation (SD).

One-third Octave Band Center Frequency [Hz]	EDT [s]		T_{20} [s]	
	Mean	SD	Mean	SD
80	12.01	0.73	12.14	1.79
100	10.87	0.64	11.61	1.12
125	9.95	0.82	10.53	1.24
160	8.55	0.41	9.14	0.53
200	7.55	0.38	8.25	0.53
250	7.06	0.20	7.32	0.39
315	7.04	0.40	7.01	0.26
400	6.58	0.30	6.75	0.17
500	5.66	0.18	5.76	0.10
630	5.33	0.19	5.40	0.10
800	4.73	0.17	4.81	0.08
1000	4.58	0.13	4.56	0.09
1250	4.42	0.14	4.41	0.13
1600	4.06	0.10	4.08	0.10
2000	3.72	0.08	3.73	0.05
2500	3.36	0.04	3.35	0.04
3150	3.00	0.06	3.02	0.05
4000	2.59	0.06	2.62	0.05
5000	2.11	1.18	2.04	0.03
6300	1.60	0.04	1.65	0.03
8000	1.26	0.03	1.32	0.02

Table A10. EDT and T_{20} integrated impulse response reverberation times for source location L1 (Configuration C).

One-third Octave Band Center Frequency [Hz]	EDT [s]				T_{20} [s]			
	M1	M2	M3	M4	M1	M2	M3	M4
80	11.05	10.84	11.00	10.87	11.25	12.27	12.88	11.14
100	10.29	10.11	9.83	10.21	10.36	11.54	10.29	10.26
125	9.53	9.09	9.16	9.46	9.32	8.88	9.15	9.02
160	8.49	7.09	8.28	8.13	8.40	9.15	8.93	8.13
200	7.12	7.27	7.48	7.00	8.02	8.18	8.03	7.47
250	6.32	7.23	6.95	6.17	6.99	7.16	7.64	6.85
315	6.24	6.74	6.39	6.03	6.59	6.50	6.71	6.53
400	5.90	6.03	5.73	6.03	6.43	6.17	6.33	6.53
500	4.83	4.83	5.14	4.90	5.16	5.00	5.28	6.11
630	4.89	4.59	4.87	4.72	4.93	4.75	4.97	5.05
800	4.56	4.45	4.50	4.41	4.32	4.30	4.40	4.86
1000	4.14	4.31	4.48	4.27	4.06	4.26	4.27	4.34
1250	4.01	4.19	4.33	4.15	4.09	4.17	4.19	4.14
1600	3.87	3.87	3.84	3.69	3.81	3.83	3.82	3.65
2000	3.55	3.61	3.60	3.47	3.45	3.55	3.60	3.53
2500	3.24	3.29	3.28	3.20	3.17	3.31	3.29	3.21
3150	3.01	2.94	3.09	2.93	2.96	3.00	2.99	2.94
4000	2.66	2.62	2.63	2.64	2.66	2.66	2.68	2.63
5000	2.05	2.08	2.07	2.05	2.09	2.10	2.12	2.16
6300	1.71	1.73	1.69	1.68	1.68	1.74	1.77	1.66
8000	1.39	1.40	1.35	1.38	1.49	1.42	1.44	1.42

Table A11. EDT and T_{20} integrated impulse response reverberation times for source location L2 (Configuration C).

One-third Octave Band Center Frequency [Hz]	EDT [s]				T_{20} [s]			
	M1	M2	M3	M4	M1	M2	M3	M4
80	10.64	11.12	10.68	8.98	11.59	10.87	10.99	9.47
100	10.87	10.19	10.80	10.45	11.47	10.58	10.66	10.27
125	9.53	9.53	10.41	10.59	9.95	9.60	9.70	9.34
160	7.90	8.08	8.20	8.12	8.27	8.40	9.07	8.13
200	7.31	6.99	6.65	6.45	7.21	7.29	7.19	7.21
250	6.59	6.62	6.44	6.16	6.70	7.10	6.84	6.78
315	6.13	6.42	6.38	6.11	6.54	6.48	6.31	6.22
400	5.81	6.00	6.19	6.02	6.33	6.16	6.00	5.91
500	5.30	5.22	5.35	5.05	5.38	5.26	5.44	5.19
630	5.12	4.70	4.99	4.91	4.93	5.05	5.04	5.01
800	4.52	4.47	4.46	4.38	4.37	4.48	4.52	4.44
1000	4.08	4.24	4.36	4.30	4.24	4.10	4.18	4.01
1250	4.20	4.03	4.28	4.21	4.15	3.86	4.20	4.16
1600	4.02	3.77	3.73	3.85	3.93	3.93	3.76	3.85
2000	3.62	3.56	3.59	3.55	3.67	3.57	3.55	3.62
2500	3.37	3.31	3.19	3.21	3.26	3.19	3.36	3.33
3150	3.11	2.99	2.94	2.94	2.95	3.00	3.02	3.05
4000	2.60	2.64	2.74	2.57	2.63	2.72	2.59	2.63
5000	2.19	2.07	2.08	2.05	2.15	2.16	2.13	2.12
6300	1.76	1.66	1.64	1.70	1.80	1.79	1.72	1.74
8000	1.38	1.35	1.34	1.39	1.44	1.52	1.43	1.44

Table A12. EDT and T_{20} integrated impulse response reverberation times for source location L3 (Configuration C).

One-third Octave Band Center Frequency [Hz]	EDT [s]				T_{20} [s]			
	M1	M2	M3	M4	M1	M2	M3	M4
80	11.39	9.11	9.08	9.25	11.56	10.38	9.43	10.24
100	10.30	9.99	9.24	9.93	10.46	10.57	9.78	10.21
125	9.69	8.55	7.80	8.57	8.78	8.61	8.80	8.36
160	8.06	6.61	6.51	8.00	7.34	7.31	7.49	7.03
200	7.83	6.58	6.65	7.29	7.91	7.73	7.33	8.13
250	6.71	6.37	6.62	6.42	7.20	6.86	6.71	7.05
315	6.15	6.19	6.43	6.30	6.33	6.66	6.35	6.92
400	5.81	5.81	5.97	5.96	6.24	6.37	6.22	6.38
500	5.09	5.26	5.00	5.02	5.28	5.11	5.37	5.14
630	5.02	4.97	4.70	4.80	4.86	4.74	5.01	4.75
800	4.31	4.40	4.38	4.30	4.24	4.45	4.45	4.43
1000	3.90	4.19	4.39	4.20	4.04	4.26	4.13	4.19
1250	4.19	4.01	4.10	4.20	4.11	4.18	4.12	4.14
1600	3.78	3.76	3.75	3.79	3.84	3.90	3.72	3.86
2000	3.51	3.48	3.53	3.51	3.62	3.62	3.57	3.64
2500	3.27	3.11	3.21	3.21	3.26	3.19	3.21	3.33
3150	2.89	2.90	2.99	3.00	3.00	2.99	3.00	3.01
4000	2.56	2.57	2.60	2.51	2.66	2.69	2.71	2.70
5000	2.11	2.09	2.10	2.04	2.18	2.15	2.15	2.14
6300	1.75	1.75	1.67	1.74	1.77	1.80	1.74	1.67
8000	1.43	1.41	1.36	1.43	1.46	1.43	1.46	1.47

Table A13. Mean EDT and T_{20} reverberation times for twelve measurements (Configuration C) and their standard deviation (SD).

One-third Octave Band Center Frequency [Hz]	EDT [s]		T_{20} [s]	
	Mean	SD	Mean	SD
80	10.25	0.93	10.92	1.03
100	10.17	0.43	10.52	0.51
125	9.26	0.78	9.10	0.47
160	7.73	0.67	8.08	0.72
200	7.03	0.41	7.62	0.40
250	6.54	0.31	6.98	0.27
315	6.29	0.19	6.51	0.20
400	5.94	0.13	6.25	0.18
500	5.08	0.18	5.30	0.28
630	4.85	0.16	4.92	0.12
800	4.43	0.08	4.43	0.16
1000	4.23	0.15	4.17	0.11
1250	4.16	0.10	4.12	0.09
1600	3.81	0.09	3.82	0.08
2000	3.55	0.05	3.58	0.06
2500	3.24	0.07	3.26	0.06
3150	2.98	0.07	2.99	0.03
4000	2.61	0.06	2.66	0.04
5000	2.08	0.04	2.14	0.03
6300	1.71	0.04	1.74	0.05
8000	1.38	0.03	1.45	0.03

Table A14. EDT and T_{20} integrated impulse response reverberation times for source location L1 (Configuration D).

One-third Octave Band Center Frequency [Hz]	EDT [s]				T_{20} [s]			
	M1	M2	M3	M4	M1	M2	M3	M4
80	12.27	10.68	10.65	12.80	13.48	12.58	11.11	13.76
100	10.41	9.40	9.36	10.53	11.03	10.56	9.49	11.24
125	9.03	7.87	8.56	8.95	9.29	8.33	8.94	8.52
160	8.44	6.98	7.68	7.62	9.50	8.44	8.77	7.89
200	7.55	6.72	7.76	7.34	6.88	7.68	7.70	7.75
250	7.04	7.06	6.92	6.31	6.60	7.12	7.15	6.88
315	6.98	6.87	6.39	6.30	6.75	6.70	6.63	6.55
400	6.31	6.26	5.93	6.11	6.58	6.36	6.32	6.40
500	5.68	5.55	5.16	5.32	5.58	5.69	5.87	5.48
630	5.06	5.17	4.86	5.32	5.43	5.32	5.35	5.29
800	4.44	4.60	4.55	4.93	4.60	4.69	4.64	4.76
1000	4.48	4.20	4.38	4.52	4.39	4.46	4.40	4.53
1250	4.22	4.04	4.38	4.27	4.19	4.10	4.24	4.45
1600	4.05	3.84	3.87	3.94	3.88	3.74	3.89	3.98
2000	3.67	3.75	3.54	3.54	3.63	3.82	3.50	3.63
2500	3.13	3.14	3.16	3.25	3.26	3.21	3.16	3.15
3150	2.81	2.87	2.76	2.94	2.86	2.89	2.88	2.92
4000	2.42	2.40	2.35	2.40	2.52	2.51	2.46	2.47
5000	1.89	1.82	1.84	1.84	1.91	1.82	1.90	1.87
6300	1.55	1.52	1.53	1.47	1.53	1.54	1.55	1.58
8000	1.20	1.22	1.15	1.13	1.22	1.22	1.23	1.26

Table A15. EDT and T_{20} integrated impulse response reverberation times for source location L2 (Configuration D).

One-third Octave Band Center Frequency [Hz]	EDT [s]				T_{20} [s]			
	M1	M2	M3	M4	M1	M2	M3	M4
80	11.42	11.27	12.21	10.78	13.41	11.47	11.60	11.15
100	11.13	10.41	11.02	10.29	11.06	11.50	11.89	10.19
125	9.54	9.49	10.05	10.13	9.29	9.27	9.84	9.79
160	7.44	7.48	8.57	8.02	7.86	8.42	8.81	8.63
200	6.18	6.31	6.48	7.01	6.77	7.15	7.81	7.05
250	6.72	6.53	6.61	6.92	6.85	6.53	7.08	6.67
315	6.57	5.94	6.72	6.44	6.70	6.56	6.99	6.79
400	6.08	6.02	6.52	6.25	6.40	6.26	6.80	6.58
500	5.60	5.61	5.51	5.57	5.50	5.38	5.57	5.67
630	5.32	5.15	5.22	5.21	5.23	5.09	5.31	5.46
800	4.46	4.63	4.60	4.60	4.84	4.81	4.93	4.93
1000	4.35	4.53	4.42	4.37	4.41	4.61	4.39	4.49
1250	4.48	4.45	4.30	4.10	4.27	4.23	4.25	4.35
1600	3.96	3.98	3.74	3.77	3.77	3.88	3.89	3.96
2000	3.51	3.56	3.60	3.62	3.54	3.64	3.55	3.73
2500	3.24	3.21	3.29	3.17	3.31	3.22	3.21	3.21
3150	2.93	2.92	2.82	2.88	2.91	2.92	2.83	2.92
4000	2.53	2.40	2.51	2.46	2.51	2.51	2.50	2.46
5000	1.84	1.89	1.87	1.86	1.94	1.91	1.99	1.92
6300	1.50	1.48	1.54	1.50	1.59	1.55	1.55	1.57
8000	1.23	1.11	1.21	1.18	1.23	1.24	1.34	1.25

Table A16. EDT and T_{20} integrated impulse response reverberation times for source location L3 (Configuration D).

One-third Octave Band Center Frequency [Hz]	EDT [s]				T_{20} [s]			
	M1	M2	M3	M4	M1	M2	M3	M4
80	11.96	10.07	11.68	12.00	11.36	10.71	14.23	14.27
100	10.79	10.73	10.29	10.50	11.32	10.99	10.32	11.33
125	9.12	9.01	8.99	8.67	9.40	9.39	9.65	9.11
160	8.43	7.34	8.53	7.48	7.43	7.50	8.35	8.84
200	6.94	6.69	7.83	6.48	7.43	7.24	7.71	7.50
250	7.05	6.41	6.85	6.35	6.66	6.57	6.90	6.59
315	6.98	6.65	6.54	6.51	6.78	6.84	7.00	6.49
400	6.49	6.49	6.34	6.21	6.72	6.68	6.36	6.44
500	5.09	5.85	5.64	5.36	5.50	5.68	5.63	5.86
630	4.89	5.25	5.13	4.78	5.22	5.34	5.27	5.52
800	4.80	4.67	4.54	4.44	4.67	4.81	4.77	4.72
1000	4.32	4.51	4.24	4.26	4.37	4.52	4.62	4.45
1250	4.04	4.23	4.12	4.25	4.49	4.36	4.34	4.19
1600	3.77	3.73	3.82	3.86	3.94	3.92	3.99	3.94
2000	3.51	3.47	3.57	3.64	3.51	3.55	3.63	3.48
2500	3.23	3.23	3.27	3.21	3.15	3.19	3.25	3.20
3150	2.86	2.91	2.92	2.97	2.91	2.86	2.89	2.92
4000	2.45	2.44	2.55	2.55	2.49	2.47	2.52	2.56
5000	2.02	1.87	1.89	1.95	2.22	1.96	1.91	1.92
6300	1.53	1.51	1.57	1.58	1.62	1.62	1.58	1.69
8000	1.22	1.25	1.22	1.25	1.28	1.29	1.27	1.30

Table A17. Mean EDT and T_{20} reverberation times for twelve measurements (Configuration D) and their standard deviation (SD).

One-third Octave Band Center Frequency [Hz]	EDT [s]		T_{20} [s]	
	Mean	SD	Mean	SD
80	11.43	0.82	12.30	1.34
100	10.38	0.55	10.87	0.66
125	9.08	0.63	9.21	0.46
160	7.80	0.54	8.33	0.61
200	6.90	0.57	7.37	0.36
250	6.72	0.28	6.79	0.23
315	6.56	0.30	6.73	0.16
400	6.25	0.19	6.49	0.17
500	5.49	0.22	5.61	0.15
630	5.11	0.18	5.32	0.12
800	4.60	0.15	4.76	0.11
1000	4.38	0.11	4.47	0.09
1250	4.24	0.15	4.29	0.11
1600	3.86	0.10	3.90	0.08
2000	3.58	0.08	3.60	0.10
2500	3.21	0.05	3.21	0.05
3150	2.88	0.06	2.89	0.03
4000	2.45	0.07	2.50	0.03
5000	1.88	0.06	1.94	0.10
6300	1.52	0.03	1.58	0.05
8000	1.20	0.05	1.26	0.04

Table A18. Equivalent sound absorption area and averaged Sabine absorption coefficient for Configuration B.

One-third Octave Band Center Frequency [Hz]	Mean Reverberation Time		Equivalent Sound Absorption Area		Averaged Sabine Absorption Coefficient	
	EDT [s]	T ₂₀ [s]	A(EDT) [m ²]	A(T ₂₀) [m ²]	$\bar{\alpha}$ (EDT)	$\bar{\alpha}$ (T ₂₀)
80	12.01	12.14	3.69	3.65	0.01	0.01
100	10.87	11.61	4.07	3.80	0.02	0.01
125	9.95	10.53	4.42	4.17	0.02	0.02
160	8.55	9.14	5.11	4.77	0.02	0.02
200	7.55	8.25	5.73	5.23	0.02	0.02
250	7.06	7.32	6.05	5.82	0.02	0.02
315	7.04	7.01	5.94	5.97	0.02	0.02
400	6.58	6.75	6.20	6.03	0.02	0.02
500	5.66	5.76	7.10	6.96	0.03	0.03
630	5.33	5.40	7.35	7.25	0.03	0.03
800	4.73	4.81	8.16	8.01	0.03	0.03
1000	4.58	4.56	8.22	8.25	0.03	0.03
1250	4.42	4.41	8.28	8.31	0.03	0.03
1600	4.06	4.08	8.83	8.76	0.03	0.03
2000	3.72	3.73	9.37	9.35	0.03	0.03
2500	3.36	3.35	10.04	10.08	0.04	0.04
3150	3.00	3.02	10.67	10.54	0.04	0.04
4000	2.59	2.62	11.43	11.21	0.04	0.04
5000	2.11	2.04	13.03	13.68	0.05	0.05
6300	1.60	1.65	15.90	15.09	0.06	0.06
8000	1.26	1.32	17.24	15.65	0.06	0.06

Table A19. Equivalent sound absorption area and averaged Sabine absorption coefficient for Configuration C.

One-third Octave Band Center Frequency [Hz]	Mean Reverberation Time		Equivalent Sound Absorption Area		Averaged Sabine Absorption Coefficient	
	EDT [s]	T ₂₀ [s]	A(EDT) [m ²]	A(T ₂₀) [m ²]	$\bar{\alpha}$ (EDT)	$\bar{\alpha}$ (T ₂₀)
80	10.25	10.92	4.33	0.03	0.02	0.02
100	10.17	10.52	4.35	0.05	0.02	0.02
125	9.26	9.10	4.75	0.08	0.02	0.02
160	7.73	8.08	5.66	0.13	0.02	0.02
200	7.03	7.62	6.17	0.20	0.02	0.02
250	6.54	6.98	6.56	0.29	0.02	0.02
315	6.29	6.51	6.70	0.43	0.02	0.02
400	5.94	6.25	6.94	0.61	0.03	0.02
500	5.08	5.30	8.01	0.81	0.03	0.03
630	4.85	4.92	8.18	1.05	0.03	0.03
800	4.43	4.43	8.80	1.31	0.03	0.03
1000	4.23	4.17	9.01	1.57	0.03	0.03
1250	4.16	4.12	8.93	1.84	0.03	0.03
1600	3.81	3.82	9.55	2.21	0.04	0.04
2000	3.55	3.58	9.97	2.65	0.04	0.04
2500	3.24	3.26	10.54	3.29	0.04	0.04
3150	2.98	2.99	10.77	4.28	0.04	0.04
4000	2.61	2.66	11.27	5.89	0.04	0.04
5000	2.08	2.14	13.28	8.24	0.05	0.05
6300	1.71	1.74	14.20	12.05	0.05	0.05
8000	1.38	1.45	14.06	18.31	0.05	0.05

Table A20. Equivalent sound absorption area and averaged Sabine absorption coefficient for Configuration D.

One-third Octave Band Center Frequency [Hz]	Mean Reverberation Time		Equivalent Sound Absorption Area		Averaged Sabine Absorption Coefficient	
	EDT [s]	T ₂₀ [s]	A(EDT) [m ²]	A(T ₂₀) [m ²]	$\bar{\alpha}$ (EDT)	$\bar{\alpha}$ (T ₂₀)
80	12.00	12.30	3.88	0.01	3.61	0.01
100	10.50	10.87	4.26	0.02	4.07	0.02
125	8.67	9.21	4.85	0.02	4.78	0.02
160	7.48	8.33	5.61	0.02	5.25	0.02
200	6.48	7.37	6.29	0.02	5.88	0.02
250	6.35	6.79	6.37	0.02	6.30	0.02
315	6.51	6.73	6.40	0.02	6.23	0.02
400	6.21	6.49	6.56	0.02	6.30	0.02
500	5.36	5.61	7.35	0.03	7.16	0.03
630	4.78	5.32	7.72	0.03	7.37	0.03
800	4.44	4.76	8.42	0.03	8.09	0.03
1000	4.26	4.47	8.66	0.03	8.45	0.03
1250	4.25	4.29	8.73	0.03	8.61	0.03
1600	3.86	3.90	9.40	0.03	9.28	0.03
2000	3.64	3.60	9.86	0.04	9.79	0.04
2500	3.21	3.21	10.66	0.04	10.67	0.04
3150	2.97	2.89	11.26	0.04	11.21	0.04
4000	2.55	2.50	12.37	0.05	12.04	0.04
5000	1.95	1.94	15.58	0.06	14.91	0.06
6300	1.58	1.58	17.36	0.06	16.30	0.06
8000	1.25	1.26	19.14	0.07	17.24	0.06

REPORT DOCUMENTATION PAGE

*Form Approved
OMB No. 0704-0188*

The public reporting burden for this collection of information is estimated to average 1 hour per response, including the time for reviewing instructions, searching existing data sources, gathering and maintaining the data needed, and completing and reviewing the collection of information. Send comments regarding this burden estimate or any other aspect of this collection of information, including suggestions for reducing this burden, to Department of Defense, Washington Headquarters Services, Directorate for Information Operations and Reports (0704-0188), 1215 Jefferson Davis Highway, Suite 1204, Arlington, VA 22202-4302. Respondents should be aware that notwithstanding any other provision of law, no person shall be subject to any penalty for failing to comply with a collection of information if it does not display a currently valid OMB control number.
PLEASE DO NOT RETURN YOUR FORM TO THE ABOVE ADDRESS.

1. REPORT DATE (DD-MM-YYYY) 01-02-2013		2. REPORT TYPE Contractor Report		3. DATES COVERED (From - To)	
4. TITLE AND SUBTITLE Characterization of the Reverberation Chamber at the NASA Langley Structural Acoustics Loads and Transmission (SALT) Facility				5a. CONTRACT NUMBER NNL12AA09C	
				5b. GRANT NUMBER	
				5c. PROGRAM ELEMENT NUMBER	
				5d. PROJECT NUMBER	
6. AUTHOR(S) Grosveld, Ferdinand W.				5e. TASK NUMBER	
				5f. WORK UNIT NUMBER 380046.02.07.04.01.05	
				8. PERFORMING ORGANIZATION REPORT NUMBER	
7. PERFORMING ORGANIZATION NAME(S) AND ADDRESS(ES) NASA Langley Research Center Hampton, Virginia 23681				10. SPONSOR/MONITOR'S ACRONYM(S) NASA	
9. SPONSORING/MONITORING AGENCY NAME(S) AND ADDRESS(ES) National Aeronautics and Space Administration Washington, DC 20546-0001				11. SPONSOR/MONITOR'S REPORT NUMBER(S) NASA/CR-2013-217968	
12. DISTRIBUTION/AVAILABILITY STATEMENT Unclassified - Unlimited Subject Category 71 Availability: NASA CASI (443) 757-5802					
13. SUPPLEMENTARY NOTES This report was prepared by Northrop Grumman under NASA contract NNL12AA09C with Analytical Mechanics Associates, Inc., Hampton, VA Langley Technical Monitor: Randolph H. Cabell					
14. ABSTRACT In 2011 the noise generating capabilities in the reverberation chamber of the Structural Acoustic Loads and Transmission (SALT) facility at NASA Langley Research Center were enhanced with two fiberglass reinforced polyester resin exponential horns, each coupled to Wyle Acoustic Source WAS-3000 airstream modulators. This report describes the characterization of the reverberation chamber in terms of the background noise, diffusivity, sound pressure levels, the reverberation times and the related overall acoustic absorption in the empty chamber and with the acoustic horn(s) installed. The frequency range of interest includes the 80 Hz to 8000 Hz one-third octave bands. Reverberation time and sound pressure level measurements were conducted and standard deviations from the mean were computed. It was concluded that a diffuse field could be produced above the Schröder frequency in the 400 Hz one-third octave band and higher for all applications. This frequency could be lowered by installing panel diffusers or moving vanes to improve the acoustic modal overlap in the chamber. In the 80 Hz to 400 Hz one-third octave bands a successful measurement will be dependent on the type of measurement, the test configuration, the source and microphone locations and the desired accuracy. It is recommended that qualification measurements endorsed in the International Standards be conducted for each particular application.					
15. SUBJECT TERMS absorption; acoustics; diffuse field; diffusivity; horn; pneumatic; reverberation chamber; reverberation time; room modes; standard deviation					
16. SECURITY CLASSIFICATION OF:			17. LIMITATION OF ABSTRACT	18. NUMBER OF PAGES	19a. NAME OF RESPONSIBLE PERSON
a. REPORT	b. ABSTRACT	c. THIS PAGE			STI Help Desk (email: help@sti.nasa.gov)
U	U	U	UU	48	19b. TELEPHONE NUMBER (Include area code) (443) 757-5802