

NASA Standard Initiator Susceptibility to UHF and S-Band Radio Frequency Power and Lightning Strikes

Abstract—The NASA Standard Initiator (NSI) is an important piece of pyrotechnic equipment used in many space applications. This paper outlines the results of a series of tests done at UHF and S-Band frequencies to determine NSI susceptibility to Radio Frequency (RF) power. The results show significant susceptibility to pulsed RF power in the S-Band region. Additional testing with lightning pulses injected into the firing line harness, modelling the indirect effects of a lightning strike to a spacecraft, showed no vulnerability.

I. INTRODUCTION

NASA Standard Initiators (NSIs) are standard equipment used in many space applications. They are bridgewire activated Electro Explosive Devices (EEDs) that are designed to fire when greater than 3.5 W of dc power is delivered to the bridgewire in the pin-to-pin mode. The bridgewire, with a resistance of $1.05 \pm 0.1 \Omega$, heats up and causes the initiating explosive mixture, zirconium potassium perchlorate (ZPP), to ignite. The NSI response to an applied dc current stimulus is specified and tightly controlled. NSI behavior over a wide range of temperatures and physical impact levels is also well known. Additional details regarding NSI construction and performance are available in [1]. However, its response to Radio Frequency (RF) energy has only been characterized over a small number of discrete frequencies. Previous testing conducted in 1966 and 1983 by the Franklin Applied Physics Institute ([2] – [5]) examined responses to 11 discrete frequencies ranging from 10 MHz to 33.2 GHz.

In an effort to expand the knowledge base in this area and prevent misfires, the tests described herein investigated the effect of RF power on NSIs at six frequencies specific to NASA's Multi Purpose Crew Vehicle (MPCV) program, listed in Table I.

TABLE I
FREQUENCIES CHOSEN FOR RF TESTING

| Frequency (MHz) | Pulse Width | PRF |
|-----------------|-------------|---------|
| 414.2 | CW | -- |
| 2265 | 10 μ s | 1000 Hz |
| 2287.5 | 10 μ s | 1000 Hz |
| 2380 | 10 μ s | 1000 Hz |
| 2470 | CW | -- |
| 2712 | CW | -- |

Table I described the pulses used, either continuous wave (CW) or brief pulses with a certain pulse repetition frequency (PRF). The amount of RF power required to cause an NSI to initiate was measured. In all cases the RF power was injected directly into the NSI in the pin-to-case mode representing a

worst case scenario of power transfer. The pin-to-case mode is seen as the most likely path for the external electromagnetic environment to cause inadvertent initiation of the NSI through common mode coupling on a firing line. The NSIs fired at relatively low power levels at all six test frequencies.

Testing was also performed to determine the effect of conducted current transients resulting from lightning strikes to the vehicle. Lightning pulses based on Waveform 4 of SAE ARP 5412 [6] were injected onto the shielding of a flight-like firing line cable harness with multiple current levels. In no case was an NSI fired commensurate with any current injection. Subsequent testing revealed no indication of significant heating of the bridgewire from these current transients.

II. RF EXPOSURE TEST SET-UP

Fig. 1 illustrates the equipment involved in conducting the RF exposure tests. A signal generator created the necessary CW or pulsed waveforms, and an amplifier with the appropriate frequency and power ranges delivered the necessary power. The power meter monitoring the forward and reverse power from the bi-directional coupler measured the amount of power being reflected due to the impedance mismatch with the load. The tuner, a double stub for UHF and a triple stub for S-Band, allowed some control of impedance mismatches.

Three adapters were constructed to interface the NSI to the 50 Ω coaxial test equipment. The UHF adapter shown in Fig. 2 was constructed from a female N connector and the center portion of a 38999 NSI connector. The center conductor of the N connector was soldered directly to the two pins of the NSI connector. The assembly was then secured with copper tape and zip ties. This was used for all measurements at 414.2 MHz.

Two S-Band adapters were built up according to the drawing shown in Fig. 3. An outer housing of copper or brass was bored out. On the coaxial side, the opening was tapped to accommodate a female SMA connector that was modified to allow for dielectric-to-dielectric contact. A Teflon insert incorporating a wire transition from a single to a dual pin configuration was developed to fill the body of the adapter. On the left side a pin that mated to the center conductor of the SMA connector was secured using conductive epoxy. Then two wires were tapered from that point to the 20 gauge sockets that mated with the NSI pins. The taper created a better impedance match than a stepped transition.

The first adapter had a body of copper and used 20 AWG wire for the tapered wires. It was used for tests at all S-Band frequencies. Over the course of testing this adapter became

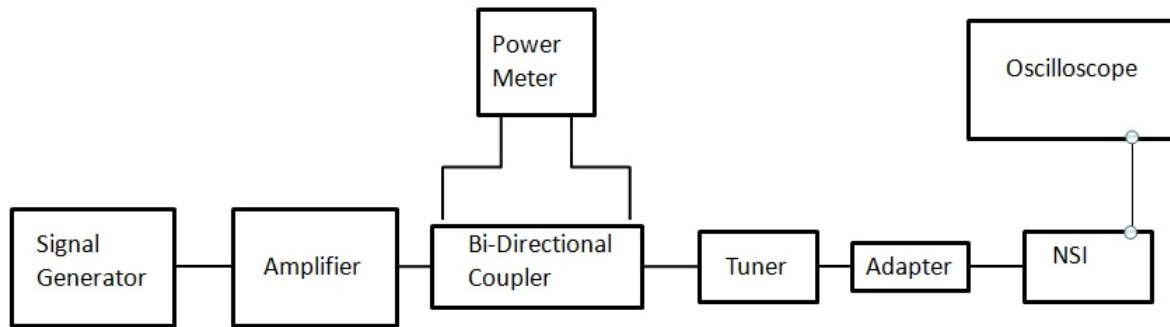

Fig. 1. RF Testing Block Diagram



Fig. 2. UHF Adapter

noticeably degraded. When used for CW tests in which the NSI failed to fire, temperatures on the surface of the adapter were measured to be over 150°F using a hand-held infrared thermometer. Burnishing of the surfaces was noted, the Teflon insert shrank and became loose in the body, and the conductive epoxy securing the SMA pin loosened as well. For the final five units tested at 2.47 GHz, a second adapter with a brass body was used. The only differences between the two are the body materials and the 16 AWG used in the brass adapter for its tapered section. A fully assembled adapter can be seen in Fig. 4.

III. PRE-AND POST-RF EXPOSURE MEASUREMENTS

A. Bridgewire Resistance

83 NSIs were measured with an Initiator Resistance Measurement Unit (IRMU) before and after the test exposures. Before testing all NSIs measured intact bridgewires with resistances within the NSI Spec of $1.05 \pm 0.1 \Omega$. The average value was 1.05Ω , with a range of 0.99 to 1.11 Ω . After testing, all NSIs that were fired were found to have open bridgewires, as expected. Of the non-fired units, none had a change in bridgewire resistance of more than 0.01 Ω , within the measurement error of the device. The post-test average was 1.06 Ω , with a range of 0.99 to 1.11 Ω .

B. Pin-to-Case Capacitance

Before and after each test exposure, 71 of the NSIs were connected to an LCR meter to measure their pin-to-case capacitance. 12 NSIs could not be measured due to issues with the adapter. Before testing the average capacitance of an NSI was 6.4 pF, with a range of 3.6 to 13.7 pF. Of the 40 units that did not fire, the post-test measurement averaged 6.2 pF with a range of 4.7 to 9.8 pF. The average change was 0.6 pF, well within the measurement error of ± 1 pF. For fired units, the post-test measurements showed an average capacitance of 8.7 pF with a range of 4.3 to 21.3 pF and an average change of 3.5 pF. This change of up to 50% is significant and understandable given the changed nature of the material inside the NSI after firing. This indicates that inert NSIs, which are often created from expended units, are not good stand-ins for live NSIs in regards to RF testing.

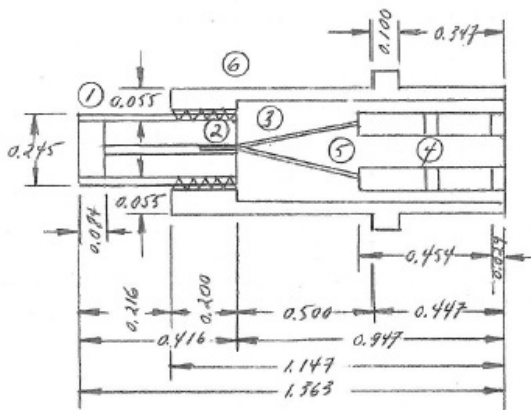

Fig. 3. Drawing for the S-Band adapter



Fig. 4. Fully Assembled Copper S-Band Adapter

C. Impedance

The NSIs could not be connected directly to the Network Analyzer and so were measured with an adapter in place. In each case, the impedance of the adapter was measured with both an open and a short load. These two values facilitate calculation of the characteristic impedance of the adapter using:

$$Z_c = \sqrt{Z_{open} Z_{short}} \quad (1)$$

Calculating the characteristic impedance allowed each measured impedance of the NSI plus adapter to be corrected to isolate the NSI impedance. Table II shows the corrected impedances for the NSIs at each frequency. Both pre- and post-exposure measurements of fired and unfired units are shown.

TABLE II
NSI CORRECTED IMPEDANCE MEASUREMENTS

| Frequency (MHz) | Pre-Exposure (R + jX Ω) | Post-Exposure (Unfired) (R + jX Ω) | Post-Exposure (Fired) (R + jX Ω) |
|-----------------|-------------------------|------------------------------------|----------------------------------|
| 414.2 | 235.3 - j236.3 | 325.6 - j199.1 | 395.1 - j85.7 |
| 2265.0 | 78.6 - j3.1 | 32.8 - j34.8 | 44.1 + j35.8 |
| 2287.5 | 39.2 - j14.5 | 29.4 - j32.5 | 9.0 + j28.5 |
| 2380 | 12.1 + j9.2 | 5.7 + j8.0 | 10.4 + j12.5 |
| 2470 | 4.6 + j34.0 | 22.8 + j37.7 | 3.3 + j34.8 |
| 2712 | 53.9 - j17.1 | 18.3 - j10.2 | 26.3 - j15.2 |

The Smith charts shown in Figs. 5 and 6 show a more detailed picture of the measured NSI impedances. They reinforce the impression that the NSI has a potential resonance in S-Band, close to 2.2 or 2.3 GHz, where in crossing from being inductive to being capacitive, they become purely resistive. The Smith chart of the fired units is sufficiently different from the pre-exposure impedances that it again indicates that inert NSIs would make poor stand-ins for live NSIs in RF testing.

IV. RF EXPOSURE

At each frequency, between 10 and 16 individual NSIs were exposed to different power levels. Test levels were determined using the Neyer software, described in [7]. Before testing began, guesses as to the range of the expected mean and standard deviations of the firing power levels were input into the software. These guesses were arrived at using knowledge from the previous Franklin tests. For each individual exposure a power level was specified by the software. This level would either increase or decrease from the previous level based on whether or not the previous test caused the NSI to fire. After testing was complete, the Neyer software calculated predicted mean firing power, standard deviations, and 0.001% ('no-fire') and 0.999% ('all-fire') limits for the NSIs.

During testing, "Power Delivered" was defined as the forward power meter minus the reflected power also measured by the power meter. However, it should be understood that

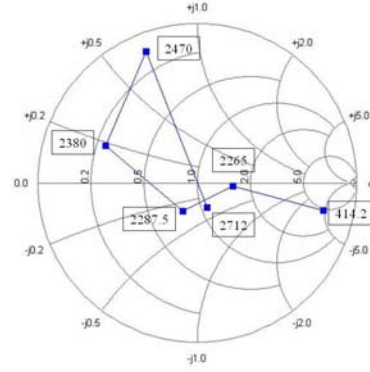

Fig. 5. Normalized impedances for pre-exposure NSIs

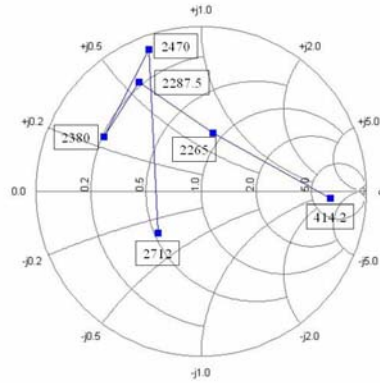

Fig. 6. Normalized impedances of fired units, post-exposure

this number does not translate directly to the power delivered to the NSI.

It was observed that a significant fraction of the power was being lost to heating of the various elements of the test equipment, specifically the NSI body, the NSI adapter, and the tuner, and that some of the power was also radiating away. After the testing was completed, the OpSens bridgewire temperature monitoring system was used to equate the "Power Delivered" with actual current flow and heating of the NSI bridgewire. The OpSens system uses an NSI stand-in with a fiberoptic thermocouple in direct contact with the bridgewire. The fiberoptic system is immune to EMI, allowing for accurate measurements in harsh RF environments. The OpSens machine is calibrated specifically to equate the temperature registered by the thermocouple probe to the power appearing on the NSI bridgewire.

The efficiency factors varied dramatically over the course of the tests, presumably because the NSI body acted as a heat sink, but they allowed the setting of limits on the range of firing energies involved in the testing. In all cases, the power transfer is relatively inefficient, especially for the pulsed waveforms. Table III shows the range of power transfer efficiency measured at each frequency.

Table IV shows the actual mean firing power, the mean firing power calculated by the Neyer software, and the no-fire

and all-fire limits calculated by the software package. The Neyer software consistently over-estimated the firing power, since it assumed that a ‘fire’ meant that the NSI had reached its prescribed test level, then fired. In truth, the NSI usually fired at a lower power level while the power was being increased to reach the test level. Thus the difference between the Neyer mean levels and the ‘Actual’ mean levels in Table IV. The Neyer progression could not be followed in the 2712 MHz test due to problems reaching the high power levels required. Only the actual mean firing power is provided for that case. The No-Fire level for the 414.2 MHz case was calculated to be negative by the Neyer software due to the large standard deviation of the data. Presumably testing additional units at that frequency would produce more accurate statistics.

TABLE III
POWER TRANSFER EFFICIENCY TO THE BRIDGEWIRE FROM OPSENS MEASUREMENTS (%)

| Freq (Mhz) | Pulse Type | Eff (min) | Eff (max) |
|------------|------------|-----------|-----------|
| 414.2 | CW | 1.6 | 20.5 |
| 2265 | Pulsed | 0.5 | 14.0 |
| 2287.5 | Pulsed | 0.4 | 2.9 |
| 2380 | Pulsed | 0.6 | 1.9 |
| 2470 | CW | 3.1 | 31.9 |
| 2712 | CW | 7.4 | 28.4 |

TABLE IV
SUMMARY OF UNADJUSTED FIRING POWER (W)

| Freq (MHz) | Actual μ | Neyer μ | Neyer σ | Neyer No-Fire | Neyer All-Fire |
|------------|--------------|-------------|----------------|---------------|----------------|
| 414.2 | 4.15 | 4.9 | 2.28 | -2.12 | 12.0 |
| 2265 | 0.86 | 0.84 | 0.102 | 0.525 | 1.15 |
| 2287.5 | 0.597 | 0.563 | 0.097 | 0.263 | 0.862 |
| 2380 | 1.04 | 0.936 | 0.063 | 0.742 | 1.13 |
| 2470 | 12.73 | 13.81 | 3.29 | 3.62 | 23.99 |
| 2712 | 36.55 | -- | -- | -- | -- |

Table V provides the firing power ranges adjusted per the OpSens measurements. Using the Neyer and Actual limits to bound the firing power, as adjusted for the efficiency factor in delivering power to the bridgewire of the NSI, the ‘Median’ number in Table V is simply the mid-point between the extremes of that range. These numbers reflect the actual power arriving at the bridgewire of the NSI due to pin-to-case power coupling.

TABLE V
SUMMARY OF ADJUSTED FIRING POWER (W) RANGES

| Freq (MHz) | Actual Min | Actual Max | Neyer Min | Neyer Max | Median |
|------------|------------|------------|-----------|-----------|--------|
| 414.2 | 0.066 | 0.85 | 0.078 | 1.0 | 0.53 |
| 2265 | 0.0043 | 0.12 | 0.0042 | 0.12 | 0.062 |
| 2287.5 | 0.0024 | 0.017 | 0.0023 | 0.016 | 0.0096 |
| 2380 | 0.0062 | 0.02 | 0.0056 | 0.018 | 0.013 |
| 2470 | 0.39 | 4.1 | 0.43 | 4.4 | 2.4 |
| 2712 | 2.7 | 10.4 | -- | -- | 6.5 |

After all NSIs were returned to the Energy Systems Test Area at NASA Johnson Space Center, all unfired units were

fired using a standard pin-to-pin firing system. All units fired normally with no dudding observed.

V. LIGHTNING EXPOSURE

A. Test Set-Up

In this test, an NSI was interfaced with an MPCV flight-like connector and cable harness. The firing line was terminated by a 1000 Ω resistor in a Pyro Event Controller (PEC) card. Fig. 7 shows a block diagram of the test set-up.

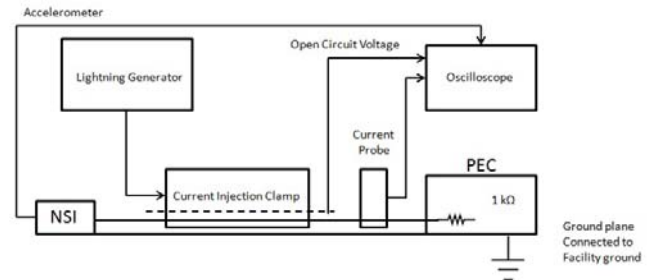

Fig. 7. Block diagram of lightning test set-up

The box containing the PEC was wrapped in aluminium, taped with copper tape, and bonded to the aluminium ground plane. The 1-cc closed bomb containing the NSI was bonded to the same plane. The closed bomb is a steel enclosure meant to contain the result of any NSI firing. The shield on the firing line was bonded to the PEC enclosure. Current injection clamps surrounded the firing line, driven by the lightning waveform generator. An oscilloscope monitored the voltage induced by the current clamps and the current flowing on the cable shield. An accelerometer was mounted to the 1-cc closed bomb which would indicate if the NSI fired. Resistances between bonded elements were measured and in all cases were less than 0.5 Ω . The lightning generator was set to produce an RTCA/DO-160D [8] current Waveform 4, shown in Fig. 9, a double exponential waveform with a 6.4 μ s rise time and a 69 μ s decay to 50%.

B. Test Results

All testing resulted in no-fires from the NSIs. The test exposure levels and the results of each exposure are shown in Table VI.

TABLE VI
NSI LIGHTNING EXPOSURE LEVELS AND RESULTS

| Test Level | Result |
|------------------------|---------|
| 100 A, Single Pulse | No Fire |
| 120 A, Single Pulse | No Fire |
| 130 A, Single Pulse | No Fire |
| 160 A, Single Pulse | No Fire |
| 240 A, Single Pulse | No Fire |
| 260 A, Multiple Burst | No Fire |
| 250 A, Multiple Stroke | No Fire |
| 280 A, Single Pulse | No Fire |

The trace of the lightning generator, shown in Fig. 8, compares well with the prescribed shape of Lightning Waveform 4 from [6], shown in Fig. 9. In the multiple burst

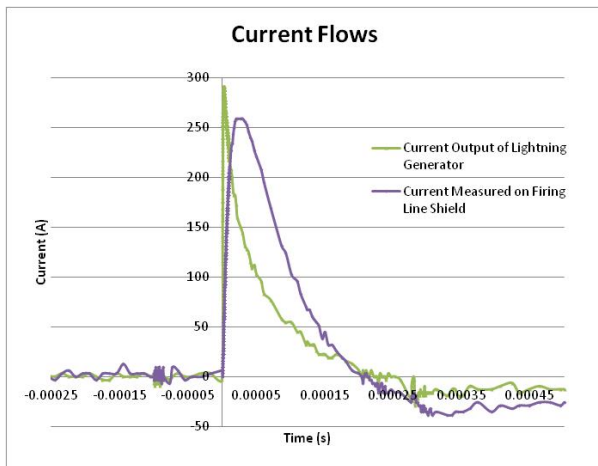

Fig. 8. Representative oscilloscope trace showing the lightning generator output (as measured by the open circuit voltage) and current on the firing line shield

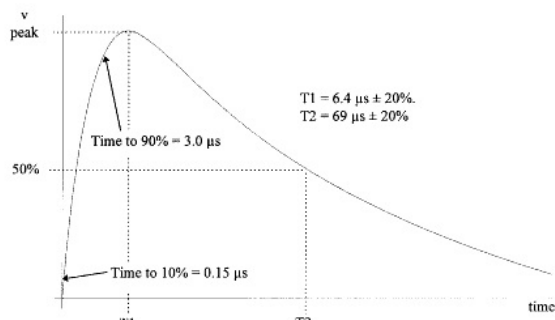

Fig. 9. Lightning waveform 4

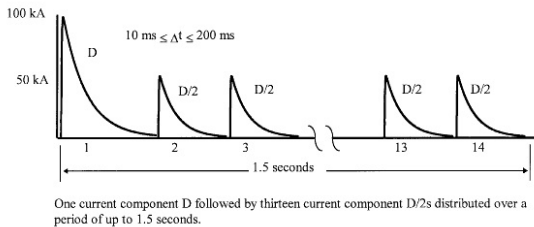

Fig. 10. Lightning waveform 4, multiple burst pattern

test, a 260 A stroke was followed by 13 strokes of 180 A magnitude in quick succession. Fig. 10 from [6] illustrates this pattern. In the multiple stroke test, a string of 10 strokes of 250 A magnitude was generated.

As in the RF tests, each NSI was measured for bridgewire resistance and pin-to-case capacitance both before and after exposure to the test stimulus. No changes to the bridgewire resistance were measured. The capacitance measurements showed a consistent increase of 1.0 to 1.2 pF after exposure. This is greater than the 0.8 standard deviation of the samples overall.

After the NSI tests were completed successfully, an attempt was made to directly measure the currents induced in the NSI bridgewire as a result of the lightning currents on the shield. To this end, the OpSens sensor was installed in place of the NSI. The OpSens system has a maximum sampling rate of 1000 Hz. Even at the highest test levels produced by the

lightning generator (Multiple Burst waveform at 250 A), there was no observable heating (and thus no significant current flow) measured on the bridgewire. The effect of an individual lightning transient may be over too quickly (decaying to 50% in 69 μ s) to be sensed by the OpSens system, which takes a sample every 1000 μ s.

VI. CONCLUSION

NSIs as measured in this test series did not exhibit any susceptibility to standard Waveform 4 excitation currents inductively coupled onto the shield of the firing cable up to a maximum amplitude of 280 A in single stroke, multi-stroke, and multi-burst formats. In post-test measurements, no heating or significant current flow was observed directly on a mock EED bridgewire under the same conditions. Additionally, all NSIs exposed to the Waveform 4 excitations fired normally after the test. These results give some confidence to the perception that NSIs, when properly installed in a shielded firing system, with appropriate bonding and grounding precautions, will not be affected by indirect lightning events.

In testing the RF susceptibility of NSIs, NSIs exhibited a marked sensitivity to S-Band power, firing with as little as 0.01 W on the bridgewire. In all cases the NSI is more sensitive to pulsed waveforms than to CW sources. The impedance measurements taken will allow for a more comprehensive model of the NSI circuit characteristics to be developed at these frequencies. The initial graphs, such as the Smith charts in Figs. 5 and 6, suggest that the NSIs approach a resonance, where the load looks purely resistive, between 2.2 and 2.8 GHz. While the NSIs did not appear particularly sensitive to CW power at 2.712 GHz, in the original Franklin Institute tests NSIs were fired at powers as low as 0.08 W at 2.7 GHz in the pulsed pin-to-case mode.

Pre- and post-exposure measurements registered almost no change to the circuit characteristics of unfired NSIs due to lightning or RF exposure. However, the difference in the capacitance and impedance of fired units is significant. This indicates that inert NSIs are likely unsuitable for tests that require accurate mimicking of RF characteristics. Throughout these tests, the repeated heating and cooling of the NSI-coaxial adapters, already fragile to begin with, represents a significant and not fully characterized source of error. However, ranges within which the NSI is expected to respond to RF power have been bounded, and these ranges are lower than previously suspected.

ACKNOWLEDGMENT

The authors would like to thank Dr. James Stuart of the Franklin Applied Physics Institute and Mary Harris of NASA Johnson Space Center for their help and advice throughout the testing process. Todd Hinkel and the NASA JSC EP3 group and Maureen Dutton and the NASA JSC EP6 group were invaluable assisting in the procurement, handling, and training processes.

REFERENCES

- [1] *NASA Standard Initiator User's Guide*, JSC-28596A, 2000.
- [2] P. Mohrbach, R. F. Wood, and V. W. Goldie, "Special Radio Frequency Tests on Apollo Standard Initiator," Franklin Applied Physics Institute, Oaks, PA, F-B2303-4, 1966.
- [3] P. F. Mohrbach, and R. F. Wood, "Sensitivity of the Hi-Shear Version of the Apollo Standard Initiator to 9000 Megahertz Pulsed Energy," Franklin Applied Physics Institute, Oaks, PA, F-B2303-5, 1966.
- [4] P. F. Mohrbach and R. R. Raksnis, "RF Evaluation of the Single Bridgewire Apollo Standard Initiator," Franklin Applied Physics Institute, Oaks, PA, F-B2303-9, 1967.
- [5] J. G. Stuart and R. H. Thompson, "Microwave Tests on NASA Standard Initiators at 9 GHz, 9.9 GHz, 33 GHz, and in Ku-Band," Franklin Research Center, Oaks, PA, F-C5867-2, 1983.
- [6] *Aircraft Lightning Environment and Related Test Waveform*, SAE ARP 5412, 1999.
- [7] B. T. Neyer, "A D-Optimally-Based Sensitivity Test," *Technometrics*, vol. 36, no. 1, pp. 61-70, Feb 1994.
- [8] *Environmental Conditions and Test Procedures for Airborne Equipment*, RTCA/DO-160D, 1997.