

National Aeronautics and  
Space Administration

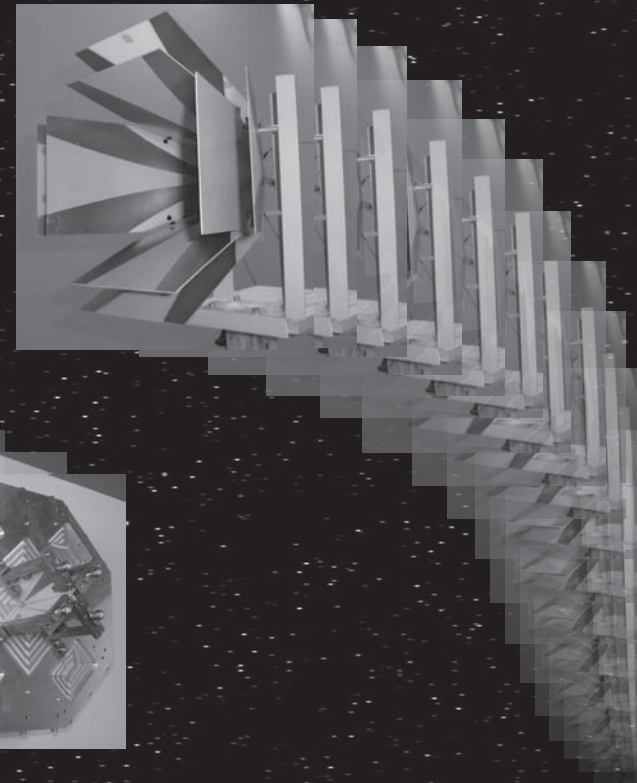

International VLBI Service for  
Geodesy and Astrometry

# Annual Report 2011

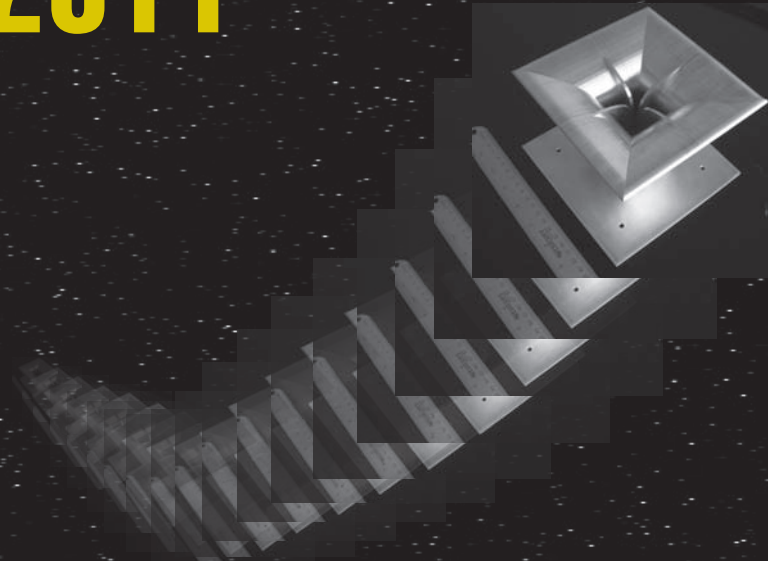
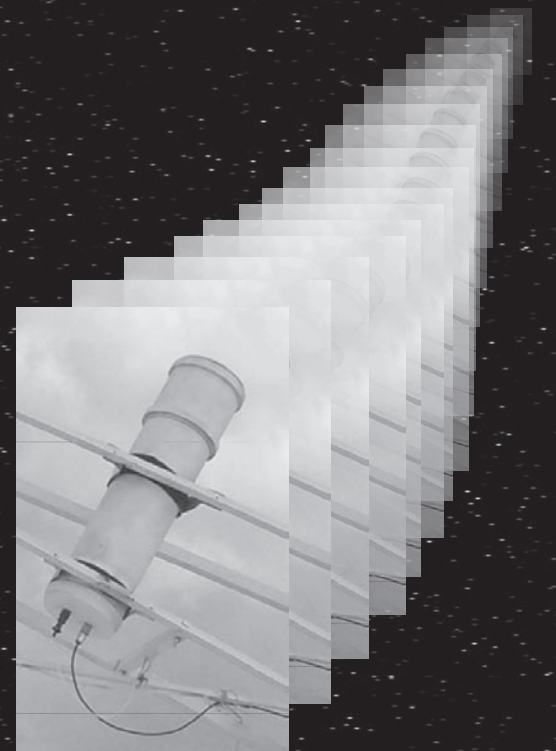

Edited by  
K.D. Baver and D. Behrend

IVS Coordinating Center  
June 2012

## The NASA STI Program Office ... in Profile

Since its founding, NASA has been dedicated to the advancement of aeronautics and space science. The NASA Scientific and Technical Information (STI) Program Office plays a key part in helping NASA maintain this important role.

The NASA STI Program Office is operated by Langley Research Center, the lead center for NASA's scientific and technical information. The NASA STI Program Office provides access to the NASA STI Database, the largest collection of aeronautical and space science STI in the world. The Program Office is also NASA's institutional mechanism for disseminating the results of its research and development activities. These results are published by NASA in the NASA STI Report Series, which includes the following report types:

- **TECHNICAL PUBLICATION.** Reports of completed research or a major significant phase of research that present the results of NASA programs and include extensive data or theoretical analysis. Includes compilations of significant scientific and technical data and information deemed to be of continuing reference value. NASA's counterpart of peer-reviewed formal professional papers but has less stringent limitations on manuscript length and extent of graphic presentations.
- **TECHNICAL MEMORANDUM.** Scientific and technical findings that are preliminary or of specialized interest, e.g., quick release reports, working papers, and bibliographies that contain minimal annotation. Does not contain extensive analysis.
- **CONTRACTOR REPORT.** Scientific and technical findings by NASA-sponsored contractors and grantees.

- **CONFERENCE PUBLICATION.** Collected papers from scientific and technical conferences, symposia, seminars, or other meetings sponsored or cosponsored by NASA.
- **SPECIAL PUBLICATION.** Scientific, technical, or historical information from NASA programs, projects, and mission, often concerned with subjects having substantial public interest.
- **TECHNICAL TRANSLATION.** English-language translations of foreign scientific and technical material pertinent to NASA's mission.

Specialized services that complement the STI Program Office's diverse offerings include creating custom thesauri, building customized databases, organizing and publishing research results . . . even providing videos.

For more information about the NASA STI Program Office, see the following:

- Access the NASA STI Program Home Page at <http://www.sti.nasa.gov/STI-homepage.html>
- E-mail your question via the Internet to [help@sti.nasa.gov](mailto:help@sti.nasa.gov)
- Fax your question to the NASA Access Help Desk at (443) 757-5803
- Telephone the NASA Access Help Desk at (443) 757-5802
- Write to:  
NASA Access Help Desk  
NASA Center for AeroSpace Information  
7115 Standard Drive  
Hanover, MD 21076-1320

Front cover:

*The development and use of new technology continues to advance within IVS. The front cover shows four selected examples of design and development work described in this year's Annual Report (in clockwise direction): [top right] broadband phase calibration system (breadboard model) at Svetloe Observatory; [bottom right] experimental wide-band feed elements for Arrayed Travel Wave Antenna studies developed at NICT and cooperating Japanese institutions; [bottom left] prototype of a Balun-fed Eleven feed with a linear taper developed at Chalmers University; and [top left] QRFH broadband feed at the Westford 18-m antenna. More details about the displayed technology are available in the Technology Development (TD) Center reports of IAA (p. 287ff), NICT (p. 291ff), Onsala Space Observatory (p. 295ff) and Haystack Observatory (p. 283ff), respectively. Photos are courtesy of these TD Centers and their collaborators at other institutions.*

NASA/TP—201G-211

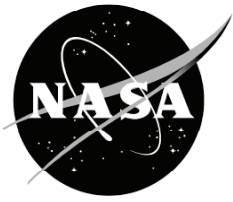

# International VLBI Service for Geodesy and Astrometry 2011 Annual Report

*Søren Øzcelik (ed.)*  
*NVI, Inc., Greenbelt, Maryland*

*Dirk Behrend (ed.)*  
*NVI, Inc., Greenbelt, Maryland*

National Aeronautics and  
Space Administration

*Goddard Space Flight Center*  
*Greenbelt, MD 20771-0001*

---

**June 2012**

---

Available from:

NASA Center for Aerospace Information  
7115 Standard Drive  
Hanover, MD 21076-1320  
Price Code: A17

National Technical Information Service  
5301 Shawnee Road  
Alexandria, VA 22312  
Price Code: A10

## Preface

This volume of reports is the 2011 Annual Report of the International VLBI Service for Geodesy and Astrometry (IVS). The individual reports were contributed by VLBI groups in the international geodetic and astrometric community who constitute the permanent components of IVS.

The IVS 2011 Annual Report documents the work of the IVS components for the calendar year 2011, our thirteenth year of existence. The reports describe changes, activities, and progress of the IVS. Many thanks to all IVS components who contributed to this Annual Report.

The contents of this Annual Report also appear on the IVS Web site at

<http://ivscc.gsfc.nasa.gov/publications/ar2011>

This book and the Web site are organized as follows:

- The first section contains general information about IVS, a map showing the location of the components, information about the Directing Board members, and the annual report of the IVS Chair.
- The second section holds a special report about the IVS Retreat at Hohe Wand, Austria including a reproduction of the retreat's final declaration. A major focus of the retreat was a review and update of the IVS Terms of Reference (ToR). The updated ToR can be found in the last section (see below).
- The next seven sections hold the reports from the Coordinators and the reports from the IVS Permanent Components: Network Stations, Operation Centers, Correlators, Data Centers, Analysis Centers, and Technology Development Centers.
- The next section contains a compilation of publications in the field of geodetic and astrometric VLBI during 2011.
- The last section includes reference information about IVS: the Terms of Reference, the lists of Member and Affiliated organizations, the IVS Associate Member list, a complete list of IVS components, the list of institutions that contributed to this report, and a list of acronyms.



# Table of Contents

Preface .....	iii
<b>About IVS .....</b>	<b>1</b>
IVS Organization .....	2
IVS Component Map .....	4
IVS Directing Board .....	6
IVS Chair's Report .....	8
<b>Special Reports .....</b>	<b>11</b>
Hohe Wand Declaration .....	13
<b>IVS Coordination .....</b>	<b>15</b>
Coordinating Center Report .....	17
Analysis Coordinator Report .....	21
Network Coordinator Report .....	24
IVS Technology Coordinator Report .....	28
<b>Network Stations .....</b>	<b>33</b>
Badary Radio Astronomical Observatory .....	35
Fortaleza Station Report for 2011 .....	39
Goddard Geophysical and Astronomical Observatory .....	42
Hartebeesthoek Radio Astronomy Observatory (HartRAO) .....	46
AuScope VLBI Project and Hobart 26-m Antenna .....	50
Kashima 34-m Radio Telescope .....	54
Kashima and Koganei 11-m VLBI Stations .....	58
Kokee Park Geophysical Observatory .....	62
Matera CGS VLBI Station .....	66
The Medicina Station Status Report .....	70
VERA Geodetic Activities .....	72
Noto Station Status Report .....	76
Ny-Ålesund 20-meter Antenna .....	80
German Antarctic Receiving Station (GARS) O'Higgins .....	84
Onsala Space Observatory – IVS Network Station .....	88
Parkes 2011 IVS Report .....	92
Sheshan VLBI Station Report for 2011 .....	93
Geodetic and Astrophysical Study at the Simeiz VLBI Station .....	95
Svetloe Radio Astronomical Observatory .....	99
JARE Syowa Station 11-m Antenna, Antarctica .....	103
Status and Developments at TIGO Concepción .....	107
Tsukuba 32-m VLBI Station .....	111
Nanshan VLBI Station Report for 2011 .....	115
Warkworth 12-m VLBI Station: WARK12M .....	119
Westford Antenna .....	123
Geodetic Observatory Wettzell - 20-m Radio Telescope and Twin Telescope .....	127
Instituto Geográfico Nacional of Spain .....	131
Zelenchukskaya Radio Astronomical Observatory .....	135

<b>Operation Centers</b> .....	<b>139</b>
The Bonn Geodetic VLBI Operation Center .....	141
CORE Operation Center Report .....	143
NEOS Operation Center .....	147
<b>Correlators</b> .....	<b>149</b>
The Bonn Astro/Geo Correlator .....	151
Haystack Observatory VLBI Correlator .....	155
IAA Correlator Center .....	159
VLBI Correlators in Kashima .....	161
Tsukuba VLBI Correlator .....	165
Washington Correlator .....	169
<b>Data Centers</b> .....	<b>173</b>
BKG Data Center .....	175
CDDIS Data Center Summary for the IVS 2011 Annual Report .....	177
Italy INAF Data Center Report .....	180
Data Center at NICT .....	181
Paris Observatory (OPAR) Data Center .....	185
<b>Analysis Centers</b> .....	<b>189</b>
Analysis Center of Saint Petersburg University .....	191
Geoscience Australia Analysis Center .....	193
Report for 2011 from the Bordeaux IVS Analysis Center .....	197
BKG/DGFI Combination Center Annual Report 2011 .....	201
Matera CGS VLBI Analysis Center .....	204
DGFI Analysis Center Annual Report 2011 .....	206
FFI Analysis Center .....	208
The BKG/IGGB VLBI Analysis Center .....	209
GSFC VLBI Analysis Center .....	213
IAA VLBI Analysis Center Report 2011 .....	217
Vienna IGG Special Analysis Center Annual Report 2011 .....	220
Italy INAF Analysis Center Report .....	224
JPL VLBI Analysis Center Report for 2011 .....	226
KASI Combination Center Report .....	230
KTU-GEOD IVS Analysis Center Annual Report 2011 .....	234
IVS Analysis Center at Main Astronomical Observatory of National Academy of Sciences of Ukraine	236
Analysis Center at National Institute of Information and Communications Technology .....	238
NMA Analysis Center .....	242
Paris Observatory Analysis Center OPAR: Report on Activities, January - December 2011 .....	245
Onsala Space Observatory – IVS Analysis Center .....	249
PMD Analysis Center Report for 2011 .....	252
Pulkovo IVS Analysis Center (PUL) 2011 Annual Report .....	256
SAI VLBI Analysis Center Report 2011 .....	259
SHAO Analysis Center 2011 Annual Report .....	261
Tsukuba VLBI Analysis Center .....	264
U.S. Naval Observatory VLBI Analysis Center .....	268
USNO Analysis Center for Source Structure Report .....	272



<b>Technology Development Centers</b> .....	<b>275</b>
Canadian VLBI Technology Development Center .....	277
FFI Technology Development Center - Software Development .....	278
GSFC Technology Development Center Report .....	280
Haystack Observatory Technology Development Center .....	283
IAA Technology Development Center Report 2011 .....	287
Technology Development Center at NICT .....	291
Onsala Space Observatory – IVS Technology Development Center .....	295
 <b>Bibliography</b> .....	 <b>299</b>
Bibliography .....	301
 <b>IVS Information</b> .....	 <b>315</b>
IVS Terms of Reference .....	317
IVS Member Organizations .....	327
IVS Affiliated Organizations .....	329
IVS Associate Members .....	330
IVS Permanent Components .....	340
Addresses of Institutions of Authors Contributing to this Report .....	344
List of Acronyms .....	351



# About IVS

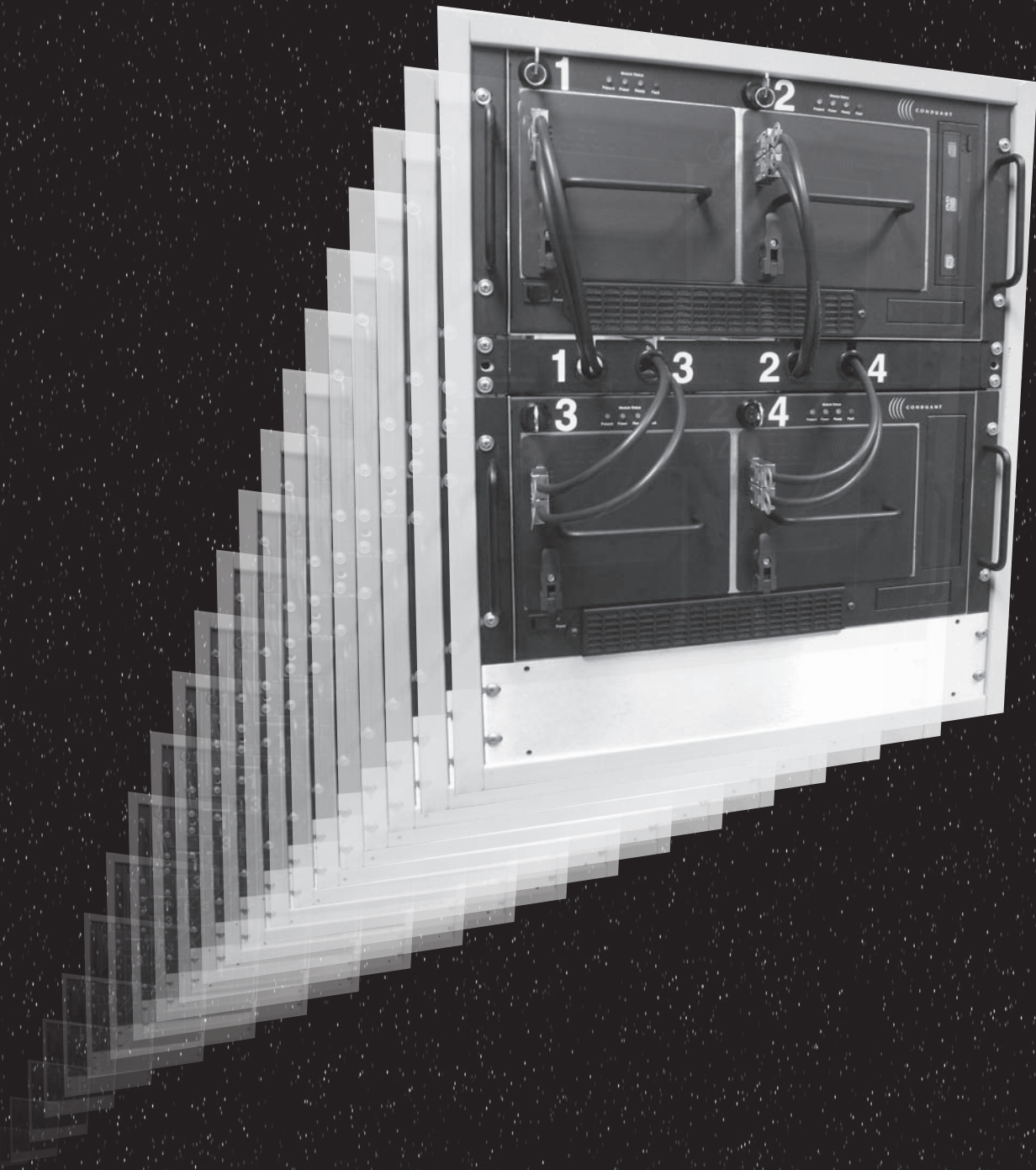

**About IVS**

# IVS Organization

## Objectives

IVS is an international collaboration of organizations which operate or support Very Long Baseline Interferometry (VLBI) components. The goals are:

1. To provide a service to support geodetic, geophysical and astrometric research and operational activities.
2. To promote research and development activities in all aspects of the geodetic and astrometric VLBI technique.
3. To interact with the community of users of VLBI products and to integrate VLBI into a global Earth observing system.

## The IVS

- Interacts closely with the IERS, which is tasked by IAU and IUGG with maintaining the international celestial and terrestrial reference frames (ICRF and ITRF),
- coordinates VLBI observing programs,
- sets performance standards for the observing stations,
- establishes conventions for data formats and products,
- issues recommendations for analysis software,
- sets standards for analysis documentation,
- institutes appropriate product delivery methods in order to insure suitable product quality and timeliness.

## Realization And Status Of IVS

### IVS consists of

- 31 Network Stations, acquiring high performance VLBI data,
- 3 Operation Centers, coordinating the activities of a network of Network Stations,
- 6 Correlators, processing the acquired data, providing feedback to the stations and providing processed data to analysts,
- 6 Data Centers, distributing products to users, providing storage and archiving functions,
- 27 Analysis Centers, analyzing the data and producing the results and products,
- 7 Technology Development Centers, developing new VLBI technology,
- 1 Coordinating Center, coordinating daily and long term activities.

### Altogether

- 81 Permanent Components, representing 41 institutions in 20 countries,
- ~280 Associate Members.

### In addition the IVS has:

- Directing Board, determining policies, standards and goals; the board is composed of 15 members (elected and ex officio), including
- Coordinators for the network, analysis and technology.

## ORGANIZATION OF INTERNATIONAL VLBI SERVICE

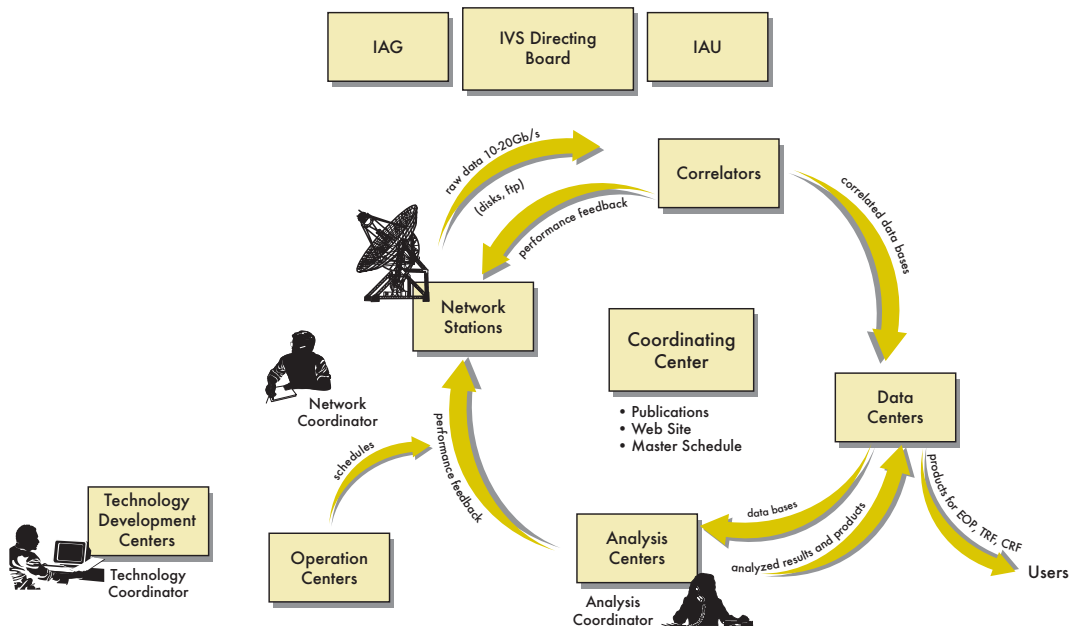

## IVS Member Organizations

The following organizations contribute to IVS by supporting one or more IVS components. They are considered IVS Members. Listed alphabetically by country.

Organization	Country
Geoscience Australia	Australia
University of Tasmania	Australia
CSIRO	Australia
Vienna University of Technology	Austria
Centro de Rádio Astronomia e Aplicações Espaciais	Brazil
Geodetic Survey Division, Natural Resources Canada	Canada
Dominion Radio Astrophysical Observatory	Canada
Universidad de Concepción	Chile
Instituto Geográfico Militar	Chile
Chinese Academy of Sciences	China
Observatoire de Paris	France
Observatoire de Bordeaux	France
Deutsches Geodätisches Forschungsinstitut	Germany
Bundesamt für Kartographie und Geodäsie	Germany
Institut für Geodäsie und Geoinformation der Universität Bonn	Germany
Forschungseinrichtung Satellitengeodäsie, TU-Munich	Germany
Max-Planck-Institut für Radioastronomie	Germany
Istituto di Radioastronomia INAF	Italy
Agenzia Spaziale Italiana	Italy
Politecnico di Milano DIAR	Italy
Geospatial Information Authority of Japan	Japan
National Institute of Information and Communications Technology	Japan
National Astronomical Observatory of Japan	Japan
National Institute of Polar Research	Japan
Auckland University of Technology	New Zealand
Norwegian Defence Research Establishment	Norway
Norwegian Mapping Authority	Norway
Astronomical Institute of St.-Petersburg University	Russia
Institute of Applied Astronomy	Russia
Pulkovo Observatory	Russia
Sternberg Astronomical Institute of Moscow State University	Russia

Organization	Country
Hartebeesthoek Radio Astronomy Observatory	South Africa
Korea Astronomy and Space Science Institute	South Korea
Instituto Geográfico Nacional	Spain
Chalmers University of Technology	Sweden
Karadeniz Technical University	Turkey
Main Astronomical Observatory, National Academy of Sciences, Kiev	Ukraine
Laboratory of Radioastronomy of Crimean Astrophysical Observatory	Ukraine
NASA Goddard Space Flight Center	USA
U. S. Naval Observatory	USA
Jet Propulsion Laboratory	USA

## IVS Affiliated Organizations

The following organizations cooperate with IVS on issues of common interest, but do not support an IVS component. Affiliated Organizations express an interest in establishing and maintaining a strong working association with IVS to mutual benefit. Listed alphabetically by country.

Organization	Country
Australian National University	Australia
University of New Brunswick	Canada
FÖMI Satellite Geodetic Observatory	Hungary
Joint Institute for VLBI in Europe (JIVE)	Netherlands
Westerbork Observatory	Netherlands
National Radio Astronomy Observatory	USA

## Products

### The VLBI technique contributes uniquely to

- Definition and realization of the International Celestial Reference Frame (ICRF)
- Monitoring of Universal Time (UT1) and length of day (LOD)
- Monitoring the coordinates of the celestial pole (nutation and precession)

### Further significant products are

- All components of Earth Orientation Parameters at regular intervals
- Station coordinates and velocity vectors for the realization and maintenance of the International Terrestrial Reference Frame (ITRF)

All VLBI data and results in appropriate formats are archived in data centers and publicly available for research in related areas of geodesy, geophysics and astrometry.

# IVS Component Map

## IVS Components by Country

Country	Qty.
Australia	3
Austria	1
Brazil	1
Canada	1
Chile	1
China	3
France	3
Germany	8
Italy	8
Japan	13
New Zealand	1
Norway	4
Russia	9
South Africa	1
South Korea	1
Spain	1
Sweden	3
Turkey	1
Ukraine	2
USA	16
<b>Total</b>	<b>81</b>

A complete list of IVS Permanent Components is in the IVS Information section of this volume.

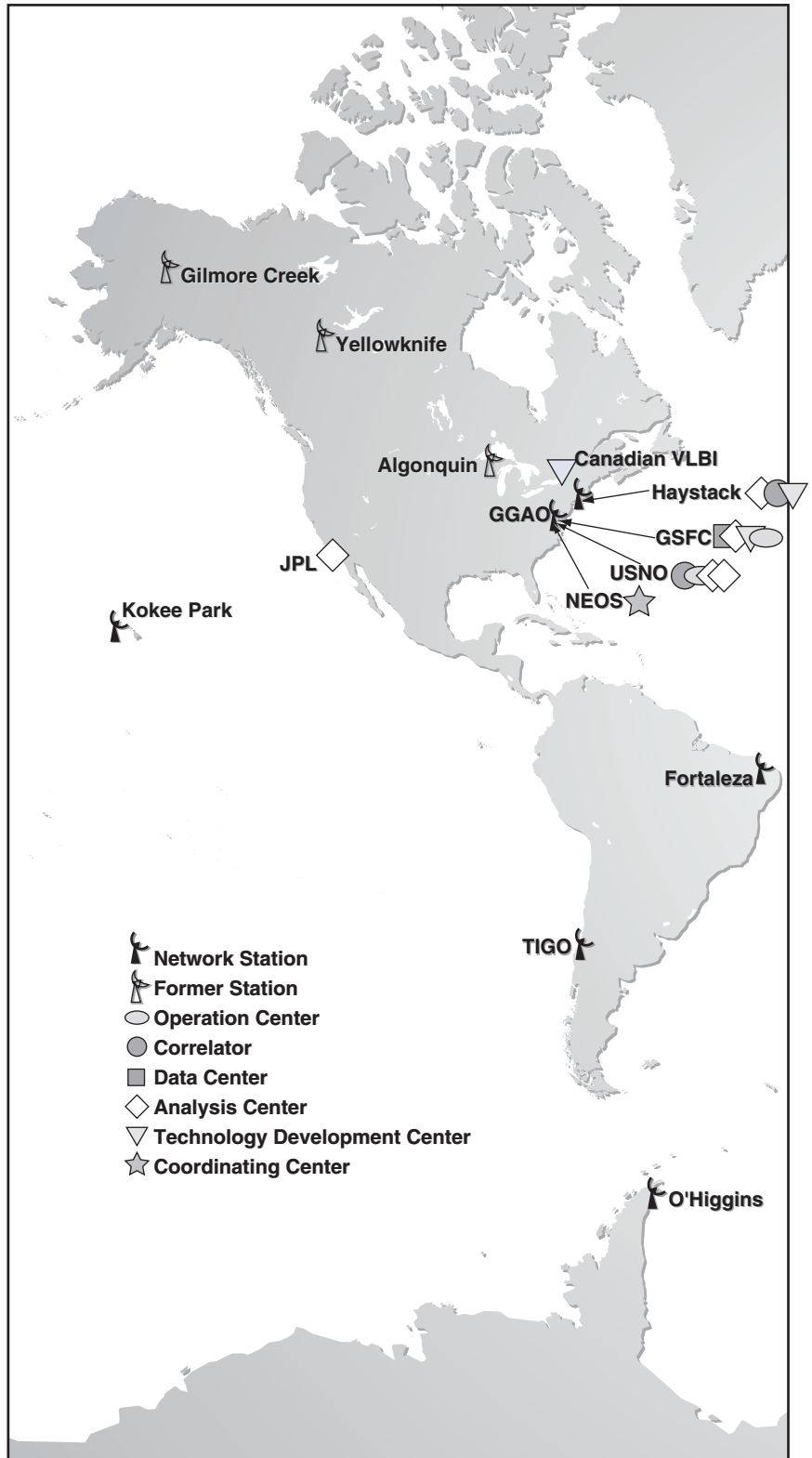



# IVS Directing Board



NAME: Harald Schuh  
AFFILIATION: Vienna University of Technology, Austria  
POSITION: Acting Chair and IAG Representative  
TERM: ex officio



NAME: Dirk Behrend  
AFFILIATION: NVI, Inc./Goddard Space Flight Center, USA  
POSITION: Coordinating Center Director  
TERM: ex officio



NAME: Jesús Gómez González  
AFFILIATION: National Geographic Institute of Spain  
POSITION: At Large Member  
TERM: Feb 2011 to Feb 2013



NAME: Alessandra Bertarini  
AFFILIATION: University of Bonn, Germany  
POSITION: Correlators and Operation Centers Representative  
TERM: Feb 2011 to Feb 2015



NAME: Rüdiger Haas  
AFFILIATION: Chalmers University of Technology, Sweden  
POSITION: Technology Development Centers Representative  
TERM: Feb 2009 to Feb 2013



NAME: Patrick Charlot  
AFFILIATION: Bordeaux Observatory, France  
POSITION: IAU Representative  
TERM: ex officio



NAME: Hayo Hase  
AFFILIATION: Bundesamt für Kartographie und Geodäsie/TIGO, Germany/Chile  
POSITION: Networks Representative  
TERM: Feb 2011 to Feb 2015





NAME: Ed Himwich  
 AFFILIATION: NVI, Inc./Goddard Space Flight Center, USA  
 POSITION: Network Coordinator  
 TERM: permanent



NAME: Fengchun Shu  
 AFFILIATION: Shanghai Astronomical Observatory, China  
 POSITION: At Large Member  
 TERM: Feb 2011 to Feb 2013



NAME: Shinobu Kurihara  
 AFFILIATION: Geographical Survey Institute, Japan  
 POSITION: At Large Member  
 TERM: (Feb 2011) to Feb 2013



NAME: Oleg Titov  
 AFFILIATION: Geoscience Australia, Australia  
 POSITION: Analysis and Data Centers Representative  
 TERM: Feb 2009 to Feb 2013



NAME: Chopo Ma  
 AFFILIATION: NASA Goddard Space Flight Center, USA  
 POSITION: IERS Representative  
 TERM: ex officio



NAME: Gino Tuccari  
 AFFILIATION: Istituto di Radioastronomia, Italy  
 POSITION: Networks Representative  
 TERM: Feb 2009 to Feb 2013

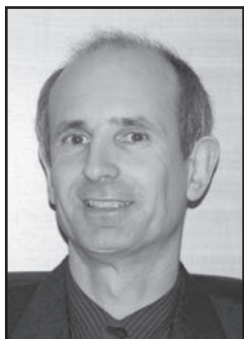

NAME: Axel Nothnagel  
 AFFILIATION: University of Bonn, Germany  
 POSITION: Analysis Coordinator  
 TERM: permanent



NAME: Alan Whitney  
 AFFILIATION: Haystack Observatory, USA  
 POSITION: Technology Coordinator  
 TERM: permanent

## Harald Schuh

Institute of Geodesy and Geophysics, Vienna University of Technology, Austria

With the 2011 Annual Report the IVS components report about their progress and activities which were conducted during the service's thirteenth year of existence. I would like to thank all IVS Associate Members for their contributions over the course of the year, in particular for providing their reports in time. Timely appearance of the Annual Report is always an ambitious goal and is highly appreciated for maintaining this volume as a real information exchange tool for the community and related groups. I thank the editors for the timely release.

In 2011 IVS observing activities remained at the same high level as in previous years, testament to the optimized coordination by the Coordinating Center and strong support from all components despite the limited resources and failures at a few aging radio telescopes. I would like to thank the staff of the Coordinating Center who bear much responsibility and carry a heavy burden for the entire service activities. Day-to-day work is done continuously by the Network Stations, the Correlators, the Data Centers, and the Analysis Centers and is the basis for the regular provision of precise and reliable IVS products. Here I would like to emphasize those activities performed in 2011 that go beyond the normal work load.

## IVS Contribution to the Global Geodetic Observing System (GGOS)

In 2005 the intergovernmental Group on Earth Observations (GEO) was formed. This group initiated the creation of a Global Earth Observing System of Systems (GEOSS) for monitoring and understanding global change. The International Association of Geodesy (IAG) contributes to this multi-national and multi-institutional effort with the Global Geodetic Observing System (GGOS). Based on the well-established, international space-geodetic services GGOS will provide the most precise terrestrial and celestial reference frames that are needed as a stable reference to monitor any kind of changes on Earth and in space.

Integration and combination in the framework of GGOS is the main challenge for the international geodesy in this decade. GGOS goes beyond the integration of the geometric techniques (VLBI, SLR, GNSS, DORIS) as it includes also techniques measuring terrestrial gravity, the global Earth gravity field, sea level, and also the magnetic

field. Thus, a consistent combination of all geometric and physical techniques will be required. GGOS plays an essential role in helping to solve environmental and societal problems. Many tasks such as establishing a unified global height system or open questions related to global change, sea level rise, or the prevention of natural hazards need precise reference frames and exact geodetic measurements. VLBI can give a critical contribution to GGOS by its relation to a quasi-inertial celestial reference frame and its unique ability to measure long-term UT1-UTC and precession/nutation. One of the IVS main tasks in 2011 was to continue its contribution as an efficient partner within GGOS. Several GGOS events were attended in 2011 with presentations about the IVS and its next generation VLBI2010 system; the IVS is well represented in the GGOS Steering Committee. Since August 2011 GGOS itself has been subject to a re-organization with new entities formed (GGOS Consortium, GGOS Coordinating Board)—this process is still ongoing and the IVS is actively contributing.

## VLBI2010 Committee (V2C) and VLBI2010 Project Executive Group (V2PEG)

In recent years the IVS has developed the concept and specifications of a next generation VLBI system called VLBI2010. The goals of the new system are to achieve (on scales up to the size of the Earth):

- 1 mm position accuracy,
- 0.1 mm/yr velocity accuracy,
- continuous observations, and
- results available in near real-time.

The VLBI2010 Committee (V2C), chaired by Bill Petrichenko, was established in 2005. It is tasked with promoting the goals set by the VLBI2010 Report released by the IVS Working Group 3 "VLBI2010: Current and Future Requirements for Geodetic VLBI Systems." All results have been summarized in the excellent VLBI2010 Progress Report with recommendations that can be used as benchmark for new VLBI systems. Since the VLBI2010 Progress Report was finalized in spring 2009 and put on the IVS Web site (<ftp://ivsc.gsfc.nasa.gov/pub/misc/V2C/TM-2009-214180.pdf>) the V2C activities have continued with a lot of further simulations and technical studies. I would like to thank all members of the V2C for taking over the responsible leading role in the realization of the VLBI2010 visions.

VLBI2010 is supposed to develop not only the visions but also very detailed specifications for future VLBI systems. Now, the task for the IVS is the realization of the VLBI2010 concept. To support the implementation of VLBI2010 and

to actively contact governmental entities and funding organizations the VLBI2010 Project Executive Group (V2PEG) under the leadership of Hayo Hase continued its activities in 2011. Several letters of support were sent to government bodies and funding agencies all over the world and an update of the so-called station survey was requested from the IVS network stations in December 2011. Based on this questionnaire very useful information was obtained about the status of the planning process concerning the transition to VLBI2010 at the various observing stations. Right now several countries have already decided to develop or purchase new VLBI systems. We highly appreciate that the following agencies got approval of new VLBI2010-type radio telescopes in 2011: National Geographic Information Institute (NGII), South Korea; Geospatial Information Authority of Japan (GSI); Finnish Geodetic Institute (FGI); University of Kazan, Russia; and Norwegian Mapping Authority (NMA). I would like to congratulate them on the ambitious projects and wish them success for the realization in the next years. Thus, already thirteen VLBI2010 antennas have been approved with more proposals under consideration or already in review in countries like China, France, Saudi Arabia, and Sweden (while writing this report in March 2012 further proposals for new radio telescopes got approved, for instance, in Sweden and China). With new antennas the global coverage of geodetic VLBI is getting better; but it is still far from being optimal, in particular more VLBI sites in the southern hemisphere would be more than welcome.

### **IVS Working Group 4 on “VLBI Data Structures”**

The IVS Working Group on “VLBI Data Structures” chaired by John Gipson was established in September 2007 as a response to the strong need of new, common VLBI data structures. This Working Group examines the data structure currently used in VLBI data processing and develops the data structure needed in the future. WG4 is now close to realize all its goals and to provide the new data format strongly required by the IVS Analysis Centers.

### **IVS Working Group 5 on “Space Science Applications”**

The current mandate of the WG5, chaired by Leonid Gurvits, comprises the following tasks:

1. To investigate synergies in scientific and technological areas between the IVS core activities and VLBI

experiments in application to planetary and space science missions.

2. To determine areas of VLBI support of planetary and space science missions where experiments conducted by the IVS (possibly together with other VLBI networks) can be mutually beneficial.
3. To investigate desirability and feasibility of establishing a mission-specific liaison between IVS and appropriate space agencies and organizations involved in planetary and space science missions.

Due to cancellations or postponement of several relevant space missions the work of WG5 was also delayed, but it is anticipated that a first report of WG5 will be published in 2012.

### **IVS Working Group 6 on “VLBI Education and Training”**

The IVS Directing Board established in March 2009 the Working Group 6 on “Education and Training” chaired by Rüdiger Haas. The general aim of IVS WG6 is to support education and training in the field of geodetic and astrometric VLBI, in order to maintain and pass on the expertise in this field to the next generations.

The Terms of Reference of IVS WG6 are:

1. To establish contacts to education institutions in geodesy and geosciences worldwide with the aim to raise interest in geodetic VLBI among students.
2. To develop ideas for education material that can be distributed to education institutions.
3. To seek funding to organize training in form of, for instance, IVS summer schools for Master and PhD students.

Proposals for a VLBI summer school were submitted in 2011 which hopefully can be organized in the near future.

### **Events and Highlights in 2011**

From March 29 to 31, 2011 the 20th European VLBI for Geodesy and Astrometry (EVGA) Working Meeting and an IVS Analysis Workshop were held at Max-Planck-Institute for Radio Astronomy (MPIfR) in Bonn, Germany. The scientific organization of the meetings was performed in close collaboration with the IVS Analysis Coordinator and Chair of the EVGA, Axel Nothnagel. The local organizing committee was led by Walter Alef from Max-Planck-Institute who was supported by his colleagues from MPIfR together with the VLBI group of the Institute of Geodesy and Geoinformation (IGG) of Bonn University. It was extremely interesting to listen to the talk about

# IVS Chair's Report Continued

'EVGA - Looking back at the early beginnings' delivered by James Campbell who had been leading the European VLBI activities over decades and for sure is the person who knows best about the history of European geodetic VLBI. It should also be mentioned here that the Proceedings of the 20th EVGA Working Meeting have been printed already in July 2011 (<http://www.mpifr-bonn.mpg.de/div/meetings/20thEVGA/pdf-files/EVGA-proceedings.pdf>) proving the efficiency of the local organizers.

Another highlight in 2011 certainly was the continuous VLBI session CONT11 that took place in the second half of September 2011 and was observed on a network of 13 stations. Remote-control of several radio telescopes allowed unattended operation (e.g., during nights). Due to the high number of baselines to be correlated the correlation was just finished recently (as of March 2012) but as the CONT sessions have always shown the best possible performance of international VLBI and provided the most interesting and valuable results we expect another bunch of extremely useful VLBI data.

On 21–22 October 2011, the first IVS Retreat and on 23 October 2011, the 26th IVS Directing Board Meeting were held at Hohe Wand, a table mountain 60 kilometers southwest of Vienna. For the Retreat the Board was augmented by invited guests, namely, Johannes Böhm, Thomas Hobiger, Jim Lovell, and Arthur Niell. The focus of the Retreat was placed on a review and update of the IVS Terms of Reference (ToR). Periodic reviews of the IVS organization and its mandate, functions, and components are actually a requirement according to the ToR. The conclusions of a thorough final discussion about the IVS strategic goals and tasks were summarized in the 'Hohe Wand Declaration' shown just after the Chair's Report in this volume.

One new Operational Analysis Center (GSI, Tsukuba, Japan) and two new IVS Associate Analysis Centers (Norwegian Mapping Agency (NMA), and Politecnico di Milano, Italy) were approved in 2011. One 'Special Analysis Center for Specific Observing Sessions' SAC-SOS (Institute of Geodesy and Geophysics, Vienna, Austria), and one Observing Station (Parkes CSIRO Radio Telescope, Australia) were also accepted as new IVS components.

Summary information about all IVS events and activities is available on the IVS homepage <http://ivscg.gsfc.nasa.gov> and in the IVS Newsletters 29, 30, and 31. The Newsletter is an excellent means to transfer information to everybody. The editor team, Dirk Behrend, Hayo Hase, and Heidi Johnson, presented interesting and up-to-date information. They once again did an excellent job, which is highly appreciated.

Another feature should be mentioned here which provides excellent information about on-going VLBI sessions: it is the IVS live-stream set up by the VLBI group of Bordeaux Observatory that can be watched under <http://ivslive.obs.u-bordeaux1.fr/>.

Finally it should be recognized that in a special issue of *Journal of Geodesy* (2011, Volume 85, Number 7) six valuable scientific manuscripts were published that concentrate on using VLBI observations from the CONT08 campaign which took place in August 2008. Such an intensive VLBI campaign provides excellent data to investigate geodetic and geophysical phenomena of the same period employing meteorological or other space-geodetic observations. All authors and in particular the guest editors of this special issue, Axel Nothnagel, Urs Hugentobler, and David Salstein shall be acknowledged here.

## The Directing Board in 2011

In February 2011, the Directing Board welcomed the two new elected representative members for the term 2011 to 2015; namely, Hayo Hase (Germany/Chile) as re-elected Networks representative and Alessandra Bertarini (Germany) as Correlators and Operations Centers representative. In addition, Shinobu Kurihara (Geospatial Information Authority of Japan), Fengchun Shu (Shanghai Astronomical Observatory, China), and Jesús Gómez-González (National Geographical Institute of Spain) commenced their terms (2011 to 2013) as the new at-large members of the Board. I am very pleased that the IVS Directing Board is well balanced in its composition with respect to global coverage, with respect to component representation, and with respect to a good mixture of experienced and young members.

## IVS Events in the Coming Year 2012

In the week of March 4, 2011, the 7th IVS General Meeting will be held in Madrid, Spain; i.e., in the country where presently the planning and establishment of four new VLBI radio telescopes is taking place in the frame of the Spanish/Portuguese RAEGE project.

# Special Reports

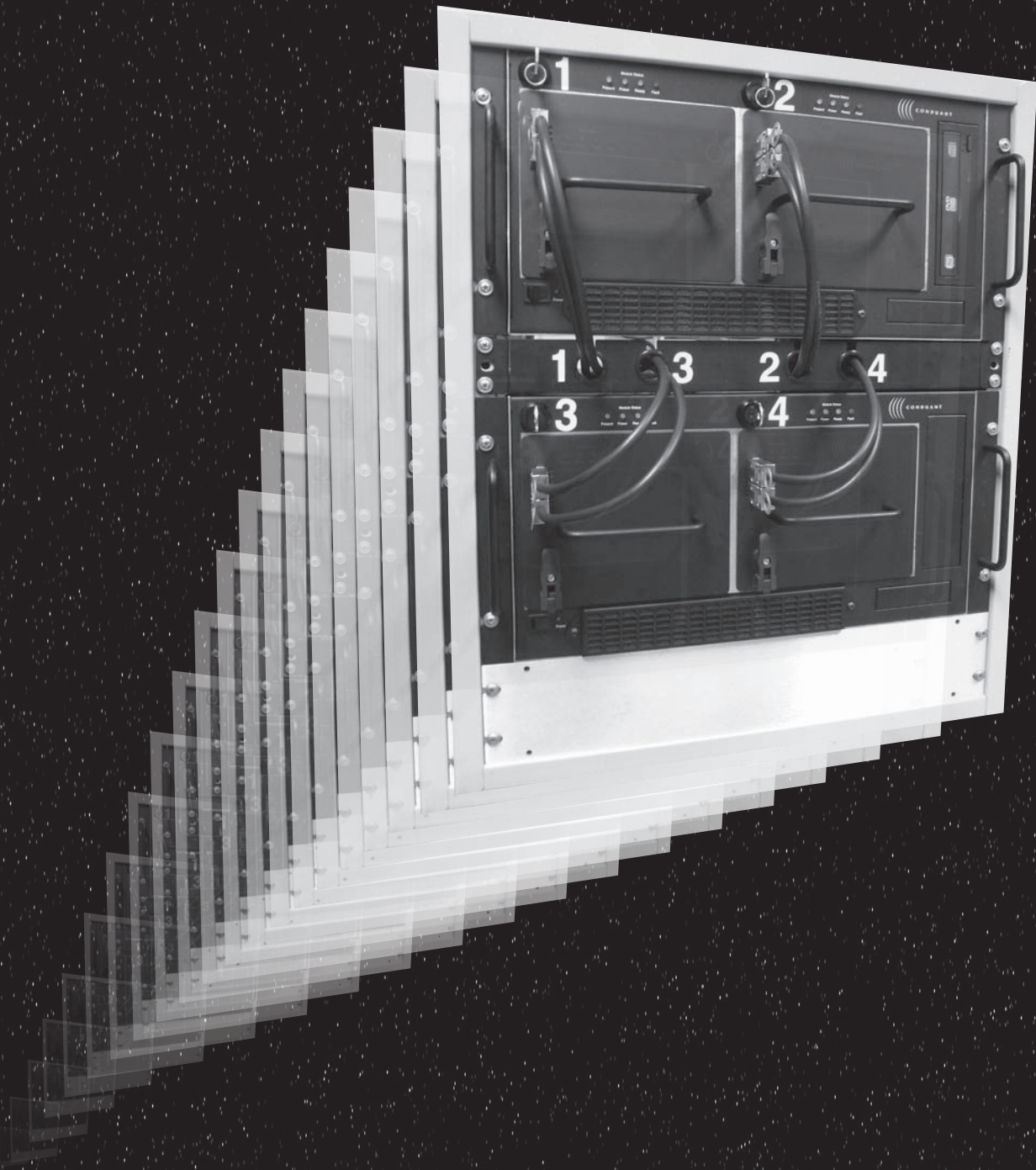

# Special Reports



## Hohe Wand Declaration

From 21–22 September 2011 the IVS held a retreat in the Gutenstein Alps in Lower Austria, a good hour's drive southwest of Vienna. The venue was an *Alpengasthof* ('alpine guesthouse') within the Hohe Wand nature park. For the retreat, the IVS Directing Board was augmented by several invited guests: Johannes Böhm, Thomas Hobiger, Jim Lovell, and Arthur Niell (see Figure 1), resulting in an overall group strength of 18 participants.



Figure 1. Participants of the IVS retreat at Hohe Wand, Austria.

The focus of the retreat was placed on a review and update of the IVS Terms of Reference (ToR). Periodic reviews of the IVS organization and its mandate, functions, and components are actually a requirement according to the ToR. The retreat participants went through the existing ToR sentence by sentence and discussed the continued validity of the contents. When needed, the ToR were rephrased or the formulations were simplified. In addition, a few minor additions and deletions were done. None of the changes were critical or controversial in nature. The additions were mostly with respect to the Global Geodetic Observing System (GGOS); perhaps the only major update was the addition of a second Analysis Center representative on the Board. The revised ToR were approved by the Board in the subsequent Board meeting and then officially ratified by the International Association of Geodesy (IAG) in December. The revised ToR can be found in the IVS information section of this volume.

A second major discussion block dealt with focus areas for future IVS work and activities. The participants felt that emphasis should be put on improving quality control, internal and external outreach, VLBI2010 infrastructure, real-time observation and product creation (including automation), and expanding research and research fields. The results of the discussion were compiled into a declaration that was subsequently approved by the Board. Please peruse the reproduction of the declaration below.

**Declaration of the Participants of the IVS Retreat at  
Hohe Wand, Austria from 21–22 September 2011**

We, the eighteen participants of the International VLBI Service for Geodesy and Astrometry (IVS) Retreat at Hohe Wand, Austria, met on 21–22 September 2011 to review the IVS organization and its mandate, functions, and components, as well as to define focus areas for future IVS work and activities. We

**recognize**

- that the global framework for geodetic activities has evolved since the inception of the service through the establishment of the Global Geodetic Observing System (GGOS);
- that the IVS data and products are also GGOS data and products;
- that the increased requirements, as mandated by GGOS, for position accuracy of 1 mm and velocity accuracy of 0.1 mm/year by the year 2020 can only be achieved by the next-generation VLBI system (VLBI2010); and
- that the IVS organization, mandate, functions, and components as outlined in the IVS Terms of Reference (ToR) continue to fulfill the requirements of the global geodetic/astrometric VLBI science and the associated user communities;

**recommend**

- that the development of the next generation VLBI system be vigorously advanced, and that the corresponding VLBI2010 infrastructure be established on a global basis;
- that the quality control of VLBI data and products be improved;
- that internal and external outreach activities be enhanced;
- that real-time observation and product creation (including automation) be advanced to an operational state; and
- that both research activities and research fields-of-interest be expanded.

*Hohe Wand, Austria  
22 September 2011*



# IVS Coordination

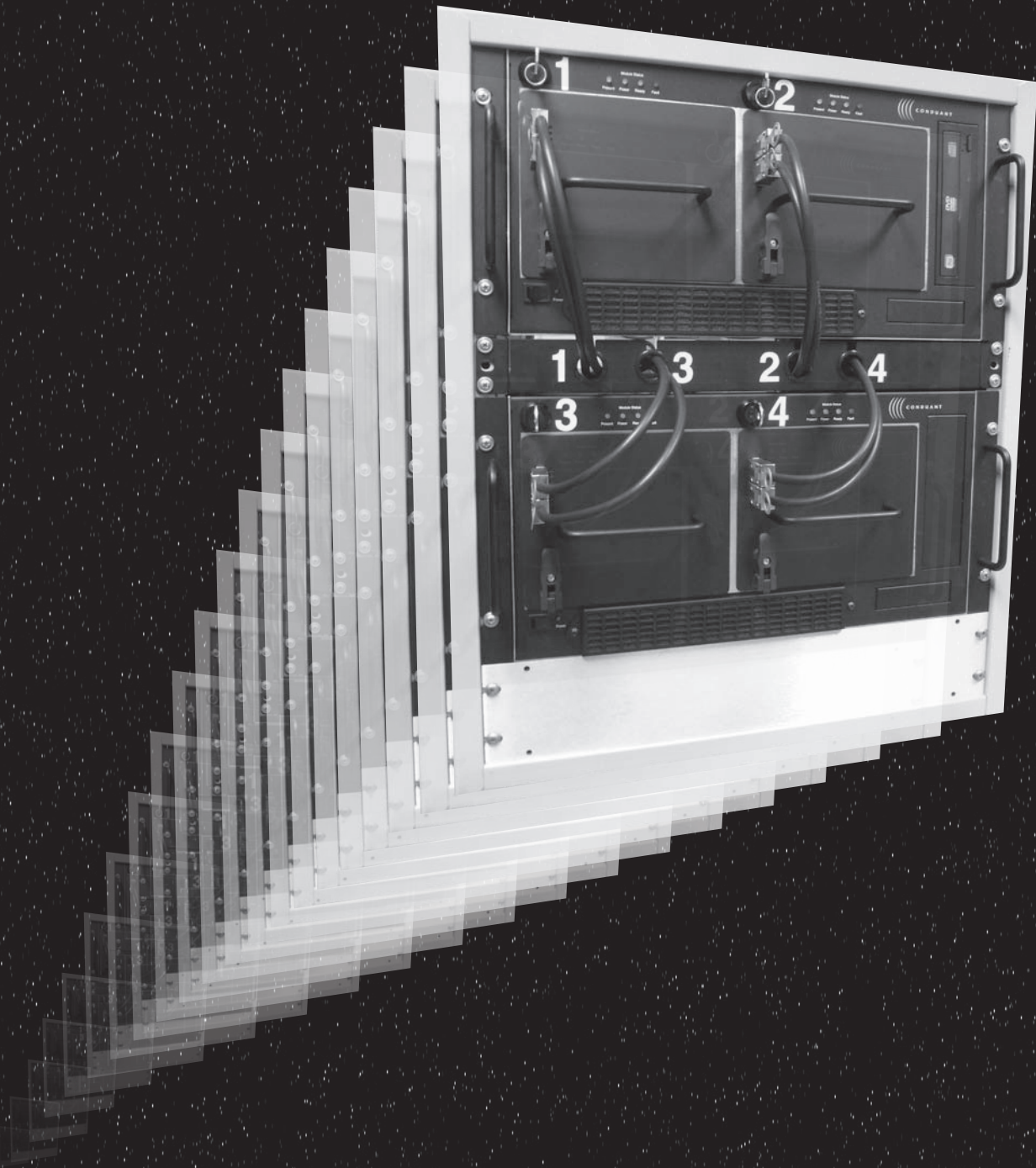

**IVS Coordination**



# Coordinating Center Report

*Dirk Behrend*

## Abstract

This report summarizes the activities of the IVS Coordinating Center during the year 2011 and forecasts activities planned for the year 2012.

## 1. Coordinating Center Operation

The IVS Coordinating Center is based at the Goddard Space Flight Center and is operated by NEOS (National Earth Orientation Service), a joint effort for VLBI by the U.S. Naval Observatory and the NASA Goddard Space Flight Center.

The mission of the Coordinating Center is to provide communications and information for the IVS community and the greater scientific community and to coordinate the day-to-day and long-term activities of IVS.

The Web server for the Coordinating Center is provided by Goddard. The address is

<http://ivscc.gsfc.nasa.gov>

## 2. Activities during 2011

During the period from January through December 2011, the Coordinating Center supported the following IVS activities:

- Directing Board support: Coordinated, with local committees, two IVS Directing Board meetings, in Bonn, Germany (April 2011) and Hohe Wand, Austria (September 2011). Notes from each meeting were published on the IVS Web site.
- Communications support: Maintained the Web pages, e-mail lists, and Web-based mail archive files. Generated analysis reports and included them into the 24-hour session Web pages. Maintained Intensive session Web pages.
- Publications: Published the 2010 Annual Report in spring 2011. Published three editions of the IVS Newsletter in April, August, and December 2011. All publications are available electronically as well as in print form.
- Observing Program Committee (OPC): Coordinated meetings of the OPC to monitor the observing program, review problems and issues, and discuss changes.
- 2011 Master Schedule: Generated and maintained the master observing schedule for 2011. Coordinated VLBI resources for observing time, correlator usage, and disk modules. Coordinated the usage of Mark 5 systems at IVS stations and efficient deployment of disk modules. Coordinated the continuous VLBI campaign 2011 (CONT11).
- 2012 Master Schedule: Generated the proposed master schedule for 2012 and received approval from the Observing Program Committee.
- VLBI2010: Supported the activities of the VLBI2010 Committee (V2C) and the VLBI2010 Project Executive Group (V2PEG). Worked with the Local Committee and the Program

Committee to prepare the VLBI2010 Workshop on Technical Specifications to be held in Bad Kötzing, Germany in March 2012.

- Meetings: Coordinated, with the Local Committee, the sixth IVS Technical Operations Workshop, held at Haystack Observatory in May 2011. Chaired the Program Committee for the meeting.

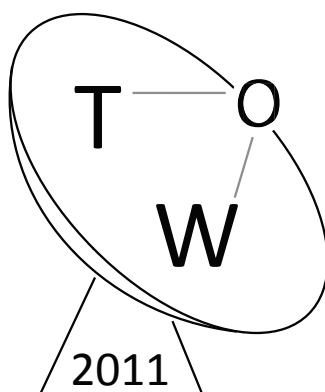

Figure 1. Logo (left) and participants (right) of the sixth IVS Technical Operations Workshop held at MIT Haystack Observatory in May 2011. More information about the workshop can be found on the IVS Web site at <http://ivscc.gsfc.nasa.gov/meetings/tow2011/>.

Coordinated, with the Local Committee, the seventh IVS General Meeting, to be held in Madrid, Spain in March 2012. Chaired the Program Committee for the meeting.

### 3. CONT11 Campaign

The Continuous VLBI Campaign 2011 (CONT11) was successfully observed in late summer to early fall. Thirteen IVS stations (see Figure 2) observed for 15 consecutive days at a rate of 512 Mbps in the time frame of September 15-29, 2011. The observing was done on the basis of UT days with each CONT11 day running from 0 UT to 24 UT. UT day observing is needed to make the most accurate combination and comparison of results from other techniques.

The Coordinating Center, in collaboration with the OPC, was responsible for:

- the overall planning and coordination of the campaign,
- the media usage and shipment schedule, and
- the preparation of the detailed observing schedules and notes.

As was done with the CONT08 campaign, all CONT11 data are being correlated at the Washington Correlator. The release of the correlated data is expected for early 2012. Performing the correlation at a single place significantly eased the logistics involved with module handling at the correlators and the stations.

The staggered station check times that were successfully introduced with the CONT08 campaign were also repeated: the daily station checks were decoupled from the change of schedules and were instead introduced at convenient and well-coordinated times for the stations (i.e., different daily check times for each station) avoiding observational gaps overall. Such gaps existed

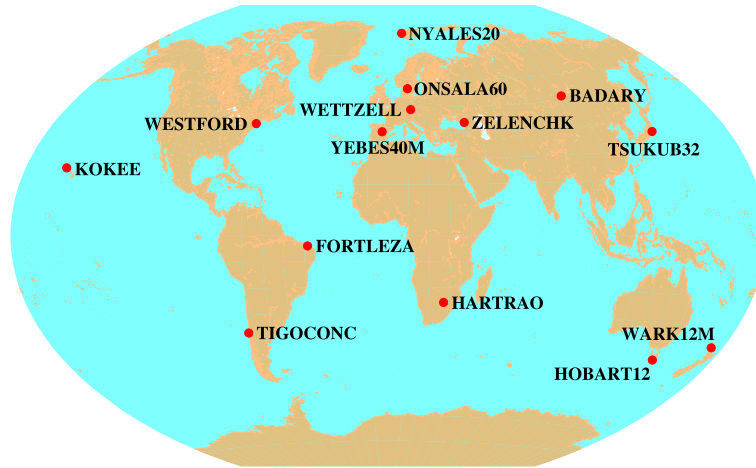

Figure 2. Geographical distribution of the 13 CONT11 stations. From the original 14 stations, Warkworth had to drop out because of technical problems.

in pre-CONT08 continuous campaigns (usually a 30-minute break between individual observing days) and resulted in unrealistic peaks in the sub-daily EOP time series derived from the CONT data.

More information about the CONT11 campaign can be found on the IVS Web site under the URL <http://ivscc.gsfc.nasa.gov/program/cont11>.

#### 4. Staff

The staff of the Coordinating Center is drawn from individuals who work at Goddard. The staff and their responsibilities are listed in Table 1.

Table 1. IVS Coordinating Center staff.

Name	Title	Responsibilities
Dirk Behrend	Director	Web site and e-mail system maintenance, Directing Board support, meetings, publications, session Web page monitoring
Cynthia Thomas	Operation Manager	Master schedules (current year), resource management and monitoring, meeting and travel support, special sessions
Frank Gomez	Web Manager	Web server administration, mail system maintenance, Data Center support, session processing scripts, mirror site liaison
Karen Bayer	General Programmer and Editor	Publication processing programs, LaTeX support and editing, session Web page support and scripts

## 5. Plans for 2012

The Coordinating Center plans for 2012 include the following:

- Maintain IVS Web site and e-mail system.
- Publish the 2011 Annual Report (this volume).
- Coordinate, with the local committee, the VLBI2010 Workshop on Technical Specifications to be held in Bad Kötzing, Germany in March 2012.
- Coordinate, with the local committee, the seventh IVS General Meeting to be held in Madrid, Spain in March 2012.
- Support Directing Board meetings in 2012.
- Coordinate the 2012 master observing schedules and IVS resources.
- Publish Newsletter issues in April, August, and December.
- Support the VLBI2010 activities of the V2C and V2PEG.

# Analysis Coordinator Report

*A. Nothnagel, T. Artz*

## Abstract

IVS analysis coordination issues in 2011 are reported here. Routine Earth orientation parameter combinations on the basis of datum-free normal equations are being carried out by the IVS Combination Center at BKG, Frankfurt a.M., Germany. The IVS Analysis Coordinator is responsible for consistency of the input data and requires strict adherence to models and conventions.

## 1. General Issues

The “Twelfth IVS Analysis Workshop” was hosted by the Max-Planck-Institute for Radio Astronomy in Bonn, Germany, on March 31, 2011, in connection with the 20th Meeting of the European VLBI Group for Geodesy and Astrometry (EVGA). The coordination of IVS routine data analysis was discussed as well as developments for improving geodetic and astrometric data analysis in general.

The timeliness of the submission of the SINEX files from the operational IVS Analysis Centers (ACs) to the IVS Data Centers has improved considerably since the last report, although individual analysis centers still attract attention by not providing input according to their initial proposals. With more operational analysis centers coming online, the less reliable ACs may be subject to a more rigorous assessment.

It is well known that the treatment of the sub-daily tidal Earth rotation parameter variations and the introduction of harmonic site position variations may generate alias effects in the daily EOP time series. During the Analysis Workshop, Thomas Artz presented an empirical sub-daily EOP model combined from VLBI and GPS observations [1]. This model comprises the strengths of both techniques and compensates at least some of the deficits which are inherent to empirical models. The model should be tested by the IVS ACs for use in routine IVS data analysis.

The attendants of the meeting discussed the impact of the IERS Conventions 2010 [5] on IVS analyses. The main issues are the new mean pole model, the S1/S2 tides, the Earth’s libration, and the ocean pole tide. These effects are already included in the Calc/Solve analysis package and should also be incorporated into the other independent packages.

Concerning atmospheric gradient modelling, there are two models available, the so-called Macmillan model [3] and the Chen and Herring model [2]. They are very similar in formulation and in the results, but a consistent use of one of these two models throughout the IVS should be achieved. For the decision, it should be taken into account that the IGS uses the Chen and Herring model and that for combination of VLBI results with GPS the models should be identical. It was agreed that it would be advisable to use the Chen and Herring model as the IVS conventional model but that tests will have to be done on the impact of such a move. The results should be discussed at the next IVS Analysis Workshop in Madrid in 2012.

The decision on the a priori gradients was less critical. All participants agreed unanimously that the Goddard Data Assimilation Office (DAO) results should be used as the conventional IVS a priori gradient model. Nothing has happened concerning the reference pressure for atmospheric loading, which is under the responsibility of the Special Bureau of Loading of the International Earth Rotation and Reference Systems Service (IERS).

## 2. IVS Operational Data Analysis and Combination

Since October 1, 2009, the operational combination has been carried out by the IVS Combination Center at the German Bundesamt für Kartographie und Geodäsie (BKG) in Frankfurt a.M. (see separate report by BKG/DGFI). The input to these combinations are datum-free (constraint-free) normal equation systems in SINEX format (Solution Independent Exchange format). The nutation representation in the IAU2000 paradigm,  $dX$  and  $dY$ , is now the standard. For users of the old system, a separate table is generated through a transformation.

At the 12th IVS Analysis Workshop it was also agreed by all participants that the SINEX files reported to the Combination Center have to include the elements of the normal equation system for the positions of the radio sources. So far, this is done routinely only by three IVS ACs but others will follow step by step. Investigations are being carried out to determine how this affects the combination and what benefits can be drawn from this additional information in the normal equation systems.

At present, the combination product is still dominated by input from the Calc/Solve software. For good combination products it is, however, important that results from many different software packages be contributed. If the same analysis software is used, it is important that the analyses are independent and that the analysts create their solutions with their own approach. The IVS Analysis Coordinator has, therefore, established a new template for the analysis description that accompanies the solutions. This template gives a deeper insight into the genuine nature of each contribution.

Further details of radio telescopes have been collected in the antenna information file under <http://vlbi.geod.uni-bonn.de/IVS-AC/Conventions>. The background of the thermal expansion models is described in [4].

## 3. Personnel

Table 1. Personnel at the IVS Analysis Coordinator's office

Axel Nothnagel	+49-228-733574	nothnagel@uni-bonn.de
Thomas Artz	+49-228-733563	thomas.artz@uni-bonn.de

## References

- [1] T. Artz, L. Bernhard, A. Nothnagel, P. Steigenberger, and S. Tesmer (2011). Methodology for the combination of sub-daily Earth rotation from GPS and VLBI observations. *J Geod.* DOI: 10.1007/s00190-011-0512-9.
- [2] G. Chen, and T.A. Herring (1997) Effects of atmospheric azimuthal asymmetry on the analysis of space geodetic data. *J Geophys Res*, Vol. 102, No. B9, pp. 20489-20502, doi: 10.1029/97JB01739
- [3] D. S. MacMillan (1995) Atmospheric gradients from very long baseline interferometry observations. *Geoph Res Letters*, Vol. 22, No. 9, pp. 1041-1044, doi: 10.1029/95GL00887
- [4] Nothnagel A. (2009) Conventions on thermal expansion modelling of radio telescopes for geodetic and astrometric VLBI. *J. Geod* 83(8):787–792, doi:10.1007/s00190-008-0284-z



- [5] IERS Conventions (2010) Gérard Petit and Brian Luzum (eds.). (IERS Technical Note 36) Verlag des Bundesamts für Kartographie und Geodäsie, Frankfurt am Main, 2010. ISBN 3-89888-989-6

# Network Coordinator Report

*Ed Himwich*

## Abstract

A brief report on network performance is presented. Most of network operations went well. Some positive developments are identified. There were a few significant problems, mostly with antennas and receivers. New antennas in Australia and New Zealand started observing. New antennas are under development in the USA. There are prospects for Korea, India, and Saudi Arabia to start contributing to IVS. Other activities of the Network Coordinator are summarized.

## 1. Network Performance

The overall network performance was for the most part good. As occurred last year, this year's report does not include the usual detailed assessment of overall network performance (but we hope to include it again next year). However, the usual average single station loss of 10-20% probably occurred again this year.

One of the positive developments this year is the increased use of e-transfer with data from Ny-Ålesund, Fortaleza, AuScope, and Warkworth now being largely e-transferred. This speeds data transfer and reduces shipping costs. Another positive development is that Mark 5B recorders were installed at several stations. This improves correlator efficiency. A third development is that digital back-ends are starting to be used at more stations for operations. The DBBC developed by the EVN is being used at Hobart, Katherine, Yarragadee, and Warkworth (which is another positive development—the latter three stations just started observing this year). The Haystack/NRAO-developed RDBE is nearing readiness for observations and is expected to start being used in 2012.

Overall, while the network operated well for the most part, there are a few notable issues (in alphabetical order), while some situations improved from the previous year:

- Badary, Svetloe, and Zelenchukskaya had intermittent antenna problems that caused occasional data losses.
- Fortaleza started observing again after being off the air for more than a year. Its SEFDs are now a little higher than before. This may be related to increases in local RFI.
- Hobart, Katherine, and Yarragadee have timing issues with the DBBC back-ends. These cause occasional clock breaks and data gaps when they occur. The manufacturer is investigating this issue.
- Kokee Park's damaged gearbox was repaired and was re-installed. This improved the antenna's pointing and its SEFDs but did not return them to their normal levels. There are still problems with both azimuth gearboxes that will need to be repaired.
- Matera repaired its X-band cryogenic system.
- The receiver at Medicina warmed up in November 2011. It is not clear when it will be repaired.
- Noto is repairing its bearing and is expected to return to operations in the spring of 2012.
- Ny-Ålesund has had higher than normal SEFDs since about May 2010. The cause of this was found and repaired.

- Ny-Ålesund's receiver communications has failed. A back-up system is being used to control the noise diode for system temperature measurements until the receiver can be repaired. Otherwise this is not currently impacting operations.
- TIGO has shown higher than normal SEFDs for several years. There has been no success in resolving this issue.

## 2. New Stations

There are prospects for new stations on several fronts. These include (in approximate order of how soon they will start regular observations):

- At Wettzell in Germany, construction of the new Twin Telescope Wettzell (TTW) for VLBI2010 is underway.
- At GSFC in the USA, a new 12-m antenna has been erected and is undergoing testing. While this antenna is primarily for use in the development of the VLBI2010 systems, it is expected that it will eventually join the network for regular observing.
- At Arecibo in Puerto Rico a new 12-m antenna has been erected and is expected to be used for geodetic observing.
- In Spain/Portugal, the RAEGE (Atlantic Network of Geodynamical and Space Stations) project aims to establish a network of four fundamental geodetic stations including radio telescopes that will fulfill the VLBI2010 specifications: Yebes (1), Canary Islands (1), and Azores (2).
- In Norway, the Norwegian Mapping Authority (NMA) has received initial funding for a project to establish a fundamental station at Ny-Ålesund, which will include a twin telescope of the Wettzell type.
- Onsala has applied for funds for a twin telescope system.
- In Russia, an effort is underway to get 12-m VLBI2010 antennas at some of the QUASAR network sites.
- Korea is planning to build one antenna primarily for geodesy (Korea VLBI system for Geodesy, KVG) at Sejong. There is also interest in geodetic use of the Korean VLBI Network (KVN), which will consist of three stations intended primarily for astronomy.
- There is interest in India in building a network of four telescopes that would be useful for geodesy.
- Saudi Arabia is investigating having a combined geodetic observatory, which would presumably include a VLBI antenna.
- Colombia is investigating having a combined geodetic observatory, which would presumably include a VLBI antenna.

Many of these antennas may become available for use in the next few years. Efforts are being made to ensure that these antennas will be compatible with VLBI2010.

### 3. Network Coordination Activities

Network coordination involved dealing with various network and data issues. These included:

- Reviewing all experiment “ops” messages, correlator reports, and analysis reports for problems and working with stations to resolve them
- Responding to requests from stations for assistance
- Identifying network station issues and working with the Coordinating Center and stations to get them resolved. This year these included:
  - Dealing with Mark 5 recording problems
  - Adjusting procedures for correct monitoring of Mark 5 timing
  - Implementing strong passwords for Mark 5 systems
  - Identifying incorrect resistors on Mark 5 motherboards
  - Preparing Mark 5 modules for use and correcting VSN problems
  - Checking Mark 5 modules for correct alignment
  - Maintaining FS PC kernel
- Planning for possible USA government shutdowns and providing alternate servers for operational data and messages
- Collecting information for RFI protection of sites
- Participating in development of the new VEX2 schedule file standard
- Helping to coordinate Mark 5B transitions at Kokee, Ny-Ålesund, TIGO, Matera, and HartRAO
- Developing a database of Mark 5 recorder version information to help identify station capabilities and which stations need upgrades to be compliant
- Assisting with Warkworth antenna calibration
- Preparations and support for CONT11, including:
  - Preparing plans for handling cable wrap issues at schedule change and break times. These can be avoided in the future if schedules are built continuously across day changes and if the tag-along observations during station breaks are built into the original schedule instead of being added afterwards.
  - Identifying stations unable to support SATA modules and developing work-arounds so all scheduled data can be recorded on available modules.
  - Preparing station test procedures and reviewing results from stations.
  - Assisting with problems during experiments.
- Updating RDV experiment VEX files to allow proper operation with the VLBA correlator, updating the notes file to reflect equipment set-up at different stations, and encouraging timely shipping of data.
- Installing software to support a MET3 instrument at Westford.

#### 4. Future Activities

Network coordination activities are expected to continue next year. The activities will largely be a continuation of the previous year's activities:

- Reviewing all experiment “ops” messages, correlator reports, and analysis reports for problems and working with stations to resolve them
- Responding to requests from stations for assistance
- Identifying network station issues and working with the Coordinating Center and the stations to get them resolved.
- Updating Network Station configuration files.
- Other activities as needed.

# IVS Technology Coordinator Report

*Alan Whitney*

## Abstract

The efforts of the Technology Coordinator in 2011 include the following areas: 1) support of work to implement the new VLBI2010 system, 2) e-VLBI development, 3) continuing development of global VLBI standards, 4) DiFX software correlator for geodetic-VLBI, and 5) creation of a new VLBI technical resources webpage. We will briefly describe each of these activities.

## 1. VLBI2010 Progress

Progress continues towards the goal of a next-generation VLBI2010 system. Much more detailed information about VLBI2010 development is presented elsewhere in this report; here we briefly report some of the highlights:

### 1.1. Development of the VLBI2010 Broadband System

The VLBI2010 system continues to develop at several locations:

1. A pair of VLBI2010 13-m ‘twin-telescopes’ has been installed at Wettzell and is currently under test. RMS surface accuracy is better than 60 micrometers, and the antenna and subreflector are aligned. A tri-band feed will be installed soon, followed by measurements of G/T and pointing tests. A new broadband “Eleven” feed and accompanying receiver and recording systems will be installed in the latter half of 2012.
2. Development of firmware for the FILA10G board for the dBBC continues at MPIfR and Metsahovi. This board is installed in the dBBC, developed by Gino Tuccari, to support bi-directional data-format conversions between VSI-H data format and 10GigE VDIF format.
3. The broadband ‘QRFH’ broadband feed from Caltech has been successfully tested on the VLBI2010 prototype antenna at NASA/GGAO and will soon also be installed on the Westford antenna. Experimental results for beam patterns and efficiencies closely match theoretical predictions. The QRFH feed can be easily re-designed to accommodate a wide variety of antenna geometries.
4. RDBE development continues at Haystack Observatory: The current working version accepts two 512 MHz IFs, channelizes each into fifteen adjacent 32 MHz-wide channels using polyphase filter band (PFB) technology; the user can choose any 16 of these channels to be sent to a 10GigE data link at an aggregate rate of 2 Gbps, which is then recorded on a Mark 5C data system in Mark 5B+ data format. A new ‘quad-band’ version under development will accept up to four 512 MHz IFs, for an aggregate output rate of 4 Gbps. Support for Tsys calibration has been completed and has been verified by tests at NRAO. A comprehensive set of tests comparing the RDBE performance against an exact software model has been highly successful, giving considerable confidence in its proper function.
5. Mark 5C VLBI data system: Mark 5C is now used routinely at 2 Gbps to a single 8-disk module and will enter service at 4 Gbps in early 2012. A 16 Gbps COTS-based Mark 6 system

is under development at Haystack Observatory; a successful 16 Gbps VLBI experiment using an early Mark 6 development system was conducted in November 2011. The Mark 6 is projected to enter service in mid/late 2012.

6. A number of VLBI2010 data-taking sessions between Westford and NASA/GSFC were undertaken during 2011. Most were recorded onto four Mark 5C units at each station using RDBE backend units as data sources, at an aggregate data rate of 8 Gbps/station. More of the processing of VLBI2010 data continues to be moved from the Mark IV correlator to the DiFX correlator at Haystack Observatory.
7. DiFX correlators at MPI, Haystack Observatory, and U.S. Naval Observatory continue to be developed and used for processing geodetic-VLBI data.

## 2. e-VLBI Development

### 2.1. Continuing Expansion and Development of Routine e-VLBI Data Transfers

MPI continues regular e-VLBI transfers of data for which the Bonn correlator is the correlation target. This includes data from Japan, Onsala, Ny-Ålesund, and Wettzell. All data recorded on K5 system at Tsukuba and Kashima are transferred either to MPI or Haystack depending on the target correlator. Syowa K5 data are physically shipped to Japan and electronically transferred to Haystack or MPI. UT1 Intensive data from Wettzell, Japan, and Ny-Ålesund are transferred to either MPI or the Washington correlator.

The Kokee station network connection is being upgraded from 100 Mbps to ~600 Mbps to enhance turnaround for daily UT1 observations. Haystack Observatory has recently upgraded its network connection to 10 Gbps.

### 2.2. 10th International e-VLBI Workshop Held at South Africa

Participants in the 10th International e-VLBI Workshop (13-16 November 2011) were hosted by our South African colleagues at a beautiful and remote conference several kilometers from the Hartebeesthoek Radio Astronomy Observatory. The workshop was attended by 55 participants from 19 countries, including five countries in Africa.

The theme of the meeting was “Towards Global Real-Time e-VLBI”. Within this context, e-VLBI has a lot to offer as a pathfinder technology for the proposed SKA telescope, and the presentations from both the e-VLBI and the SKA communities made for a particularly interesting forum. The workshop was three days in duration, with the first two days dedicated to scientific and technical presentations. The third day we were transported to the HartRAO observatory for tours and more presentations, focusing heavily on establishing VLBI on the greater African continent. A most enjoyable and useful meeting for all!

Presentations from the workshop are available on-line at <http://www.hartrao.ac.za/e-vlbi2011/e-vlbi2011.html>.

The 11th International e-VLBI Workshop will be held at MIT Haystack Observatory in Q3 2011.



Figure 1. Attendees of the 2011 International e-VLBI Workshop held at Amanzingwe Conference Center, South Africa.

### 3. Global VLBI Standards

#### 3.1. VLBI Standards Website Continues to Expand

<http://www.vlbi.org> has been established as a one-stop shop for access to global VLBI standards. These include VEX, VSI-H, VSI-S, VDIF, and standardized VLBI file-naming conventions, plus a brand new VLBI technical resources page. As new standards and technical VLBI resources emerge, they will be included in this website.

#### 3.2. VDIF Data Format

Adoption of the VLBI Data Interchange Format (VDIF), ratified in 2008 at the Madrid e-VLBI workshop, continues to expand. The VLBI2010 project has adopted VDIF as the standard data format, and work is proceeding to fully implement it. Several other data systems now in development are also supporting the VDIF format, and VDIF is now moving strongly into the astronomical world as well. Broad adoption of VDIF across various VLBI disciplines will allow for more standardization and inter-operational capabilities that will benefit all of VLBI.

A VDIF2 data format is nearing completion to meet new demands, including the accommodation of arbitrary sample rates, including those that do not have an integral number of samples in a single second. Such ‘non-standard’ sample rates are being designed into some of the SKA-related systems that would like to participate in global VLBI. The new VDIF2 standard will also relax the constraint of an integral number of filled data packets per second and allow much more flexibility in the choice of packet lengths. This work should be completed by mid-2012.

#### 3.3. VTP

A VLBI Transport Protocol (VTP) Task Force, led by Chris Phillips of ATNF, has developed a proposed standard which is now under review and is expected to be ratified early in 2012.

#### 3.4. VEX2 Task Force Continues Work

The VEX file format is a standardized method to prescribe a complete description of a VLBI experiment, including setup, scheduling, data-taking and correlation, independent of any particular VLBI data-acquisition system or correlator. VEX has gained broad acceptance and is used to



support a large fraction of global VLBI observations, but it needs updating as new technologies and equipment become available. The VEX2 Task Force was created in late 2009 to undertake this job. The members of the VEX2 Task Force are Walter Brisken (NRAO, chair), Ed Himwich (NASA/GSFC), Mark Kettenis (JIVE), Cormac Reynolds (Curtin University), and Alan Whitney (MIT Haystack). This group continues working to craft the needed VEX updates and to incorporate them into several VLBI-support software packages. Again, the target for completion of this work is sometime in 2012.

#### **4. DiFX Software Correlator for Geodetic VLBI**

The so-called DiFX software correlator was originally developed at Swinburne University in Australia by Adam Deller, primarily for astronomical VLBI use. The development of an economical and powerful software correlator, a dream less than a decade ago, has been made possible by the relentless march of Moore's Law to provide powerful inexpensive clustered PCs with high-speed data interconnections that can distribute and correlate VLBI data in an efficient manner. Since the original DiFX development several years ago, the use of the DiFX correlator has spread, and a global DiFX user group has been formed to coordinate continued improvements and additions. Several institutions that support geodetic-VLBI correlation processing now have DiFX correlators (MPIfR, USNO, Haystack Observatory) and have been working to augment the core DiFX software to meet the needs of geodetic-VLBI. This includes the integration of much of the Mark IV-correlator software involving data-management, output data formats, fringe finding and delay estimates, and editing/quality-assurance software. In addition, a substantial amount of work has been done to integrate accurate multi-tone phase-calibration processing into the DiFX correlator, a task that is often not important for astronomical VLBI.

Progress towards developing the necessary additions and improvements to DiFX for geodetic VLBI has been rapid, allowing the DiFX correlator to take over the job of current hardware correlators. MPIfR closed its Mark IV hardware correlator at the end of CY2010. Haystack Observatory is planning to phase out its Mark IV correlator by the end of 2011, with USNO likely to follow soon thereafter.

#### **5. VLBI Technical Resources Web Page**

A new webpage with links to many on-line VLBI technical resources is now available at <http://vlbi.org/resources.html>. Presently 15 institutions worldwide have contributed to this webpage, and more are expected. If you are looking for technical information on a particular VLBI system or subsystem, check here first!



# Network Stations

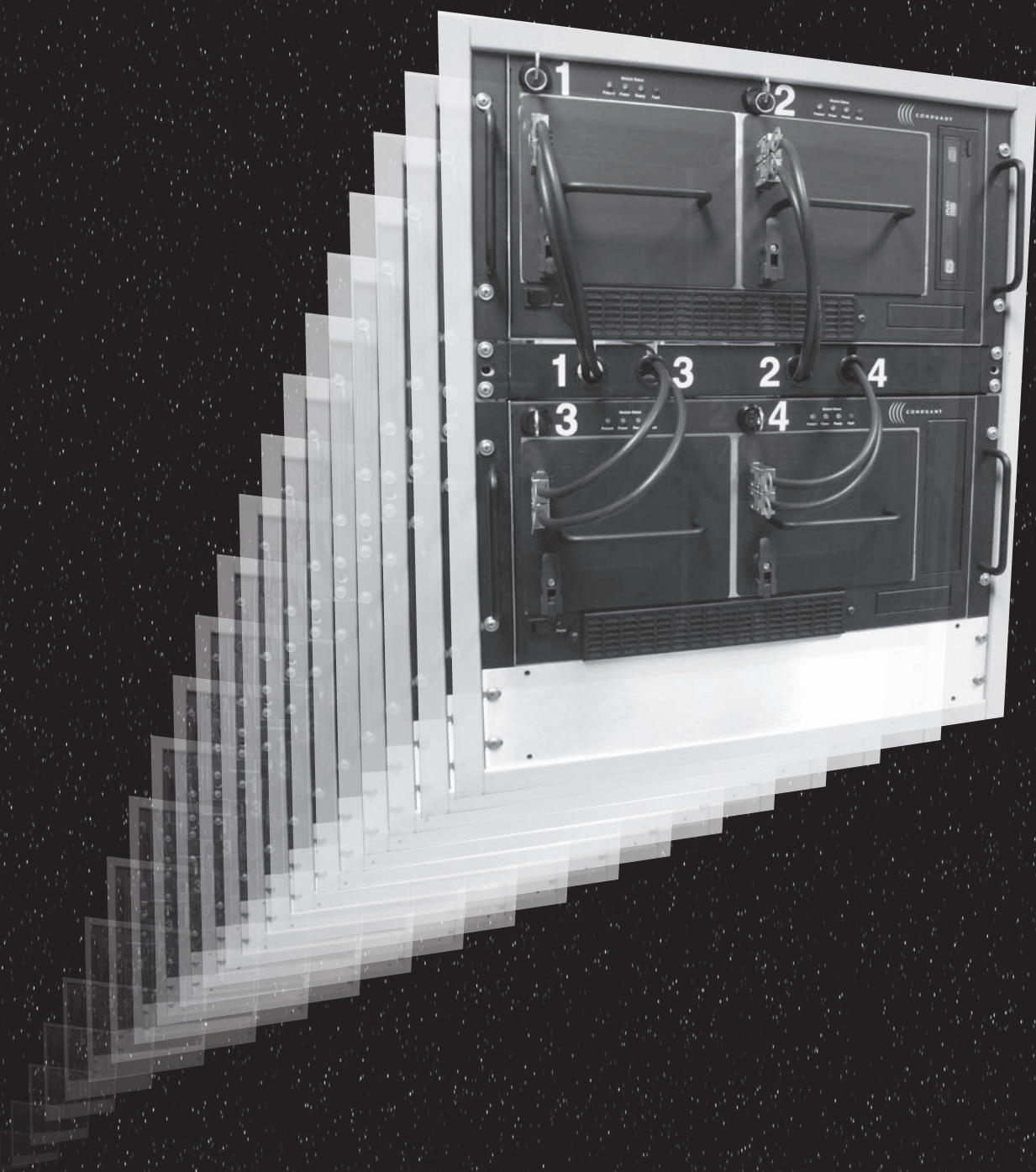

# Network Stations



# Badary Radio Astronomical Observatory

*Sergey Smolentsev, Valery Olifirov*

## Abstract

This report provides information about the Badary network station: general information, facilities, staff, present status, and outlook.

## 1. General Information

The Badary Radio Astronomical Observatory (Figure 1) was founded by the Institute of Applied Astronomy (IAA) as one of three stations of the Russian VLBI network QUASAR [1]. The sponsoring organization of the project is the Russian Academy of Sciences (RAS). The Badary Radio Astronomical Observatory is situated in the Republic Buryatia (East Siberia) about 130 km east of Baikal Lake (see Table 1). The geographic location of the observatory is shown on the IAA RAS Web site (<http://www.ipa.nw.ru/PAGE/rusipa.htm>). The basic instruments of the observatory are a 32-m radio telescope equipped with special technical systems for VLBI observations, GPS/GLONASS/Galileo receivers, a DORIS antenna, and an SLR system installed in 2011.



Figure 1. Badary observatory.

Table 1. Badary Observatory location and address.

Longitude	102°14'
Latitude	51°46'
Badary Observatory	
Republic Buryatia	
671021, Russia	
<code>oper@badary.ipa.stbur.ru</code>	

## 2. Technical Staff

Vladimir Shpilevsky — observatory chief,  
 Nicolay Mutovin — FS, pointing system control,  
 Roman Sergeev — main engineer,  
 Roman Kuptsov — main engineer.

## 3. Technical and Scientific Information

Characteristics of the radio telescope are presented in Table 2. The electrical part of the gear and pointing system of the radio telescope was upgraded in 2008 — 2010. A new DAS R1002M designed at the IAA [2, 3] has been used in all kinds of VLBI observational programs since October 2011.

Table 2. Technical parameters of the radio telescope.

Year of construction	2005
Mount	AZEL
Azimuth range	$\pm 270^\circ$ (from south)
Elevation range	from $-5^\circ$ to $95^\circ$
Maximum azimuth	
- velocity	$1.5^\circ/\text{s}$
- tracking velocity	$1.5'/\text{s}$
- acceleration	$0.2^\circ/\text{s}^2$
Maximum elevation	
- velocity	$0.8^\circ/\text{s}$
- tracking velocity	$1.0'/\text{s}$
- acceleration	$0.2^\circ/\text{s}^2$
Pointing accuracy	better than $10''$
Configuration	Cassegrain (with asymmetrical subreflector)
Main reflector diameter	32 m
Subreflector diameter	4 m
Focal length	11.4 m
Main reflector shape	quasi-paraboloid
Subreflector shape	quasi-hyperboloid
Main reflector surface accuracy	$\pm 0.5$ mm
Frequency range	1.4–22 GHz
Axis offset	$2.5 \pm 0.5$ mm

#### 4. Co-location of VLBI, GPS/GLONASS, DORIS and SLR System

The Topcon GPS/GLONASS/Galileo receiver with automatic meteorological station WXT-510 was tested and put into operation (Figure 2).



Figure 2. Topcon GPS/GLONASS/Galileo receiver at the Badary observatory.

The SLR system “Sazhen-TM” (Figure 3) was mounted in July 2011. The “Sazhen-TM” SLR system was manufactured by Open Joint-stock Research-and-Production Corporation “Precision Systems and Instruments”. Technical parameters of the system are presented in Table 3.



Figure 3. “Sazhen-TM” SLR system at Badary observatory.

Table 3. Technical parameters of the SLR system “Sazhen-TM”.

Ranging distance, day	400-6000 km
Ranging distance, night	400-23000 km
Aperture	25 cm
Wavelength	532 nm
Beam divergence	12''
Laser pulse frequency	300 Hz
Pulse energy	2.5 mJ
Mass	170 kg
Normal points precision	1 cm
Angular precision	1-2''

## 5. Current Status and Activities

Badary observatory participates in IVS and domestic VLBI observational programs. During 2011 Badary station participated in 44 diurnal IVS sessions — IVS-R1, IVS-R4, IVS-T2, EURO, and IVS-CONT11.

Badary participated in 49 diurnal sessions in the frame of the domestic Ru-E program for determination of all Earth orientation parameters, and in 55 one-hour Ru-U sessions for obtaining Universal Time using e-VLBI data transfer.

## 6. Outlook

Our plans for the coming year are the following:

- To participate in IVS observations
- To carry out domestic observational programs for obtaining Universal Time with e-VLBI data transfer and Earth orientation parameters once a week
- To carry out SLR observations of geodetic and navigation satellites
- To participate in EVN and RADIOASTRON observational sessions
- To continue geodetic monitoring of the antenna parameters.

## References

- [1] Finkelstein A., Ipatov A., Smolentsev S. The Network “Quasar”: 2008 — 2011 // “Measuring the future”, Proc. of the Fifth IVS General Meeting, A. Finkelstein, D. Behrend (eds.), St. Petersburg, “Nauka”, 2008. pp. 39–46.
- [2] Grenkov S. A., Nosov E. V., Fedotov L. V., Koltsov N. E. A Digital Radio Interferometric Signal Conversion System // Instruments and Experimental Techniques, 2010. Vol. 53, No. 5. pp. 675–681.
- [3] Nosov E. Next-Generation DAS for the Russian VLBI-Network. // 20th EVGA Meeting. MPIfR, Bonn. 2011. pp. 41–43.



# Fortaleza Station Report for 2011

*Pierre Kaufmann, A. Macílio Pereira de Lucena, Adeildo Sombra da Silva*

## Abstract

This is a brief report about the activities carried out at the Fortaleza geodetic VLBI station (ROEN: Rádio Observatório Espacial do Nordeste), located in Eusébio, CE, Brazil, during the period from January until December 2011. The observing activities were resumed in May after the major maintenance that comprised the azimuth bearing replacement. The total observational experiments consisted of 73 VLBI sessions and continuous GPS monitoring recordings. Fortaleza station participated in the CONT11 campaign. Around 90% of the VLBI data has been transferred to the correlators through a high speed network.

## 1. General Information

The Rádio Observatório Espacial do Nordeste, ROEN, located at INPE facilities in Eusébio, nearly 30 km east of Fortaleza, Ceará State, Brazil, began operations in 1993. Geodetic VLBI and GPS observations are carried out regularly, as contributions to international programs and networks. ROEN is part of the Brazilian space geodesy program, which was initially conducted by CRAAE (a consortium of the Brazilian institutions Mackenzie, INPE, USP, and UNICAMP) in the early 1990s. The program began with antenna and instrumental facility installations, with activities sponsored by the U.S. agency NOAA and the Brazilian Ministry of Science and Technology's FINEP agency. ROEN is currently coordinated by CRAAM, Center of Radio Astronomy and Astrophysics, Engineering School, Mackenzie Presbyterian University, São Paulo, in agreement with the Brazilian National Space Research Institute, INPE. The activities were later carried out under an Agreement of Cooperation signed between NASA—representing research interests of NOAA and USNO—and the Brazilian Space Agency, AEB. This Agreement has been extended until 2021. Under the auspices of this NASA-AEB Agreement, contracts have been signed between NASA and CRAAM, Mackenzie Presbyterian Institute and University to partially support the activities at ROEN. The present contract holds until 2014. The counterpart of the operational costs, staff, and support of infrastructure are provided by INPE and by Mackenzie.

## 2. Main Instruments

The largest instrument at ROEN is the 14.2-m radio telescope, on an alt-azimuth positioner. It is operated at S- and X-bands, using cryogenic radiometers. The system is controlled by the Field System, Version 9.10.4. Observations are recorded with a Mark 5 system. One Sigma-Tau hydrogen maser clock standard is operated at ROEN. GPS monitoring is performed within a cooperative program with NOAA (USA). There is a Leica System 1200 installed at the station that operates continuously. The collected data are provided to the NOAA/IGS center and to the Brazilian IBGE center. ROEN has all basic infrastructures for mechanical, electrical, and electronic maintenance of the facilities.



Figure 1. Receiver box being removed for maintenance.

### 3. Staff

The Brazilian space geodesy program is coordinated by one of the authors (PK), who is Brazil's AEB representative in the NASA-AEB Agreement. The coordination receives support from the São Paulo office at CRAAM/Instituto and Universidade Presbiteriana Mackenzie, with administrative support given by Valdomiro S. Pereira and Lucíola Russo. The Fortaleza Station facilities and geodetic VLBI and GPS operations are managed on site by Dr. A. M. P. de Lucena (CRAAE/INPE), assisted by Eng. Adeildo Sombra da Silva (CRAAE/Mackenzie), and the technicians Avicena Filho (CRAAE/INPE) and Karlos Daniel Menezes (CRAAE/Mackenzie).

## 4. Current Status and Activities

### 4.1. VLBI Observations

In the year 2011, Fortaleza carried out geodetic VLBI experiments as listed in Table 1.

Table 1. 2011 session participation.

Experiment	Number of Sessions
IVS-R1	15
IVS-R4	27
IVS-T2	02
IVS-R&D	02
IVS-RDV	04
IVS-CRF	02
IVS-CONT11	15
IVS-CRMS	01
IVS-OHIG	03

## 4.2. Operational and Maintenance Activities

The summary of activities performed in the period is listed below:

- 1) Supervision of azimuth bearing replacement and antenna painting service;
- 2) Installation of the new cryogenic system;
- 3) Re-installation of the receiver box;
- 4) Repair and maintenance of the following equipment: shaft encoder, FS computer, temperature controller and IF distributor, Mark IV formatter;
- 5) Maintenance and adjustment of DC azimuth and elevation motors;
- 6) Re-making of the antenna pointing model;
- 7) Tests of the antenna, receiver electronics, data acquisition and recording systems for the CONT11 campaign;
- 8) Installation and tests of the Mark IV decoder;
- 9) Operation and maintenance of geodetic GPS (NOAA within the scope of NASA contract);
- 10) Operation and maintenance of power supply equipment at the observatory (main and diesel driven standby);
- 11) Maintenance of the Web site (<http://www.roen.inpe.br>) and the local server computer.

## 4.3. GPS Operations

The IGS network GPS receiver operated regularly at all times during 2011. Data were collected and uploaded to an IGS/NOAA computer.

## 5. Future Plans

Plans for the immediate future consist of the continuation of geodetic VLBI regular observations and the support of GPS receiver operations. Further progress is expected to expand data transmission via high speed national and international networks.

## Acknowledgements

The activities have received partial support from NASA, within an agreement with the Brazilian Space Agency (AEB) and a NASA contract with Mackenzie. They are part of an agreement between Mackenzie and INPE.

# Goddard Geophysical and Astronomical Observatory

*Ricardo Figueroa, Wendy Avelar*

## Abstract

This report summarizes the technical parameters and the technical staff of the VLBI system at the fundamental station GGAO. It also gives an overview about the VLBI activities during the report year.

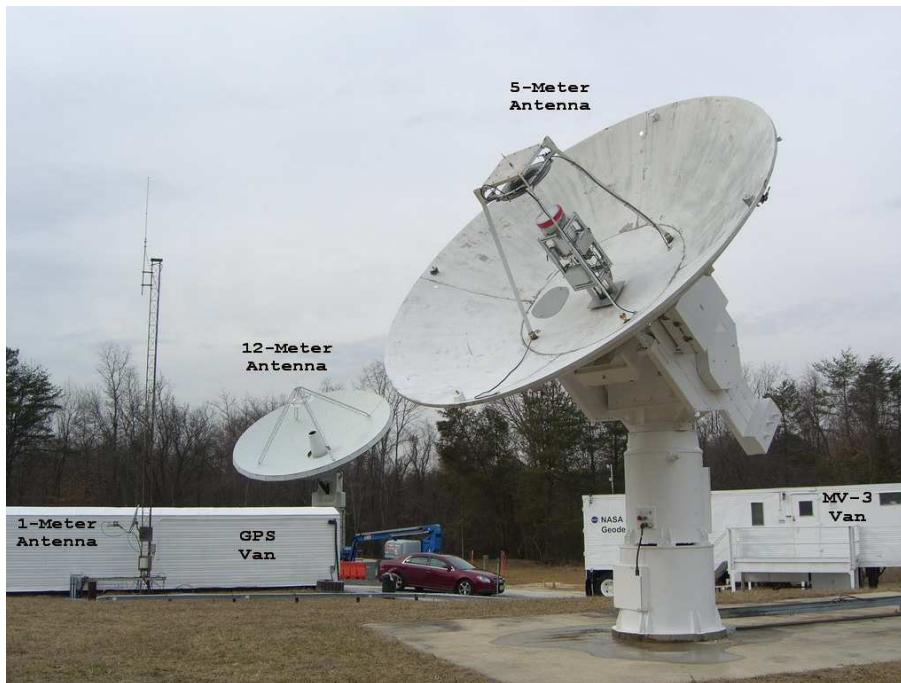

Figure 1. Goddard Geophysical and Astronomical Observatory.

## 1. GGAO at Goddard

The Goddard Geophysical and Astronomical Observatory (GGAO) consists of a 5-meter radio telescope for VLBI, a new 12-meter radio telescope for VLBI2010 development, a 1-meter reference antenna for microwave holography development, an SLR site that includes MOBLAS-7, the NGSRL development system, and a 48" telescope for developmental two-color Satellite Laser Ranging, a GPS timing and development lab, a DORIS system, meteorological sensors, and a hydrogen maser. In addition, we are a fiducial IGS site with several IGS/IGSX receivers.

GGAO is located on the east coast of the United States in Maryland. It is approximately 15 miles NNE of Washington, D.C. in Greenbelt, Maryland (Table 1).

Table 1. Location and addresses of GGAO at Goddard.

Longitude	76.4935° W
Latitude	39.0118° N
MV3 Code 299.0 Goddard Space Flight Center (GSFC) Greenbelt, Maryland 20771	
<a href="http://cddisa.gsfc.nasa.gov/ggao/vlbi.html">http://cddisa.gsfc.nasa.gov/ggao/vlbi.html</a>	

## 2. Technical Parameters of the VLBI Radio Telescopes at GGAO

The 5-m radio telescope for VLBI (MV3) was originally built as a transportable station; however, it was moved to GGAO in 1991 and has been used as a fixed station. In the winter of 2002 the antenna was taken off its trailer and permanently installed at GGAO.

In October 2010, construction of the new 12-meter VLBI2010 developmental antenna was completed. This antenna features all electric drives and a Cassegrain feed system. Integration of the broadband receiver and the associated sub-systems is underway as a joint effort between ITT Exelis and the MIT Haystack Observatory.

The technical parameters of the radio telescopes are summarized in Table 2.

Table 2. Technical parameters of the radio telescopes at GGAO.

Parameter	5m	12m
Owner and operating agency	NASA	NASA
Year of construction	1982	2010
Diameter of main reflector $d$	5m	12m
Azimuth range	$\pm 270^\circ$	$\pm 270^\circ$
Azimuth velocity	$3^\circ/s$	$5^\circ/s$
Azimuth acceleration	$1^\circ/s^2$	$1^\circ/s^2$
Elevation range	$\pm 90^\circ$	$5 - 88^\circ$
Elevation velocity	$3^\circ/s$	$1.25^\circ/s$ ( <i>Avg.</i> )
Elevation acceleration	$1^\circ/s^2$	$1^\circ/s^2$
Receiver System		
Focus	Cassegrain	Cassegrain
Receive Frequency	2 – 14GHz	2 – 14GHz
$T_{sys}$	100 K	50 K ( <i>Theoretical</i> )
Bandwidth	512MHz, 4 bands	512MHz, 4 bands
$G/T$	26 dB/K	43 dB/K
VLBI terminal type	VLBI2010	VLBI2010
Recording media	Mark 5C	Mark 5C

### 3. Technical Staff of the VLBI Facility at GGAO

GGAO is a NASA R&D and data collection facility. On April 9, 2011 the NENS contract transitioned to the SCNS contract operated by ITT Exelis Information Systems. Wendy Avelar conducts VLBI operations and maintenance at GGAO with the support of Ricardo Figueroa, Katie Pazamickas, and Charles Kodak.

### 4. Status of MV3 at GGAO

MV3 continues on a full time basis to be a major component in the program to demonstrate the feasibility of the VLBI2010 broadband delay concept. Working under the guidance of the MIT Haystack Observatory, MV3 has played a critical role in the advancement of the VLBI2010 project. MV3 is configured with the prototype VLBI2010 broadband receiver originally installed in 2009. The 5-m antenna is primarily used to support the holography effort.

Much of the 2011 activities at GGAO have been focused on the performance testing of the VLBI2010 antenna. There were some other activities worth noting:

- Wideband system testing and characterization of the 5-m antenna.
- Procurement of new test equipment for characterization of the wideband RF hardware.
- Broadband Phase Cal unit was installed and under test on the 12-m antenna.
- Testing of three different feed designs for future Broadband use.
- Elevation creep monitoring and prevention.
- Use of Mark 6 recorders to demonstrate 16 Gigabit per second with Westford.
- QRFH feed installed.
- Antenna efficiency significantly improved by adjustment of subreflector and feed positions.
- System temperature, efficiency, and SEFD exceeded nominal values.
- Proof of concept/value of high frequency optical fiber link.
- Refinement of maintenance procedures/schedules for the antenna system.

The holographic imaging capability, which is being developed by the MIT Haystack Observatory with support from ITT Exelis, was suspended during 2011. Activity will begin early in 2012 in order to understand antenna deformations that could potentially dilute the accuracy of the VLBI2010 system. Initially holographic data collections were performed using the 5-m dish as the antenna to be tested and a 1-m satellite receiving dish as the phase reference. Preliminary results from 2010 data collection show that the imaging technique was able to faithfully reconstruct deformations in the aperture of the primary reflector. These deformations included GPS antennas mounted on the rim of the dish, an RF absorbing block, the offset feed Water Vapor Radiometer (WVR) cover, and the subreflector in the center of the primary as shown in Figure 2.

### 5. Outlook

GGAO will continue to support VLBI2010, e-VLBI, and other developmental activities during the upcoming year. Tentative plans for 2012 include:

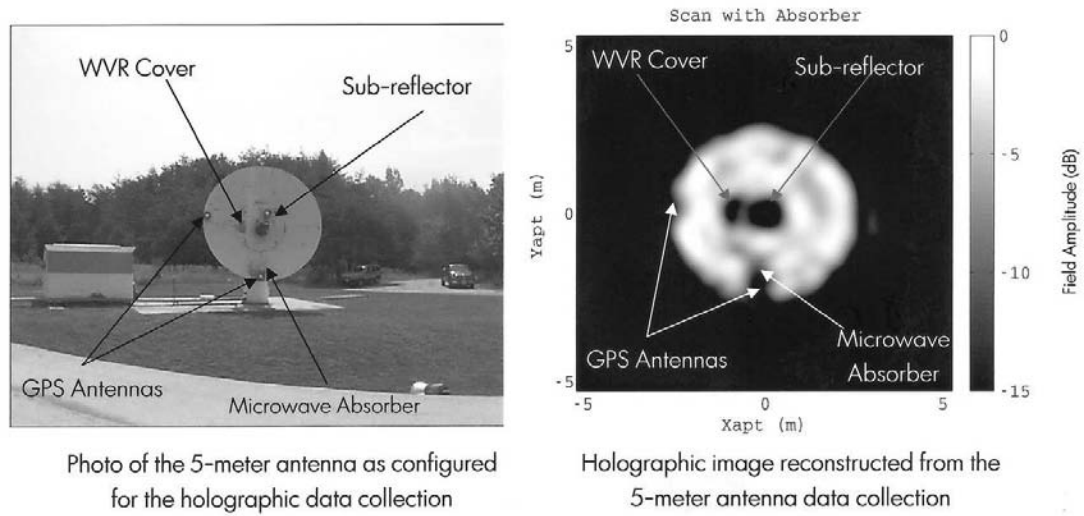

Figure 2. Holographic imaging of the 5-m antenna.

- Install the new VLBI2010 broadband receiver system onto the 12-m antenna.
- Short baseline ties between the 5-m and 12-m antennas.
- Continue testing of the new broadband phase calibrator for the VLBI2010 system.
- Continue holographic imaging of the 5-m and 12-m antennas.
- Continue broadband observations and testing of the VLBI2010 system.
- Continue integration of the RDBEs and Mark 5Cs to replace DBE1s and Mark 5B+s.
- Install newly designed positioner for Dewar and Post-Dewar electronics.
- Test new capabilities of the RDBE digital back end: noise diode switches control and synchronous power measurements for system temperature; use of sign-bit for phase cal monitoring and system diagnosis.
- Implement and use new Mark 6 recorder.
- Use holography to check the position and alignment of the 12-m subreflector.
- Measure the baseline between the 5-m and the 12-m antennas for position tie for the reference frame.
- Continue to monitor elevation creep and evaluate solutions.
- Investigate/resolve problems encountered with cold weather related performance of the 5-m and 12-m elevation axis controller.

# Hartebeesthoek Radio Astronomy Observatory (HartRAO)

*Marisa Nickola, Jonathan Quick, Ludwig Combrinck, Mike Gaylard*

## Abstract

HartRAO provides the only fiducial geodetic site in Africa, and it participates in global networks for VLBI, GNSS, SLR, and DORIS (located at the adjoining South African National Space Agency Earth Observation (SANSA EO)). This report provides an overview of the geodetic VLBI activities and HartRAO's 50th anniversary during 2011.

## 1. Geodetic VLBI at HartRAO

Hartebeesthoek is located 65 kilometers northwest of Johannesburg, just inside the provincial boundary of Gauteng, South Africa. The nearest town, Krugersdorp, is 32 km distant. The telescope is situated in an isolated valley which affords protection from terrestrial radio frequency interference. HartRAO currently uses a 26-meter equatorially mounted Cassegrain radio telescope built by Blaw Knox in 1961. The telescope was part of the NASA deep space tracking network until 1974 when the facility was converted to an astronomical observatory. The telescope is co-located with an ILRS SLR station (MOBLAS-6), an IGS GNSS station (HRAO), and an IDS DORIS station (HBMB) at the adjoining South African National Space Agency Earth Observation (SANSA EO) site. HartRAO became a full member of the EVN on the 11th of May 2011.



Figure 1. The 26-m antenna and 15-m KAT-prototype antenna, IGS GPS antenna, NASA Moblas-6 SLR and LLR under development. (Credit: L. Combrinck)



## 2. Technical Parameters of the 26-m Telescope of HartRAO

Table 1 contains the technical parameters of the HartRAO 26-m radio telescope and the 15-m Karoo Array Telescope (KAT) prototype antenna, while Table 2 contains technical parameters of the HartRAO 26-m radio telescope's receivers. The current data acquisition system consists of a Mark 5 terminal and a Mark 5B recorder.

Table 1. Antenna parameters.

Parameter	HartRAO 26-m	HartRAO 15-m
Owner and operating agency	HartRAO	HartRAO
Year of construction	1961	2007
Radio telescope mount	Offset equatorial	Az-El
Receiving feed	Cassegrain	Prime focus
Diameter of main reflector $d$	25.914 $m$	15 $m$
Focal length $f$	10.886 $m$	7.5 $m$
Focal ratio $f/d$	0.424	0.5
Surface error of reflector (RMS)	0.5 $mm$	$\sim 2.5 mm$
Short wavelength limit	1.3 $cm$	2 $cm$
Pointing resolution	0.001 $^\circ$	0.001 $^\circ$
Pointing repeatability	0.004 $^\circ$	not tested
Slew rate on each axis	HA: 0.5 $^\circ s^{-1}$ Dec: 0.5 $^\circ s^{-1}$	Az: 2 $^\circ s^{-1}$ El: 1 $^\circ s^{-1}$

Table 2. 26-m receiver parameters with dichroic reflector (DR), used for simultaneous S-X VLBI, off or on.

Parameter	X-band	S-band
Feeds	dual CP conical	dual CP conical
Amplifier type	cryo HEMT	cryo HEMT
$T_{sys}$ (DR off) ( $K$ )	60	44
$T_{sys}$ (DR on) ( $K$ )	70	50
$S_{SEFD}$ (DR off) ( $Jy$ )	684	422
$S_{SEFD}$ (DR on) ( $Jy$ )	1330	1350
Point source sensitivity (DR off) ( $Jy/K$ )	11.4	9.6
Point source sensitivity (DR on) ( $Jy/K$ )	19	27
3 dB beamwidth ( $^\circ$ )	0.092	0.332

## 3. Current Status

A bearing replacement before age 50 did not hamper the performance of the HartRAO 26-m radio telescope. Position time series solutions indicate that the repair of the 26-m's south polar bearing did not cause any noticeable shift in the telescope's position. During September 2011, shortly after celebrating its 50th birthday on the 1st of July 2011, the 26-m successfully participated

in the CONT11 campaign, needing to make use of only one of the scheduled maintenance periods. Earlier the data acquisition system was upgraded with a Mark 5 (VSI-4) sampler and the recorder upgraded to Mark 5B, with the first experiment following the upgrade taking place on the 11th of July. Another first was the commencement of e-transfers of geodetic VLBI data starting on the 21st of February 2011 with R1 data destined for the Bonn correlator. Telescope time allocation for geodetic VLBI was increased to 63 24-hour experiments in 2011 to include the CONT11 campaign (Table 3). Table 4 lists the HartRAO station staff who are involved in geodetic VLBI. Jonathan Quick (VLBI friend) provides technical support for the Field System as well as for hardware problems. Further progress was made with the conversion of the 15-m KAT prototype to a geodetic VLBI capable antenna with the new co-axial dual circular polarization S/X (2.3 and 8.4 GHz) prime-focus cryogenic receiver now successfully calibrated in laboratory tests, showing average system temperatures of  $\sim 32\text{K}$  at S and  $\sim 29\text{K}$  at X. In preparation for the installation of the S/X receiver, the original XDM (eXperimental Design Model) multi-feed receiver system “Stargate” and its parallactic rotation stage have been removed from the 15-m’s prime focus, and installation of helium and vacuum lines is in process.

Table 3. Geodetic VLBI experiments HartRAO participated in during 2011.

Experiment	Number of Sessions
R1	26
CONT11	15
CRDS	6
RDV	5
RD	4
OHIG	3
CRF	2
T2	2
Total	63

Table 4. Staff supporting geodetic VLBI at HartRAO.

Name	Function	Program
L. Combrinck	Program Leader	Geodesy
J. Quick	Hardware/ Software	Astronomy
R. Botha	Operator	Geodesy
J. Grobler	Operator	Technical
L. Masongwa	Operator	Technical
R. Myataza	Operator	Technical
M. Nickola	Logistics/ Operations	Geodesy
P.Stronkhorst	Operator	Technical

#### 4. Future Plans

Conversion of the 15-m KAT prototype antenna for use in geodetic VLBI experiments should hopefully be completed during early 2012. Two DBBC back-ends have recently arrived at HartRAO and are undergoing acceptance testing. A spare Mark 5B+ recorder has also been procured with a third recorder (for electronic data shipment) on order. The Lunar Laser Ranger (LLR) housing has been completed, and refurbishment of the telescope and design of other LLR subsystems will proceed during 2012.



Figure 2. 15-m XDM's S/X receiver package looking at sky during noise temperature tests. (Credit K. Jones)



Figure 3. S/X receiver with integral feed to be installed at XDM prime focus. (Credit M. Nickola)



Figure 4. A coin minted in 1961 indicates the year the foundation for the 26-m was laid. (Credit: M. Gaylard)



Figure 5. Mechanical supervisor, André van der Merwe, inspects the LLR telescope and its housing. (Credit: L. Combrinck)

## Acknowledgements

The Space Geodesy Programme is an integrated program, combining VLBI, SLR, and GNSS, and it is active in several collaborative projects with GSFC, JPL, and GFZ (Potsdam) as well as numerous local institutes. Collaboration also includes CNES/GRGS/OCA and the ILRS community in a Lunar Laser Ranger (LLR) project with local support from the University of Pretoria and the National Laser Centre (CSIR), among others. General information as well as news and progress on geodesy and related activities can be found at <http://geodesy.hartrao.ac.za/>.

# AuScope VLBI Project and Hobart 26-m Antenna

*Jim Lovell, John Dickey, Brett Reid, Jamie McCallum, Stas Shabala, Simon Ellingsen*

## Abstract

This is a report on the activities carried out at the three AuScope VLBI observatories and the Hobart 26-m antenna. In 2011 the AuScope 12-m antenna at Hobart (Hb) completed its first full year of operations while the Katherine (Ke) and Yarragadee (Yg) antennas were commissioned and commenced operation. The Hobart 26-m antenna (Ho) continued to make a contribution to IVS, providing overlap with the Hb time series. The Hobart 12-m also participated in the 15-day CONT11 campaign in September. In total the AuScope antennas and the Hobart 26-m observed for 171 antenna days in 2011.

## 1. Introduction

In 2006 the National Collaborative Research Infrastructure Strategy (NCRIS) initiated program 5.13, “Structure and Evolution of the Australian Continent”, which is funded by the Australian Federal Government’s Department of Innovation, Industry, Science and Research (DIISR) and managed by AuScope Ltd. ([www.auscope.org.au](http://www.auscope.org.au)). A major component of this project was the establishment of a national geospatial framework to provide an integrated spatial positioning system spanning the whole continent. Total federal funding for this undertaking is AUD\$15.8M, together with AUD\$21M from universities, state governments and Geoscience Australia. The infrastructure that was funded to achieve this improvement to the geospatial framework included:

- three 12-meter radio telescopes and a software correlator
- approximately 100 GNSS receivers
- an upgrade of existing SLR facilities
- an absolute gravimeter and three tidal gravimeters
- improved computing facilities

## 2. VLBI Facilities

As part of this effort, the University of Tasmania (UTAS) has constructed three new radio telescopes, located near Hobart (Tasmania), Yarragadee (Western Australia), and Katherine (Northern Territory). UTAS is responsible for construction and operation of these new VLBI sites (Figure 1). The AuScope telescopes closely follow the International VLBI Service VLBI2010 specification for the next generation of telescopes for geodesy (Petrachenko et al., 2009) or provide an upgrade path to meet the specification where it is not currently possible to do so.

The new Hobart telescope (Hb) is co-located with the existing 26-m telescope (Ho) to preserve the more than 20 year VLBI time series at the site. Midway between the 26-m and 12-m telescopes is the HOB2 GNSS installation which has been a core site of the International GNSS Service (IGS) since its conception. A hut capable of housing a mobile gravimeter is also co-located on the site. The Yarragadee telescope (Yg) provides a far western point on the continent and is co-located with multiple existing geodetic techniques including SLR, GNSS, DORIS and gravity. The Katherine



Figure 1. The geographical distribution of VLBI and GNSS infrastructure for AuScope. From west to east, the new VLBI stations are at Yarragadee, Katherine, and Hobart. An additional  $\sim 100$  GNSS receivers will be distributed across the continent.

site (Ke) is new and provides a central longitude, northern site. The telescope at Katherine is co-located with a new GNSS site that forms part of the AuScope GNSS network.

Each AuScope VLBI observatory is equipped with a 12.1-m diameter main reflector designed and constructed by COBHAM Satcom, Patriot Products division. The telescope specifications include: 0.3 mm of surface precision (RMS), fast slewing rates (5 deg/s in azimuth and 1.25 deg/s in elevation), and acceleration (1.3 deg/s/s). All three sites are equipped with dual polarization S- and X-band feeds from COBHAM with room temperature receivers, developed at UTAS by Prof. Peter McCulloch. The receiver systems cover 2.2 to 2.4 GHz at S-band and 8.1 to 9.1 GHz at X-band. System Equivalent Flux Densities (SEFDs) are 3500 Jy in both bands. Data digitization and formatting is managed by the Digital Base Band Converter (DBBC) system from HAT-Lab, and data are recorded using the Conduant Mark 5B+ system. Each site is equipped with VCH-1005A Hydrogen maser time and frequency standards from Vremya-CH.

All three observatories were designed and constructed to be remotely controlled and monitored to keep operating costs at a minimum. Operation of the AuScope VLBI array is being carried out from a dedicated operations room on the Sandy Bay campus of the University of Tasmania.

### 3. Staff

Staff at UTAS consist of academics, Prof. John Dickey (director), Dr. Simon Ellingsen, and Prof. Peter McCulloch. Dr. Jim Lovell is Project Manager for the AuScope VLBI project. Dr. Jamie McCallum and Dr. Stas Shabala are Australian Research Council Super-Science Fellows who are carrying out research aimed at improving geodetic VLBI solutions in the southern hemisphere. Mr. Brett Reid is the Observatory Manager whose position is funded by the university. In addition we have an electronics technical officer, Mr. Eric Baynes. For operation of the observatories during geodetic observations we rely heavily on support from astronomy PhD and post graduate students. Logistical and maintenance support at Katherine is provided by Mr. Martin Ephgrave and at Yarragadee by Mr. Vince Noyes and team at the MOBILAS5 SLR station.

### 4. AuScope VLBI Project Status

Construction of the first AuScope telescope at Hobart was completed in 2009 and officially opened at the IVS General Meeting on February 9, 2010. Following a period of commissioning, testing and debugging, the Hobart telescope made its first successful IVS observation in October 2010. Construction and commissioning at the other two sites continued in parallel. Yarragadee made its first successful IVS observation in May 2011, and all three telescopes participated in an IVS observation for the first time on June 16, 2011.

At present, the AuScope VLBI facility has sufficient operational funds for  $\sim 70$  observing days per year, usually consisting of two AuScope telescopes observing as part of the IVS network. The Hobart 26-m antenna will continue to participate in IVS observations at the level of one session per month to provide continuity in the Hobart time series.

### 5. Geodetic VLBI Observations

In 2011 the AuScope and Hobart 26-m antennas participated in 102 IVS sessions for a total of 171 antenna days of observing. This included the Hobart 12-m participating in the 15-day

CONT11 campaign. A summary of the observations is presented in Table 1

Table 1. AuScope and Hobart 26-m antenna participation (number of days) in IVS sessions in 2011.

Session	Antenna			
	Ho	Hb	Ke	Yg
AUSTRAL		2	2	2
CONT11		15		
CRDS		5	4	3
CRF		3		
OHIG	1	2		
R1	11	27	9	8
R4	12	29	11	11
RD		2	1	1
RDV		1		
T2	3	4	1	1
Total	27	90	28	26

## 6. References

Petrachenko, B. et al., 2009, "Design Aspects of the VLBI2010 System. Progress Report of the IVS VLBI2010 Committee.". NASA/TM-2009-214180, June 2009.

# Kashima 34-m Radio Telescope

Ryuichi Ichikawa, Eiji Kawai, Mamoru Sekido

## Abstract

The Kashima 34-m radio telescope has been continuously operated and maintained by the National Institute of Information and Communications Technology (NICT) as a facility of the Kashima Space Research Center (KSRC) in Japan. This brief report summarizes the status of this telescope, the staff, and activities during 2011. In particular, we describe antenna damage due to the  $M_w$  9.0 megaquake which occurred on March 11th, 2011.

## 1. General Information

The Kashima 34-m radio telescope (Figure 1, left) was constructed as a main station of the “Western Pacific VLBI Network Project” in 1988. After that project’s termination, the telescope has been used not only for geodetic experiments but also for astronomy and other purposes [1]. The station is located about 100 km east of Tokyo, Japan and is co-located with the 11-m radio telescope and the International GNSS Service station (KSMV) (Figure 1, right). The station is maintained within the Space-Time Measurement Project of the Space-Time Standards Group, NICT.

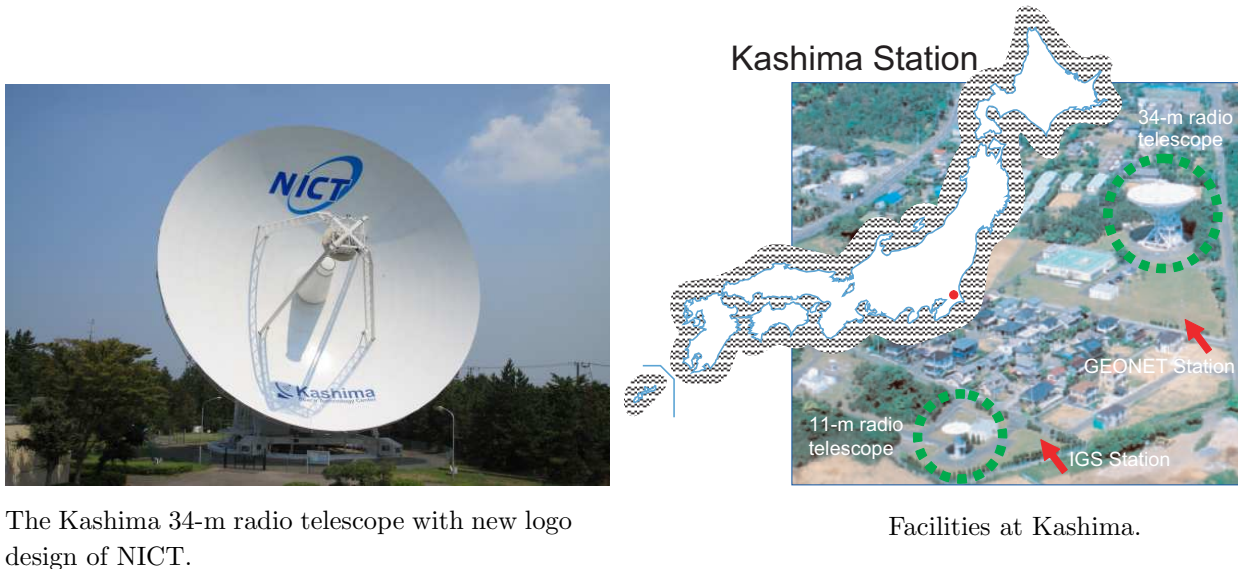

The Kashima 34-m radio telescope with new logo design of NICT.

Facilities at Kashima.

Figure 1. The Kashima Station.

## 2. Component Description

The receiver equipment of the Kashima 34-m radio telescope is summarized in Table 1 and Table 2. In particular the high-temperature superconductor (HTS) band-pass filter is equipped at the S-band receiver for RFI mitigation [3]. We also installed a band-pass filter on July 15, 2008 to cut out signals between 1405 MHz and 1435 MHz for L-band RFI mitigation.



Table 1. Main specifications of the 34-m radio telescope.

Main reflector aperture	34.073 m
Latitude	N 35° 57' 21.78"
Longitude	E 140° 39' 36.32"
Height of AZ/EL intersection above sea level	43.4 m
Height of azimuth rail above sea level	26.6 m
Antenna design	Modified Cassegrain
Mount type	AZ-EL mount
Drive range azimuth	North $\pm 270^\circ$
Drive range elevation	7°-90°
Maximum speed azimuth	0.8°/sec
Maximum speed elevation	0.64°/sec
Maximum operation wind speed	13 m/s
Panel surface accuracy r.m.s.	0.17 mm

Table 2. The receiver specifications of the 34-m radio telescope.

Band	frequency (MHz)	Trx (K)	Tsys (K)	Efficiency	SEFD (Jy)	Polarization
L	1350-1750*	18	45	0.68	200	L/R
S	2193-2350	19	72	0.65	340	L/R
C	4600-5100	100	127	0.70	550	L(R)
X-n	8180-9080*	41	48	0.68	210	L/R
X-wL	8180-9080#	41	67	0.68	300	L/R
X-wH	7860-8360#	-	67	0.68	300	L/R
K	22000-24000	105	141	0.5	850	L(R)
Ka	31700-33700	85	150	0.4	1100	R(L)
Q	42300-44900	180	350	0.3	3500	L(R)

\* : 8 GHz LNA narrow band use. # : 8 GHz LNA wide band use.

\* : Narrow bandwidth filter, 1405 – 1435 MHz, is used generally to mitigate RFI.

### 3. Staff

The engineering and technical staff of the Kashima 34-m radio telescope are listed in Table 3. Dr. Sekido returned to KSRC in March 2011, and he is now continuing the development of the K5 system.

### 4. Current Status and Activities

The  $M_w$  9.0 megaquake hit the 34-m antenna on March 11th, 2011. We suffered from strong ground motion, and a 5.2-m high tsunami attacked the Kashima port as shown in Figure 2. In addition, we were facing serious restrictions due to the Fukushima nuclear accident. Fortunately, we have no staff casualties in KSRC/NICT. Coseismic crustal deformations measured by our GPS station near the 34-m antenna showed movements of up to 749 mm in the horizontal (eastward) and

Table 3. The engineering and technical staff of the Kashima 34-m radio telescope.

Name	Main Responsibilities
KAWAI Eiji	responsible for operations and maintenance
SEKIDO Mamoru	technical development for time and frequency (T&F) transfer
TAKEFUJI Kazuhiro	T&F experiments using VLBI facilities
HASEGAWA Shingo	K5 operation and data transfer
ICHIKAWA Ryuichi	responsible for the project
KONDO Tetsuro	software correlator development and e-VLBI

-245 mm in the vertical. Moreover, post-seismic deformations following the main shock reached values of over 270 mm in the horizontal and about 100 mm in the vertical component as recorded until the end of July.

We carried out an operational repair of the antenna (i.e., repainting of the main dish and rust-proofing of the antenna structure) starting on the first of January, 2011. The repair was supposed to be finished by the end of March. However, the repair was stopped due to the earthquake. The repair was restarted in April, and it was finished at the end of June. After the repair, we investigated earthquake damage carefully. Unfortunately, the gear reducers, the power and helium plumbing, the azimuth track wear strips, and one azimuth wheel were damaged by the strong motion which exceeded 650 gal as recorded around the Kashima region. In 2011, the operation time of our 34-m antenna was only 364 hours in total. About 60% of the operation time was used for earthquake damage investigation. The other facilities at KSRC/NICT (e.g., the main building, the guest room building, and the outreach building) are also partly damaged. Thus, these buildings are currently under repair.

## 5. Future Plans

First, we have to fix damage of the 34-m radio telescope due to the earthquake as soon as possible. Though the damage is severe, we are going to repair them by the end of the next fiscal year. In addition, we have a plan to install new AZ/EL driving units into the antenna in this fiscal year.

## References

- [1] Kawai, E., M. Sekido, R. Ichikawa, Kashima 34-m Radio Telescope, International VLBI Service for Geodesy and Astrometry 2008 Annual Report, NASA/TP-2009-214183, D. Behrend and K. D. Baver (eds.), pp. 114–117, 2008.
- [2] “Koho Kashima (Kashima public relations, [http://city.kashima.ibaraki.jp/20kouhou/data/20110401/0401\\_all\\_ver2.eps](http://city.kashima.ibaraki.jp/20kouhou/data/20110401/0401_all_ver2.eps) (in Japanese))”, No. 393, April 1st, 2011.
- [3] Kawai, E., J. Nakajima, H. Takeuchi, H. Kuboki, T. Kondo, M. Suzuki, K. Saito, RFI mitigation at a 2 GHz band by using a wide-band high-temperature superconductor filter, J. Geod. Soc. Jpn., Vol. 54, No. 1, pp. 31–37, 2008.



Figure 2. Earthquake damage in Kashima city. (a) A tsunami struck the Kashima port and surrounding area [2], (b) train rail bent by powerful ground motion, (c) cargo containers thrown around by the tsunami in Kashima, (d) Kashima port hit by the tsunami, (e) ripple mark of 34-m antenna azimuth rail caused by strong motion, (f) broken road in front of the KSRC/NICT main building (photos (b) and (f) were taken by Dr. Kondo).

# Kashima and Koganei 11-m VLBI Stations

*Mamoru Sekido, Ryuichi Ichikawa*

## Abstract

Two 11-m VLBI antennas at Kashima and Koganei are continuously operated and maintained by the National Institute of Information and Communications Technology (NICT). This brief report summarizes the status of these antennas, the staff, and the activities during 2011.

## 1. Introduction



Figure 1. 11-m VLBI antennas at Kashima (left) and Koganei (right).

Two 11-m VLBI antennas at Kashima and Koganei (Figure 1) used to be stations of the Key Stone Project (KSP) VLBI Network. The network consisted of four VLBI stations at Kashima, Koganei, Miura, and Tateyama (Figure 2). These 11-m antennas and other VLBI facilities at the Miura and Tateyama stations have been transported to the Tomakomai Experimental Forest of the Hokkaido University and to the campus of Gifu University, respectively. As a consequence, two 11-m stations at Kashima and Koganei remain as IVS Network Stations.

The KSP was a research and development project of the National Institute of Information

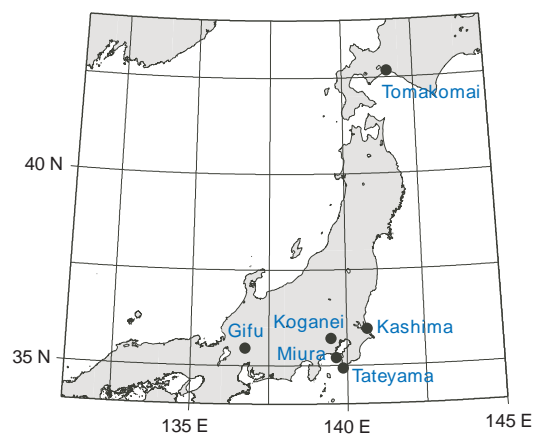

Figure 2. Geographic locations of four KSP VLBI stations and two stations at Tomakomai and Gifu.

and Communications Technology (NICT, formerly Communications Research Laboratory) [1]. After the regular VLBI sessions with the KSP VLBI Network terminated in 2001, the 11-m VLBI stations at Kashima and Koganei have mainly been used for the purposes of technical developments and miscellaneous observations.

## 2. Current Status

The main specifications of the antennas are summarized in Table 1. Both antennas can observe S- and X-band. The original specifications of these antennas were the same. The frequency of the first local oscillator of X-H band at the Kashima 11-m station was changed by 80 MHz, so that the observation frequency range became the same as the range of the Kashima 34-m station. The band-pass filter for S-band was replaced for RFI mitigation at both stations in 2010.

The optical loop-back controlled reference signal transmission system has been installed between the second building of NICT-HQ and the Koganei VLBI station operation building since 2009. That provides the reference signal (5MHz/1PPS) of UTC(NICT) to the Koganei 11-m station [2].

The reference signal (5MHz/1PPS) of the Kashima 11-m station has been provided by the H-maser atomic standard at the Kashima 34-m station via a long distance (about 500 m) co-axial cable. In November 2011, a mobile hydrogen maser atomic time standard was installed at the Kashima 11-m station, and its reference signal became independent from the reference signal of the Kashima 34-m station. A precise temperature control box, which was installed in the Kashima 11-m observation room in 2010, is keeping the temperature inside the box within a few tenths of degrees of Kelvin. Reference signal distribution units are placed inside this box.

Both stations are using phase calibration signal (P-cal) unit of 5-MHz interval instead of 1-MHz interval.

Table 1. The specifications of the KSP 11-m antennas.

		Kashima	Koganei
Antenna Type		Cassegrain type	
Diameter of the Main Reflector		11 m	
Mount Style		Az El mount	
Latitude		N 35° 57' 20.12"	N 35° 42' 38.01"
Longitude		E 140° 39' 26.93"	E 139° 29' 17.10"
Height of Az/El intersection above sea level		62.4 m	125.4 m
Input Frequency (MHz)	S band	2212 ~ 2360	2212 ~ 2360
	X Low band	7700 ~ 8200	7700 ~ 8200
	X High band	8180 ~ 8680	8100 ~ 8600
Local Frequency (MHz)	S band	3000	3000
	X Low band	7200	7200
	X High band	7680	7600

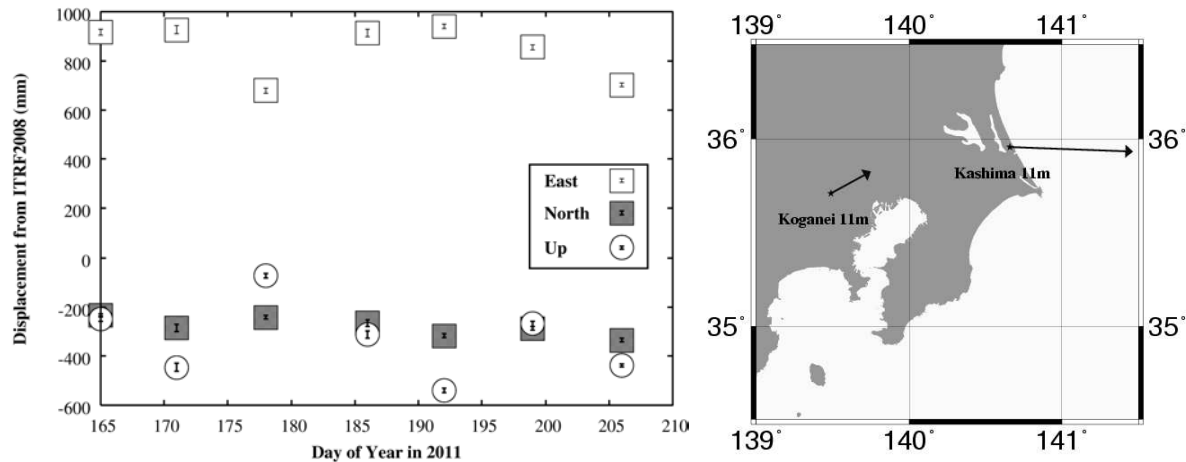

Figure 3. Displacement of the Kashima 11-m station's global coordinates obtained from R1 sessions (left). Horizontal displacement vector of the Kashima 11-m and Koganei 11-m stations derived from the JD1109 session (right).

### 3. Activities in 2011

The Kashima region was widely affected by the big earthquake that occurred on 11 March 2011 in the north east of Japan, although fortunately the Kashima 11-m and Koganei 11-m stations were not seriously damaged. We have performed antenna pointing parameter observations with the Kashima 11-m station several times (8 June, 4 July, 29 August, and 28 December) for monitoring of particular changes of pointing parameters caused by the earthquake and after-shocks. In a comparison of the pointing model parameters with those obtained in 2008, there were permanent changes to the Az-axis tilting angle and the Az-offset parameters in these observations (Figure 4).

Since the earthquake was so big, crustal deformation around the north east area of Japan is still continuing. For the purpose of monitoring the baseline changes on the Kashima — Koganei baseline, a series of VLBI observations have been conducted since 7 May. The time series of the baseline length changes, and a general list of experiments processed by the correlator at Kashima, is indicated in Figure 2 and Table 2, respectively, in the correlator report of Kashima in this volume.

Apart from the VLBI sessions, the Space Weather and Environment Informatics Laboratory of NICT is using the 11-m antenna at Koganei to download data from the STEREO spacecrafts. Two STEREO spacecrafts were launched by NASA in October 2006 to investigate the solar terrestrial environment and to provide 3D images of the Sun and solar storms. The Koganei 11-m antenna

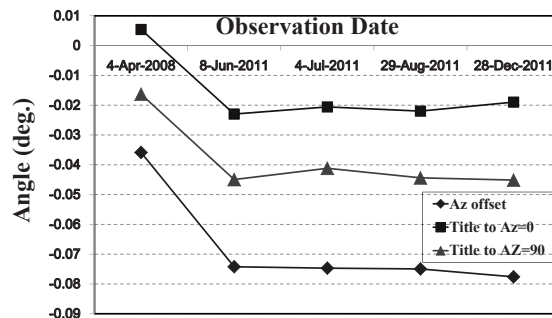

Figure 4. Changes of azimuthal axis tilting and azimuth angle offset were found after the earthquake on 11 March 2011.

is most of the time operated for this purpose, as long as VLBI sessions are not scheduled.

#### 4. Staff Members

The 11-m antenna stations at Kashima and Koganei are operated and maintained by the members of the Space-Time Standards Laboratory at the Kashima Space Technology Center (KSTC) and headquarters of NICT. The staff members of the group are listed in Table 2. The operation and maintenance of the 11-m VLBI station at Koganei is also greatly supported by the Space Weather and Environment Informatics Laboratory and the Space Communication Systems Laboratory at the Koganei Headquarters of NICT.

Table 2. Staff members of the Space-Time Standards Laboratory, KSTC, NICT.

Name	Main Responsibilities
KAWAI Eiji	Antenna Systems
ICHIKAWA Ryuichi	Meteorological Sensors, IGS Receivers
AMAGAI Jun	Antenna System and Timing Systems at Koganei 11-m station
SEKIDO Mamoru	Antenna System, Field System, Calibration and Frequency Standard Systems
HASEGAWA Shingo	Computer System

#### 5. Future Plans

In 2012, we plan to continue VLBI experiments for precise time and frequency transfer and crustal deformation monitoring. In 2012, the Kashima and Koganei 11-m stations will also participate in IVS-T2 sessions.

#### References

- [1] Special issue for the Key Stone Project, J. Commun. Res. Lab., Vol. 46, No. 1, March 1999.
- [2] Fujieda, M., M. Kumagai, S. Nagano, and T. Gotoh UTC(NICT) signal transfer system using optical fibers, IVS NICT-TDC News, No. 31, 17-20, 2010.
- [3] Sekido, M., R. Ichikawa, VLBI Correlators in Kashima, International VLBI Service for Geodesy and Astrometry 2011 Annual Report, this volume, 2012.

# Kokee Park Geophysical Observatory

*Ron Curtis*

## Abstract

This report summarizes the technical parameters and the staff of the VLBI system at Kokee Park on the island of Kauai.

## 1. KPGO

The Kokee Park Geophysical Observatory (KPGO) is located in the Kokee State Park on the island of Kauai in Hawaii at an elevation of 1,100 meters near the Waimea Canyon, often referred to as the Grand Canyon of the Pacific.

Table 1. Location and address of Kokee Park Geophysical Observatory.

Longitude	159.665° W
Latitude	22.126° N
Kokee Park Geophysical Observatory P.O. Box 538 Waimea, Hawaii 96796 USA	

## 2. Technical Parameters of the VLBI System at KPGO

The receiver is of NRAO (Green Bank) design (dual polarization feed using cooled 15 K HEMT amplifiers). The DAR rack and tape drive were supplied through Green Bank. The antenna is of the same design and manufacture as those used at Green Bank and Ny-Ålesund. We presently employ a Mark 5B+ recorder for all of our data recording.

The technical parameters of the radio telescope are summarized in Table 2.

Timing and frequency is provided by a Sigma Tau Maser with a NASA NR Maser providing backup. Monitoring of the station frequency standard performance is provided by a CNS (GPS) Receiver/Computer system. The Sigma Tau performance is also monitored via the IGS Network.

## 3. Staff of the VLBI System at KPGO

The staff at Kokee Park from January 1 through April 8, 2011 consisted of five people employed by Honeywell Technology Solutions, Inc. under the NENS contract to NASA for the operation and maintenance of the observatory. Matt Harms, Chris Coughlin, and Ron Curtis conducted VLBI operations and maintenance. Ben Domingo was responsible for antenna maintenance, with Amorita Apilado providing administrative, logistical, and numerous other support functions. Kelly Kim of Caelum Research Corporation also supported VLBI operations and maintenance during 24-hour experiments and as backup support.

On April 9, 2011 the NENS contract transitioned to the SCNS contract operated by ITT



Table 2. Technical parameters of the radio telescope at KPGO.

Parameter	Kokee Park
owner and operating agency	USNO-NASA
year of construction	1993
radio telescope system	Az-El
receiving feed	primary focus
diameter of main reflector $d$	20m
focal length $f$	8.58m
$f/d$	0.43
surface contour of reflector	0.020inchesrms
azimuth range	0...540°
azimuth velocity	2°/s
azimuth acceleration	1°/s <sup>2</sup>
elevation range	0...90°
elevation velocity	2°/s
elevation acceleration	1°/s <sup>2</sup>
X-band (reference $\nu = 8.4GHz, \lambda = 0.0357m$ )	8.1 – 8.9 GHz
$T_{sys}$	40 K
$S_{SEFD}(CASA)$	900 Jy
$G/T$	45.05 dB/K
$\eta$	0.406
S-band (reference $\nu = 2.3GHz, \lambda = 0.1304m$ )	2.2 – 2.4 GHz
$T_{sys}$	40 K
$S_{SEFD}(CASA)$	665 Jy
$G/T$	35.15 dB/K
$\eta$	0.539
VLBI terminal type	VLBA/VLBA4-Mark 5
Field System version	9.7.6

Information Systems. The staff at Kokee Park consisted of six people under the new contract to NASA. Matt Harms retired, and Kiah Imai and Lawrence Chang were added to the Kokee Park staff to conduct VLBI operations and maintenance.

#### 4. Status of KPGO

Kokee Park has participated in many VLBI experiments since 1984. We started observing with GAPE, continued with NEOS and CORE, and are now in IVS R4 and R1. We also participate in the RDV experiments. We averaged 1.5 experiments per week during calendar year 2000 and increased to an average of two experiments of 24 hours each week, with daily Intensive experiments starting in year 2002 and continuing into 2011. After the earthquake in Japan in March 2011,

KPGO supported weekend Intensive experiments for the rest of the year while data from the Tsukuba VLBI station was being analyzed for supporting weekend Intensive experiments.

Kokee Park also hosts other systems, including a 7-m PEACESAT command and receive antenna, a DORIS beacon, a QZSS monitoring station, a TWSTFT relay station, and a Turbo-Rogue GPS receiver. Kokee Park is an IGS station.

In October 2007, Japanese interests, along with representatives from NASA, USNO, and the State Department, held a meeting at KPGO to explore the possible installation of a project called Quasi-Zenith Satellite System (QZSS). In 2008, further investigation continued towards making the QZSS project a part of KPGO. NASA sent an engineering team to investigate the support requirements that would be needed to implement the QZSS project here, and an engineering team from Japan surveyed the site for the hardware that would be installed. The aging KPGO infrastructure was upgraded in stages as the project progressed. In October 2009, the power at KPGO was upgraded to support the QZSS and Two-Way Satellite Time and Frequency Transfer (TWSTFT) requirements. In March 2010 the construction of the antenna base for the project was completed, and all components were installed and tested. In July 2010 the TWSTFT for the project was operationally configured by USNO and NICT.

In June 2010, the remote control capability for the DORIS beacon was installed at KPGO.

In October 2010, two members of the Ny-Ålesund VLBI team visited KPGO for the sharing of processes and procedures on operations and maintenance.

Also, in 2008, advances were made for making real-time VLBI data from KPGO a reality. The agencies that will be responsible for the wideband pipes leading from the site entered into a service agreement late in 2008. The coordination with the parties involved in the communication infrastructure upgrades continued through 2010. While work continues towards implementing the final architecture, an interim configuration has permitted some successful testing. Initially, the daily Intensive experiments are being targeted so that correlation back at the Washington Correlator can happen days earlier than it previously did. 24-hour experiment data flow will hopefully follow when the final architecture is implemented. The testing of the new communication infrastructure progressed slowly in 2011 but looks more promising in 2012.

## 5. Outlook

KPGO will be undergoing incremental changes and upgrades in the coming year to replace aging components as well as preparing to support VLBI2010 technical specifications. Plans are in progress to upgrade the KPGO backend to use the RDBE architecture in 2012. The Mark 5B+ data recorders will be upgraded to a Mark 5C. There are plans to migrate the e-transfer data connection to dedicated fiber supporting 1 Gbit/s or higher data rates. Plans are in progress for developing a new receiver box and feed for the 20-m antenna to support VLBI2010 specifications. Discussions are also in progress that may bring to KPGO a new 12-m antenna capable of supporting VLBI2010 specifications, including the faster slew rates.

KPGO's support of the PEACESAT mission will end in 2012 as the project comes to an end.

CNES has reached out to NASA on the possibility of upgrading KPGO to be part of their REGINA Network.



Figure 1. KPGO VLBI 20-m antenna (right) with the old NASA USB 9-m antenna in the background.



Figure 2. TWSTFT antennas.



Figure 3. DORIS remote control (left foreground) and beacon (right foreground).



Figure 4. QZSS/TWSTFT equipment racks.

## Matera CGS VLBI Station

*Giuseppe Bianco, Giuseppe Colucci, Francesco Schiavone*

### Abstract

This report describes the status of the Matera VLBI station. Also, an overview of the station, some technical characteristics of the system, and staff addresses are given.

### 1. General



Figure 1. The Matera “Centro di Geodesia Spaziale” (CGS).

The Matera VLBI station is located at the Italian Space Agency’s ‘Centro di Geodesia Spaziale G. Colombo’ (CGS) near Matera, a small town in the south of Italy. The CGS came into operation in 1983 when the Satellite Laser Ranging SAO-1 System was installed at CGS. Fully integrated into the worldwide network, SAO-1 was in continuous operation from 1983 up to 2000, providing high precision ranging observations of several satellites. The new Matera Laser Ranging Observatory (MLRO), one of the most advanced Satellite and Lunar Laser Ranging facilities in the world, was

installed in 2002 and replaced the old SLR system. CGS also hosted mobile SLR systems MTLRS (Holland/Germany) and TLRs-1 (NASA).

In May 1990 the CGS extended its capabilities to Very Long Baseline Interferometry (VLBI), installing a 20-m radio telescope. Since then, Matera has performed in 824 sessions up through December 2011.

In 1991 we started GPS activities, participating in the GIG 91 experiment and installing at Matera a permanent GPS Rogue receiver. In 1994 six TurboRogue SNR 8100 receivers were purchased in order to create the Italian Space Agency GPS fiducial network (IGFN). At the moment 12 stations are part of the IGfN, and all data from these stations, together with 24 other stations in Italy, are archived and made available by the CGS Web server GeoDAF (<http://geodaf.mt.asi.it>).

In 2000 we started activities with an Absolute Gravimeter (FG5 Micro-G Solutions). The gravimeter operates routinely at CGS, and it is available for external campaigns on request.



Figure 2. MLRO in action, photo courtesy of Francesco Ambrico.

Thanks to the co-location of all precise positioning space based techniques (VLBI, SLR, LLR, and GPS) and the Absolute Gravimeter, CGS is one of the few “fundamental” stations in the world. With the objective of exploiting the maximum integration in the field of Earth observations, in the late 1980s ASI extended CGS’ involvement also to remote sensing activities for present and future missions (ERS-1, ERS-2, X-SAR/SIR-C, SRTM, ENVISAT, and COSMO-SkyMed).

## 2. Technical/Scientific Overview

The Matera VLBI antenna is a 20-meter dish with a Cassegrain configuration and an AZ-EL mount. The AZ axis has  $\pm 270$  degrees of available motion. The slewing velocity is 2 deg/sec for both the AZ and the EL axes.

The technical parameters of the Matera VLBI antenna are summarized in Table 1.

The Matera time and frequency system consists of three frequency sources (two Cesium beam and one H-maser standard) and three independent clock chains. The EFOS-8 H-maser from Oscilloquartz is used as a frequency source for VLBI.

Table 1. Matera VLBI Antenna Technical Specifications.

Input frequencies	S/X	2210–2450 MHz / 8180–8980 MHz
Noise temperature at dewar flange	S/X	<20 K
IF output frequencies	S/X	190–430 MHz / 100–900 MHz
IF Output Power (300 K at inp. flange)	S/X	0.0 dBm to +8.0 dBm
Gain compression	S/X	<1 dB at +8 dBm output level
Image rejection	S/X	>45 dB within the IF passband
Inter modulation products	S/X	At least 30 dB below each of 2 carriers at an IF output level of 0 dBm per carrier
$T_{sys}$	S/X	55/65 K
SEFD	S/X	800/900 Jy

### 3. Staff

The list of the VLBI staff members of the Matera VLBI station is provided in Table 2.

Table 2. Matera VLBI staff members.

Name	Agency	Activity	E-Mail
Dr. Giuseppe Bianco	ASI	Space Geodesy Manager	giuseppe.bianco@asi.it
Francesco Schiavone	e-geos	Operations Manager	francesco.schiavone@e-geos.it
Giuseppe Colucci	e-geos	VLBI contact	giuseppe.colucci@e-geos.it

### 4. Status

In 2011, 59 sessions were observed. Figure 3 shows a summary of the total acquisitions per year, starting in 1990.

In 2004, in order to fix the existing rail problems, a complete rail replacement had been planned. In 2005, due to financial difficulties, it was instead decided that only the concrete pedestal under the existing rail would be repaired. From then on, no rail movements have been noted [1]-[3].

### 5. Outlook

In order to plan the eventual building of a VLBI2010 system, the fund raising investigation process has been started. At this moment it is not clear when the budget for starting the project will be ready.

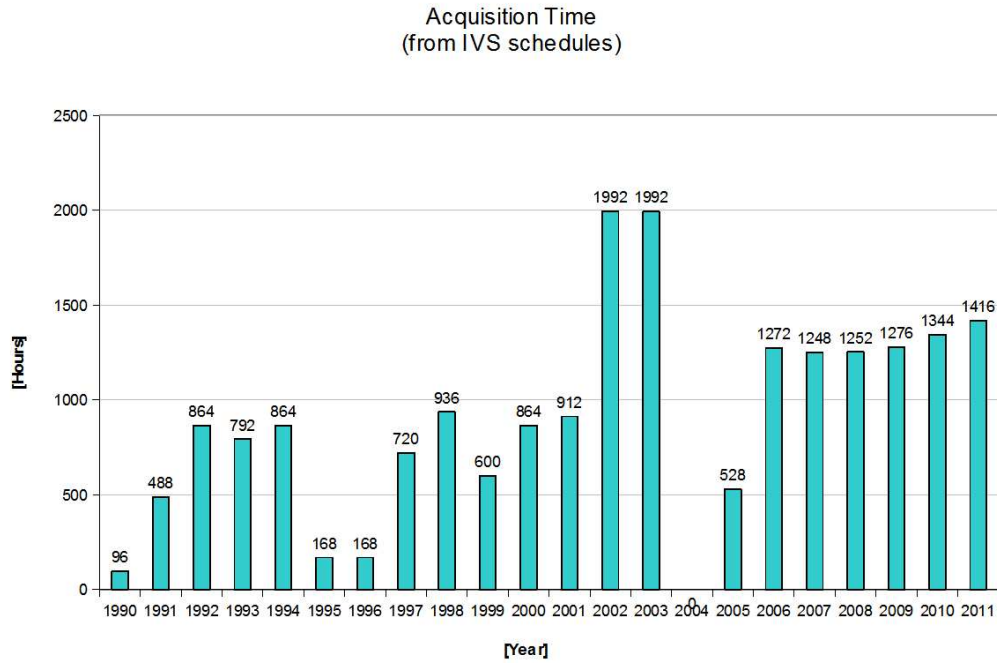

Figure 3. Acquisitions per year.

The replacement of two azimuth wheels is planned for 2012. The other two were replaced in 2008 and 2009 respectively.

The process of purchasing a new H-Maser has been already started. The delivery of the new unit is planned for 2013.

### References

- [1] M. Mannarella “Relazione sulle misure effettuate sulla rotaia dell’antenna VLBI”, Telespazio doc. OT-SPA-SM\_REL\_180010\_1140\_0222, 21/01/2004.
- [2] M. Mannarella “Misure sugli spostamenti indotti sulle piastre e sulla rotaia dell’antenna VLBI”, Telespazio doc. OT-SPA-SM\_REL\_180010\_1320\_0661, 06/04/2005.
- [3] M. Mannarella “Relazione sull’esito dei lavori di ripristino delle parti ammalorate della fondazione dell’antenna VLBI”, Telespazio Doc. OT-SPA-SM\_REL\_180010\_1320\_0732, 27/06/2005.

# The Medicina Station Status Report

*Alessandro Orfei, Andrea Orlati, Giuseppe Maccaferri*

## Abstract

General information about the Medicina Radio Astronomy Station, the 32-m antenna status, and the staff in charge of VLBI observations is provided. In 2011 the data from geodetic VLBI observations were acquired using the Mark 5A recording system with good results. Updates of the hardware have been performed and are briefly described.

## 1. The Medicina 32-m Antenna: General Information

The Medicina 32-m antenna is located at the Medicina Radio Astronomy Station. The station is run by the Istituto di Radioastronomia and is located about 33 km east of Bologna. The Consiglio Nazionale delle Ricerche was the funding agency of the Istituto di Radioastronomia until the end of 2004. Since January 1, 2005 the funding agency has been the Istituto Nazionale di Astrofisica (INAF).

The antenna, inaugurated in 1983, has regularly taken part in IVS observations since 1985 and is an element of the European VLBI network. A permanent GPS station (MEDI), which is part of the IGS network, is installed in the vicinity. Another GPS system is installed near the VLBI telescope (MSEL) and is part of the EUREF network.

## 2. Antenna Description

The Medicina antenna has Cassegrain optics, consisting of a primary mirror of 32-m in diameter, and a secondary mirror, called the subreflector, of convex shape and about 3-m in diameter. The subreflector, mounted on a quadrupode, is placed opposite the primary mirror and focuses the radio waves at its center, where the receiver system is located. For some observing frequencies, a simplified optical system is enough. The subreflector is therefore shifted from its normal position, and the receiving system is placed at the primary focus. This is the case for the S-X observations. The antenna can operate in the range between 327 MHz and 22 GHz.

The receivers are cooled with cryogenic techniques to improve the system sensitivity. The antenna's operative receiver is easily changed; only a few minutes are needed to change the observing frequency. A recent picture of the antenna is shown in Figure 1.

## 3. The Staff

Many scientists and technicians take care of the observations. However, a limited number are dedicated to maintaining and improving the reliability of the antenna during the observations: Alessandro Orfei is the Chief Engineer, expert in microwave receivers; and Andrea Orlati, Software Engineer, takes care of the observing schedules and regularly implements SKED, DRUDG, and the Field System. At the end of 2010 Giuseppe Maccaferri took a one-year sabbatical period. Marco Bartolini and Simona Righini have been temporarily included in the staff helping Andrea Orlati for the VLBI preparation and observation.





Figure 1. View of the Medicina 32-m dish taken during geodetic VLBI observations. Note that the subreflector is shifted to allow the use of the S/X receiver located in the primary focus of the radio telescope.

#### 4. Current Status and Activities

The board to upgrade our version of Mark 5 to Mark 5C has been purchased. At the same time an order has been placed to buy a DBBC equipped with ADB2 and CORE2 boards. An added FILA10G Ethernet interface will allow the use of it with Mark 5C.

The antenna will be provided with a new Helium pipeline and cryo compressors. The cold head will be substituted in the receivers.

A plan for heavy and extraordinary maintenance is in progress. The first step is to provide materials and contracts. The H-Maser is near the end of its life; it has been decided to buy a new one.

The upgrade to 10 Gb/s is still in progress, as is the creation of a 10 Gb/s POP center at Bologna Headquarters.

#### 5. Geodetic VLBI Observations

In 2011 Medicina took part in 23 (24-hour) routine geodetic sessions (namely 2 IVS-T2, 18 IVS-R4, 2 EUROPE, and 1 R&D experiments).

## VERA Geodetic Activities

*Takaaki Jike, Seiji Manabe, Yoshiaki Tamura, Makoto Shizugami, VERA group*

### Abstract

The geodetic activities of VERA in the year 2011 are briefly described. The regular geodetic observations are carried out both in K- and S/X-bands. The frequency of regular observations are three times a month—twice for the VERA internal observations in K-band. The networks of the S/X sessions are JADE of GSI and IVS-T2. The raw data of the T2 and JADE sessions are electronically transferred to the Bonn, Haystack, and GSI correlators via Internet.

Gravimetric observations are carried out at the VERA stations. The superconducting gravimeter previously installed at Esashi Earth Tides Station was moved to Mizusawa and placed in the vicinity of the VERA antenna in order to monitor vertical displacement at the end of 2008, and the observation continued throughout the year.

The 2011 earthquake off the Pacific coast of Tohoku generated step-like and creeping-like movements to the VERAMZSW position.

### 1. General Description

VERA is a Japanese domestic VLBI network consisting of the Mizusawa, Iriki, Ogasawara, and Ishigakijima stations. Each station is equipped with a 20-m radio telescope and a VLBI backend. The VERA-Mizusawa antenna and the Mizusawa 10-m antenna are shown in Figure 1. In this figure, the antenna in the front is the Mizusawa 10-m antenna, and the one in the back is the VERA-Mizusawa antenna. The VERA array is controlled from the Array Operation Center at Mizusawa via Internet.

The primary scientific goal of VERA is to reveal the structure and the dynamics of our galaxy by determining 3-dimensional force field and mass distribution. Galactic maser sources are used as dynamical probes, the positions and velocities of which can be precisely determined by phase referenced VLBI relative to extragalactic radio sources. The distance is measured as a classical annual trigonometric parallax. The observing frequency bands of VERA are S and X, K (22 GHz), and Q (43 GHz). Geodetic observations are made in S/X- and K-bands. Q-band is currently not used for geodesy. Only a single beam is used even in K-band in geodetic observations, although VERA can observe two closely separated ( $0.2^\circ < \text{separation angle} < 2.2^\circ$ ) radio sources simultaneously by using the dual beam platforms.

General information about the VERA stations is summarized in Table 1, and the geographic locations are shown in Figure 2. Lengths of baselines range from 1000 km to 2272 km. The skyline at Ogasawara station ranges from  $7^\circ$  to  $18^\circ$  because it is located at the bottom of an old volcanic crater. The north-east sky at Ishigakijima station is blocked by a nearby high mountain. However, the majority of the skyline is below  $9^\circ$ . The skylines at Mizusawa and Iriki are low enough to observe sources with low elevation. Since Ogasawara and Ishigakijima are small islands in the open sea and their climate is subtropical, the humidity in the summer is very high. This brings about high system temperatures in the summer, in particular in K and Q bands. Iriki station as well as these stations are frequently hit by strong typhoons. The wind speed sometimes reaches up to 60–70 m/s.



Figure 1. VERA-Mizusawa antenna and Mizusawa 10-m antenna.

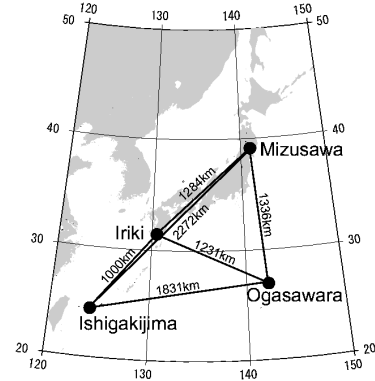

Figure 2. Location of the VERA stations.

Table 1. General information.

Sponsoring agency	Mizusawa VLBI Observatory, National Astronomical Observatory of Japan	
Contributing type	Network observing station	
Location	Mizusawa	141° 07' 57".199 E, 39° 08' 00".726 N, 75.7 m(sea level)
	Iriki	130° 26' 23".593 E, 31° 44' 52".437 N, 541.6 m(sea level)
	Ogasawara	142° 12' 59".809 E, 27° 05' 30".487 N, 223.0 m(sea level)
	Ishigakijima	124° 10' 15".578 E, 24° 24' 43".834 N, 38.5 m(sea level)

## 2. Technical Parameters

Parameters of the antennas and front- and back-ends are summarized in Tables 2 and 3, respectively. Two observing modes are used in geodetic observations. One is the VERA internal observation in K-band with the recording rate of 1 Gbps. The other is the conventional S/X-band observation with K5-VSSP. JADE, which is GSI's domestic observation project, and IVS-T2 sessions belong to this class. Only Mizusawa and Ishigakijima participated in these sessions.

Table 2. Antenna parameters.

Diameter	20m	Slew	Azimuth	Elevation
Mount	Az-El	range	-90° – 450°	5° – 85°
Surface accuracy	0.2mm(rms)	speed	2.1°/sec	2.1°/sec
Pointing accuracy	<12" (rms)	acceleration	2.1°/sec <sup>2</sup>	2.1°/sec <sup>2</sup>

	S	X	K
HPBW	1550"	400"	150"
Aperture efficiency	0.25	0.4	0.47

Table 3. Front-end and back-end parameters.

Front-end					
Frequency band	Frequency range(GHz)	Receiver temperature	Polarization	Receiver type	Feed
S	2.18–2.36	100°K	RHC	HEMT	Helical array
X	8.18–8.60	100°K	RHC	HEMT	Helical array
K	21.5–24.5	39±8°K	LHC	HEMT(cooled)	Horn
Back-end					
Type	channels	BW/channel	Filter	Recorder	Deployed station
VERA	16	16MHz	Digital	DIR2000	4 VERA
K5-VSSP	16	4MHz	VC	HDD	Mizusawa Ishigakijima

### 3. Current Status and Activities

#### 3.1. VLBI

VERA observes seven days a week except for the maintenance period in the summer. The nominal frequency of geodetic observations is three days a month. Among these three, VERA internal geodetic observations in K-band are performed twice a month, and Mizusawa and Ishigakijima participate in JADE by GSI or IVS-T2 sessions in S/X-band on a once-a-month basis. The main purpose of the VERA internal geodetic observations is to determine relative positions of the VERA antennas accurate enough for astrometric requirements. The purpose of the S/X sessions is to make the VERA coordinates refer to the IVS reference frame. The reason for the shift of the observing frequency band from S/X-band to K-band is to avoid the strong radio interference by cellular phone in S-band, particularly at Mizusawa. The interfering signal which has line spectra is filtered out. However, this filtering considerably degrades the system noise temperature. It is likely that the S-band observation will become impossible in the near future. On the other hand, VERA has the highest sensitivity in K-band as shown in Table 3. Thanks to the high sensitivity in this band the maximum number of scans in K-band is 800/station/24-hours, while that in S/X-band is 500 at most. It has been confirmed that the K-band observations are far more precise, although the ionospheric delay is not corrected for. In fact, standard deviations of the individual determinations of the antenna positions in K-band are less than half of those in S/X-band.

In order to link the VERA network to the international reference frame, VERA continues participation in the IVS-T2 sessions by using the Mizusawa and Ishigakijima stations. In 2011, we participated in seven T2 sessions and in three JADE sessions. VERA internal geodetic observations were carried out 18 times. The final estimation of the geodetic parameters are derived by using the software developed by the VERA team.

### 3.2. Other Activities

Continuous GPS observations were carried out at each VERA station throughout the year. The superconducting gravimeter (SCG) was moved from the Esashi Earth Tides Station to Mizusawa in order to accurately monitor gravity change for the purpose of monitoring height change at the VERA Mizusawa station. Four water table gauges surrounding the SCG were used for monitoring the water table height. SCG was installed also in the VERA Ishigakijima station in January 2012. The preliminary results show that gravity variation due to the variation of the water table can be corrected as accurately as the  $1\mu\text{gal}$  level.

## 4. The 2011 Earthquake Off the Pacific Coast of Tohoku

The strong quakes by the 2011 earthquake off the Pacific coast of Tohoku ( $M_w=9.0$ ) [Epoch=11 March 2011, 14:16:18 JST] damaged the VERA-Mizusawa 20-m antenna. Operations of the VERA-Mizusawa antenna stopped five weeks after the earthquake and for ten weeks of the repair period. VERAMZSW was displaced by co-seismic crustal movement and post-seismic creeping. These movements are clearly detected from VERA internal geodetic VLBI observations and continuous GPS observations. During the approximately three minutes of seismic motion, VERAMZSW was displaced 3.4 m at the maximum and shifted 2.4 m in the direction of east-northeast eventually. The co-seismic steps are  $X=-1.924$  m,  $Y=-1.227$  m, and  $Z=-1.062$  m in the geocentric Cartesian coordinate system. The direction of the creeping is well agreed with the direction of co-seismic slip (Figure 3). Total length of the movement by the post-seismic creeping is 40.6 cm between 12 March and 31 December, 2011. This creeping is gradually decreasing but still continues.

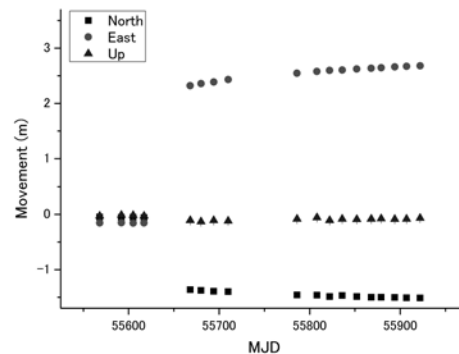

Figure 3. Movements of VERAMZSW after the 2011 earthquake.

## 5. Staff Members

The Mizusawa VERA Observatory of NAOJ was reorganized as the Mizusawa VLBI Observatory in April 2009. VERA and VSOP-2 were integrated into a unified project. Noriyuki Kawaguchi was inaugurated as Director in April 2010. The geodesy group consists of S. Manabe (scientist), Y. Tamura (scientist), T. Jike (scientist), and M. Shizugami (software technician).

## Noto Station Status Report

*G. Tuccari, F. Schilliró, P. Cassaro, S. Buttaccio, C. Contavalle, F. Giacalone, N. Lombardo, G. Nicotra, L. Nicotra, C. Nocita, L. Papaleo, M. Paternó, P.R. Platania*

### Abstract

The year 2011 for the Noto station has been one of great renovation and of important improvements for its observational capabilities. In particular we are able to mention four key projects that were completed or under way.

### 1. Repairs of Azimuthal Axis of Rotation

In recent years, there has been a tangible and sensible decrease of the mechanical performance of the antenna, mainly due to mechanical wear of components of the system, in particular related to the system of the azimuth rotation axis of the telescope and all subparts that compose it: rail track, base metal plates, wheels, reducer gears, and especially the grout. The slow action of wear and tear of time and weather has gradually deteriorated the state of these components and their assembly, affecting not only the antenna observational parameters (pointing accuracy, tracking speed and accuracy, camber angle of the wheels, and the proper angle of the rotation axes (affecting the geo antenna point)), but also the stiffness of the antenna, so that in March 2010 a structural failure of a wheel bearing stopped the antenna activity and caused the necessity of completely repairing the azimuth rotation axis. During 2011 the station activities have been focused on the organization of this repair work; in particular the search for funding—about 700K Euro fully funded by the Ministry of Research (of which INAF is part), the execution of preparatory paperwork and project design, drafting the implementation of the projects, and the actual activity. This last phase took about 13 weeks; it was completely performed by a highly qualified Italian company, Galbiati Srl, and it can be described in three main parts:

- 1) a. Dismantling of the mechanical parts and anchorages to the main azimuth bearing (see Figure 1);
  - b. plucking up of the rail track, metal plates and grout that capture and support the rail;
  - c. performing of reference measurements;
- 2) Installation and grouting of the support plates, including the maturation phase of the grout (28 days) (see Figure 2);
- 3) a. Installation of new mechanical parts such as rails, bolts and gears (see Figure 3).
  - b. Performing of new reference measurements.

The work was completed with the phases of protection and painting of the antenna base, cleaning of reflective surfaces (especially primary optics) and the alignment of the telescope and pointing systems reprogramming (see Figure 4). Radio telescope parameters have been restored like the original ones by project, in particular for the correction of the camber angle of the wheels (average  $9'$  over  $2^\circ 52'$ ), and the orthogonal offset recovery (about  $10''$ ) of both elevation and azimuth axis.



Figure 1. a) Rail track removal



b) Grout removal, metal plates visible



Figure 2. a) Continuous metal plate installation and b) grouting phase



Figure 3. a) New wheels



b) Wheel, support and reducer gear coupling



Figure 4. It's the end of the work!!!



## 2. Fiber Optics Connection

A fiber optics link for e-VLBI activities has been financed by GARR (Italian Academic and Research Network) and it is now ready to start with a 1 Gbps data rate starting in March 2012, and 10 Gbps probably starting in September 2012.

## 3. Frequency Agility

A frequency agility system is now in the design phase. This system will install a set of receivers in the antenna secondary focus, so that the receivers will automatically be available within a few minutes. The primary focus will receive a revised version of the SXL receiver that was developed some years ago but was never used due to the difficult mechanical operations required to implement it for regular observing. This project has been funded, and the activities will start in summer 2012.

## 4. DBBC2010 for VLBI2010 Observations

The Noto station will participate in VLBI observing with the legacy antenna. This will require the adoption of a wide band receiver and a dedicated back-end. The first will be assembled as soon as the feed becomes available, following the VLBI2010 Committee recommendations, while the back-end will be upgraded during 2012. This requires the installation of four additional IFs in the existing DBBC system, as well as a number of additional boards, which will make the system compatible with the required specifications. In particular the FILA10G network board will be adopted to support the high output data rate. A Mark 6 recorder will be supported at 32 Gbps. At the same time the DBBC3 Project has been financed by Radionet and will formally start in July 2012. Such a new back-end will provide the entire two polarization 14 GHz band coverage in full digital fashion, including support for the data process and multiple 100G network capability.

# Ny-Ålesund 20-meter Antenna

*Carl Petter Nielsen*

## Abstract

In 2011, the 20-meter VLBI antenna at the Geodetic Observatory, Ny-Ålesund, has participated in VLBI experiments, observing 115 of 115 scheduled 24-hour experiments, 35 of 41 scheduled Intensives and the CONT in September. Reasons for the lost Intensive experiments were cancellations due to the disabling of the Tsukuba antenna by the earthquake in Japan. In 2011, Ny-Ålesund was manned by four employees dividing three positions between them—Carl Petter Nielsen as base commander and Geir Mathiassen, Moritz Sieber, and Lars Karvonen as engineers, all working 75%. In November Lars Karvonen was replaced by Åsmund Skjæveland. In connection with our VLBI2010 application, the Norwegian Mapping Authority (NMA) was granted 219 million NOK from the Norwegian Government.

## 1. General Information

The Geodetic Observatory of the NMA is situated at 78.9 N and 11.87 W in Ny-Ålesund, in Kings Bay, at the west side of the island of Spitsbergen. This is the biggest island in the Svalbard archipelago. In 2011, Ny-Ålesund was scheduled for 115 24-hour VLBI experiments, including R1, R4, EURO, RD, T2, and RDV sessions, and 41 1-hour Intensives within the Int1/Int3 program. Five Intensive experiments were cancelled due to the earthquake in Japan that disabled the Tsukuba antenna. One Intensive had to be cancelled because of station problems. The rest of the 150 experiments were run as planned. Ny-Ålesund also participated successfully in the CONT in September.

In addition to the 20-meter VLBI antenna, the Geodetic Observatory has two GPS antennas in the IGS system and a Super Conducting Gravimeter in the Global Geodynamics Project (GGP) installed at the site. There is also a SATREF (dGPS) installation at the station. At the French research station in Ny-Ålesund, there is a DORIS station. In October 2004 a GISTM (GPS Ionospheric Scintillation and TEC Monitor) receiver was installed at the Mapping Authority structure in the frame of ISACCO, an Italian research project on ionospheric scintillation observations, led by Giorgiana De Franceschi of the Italian Institute of Geophysics and Volcanology (INGV).

## 2. Component Description

The antenna is intended for geodetic use and is designed for receiving in S-band and X-band. Ny-Ålesund is located so far north that the sun is below the horizon from the 23rd of October until the 22nd of February and has midnight sun from the 20th of April to the 27th of August. The station is situated under the auroral circle during the daytime, giving some extra disturbance in the ionosphere, but generally the polar atmosphere is calmer than the atmosphere closer to the equator.



Figure 1. Ny-Ålesund antenna.

### 3. Staff

Table 1. Staff related to VLBI operations at Ny-Ålesund.

Hønefoss:	Section manager:	Line Langkaas
	Station responsible at Hønefoss:	Line Langkaas
Ny-Ålesund:	Station commander:	Carl Petter Nielsen
	Engineer	Geir Mathiassen
	Engineer	Moritz Sieber
	Engineer	Lars Karvonen until 2011.10.01
	Engineer	Åsmund Skjæveland since 2011.11.15

Carl Petter Nielsen has a three-year contract as base commander, ending 2012.12.31. Geir Mathiassen and Moritz Sieber have two-year contracts as engineers ending 2012.09.01 and 2013.07.31, respectively. Lars Karvonen terminated his contract on 2011.10.01 and was replaced by Asmund Skjæveland on 2011.11.15. When Carl Petter Nielsen is off, one of the others step in as base commander.

## 4. Current Status and Activities

Ny-Ålesund participated in the scheduled VLBI experiments. During 2011 e-transfer was extended to transfer all experiments from Ny-Ålesund to the different correlators. The fiber-cable between Longyearbyen and Ny-Ålesund was postponed until 2013/2014. The new cable will enable us to take part in real time correlation as opposed to our present radiolink, which is 100 Mbit/s.

The Super Conducting Gravimeter (SCG) placed on the same foundation as IGS-GPS NYA1 has been running without problems. The yearly service on the system was performed by the staff in September. There were some problems in transporting the liquid helium (LHe) to Ny-Ålesund. Due to the 2–3 weeks it takes to transport the LHe to Ny-Ålesund, most of it might turn into gas on the journey, especially if the ship experiences bad weather. We also experienced increasing problems transferring LHe from the transport container to the gravimeter. As a result we had three shipments of LHe in 2011. To reduce the running cost of the gravimeter the NMA is applying for a new gravimeter with a built-in regenerating LHe system. National Astronomical Observatory of Japan, Mizusawa VERA Observatory, which owns the SCG, lent this equipment to NMA starting 2007.04.01, to continue the scientific measurement series.

NMA plans to take part in VLBI2010 and was granted 219 million NOK from the Norwegian Government for two new antennas and SLR. Ny-Ålesund is an Arctic research village, and the scientific community (organized in NySMAC) would like to keep the surroundings as pristine and unaffected by human activity as possible. Therefore NMA has initiated an extensive Environmental Impact Assessment (EIA) involving the different interested parties. This work is soon to be finished enabling us to complete the planning of the project. Our hope is that everybody involved will find that the VLBI2010 project is acceptable for the ongoing research in Ny-Ålesund.

The Mark IV formatter was replaced with a Mark 5 sampler. Mark 5B is now used as the recorder, and Mark 5A is used for transferring data to correlators. In early May the receiver-monitorsystem broke down, and we are in the process of replacing it with an alternative PLC-system.

In order to improve the skills of the staff some measures were taken. In March, Geir Mathiassen and Lars Karvonen visited Wettzell. Lars Karvonen and Moritz Sieber attended the Technical Operations Workshop (TOW) in early May, and Moritz Sieber attended the ILRS workshop in Wettzell in the middle of May. Carl Petter Nielsen and Moritz Sieber visited Wettzell in June. A climbing and safety course was held in November. In November Moritz Sieber studied the SLR at Wettzell, and during that period Kent Roskifte substituted for him in Ny-Ålesund.

During August the roof was insulated against the arctic cold, and two heat-pumps were installed to improve our energy budget. The lift was treated for rust and repainted. A new car was bought in October, and the oldest car was sold.

Our present antenna is scheduled to observe until 2022, when it will be taken down due to airport safety. A representative for Vertex inspected the antenna in August and produced a list of measures that need to be carried out in order to keep our old lady alive.

## 5. Future Plans

Ny-Ålesund will continue to participate in the 123 regular and 46 Intensive experiments. Our aim is to use e-transfer for all transfers of data. A new system for monitoring the receiver will be

implemented.

During 2012 competitive tendering for the different parts of the VLBI2010 project will be carried out. Hopefully work on the infrastructure can start in late 2012. The new fiber-cable between Longyearbyen and Ny-Ålesund has been delayed. Depending on the availability and price of cable-ships the fiber-cable will be laid during the summer of 2012 or 2013.

# German Antarctic Receiving Station (GARS) O'Higgins

*Christian Plötz, Thomas Klügel, Alexander Neidhardt*

## Abstract

In 2011 the German Antarctic Receiving Station (GARS) O'Higgins contributed to the IVS observing program with four observation sessions. Maintenance and upgrades were made. A new replacement dewar is under construction.

## 1. General Information

The German Antarctic Receiving Station (GARS) is jointly operated by the German Aerospace Center (DLR) and the Federal Agency for Cartography and Geodesy (BKG, belongs to the duties of the Geodetic Observatory Wettzell (GOW)). The Institute for Antarctic Research Chile (INACH) coordinates the activities and logistics. The 9-m radio telescope at O'Higgins is used for geodetic VLBI and for downloading of remote sensing data from satellites like ERS-2 (mission ended in September 2011) and TanDEM-X as well as for commanding and monitoring of spacecraft telemetry. In 2011 the station was manned by DLR staff the entire year and by BKG staff only in January and February for the VLBI observations. The VLBI campaign in November-December 2011 had to be cancelled due to logistical circumstances. Besides engineers and operators from DLR and BKG, a team for maintaining the infrastructure (e.g., power and freshwater generation) was present all over the year.

Over the last years, special flights using "Hercules C-130" aircraft and small "Twin Otter DHC-6" aircraft as well as transportation by ship were organized by INACH in close collaboration with the Chilean Army, Navy, and Airforce and with the Brazilian and Uruguayan Airforce in order to transport staff, technical material, and food for the entire campaign from Punta Arenas via Base Frei on King George Island to O'Higgins on the Antarctic Peninsula. Due to the fact that the conditions for landing aircraft on the glacier are strongly weather dependent and involve an increasing risk, the usage of ships for transportation becomes more and more important. In general, transport of personnel and cargo is always a challenging task. Arrival and departure times strongly depend on the weather conditions and on the logistical circumstances.

After the long Antarctic winter the VLBI equipment at the station has to be initialized. Damages resulting from the winter conditions or strong storms have to be identified and repaired. Shipment of each kind of material like spare parts or upgrade kits has to be carefully prepared in advance.

Beside the 9-m radio telescope for VLBI, the following instruments are operated:

- a H-Maser, an atomic Cs-clock, a GPS time receiver and a Total Accurate Clock (TAC) offer time and frequency.
- two GNSS receivers both operating in the frame of the IGS network, while one receiver is additionally part of the Galileo CONGO network. The receivers worked without failure in 2011.
- a meteorological station providing pressure, temperature and humidity and wind information, as long as the temporarily extreme conditions did not disturb the sensors.

- a radar tide gauge which was installed in 2011. The radar sensor itself is space referenced by a GPS-antenna mounted on top and Earth referenced via the local survey network. The radar gauge is operated only during the Antarctic summer.
- an underwater sea level gauge for permanent monitoring of water pressure, temperature, and salinity, which was replaced in 2011.

The 9-m radio telescope is designed for dual purpose:

- performing geodetic VLBI and
- receiving data from and sending commands to remote sensing satellites, mainly ERS-2 and TanDEM-X.



Figure 1. The 9-m radio telescope of GARS O'Higgins.

## 2. Technical Staff

The members of staff for operation, maintenance, and upgrade of the VLBI system and other geodetic devices are summarized in Table 1.

Table 1. Staff members

Name	Affiliation	Function	Working for
Johannes Ihde	BKG	interim head of the GOW (until February 2011)	GOW
Ulrich Schreiber	BKG	head of the GOW (since March 2011)	GOW
Christian Plötz	BKG	electronic engineer	O'Higgins (responsible), RTW
Reiner Wojdziak	BKG	software engineer	O'Higgins, IVS Data Center Leipzig
Thomas Klügel	BKG	geologist	administration for O'Higgins, laser gyro and local systems Wettzell
Rudolf Stoeger	BKG	geodesist	logistics for O'Higgins
Alexander Neidhardt	FESG	head of the RTW group and VLBI station chief	RTW, TTW (partly O'Higgins, laser ranging)
Gerhard Kronschnabl	BKG	electronic engineer	RTW, TTW (partly TIGO and O'Higgins)

### 3. Observations in 2011

GARS participated in the following sessions of the IVS observing program during the Antarctic summer campaign (January-February 2011)

- IVS-T2074 February 01.-02., 2011
- IVS-OHIG70 February 02.-03., 2011
- IVS-OHIG71 February 08.-09., 2011
- IVS-OHIG72 February 09.-10., 2011

The observations were recorded with Mark 5A. The related data modules were carried from O'Higgins to Punta Arenas by the staff on their way back. From Punta Arenas the disk units were shipped by regular air freight back to Wettzell and then to the correlator in Bonn, Germany.

### 4. Maintenance

The extreme environment conditions in the Antarctic require special attention to the GARS telescope and the infrastructure. Corrosion frequently results in problems with connectors and capacitors. Defective equipment needs to be detected and replaced. The antenna, the S/X-band receiver, the cooling system, and the data acquisition system have to be activated properly.

The construction of the new dewar is in progress in order to replace the original O'Higgins dewar. This one has to be evacuated permanently by a turbo molecular pump to maintain the required vacuum due to a leakage. Besides this the IF-Distributor was shipped to Wettzell to be repaired. The board for the communication with the NASA Field System bailed out and was replaced by a new one, and all damaged components were replaced. This turned out to be a difficult task, as some components as well as technical information are barely available anymore.



Figure 2. The new radar tide gauge which was installed in 2011.

### 5. Technical Improvements

A new backup system was installed which allows the copying of the VLBI data to a local disk in order to keep a copy of the raw data on site. The system has a capacity to store the data



of observation campaigns from one year. Data access and administration is possible via network communication.

The remote control of complete VLBI sessions could be extended. Using the newly developed Wettzell software, the O'Higgins Field System can be controlled over a secure Internet connection from Wettzell. This is a key feature to extend the operation periods in GARS O'Higgins.

## **6. Upgrade Plans for 2012**

The replacement dewar will be completed. A dedicated plan should offer a shared, interleaved observation of satellites (DLR) and VLBI sources (BKG) during the whole year. Some antenna motors must be replaced, and a gear needs to be inspected. There are further plans to replace the receiver with a more suitable, smaller, and more maintainable system, similar to the TWIN tri-band-receiver. This needs to be planned and designed.

## Onsala Space Observatory – IVS Network Station

*Rüdiger Haas, Gunnar Elgered, Johan Löfgren, Tong Ning, Hans-Georg Scherneck*

### Abstract

During 2011 we contributed to 38 IVS sessions, including the CONT11 campaign. We used the majority of the sessions that involved both Onsala and Tsukuba to do ultra-rapid dUT1 observations together with our colleagues in Tsukuba. In particular, the whole CONT11 campaign was operated in ultra-rapid mode. Furthermore, we observed one additional one-baseline ultra-rapid dUT1 session, a three-station ultra-rapid EOP-session, the Venus Express space probe, and the RadioAstron satellite.

### 1. General Information

The Onsala Space Observatory is a fundamental geodetic station with equipment for geodetic VLBI, GNSS, a superconducting gravimeter, and several radiometers for atmospheric measurements. Figure 1 shows an aerial photo taken on October 13, 2011.

The staff associated with the IVS Network Station at Onsala remained the same as reported in last year's report. Contact information is found on [www.chalmers.se/rss/oso-en/](http://www.chalmers.se/rss/oso-en/).

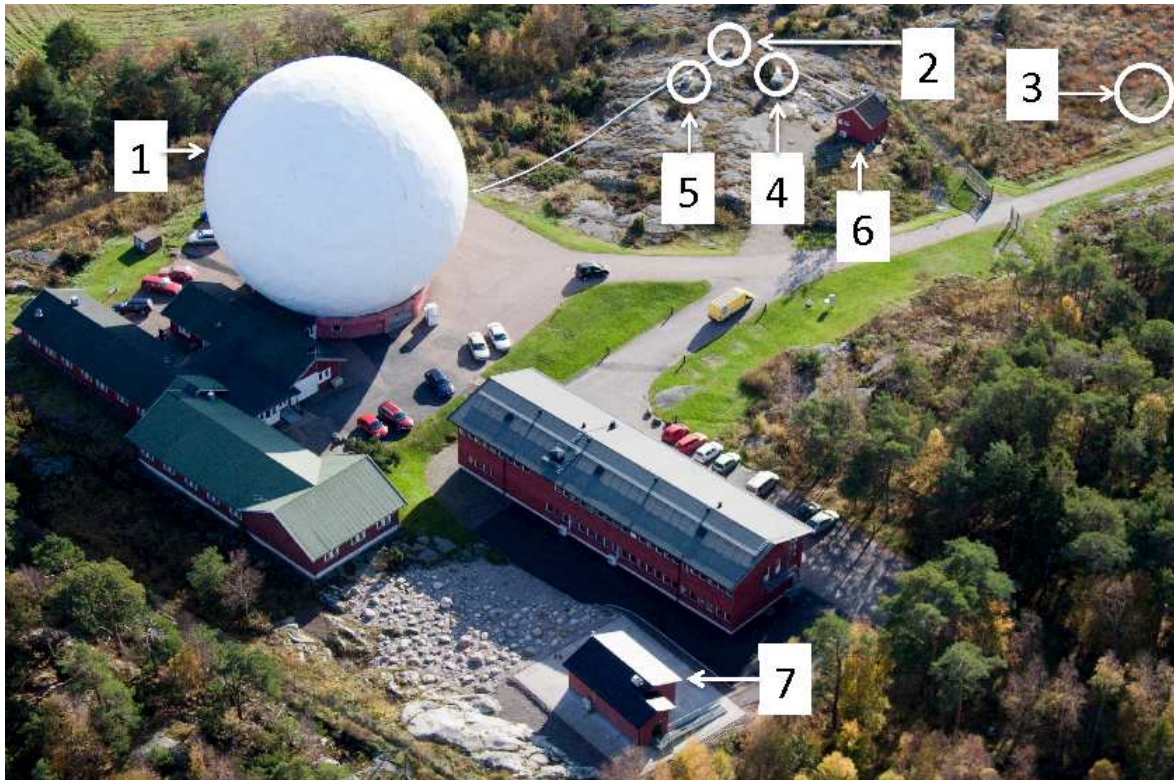

Figure 1. The radome enclosed 20-m radio telescope used for geodetic/astrometric VLBI (1), the IGS antenna (2), a new GNSS-monument erected in 2011 (3), the water vapor radiometers Astrid (4) and Konrad (5), the old laboratory for visiting gravimeters (6), and the new gravimeter laboratory (7).

## 2. VLBI Observations for Geodesy and Space Navigation

Onsala was involved in the four IVS observing series EUROPE, R1, T2, and RD and participated in the CONT11 campaign, see Table 1. Observations were acquired during 38 IVS sessions. All experiments were recorded with our Mark IV VLBI-rack and recorded on the Mark 5A unit. Most of the experiments whose data were correlated at the Bonn correlator were recorded in parallel on the PCEVN-computer that is daisy-chained to the Mark 5A unit. The observed data of these experiments were then e-transferred off-line using the Tsunami protocol, and no Mark 5 modules were actually sent to Bonn. The data to be correlated at the Haystack correlator were shipped on Mark 5 modules. However, the data of the last RD-session in 2011 were e-transferred off-line to the Haystack correlator, and no modules were shipped. The observational data of the CONT11 campaign were shipped on Mark 5 modules to the Washington correlator.

We used the majority of the sessions involving both Onsala and Tsukuba to perform ultra-rapid dUT1 observations. This was done for many of the R1- and RD-sessions, and all of the CONT11-sessions. In these cases the Onsala data were e-transferred in real-time to the Tsukuba correlator using the Tsunami protocol. The data were correlated with the corresponding data from the Tsukuba station in near real-time, followed by a near real-time analysis to determine dUT1. Using this automated strategy, dUT1 results were already determined during the ongoing VLBI observations using a “sliding window” approach. This strategy worked very well and produced a continuous dataset of dUT1 values for the whole 15-day-long campaign. Only during CONT11.07 was it not possible to derive dUT1 values since the Tsukuba telescope had to be stowed because of a typhoon.

In the second half of the year, a DBBC was installed at Onsala. In order to gain experience with the new digital system, we performed several parallel recordings with Mark IV/Mark 5A and DBBC/Mark 5B+. First fringes on all 14 S/X-channels were found by the Tsukuba correlator using Onsala DBBC/Mark 5B+ data and Tsukuba K5 data for RD.11.04 observed on June 21.

In collaboration with our colleagues in Tsukuba we observed a 12-hour long one-baseline dUT1-experiment in January. In November we observed the first three-station ultra-rapid EOP experiment, together with Tsukuba and Hobart. The observational data from Onsala and Hobart were e-transferred in real-time to the Tsukuba correlator, where the data of the three baselines were correlated and analyzed in near real-time. Again, a sliding window approach was used, and polar motion and dUT1 were determined in ultra-rapid mode, i.e. during the ongoing session.

We also participated with X-band observations in several campaigns for spacecraft navigation. We observed four sessions for the determination of the orbit of the Venus Express spacecraft and participated in one session to determine the orbit of the RadioAstron satellite.

Radio interference due to UMTS mobile telephone signals continued to be a disturbing factor for the S-band observations.

## 3. Monitoring Activities in 2011

We continued with the monitoring activities as described in previous annual reports:

### **Vertical height changes of the telescope tower**

We continued to monitor the vertical height changes of the telescope tower using the invar rod system at the 20-m telescope. The measurements are available at [wx.oso.chalmers.se/pisa/](http://wx.oso.chalmers.se/pisa/).

Table 1. VLBI observations for geodesy and space navigation at Onsala during 2011: information is given on whether the data were e-transferred in real-time (RT) and/or off-line (OL) and to which correlator, whether modules were shipped to a correlator, and whether ultra-rapid dUT1 (UR-dUT1) results were produced.

Exper.	Date	E-transfer		Module ship.	UR-dUT1	General remarks from the observations and the final correlation
		RT	OL			
R1-464	01.03	–	Bonn	–	–	OK
EUR-109	01.17	–	Bonn	–	–	OK
R1-466	01.18	–	Bonn	–	–	OK
UR-11.019	01.19	Tsuk	–	–	yes	OK, 12 h of ultra-rapid dUT1
R1-477	02.21	–	Bonn	–	–	OK, PCal problems for about 6 h
RD-11.01	02.22	Tsuk	–	Hays	yes	OK, four scans lost due to Mark 5 problems
EUR-110	03.23	–	Bonn	–	–	OK
VEX-03.25	03.25	–	JIVE	–	–	OK, Venus Express observations, 2 h
VEX-03.28	03.28	–	JIVE	–	–	OK, Venus Express observations, 2 h 45 min
VEX-03.31	03.31	–	JIVE	–	–	OK, Venus Express observations, 2 h
R1-476	03.28	–	Bonn	–	–	OK
RD-11.02	03.29	–	–	Hays	–	OK, several scans missed due to Mark 5 problems
R1-477	04.04	Tsuk	Bonn	–	yes	OK, phase-cal problems for 5 h
T2-076	05.03	–	Bonn	–	–	OK
R1-484	05.23	–	Bonn	–	–	OK, some scans lost due to Mark 5 problems
EUR-111	05.24	–	Bonn	–	–	OK, some scans lost due to Mark 5 problems
R1-488	06.20	Tsuk	Bonn	–	yes	OK
RD-11.04	06.21	Tsuk	–	Hays	yes	OK
R1-496	08.16	Tsuk	Bonn	–	yes	OK
R1-497	08.22	Tsuk	Bonn	–	yes	OK
T2-077	08.23	Tsuk	–	Hays	yes	no correlation report yet
R1-498	08.29	–	Bonn	–	–	OK
R1-500	09.12	Tsuk	–	Wash	yes	OK
C11-01	09.15	Tsuk	–	Wash	yes	OK, spurious signal in PCal for X-band Ch-2
C11-02	09.16	Tsuk	–	Wash	yes	no correlation report yet
C11-03	09.17	Tsuk	–	Wash	yes	no correlation report yet
C11-04	09.18	Tsuk	–	Wash	yes	no correlation report yet
C11-05	09.19	Tsuk	–	Wash	yes	OK, spurious signal in PCal for X-band Ch-2
C11-06	09.20	Tsuk	–	Wash	yes	no correlation report yet
C11-07	09.21	Tsuk	–	Wash	–	no correlation report yet
C11-08	09.22	Tsuk	–	Wash	yes	no correlation report yet
C11-09	09.23	Tsuk	–	Wash	yes	no correlation report yet
C11-10	09.24	Tsuk	–	Wash	yes	no correlation report yet
C11-11	09.25	Tsuk	–	Wash	yes	no correlation report yet
C11-12	09.26	Tsuk	–	Wash	yes	OK, spurious signal in PCal for X-band Ch-2
C11-13	09.27	Tsuk	–	Wash	yes	no correlation report yet
C11-14	09.28	Tsuk	–	Wash	yes	no correlation report yet
C11-15	09.29	Tsuk	–	Wash	yes	OK, spurious signal in PCal for X-band Ch-2
R1-501	10.03	Tsuk	Bonn	–	yes	OK
VEX-11.14	11.14	–	JIVE	–	–	OK, Venus Express observations, 2 h 20 min
RA-11.15	11.15	–	JIVE	–	–	OK, RadioAstron observations, 1 h 10 min
R1-509	11.28	–	Bonn	–	–	receiver/antenna problems, session lost
RD-11.06	11.29	Tsuk	Bonn	–	yes	no correlation report yet
UREOP.01	11.30	Tsuk	–	–	yes	OK, ultra-rapid EOP Onsala-Tsukuba-Hobart
RD-11.07	12.06	Tsuk	Hays	–	yes	no correlation report yet

### **Microwave radiometry**

The water vapor radiometer Astrid was in operation continuously during 2011, mainly observing in a so-called sky-mapping mode. However, after the first week of the CONT11 campaign the azimuth drive of the instrument failed, and it could only be operated in tip-curve mode. The second water vapor radiometer Konrad was successfully upgraded and is in operation again since CONT11.

### **Calibration of pressure sensor**

We continued to calibrate the Onsala pressure sensor using a Vaisala barometer borrowed from the Swedish Meteorological and Hydrological Institute (SMHI). This instrument was installed at Onsala in late 2002 and has been calibrated at SMHI's main facility in Norrköping every 1–2 years since then. The latest calibration was on October 11, 2011. Since the installation of a new VLBI pressure sensor in 2008 the agreement between the Onsala pressure sensor and the SMHI pressure sensor has been on the level of  $\pm 0.1$  hPa.

### **Sea level monitoring**

We continued to operate the GNSS-based tide gauge at the coastline at the observatory to monitor the local sea level. The tidal analysis of the sea level variations clearly shows the dominant ocean tides in the Kattegatt. In August 2011 the GNSS-based tide gauge was moved to a new location at the observatory, where it was installed semi-permanently. The new installation has a number of advantages, e.g., that the instrumentation can be mounted at different heights, in steps of 25 cm, between approximately 1.5 m and 3.5 m above the mean sea level.

### **Superconducting gravimetry**

The superconducting gravimeter (SCG) operated continuously during 2011 and produced a highly precise record of gravity variations. Of course it recorded earthquakes and free oscillations of the earth, e.g. in connection to the Sendai 2011 earthquake. Further information on the SCG and its observations is available at [froste.oso.chalmers.se/hgs/SCG/](http://froste.oso.chalmers.se/hgs/SCG/). Measurements of the auxiliary sensors for monitoring, e.g., bedrock temperature below the gravimeter house are available at [wx.oso.chalmers.se/gravimeter/](http://wx.oso.chalmers.se/gravimeter/).

### **Absolute gravimetry**

We supported visiting absolute gravity measurement campaigns by the University of Hannover (Germany) and Lantmäteriet, the Swedish mapping, cadastral and land registration authority.

### **Seismological observations**

The three-axis seismometer provided by Uppsala University and the Swedish National Seismic Network (SNSN) has been operated continuously on the lower level of the gravimeter laboratory during 2011. The recorded data are valuable auxiliary observations for the analysis of absolute gravity measurements.

## **4. Outlook**

The Onsala Space Observatory will continue to operate as an IVS Network Station and to participate in the IVS observation series. For 2012 we plan to participate in 40 IVS sessions, and we hope that we eventually can switch over to using the digital backend in operational mode. We also plan to continue our ultra-rapid project with our Japanese colleagues.

A proposal to construct a VLBI2010 twin-telescope at Onsala was submitted in 2011 to the Wallenberg foundation. A decision concerning this proposal is expected in 2012. Regardless of the outcome, we will strive to make the station fully VLBI2010-compatible in the coming years.

# Parkes 2011 IVS Report

*John Reynolds, Tasso Tzioumis*

## Abstract

This report presents the status of the Parkes Observatory in 2011, as well as our future plans.

## 1. Status

In the second full year of IVS membership the Parkes Observatory participated in six 24-hour IVS sessions, compared to just two in the previous year. These sessions were generally successful, although one session (CRDS55) was lost to an unusual recorder problem. (This problem has since resulted in an advisory circular to all stations from the Network Coordinator, headed ‘Mark 5B/B+ “,E” scan\_check problem’, 20th March 2012).

In August 2011 the Parkes S/X receiver was modified to double the available bandwidth at X-band, in order to support sessions requiring an “IF3” observing configuration. In the first of these three sessions the improvised IF3 system proved only partially successful, but it was subsequently improved for the R1507 session in November.

Parkes also continues to support a program led by Leonid Petrov (ADNET Systems/GSFC) of hybrid astronomy/geodesy observations, refining the locations of several southern hemisphere radio stations that are equipped with neither dual S/X receiving systems nor IVS-compatible recording systems. This program also aims to identify additional calibrator sources in the Southern Hemisphere for “densification” of the ICRF in the south.

## 2. Future Plans

The outlook for 2012 is a little uncertain owing to possible scheduling constraints arising from proposed changes to the Parkes Operations model that could impact the availability of the dual S/X receiver (see [http://www.atnf.csiro.au/management/atuc/2012feb/docs/carretti\\_ATUC\\_1202.pdf](http://www.atnf.csiro.au/management/atuc/2012feb/docs/carretti_ATUC_1202.pdf) for details). In 2011 these restrictions led to the participation of Parkes in IVS sessions being confined to just two blocks of time (August and November, each comprising 3 x 24hr sessions). We are working with our Australian colleagues to ensure that the S/X receiver will continue to remain available and that the active participation of Parkes in IVS observing programs will continue to be both valued and supported.

# Sheshan VLBI Station Report for 2011

*Bo Xia, Zhiqiang Shen, Xiaoyu Hong, Qingyuan Fan*

## Abstract

The Sheshan VLBI station (also named SESHAN25 in the geodetic community) is located at Sheshan, about 30 km west of Shanghai. A 25-meter radio telescope is in operation at 1.3, 3.6/13, 5, 6, and 18-cm wavelengths. The Sheshan VLBI station is a member of the IVS and EVN. The SESHAN25 telescope takes part in international VLBI experiments for astrometric, geodetic, and astrophysical research. Apart from its international VLBI activities, the telescope spent a large amount of time on the Chinese Lunar Project, including the testing before the launch of the Chang'E-2 satellite and the tracking campaign after the launch of Chang'E-2.

## 1. General Information

The Sheshan VLBI station ('SESHAN25') is located at Sheshan, 30 km west of Shanghai downtown. It is hosted by the Shanghai Astronomical Observatory (SHAO), Chinese Academy of Sciences (CAS). A 25-meter radio telescope is in operation at 1.3, 3.6/13, 5, 6, and 18 cm wavelengths. The Sheshan VLBI station is a full member of the IVS and EVN. The SESHAN25 telescope takes part in international VLBI experiments in astrometric, geodetic, and astrophysics research. Apart from its international VLBI activities, the telescope spent a large amount of time on the Chinese Lunar Project, including testing observations and the tracking campaign of Chang'E-2.

## 2. VLBI Observations in 2011

In 2011, SESHAN25 participated in 30 IVS sessions (including six INT3 Intensive sessions). SESHAN25 also participated in the EVN sessions in February, June, and October. We missed the IVS session T2077 because of an antenna motor problem. In order to participate in the Chinese Chang'E-2 Lunar Project, SESHAN25 has observed the Chang'E-2 satellite with long term routine VLBI tracking model for two or three days per week. We also missed the IVS sessions of RD1103 and R1479 during the Chang'E-2 tracking task.

## 3. Development and Maintenance of Sheshan Telescope in 2011

A new analog VLBA Terminal, which included a VLBA sampler and a VSI-C card together with a Mark 5B recorder, worked normally in our station. We solved the sampling status problems of 1 bit and 2 bit sampling respectively. After upgrading, we successfully participated in the EVN session 3 and two IVS sessions (R1512 and R1513).

We have upgraded the Mark 5A Firmware Version to 12.13 (APT 10.07, SDK 8.2). We also upgraded the Mark 5B Firmware Version to 12.06 (APT 10.07, SDK 8.2).

We also performed routine maintenance of our antenna in May of 2012.

#### 4. The Staff of the Sheshan VLBI Station

Table 1 lists the group members of the Sheshan VLBI Station. The staff are involved in the VLBI program at the station with various responsibilities.

Table 1. The staff of the Sheshan VLBI Station.

Name	Background	Position & Duty	Contact
Xiaoyu Hong	Astrophysics	Director, Astrophysics	xhong@shao.ac.cn
Qingyuan Fan	Ant. control	Chief Engineer, Antenna	qyfan@shao.ac.cn
Zhiqiang Shen	Astrophysics	Head of VLBI Division	zshen@shao.ac.cn
Zhuhe Xue	Software	Professor, FS	zhxue@shao.ac.cn
Quanbao Ling	Electronics	Senior Engineer, VLBI terminal	qling@shao.ac.cn
Bin Li	Microwave	Technical friend, receiver	bing@shao.ac.cn
Tao An	Astrophysics	Astrophysics	antao@shao.ac.cn
Bo Xia	Electronics	VLBI friend, VLBI terminal	bxia@shao.ac.cn
Hong Yu	Ant. control	Associated Professor, Antenna	yuhong@shao.ac.cn
Li Fu	Ant. mechanics	Engineer, Antenna	fuli@shao.ac.cn
Jinqing Wang	Electronics	Engineer, Antenna	jqwang@shao.ac.cn
Lingling Wang	Software	Engineer, VLBI terminal	llwang@shao.ac.cn
Rongbing Zhao	Software	Engineer, VLBI terminal	rbzhao@shao.ac.cn
Weiye Zhong	Microwave	Engineer, Receiver	wyzhong@shao.ac.cn
Wei Gou	Electronics	Engineer	gouwei@shao.ac.cn
Linfeng Yu	Electronics	Engineer	lfyu@shao.ac.cn
Yongbin Jiang	Electronics	Engineer	jyb@shao.ac.cn
Yunxia Sun	HVAC	Engineer, Refrigeration	sunyunxia@shao.ac.cn
Xiaocong Wu	Electronics	Engineer	wuxc@shao.ac.cn
Wen Guo	Electronics	Engineer	gw@shao.ac.cn
Jian Dong	Ant. Control	Engineer	dongjian@shao.ac.cn

#### 5. Outlook

In 2012 the Sheshan radio telescope will take part in 13 IVS sessions and 2 EVN sessions. The telescope will regularly monitor the Chang'E-2 satellite in its lunar orbit for 2-3 days per week in 2012.



# Geodetic and Astrophysical Study at the Simeiz VLBI Station

*A.E. Volvach*

## Abstract

This report gives an overview about the geodetic and astrophysical activities at 22-m radio telescope RT-22 (Simeiz). We summarize briefly the status of Simeiz station as an IVS Network Station.

## 1. General Information

The Simeiz VLBI Station (also known as CRIMEA in the geodetic community), operated by Radio Astronomy Laboratory of Crimean Astrophysical Observatory of the Ministry of Education and Sciences of Ukraine, is situated on the coast of the Black Sea near the village of Simeiz 20 km west of the city of Yalta in Ukraine.

RT-22, the 22-meter radio telescope, which was put into operation in 1966, is among the 10 most efficient telescopes in the world. Various observations in the centimeter and millimeter wave ranges have been performed with this telescope and will be performed in the near future. First VLBI observations were performed in 1969 on the Simeiz (RT-22) to Green Bank (RT-43, USA) intercontinental baseline. RT-22 is equipped with radiometers at the 92 cm, 18 cm, 13 cm, 6 cm, 3.5 cm, 2.8 cm, 2.3 cm, 2.0 cm, 13.5 mm, and 8 mm wavelengths.



Figure 1. Simeiz VLBI station, 22-m radio telescope RT-22.

RT-22 is a fully steerable paraboloid, 22 m in diameter, with a focal length of 9.525 m. The rms surface accuracy is 0.15 mm. The horizontal axis is shifted by  $-1.8 \pm 0.2$  mm relative to the

azimuthal axis. The operating ranges of turning angles are  $-210^\circ$  to  $210^\circ$  in azimuth and  $-3^\circ$  to  $90^\circ$  in elevation. The maximum slew rate of the antenna is  $1.5^\circ/\text{sec}$ .

RT-22 is used for multifrequency regular monitoring of active galactic nuclei; for the exploration of solar and stellar activity; for VLBI observations within the frames of international astrophysical, geophysical, and radar programs; for the exploration of water vapor, hydroxyl, methanol, and SiO cosmic masers; as well as for spectral observations in the range of frequencies from 85 GHz to 115 GHz; i.e., it is used to study the most challenging problems of modern astrophysics and natural history.

## 2. Effective Area of the Antenna of the 22-m Radio Telescope RT-22

Forty years of intensive observations with the 22-m radio telescope RT-22 CrAO and studying its characteristics at millimeter wavelengths demonstrated a fairly high quality of the instrument. Based on the results of calibrator observations at 13.5 mm and 8.2 mm wavelengths in 1985 and 2010, the dependence of the effective area of the RT-22 CrAO antenna on ambient temperature and elevation was determined. The obtained results confirm a high quality of the RT-22 antenna at millimeter wavelengths. A high accuracy of the reflector surface makes it possible to observe at millimeter wavelengths right to 2 mm. At 8.2 mm wavelength, the effective area changes by no more than 5% when the antenna is moved from zenith to  $15^\circ$  elevation angle. The effective area of the RT-22 antenna decreases by  $\sim 7\%$  when the ambient temperature deviates by  $10^\circ\text{C}$  from the value  $T_0 = 17.5^\circ\text{C}$ . Large antennas, intended to operate at maximum frequencies, should be built either taking into account the climatic conditions of the antenna sites or taking measures to provide thermal stability of the antenna.

## 3. Current Status and Activities

During 2011 the Space Geodesy and Geodynamics stations regularly participated in the following international network programs: IVS, the International GNS Service (IGS), and the International Laser Ranging Service (ILRS).

From 1 January through 31 December 2011, Simeiz VLBI station participated in twelve 24-hour geodetic sessions. Simeiz regularly participated in the EUROPE and T2 series of geodetic sessions.

The results for the RT-22 Simeiz coordinates were compared with the monthly averages of the long-term measurements of the Black Sea tide gauge stations, located in Odessa, Ochakov, Sevastopol, Yalta, and Katsively. All items of sea level measuring have a different water flow, which gives the opportunity to explore global geodynamic processes and their dependence on solar activity cycle. The spectrum of sea level variations in different points indicates the presence of periods of one to eleven and twenty-two years. Using wavelet analysis the periods for each tide gauge station are estimated separately.

Use of the Simeiz antenna is shared with the “Radioastron” program:

### 1. The catalog of sources for flight program “Radioastron”.

Observations of sample sources from the preliminary “Radioastron” catalog were obtained at 22.2 and 36.8 GHz with the RT-22 radio telescope of the Crimean Astrophysical Observatory. We have determined the distribution of the source spectral indices between these frequencies [1]. The

distributions of the spectral indices of the RT-22 sample have more important dispersion of the distribution than in the WMAP catalog (between 23 and 33 GHz) due to input parameters of sample sources from the “Radioastron” catalog. We have plotted the  $\log(10\Delta N/N_0) - \log S$  dependence down to the flux levels of about 0.1 Jy using the survey data near 22 GHz. There is a reduction in the density of cosmological sources in relation to non-evolving Euclidean universe (Figure 2). The variability of individual sources in connection with flare activity is considered.

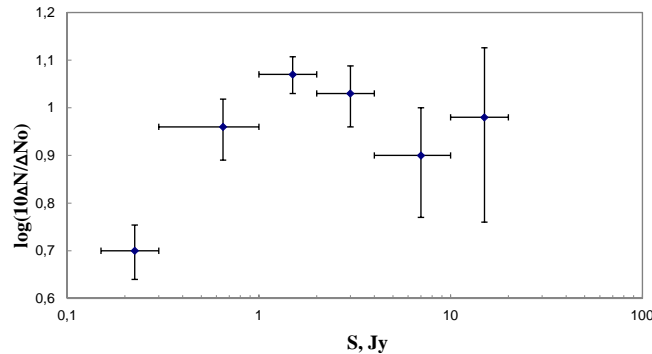

Figure 2. The differential statistical dependency  $\log N - \log S$ .

## 2. The RT-22 of CrAO: scientific program elaboration and performance of ground-based VLBI test experiments within the framework of the project “Radioastron”.

The Earth-space science program “Radioastron” includes high-resolution (microseconds of arc) studies of the morphology and dynamics of the circumnuclear regions of sources of powerful energy. In accordance with the scientific cooperation between Ukraine and Russia, the study is carried out using the 22-m radio telescope RT-22 of the Crimean Astrophysical Observatory. The research program provides the investigation with highly sensitive radiometers at frequencies of 22 GHz and 36 GHz. This makes it possible to obtain spectral characteristics of the sources near 22 GHz, which is the fundamental frequency of the experiment “Radioastron”. To realize the project, the scientific program is developed, a substantial part of which is the study of compact structures in extragalactic sources, and groundbased VLBI test experiments are conducted [2].

## 3. The testing of the ground-based segment of the “Radioastron” mission. The Simeiz - Pushchino interferometer at wavelengths of 6 and 1.35 cm.

In accordance with the scientific cooperation between Ukraine and Russia a series of studies was done for the preparation of the operation of the ground segment of the “Radioastron” mission. Using the 22-m radio telescope RT-22 (Crimean Astrophysical Observatory) the scientific program of measurements was prepared, a substantial part of which is the study of the compact structures in the extragalactic sources, as well as the structure and spatial distribution of H<sub>2</sub>O galactic masers. For testing the model of the ground segment of “Radioastron”, RT-22 of Crimean Astrophysical Observatory in Simeiz and RT-22 of the PRAO in Pushchino jointly conducted groundbased VLBI test experiments. As a result of data processing using the ASC LPI correlator the amplitude and phase of the cross-correlation functions were obtained and calibrated, and the available coherence time was estimated [3]. The results of the experiment demonstrate readiness of RT-22 (CrAO) to participate in further joint radiointerferometric sessions, including those of the “Radioastron” project. The modernization of the Simeiz station was opened up by the possibility of beginning

research of systematic and complex polarization of star forming regions.

#### 4. The testing of the ground-based segment of the “Radioastron” mission. The Simeiz - Evpatoria interferometer at wavelengths of 6 and 18 cm.

In accordance with the scientific cooperation between Ukraine and Russia a series of studies was performed for the preparation of the operation of the ground segment of the “Radioastron” mission. Using the 22-m radio telescope RT-22 the scientific program of measurements was prepared, a substantial part of which is the study of the compact structures of the extragalactic sources. For testing the model of the ground segment of “Radioastron”, RT-22 of Crimean Astrophysical Observatory in Simeiz and RT-70 (P-2500) in Evpatoria jointly conducted groundbased VLBI test experiments at 6 cm and 18 cm [4]. As a result of data processing using the ASC LPI correlator the amplitude and phase of the cross-correlation functions were obtained and calibrated, and the available coherence time was estimated (Figure 3).

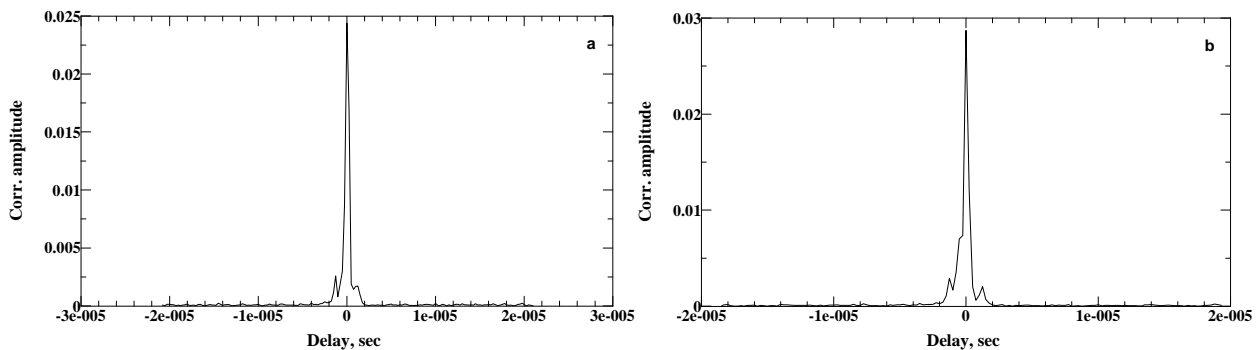

Figure 3. Simeiz-Evpatoria, 6 cm. a) 3C279,  $t=300$  sec,  $S/N > 400$  sec; b) 3C286,  $t=180$  sec,  $S/N = 440$  sec.

The results of the experiment demonstrate the readiness of RT-22 and RT-70 to participate in space-ground Very Long Baseline Interferometer sessions of the “Radioastron” project.

#### 4. Future Plans

Our plans for 2012 are the following: to put into operation the VLBI Data Acquisition System DBBC, upgrade the laser of SLR Simeiz-1873 station, and set up a new GPS station near Simeiz VLBI station.

#### References

- [1] A. E. Volvach // Space Science and Technology. 2009. T.15. N.5. P.8297.
- [2] A. E. Volvach, N. S. Kardashev, M. G. Larionov // Space Science and Technology. 2011. T.17. N.1. P.70–75.
- [3] A. E. Volvach, V. I. Kostenko, M. G. Larionov, L. N. Volvach // Space Science and Technology. 2011. T.17. N.2. P.45–50.
- [4] Volvach A. E., Kostenko V. I., Larionov M. G., Volvach L. N., et al. // Bulletin of the Crimean Astrophysical Observatory. 2012. T.108. N.1. P.1–7.

# Svetloe Radio Astronomical Observatory

*Sergey Smolentsev, Ismail Rahimov*

## Abstract

This report summarizes information on recent activities at the Svetloe Radio Astronomical Observatory in 2011. During the previous year a number of changes were carried out at the observatory to improve some technical parameters and upgrade some units to the required status. The report also provides an overview of current geodetic VLBI activities and gives an outlook for the next year.

## 1. General Information

Svetloe Radio Astronomical Observatory (Figure 1) was founded by the Institute of Applied Astronomy (IAA) as the first station of the Russian VLBI network QUASAR [1].

The sponsoring organization of the project is the Russian Academy of Sciences (RAS). The Svetloe Radio Astronomical Observatory is situated near Svetloe village in the Priozersky district of the Leningrad region (Table 1). The geographic location of the observatory is shown on the IAA RAS Web site: <http://www.ipa.nw.ru/PAGE/rusipa.htm>. The basic instruments of the observatory are a 32-m radio telescope equipped with special technical systems for VLBI observations, GPS/GLONASS/Galileo receivers, and an SLR system installed in 2011.



Figure 1. Svetloe observatory.

Table 1. Svetloe Observatory location and address.

Longitude	29°47'
Latitude	60°32'
Svetloe Observatory	
Leningrad region, Priozerski district	
188833 Russia	
rahimov@osvtl.spb.ru	

## 2. Technical Staff

Ismail Rahimov — observatory chief,  
 Tatiana Andreeva — main operator,  
 Andrey Mikhailov — FS, pointing system control.

## 3. Technical and Scientific Information

Table 2. Technical parameters of the radio telescope.

Year of construction	2000
Mount	AZEL
Azimuth range	$\pm 270^\circ$ (from south)
Elevation range	from $-5^\circ$ to $95^\circ$
Maximum azimuth	
- velocity	$1.5^\circ/\text{s}$
- tracking velocity	$1.5'/\text{s}$
- acceleration	$0.2^\circ/\text{s}^2$
Maximum elevation	
- velocity	$0.8^\circ/\text{s}$
- tracking velocity	$1.0'/\text{s}$
- acceleration	$0.2^\circ/\text{s}^2$
Pointing accuracy	better than $10''$
Configuration	Cassegrain (with asymmetrical subreflector)
Main reflector diameter	32 m
Subreflector diameter	4 m
Focal length	11.4 m
Main reflector shape	quasi-paraboloid
Subreflector shape	quasi-hyperboloid
Main reflector surface accuracy	$\pm 0.5$ mm
Frequency range	1.4–22 GHz
Axis offset	$-3.0 \pm 1.5$ mm

The electrical part of the gear and pointing system of the radio telescope was upgraded in 2008 — 2010. A new DAS R1002M designed at the IAA [2, 3] has been used in all kinds of VLBI observational programs since October 2011. The DAS R1002M is suited to work with Mark 5B and Mark 5B+ recording systems.

## 4. Co-location of VLBI, GPS/GLONASS and SLR System

The Topcon GPS/GLONASS/Galileo receiver with meteo station WXT-510 was tested and put into operation (Figure 2).



Figure 2. Topcon GPS/GLONASS/Galileo receiver at Svetloe observatory.

The SLR system “Sazhen-TM” (Figure 3) was mounted in October 2011. The “Sazhen-TM” SLR system was manufactured by Open Joint-stock Research-and-Production Corporation “Precision Systems and Instruments”. The technical parameters of the system are presented in Table 3.



Figure 3. “Sazhen-TM” SLR system at Svetloe observatory.

## 5. Current Status and Activities

The Svetloe observatory participates in IVS and domestic VLBI observational programs. During 2011 Svetloe station participated in 27 diurnal IVS-R1, IVS-R4, IVS-T2, and EURO sessions and in 17 IVS Intensive sessions.

Svetloe participated in 49 diurnal sessions in the frame of the domestic Ru-E program for determination of all Earth orientation parameters, and in 5 one-hour Ru-U sessions for obtaining Universal Time using e-VLBI data transfer.

Table 3. Technical parameters of the SLR system “Sazhen-TM”.

Ranging distance, day	400-6000 km
Ranging distance, night	400-23000 km
Aperture	25 cm
Wavelength	532 nm
Beam divergence	12''
Laser pulse frequency	300 Hz
Pulse energy	2.5 mJ
Mass	170 kg
Normal points precision	1 cm
Angular precision	1-2''

## 6. Outlook

Our plans for the coming year are the following:

- To participate in IVS observations
- To carry out domestic observational programs for obtaining Universal Time with e-VLBI data transfer and Earth orientation parameters once a week
- To carry out SLR observations of geodetic and navigation satellites
- To participate in EVN and RADIOASTRON observational sessions
- To continue geodetic monitoring of the antenna parameters.

## References

- [1] Finkelstein A., Ipatov A., Smolentsev S. The Network “Quasar”: 2008-2011 // “Measuring the future”, Proc. of the Fifth IVS General Meeting, A. Finkelstein, D. Behrend (eds.), St. Petersburg, “Nauka”, 2008. pp. 39–46.
- [2] Grenkov S. A., Nosov E. V., Fedotov L. V., Koltsov N. E. A Digital Radio Interferometric Signal Conversion System // Instruments and Experimental Techniques, 2010. Vol. 53, No. 5. pp. 675–681.
- [3] Nosov E. Next-Generation DAS for the Russian VLBI-Network. // 20th EVGA Meeting. MPIfR, Bonn. 2011. pp. 41–43.



# JARE Syowa Station 11-m Antenna, Antarctica

*Yuichi Aoyama, Koichiro Doi, Kazuo Shibuya*

## Abstract

In 2011, the 51<sup>st</sup> and the 52<sup>nd</sup> Japanese Antarctic Research Expeditions (hereinafter, referred to as JARE-51 and JARE-52, respectively) participated in six OHIG sessions, OHIG70, 71, 72, 73, 74, and 75. These data were recorded on hard disks through the K5 terminal. The hard disks for the former three sessions were brought back from Syowa Station to Japan in April 2011, by the icebreaker, Shirase, while those for the latter three sessions are scheduled to arrive in April 2012. The data obtained from the OHIG70, OHIG71, and OHIG72 sessions by JARE-51 and JARE-52 have been transferred to the Bonn Correlator via the NICT's servers. At Syowa Station, JARE-52 and JARE-53 will participate in six OHIG sessions in 2012.

## 1. General Information

With the objective of conducting studies of polar science, the National Institute of Polar Research (NIPR) is managing the Japanese Antarctic Research Expeditions (JAREs). The 30 members of JARE-52 overwintered at Syowa Station, East Ongul Island, East Antarctica in 2011.

Syowa Station has become one of the key observation sites in the Southern Hemisphere's geodetic network, as reported in [1]. As part of these geodetic measurements, the JAREs have been operating the 11-m S/X-band antenna at Syowa Station (69.0°S, 39.6°E) for geodetic VLBI experiments since February 1998. A cumulative total of 97 quasi-regular geodetic VLBI experiments had been observed by the end of 2011.

## 2. Component Description

For VLBI, the Syowa antenna is registered as IERS Domes Number 66006S004 and as CDP Number 7342. The basic configuration of the Syowa VLBI front-end system has not changed from the description in [2]. A K5 recording system was introduced at Syowa Station in September 2004. Syowa's K4 recording terminal had been fully replaced by K5 simultaneously with the termination of the SYW session at the end of 2004. Syowa has participated in the OHIG sessions in the austral summer season since 1999. Data transfer through an Intelsat satellite link from Syowa Station to NIPR has been available since 2004. However, its maximum transfer speed is about 200 kB/sec, which is too slow to be practical for the transfer of the amount of VLBI data.

## 3. Staff of the JARE Syowa Station 11-m Antenna

The 11-m S/X-band antenna at Syowa Station is operated and maintained by JARE and NIPR. The staff members are listed in Table 1. OHIG sessions in 2011 were performed primarily by the staff of JARE-52 as shown in Figure 1. The staff of JARE-51 greatly supported JARE-52 during OHIG70 – OHIG72, in order to hand the operation and maintenance of the 11-m antenna over to their successor (JARE-52).

Table 1. Staff members

Name	Affiliation	Function
Kazuo SHIBUYA	NIPR	Project coordinator
Koichiro DOI	NIPR	Liaison officer
Yuichi AOYAMA	NIPR	Liaison officer
Iuko TSUWA	University of Tokyo	Chief operator of JARE-51
Yoshinao KINJYO	NEC	Antenna engineer for JARE-51
Syunsuke IWANAMI	Tomakomai National College of Technology	Chief operator of JARE-52
Shinobu TAKAHIRA	NEC	Antenna engineer for JARE-52

JARE-51: February 2010 – January 2011

JARE-52: February 2011 – January 2012



Figure 1. Syowa VLBI staff of JARE-52, S. Iwanami (left) and S. Takahira (right).

## 4. Current Status and Activities

### 4.1. Notes on System Maintenance

The hydrogen maser (Anritsu RH401A; HM-1002C) was transported to Japan by the icebreaker Shirase in April 2011, because of the trouble with the 10 MHz output unit that occurred in December 2010. The HM-1002C was repaired and overhauled by technical experts of Anritsu and was loaded again on the Shirase in the middle of October 2011. We planned to re-install the HM-1002C at Syowa Station as the backup system. However, it was impossible to transport the HM-1002C from the Shirase to the Syowa Station, because the Shirase could not approach the Syowa Station in this austral summer season due to dense and thick sea ice. The HM-1002C will

be back in Japan in April 2012 and will be deployed at the Syowa Station again in the next austral summer.

Another hydrogen maser (Anritsu RH401A; HM-1001C) has been used for VLBI observations since January 2011. On 11 March 2011, its ion pump was interrupted by instability in both voltage and frequency of the generator for power supplies at Syowa Station. In addition, an uninterruptible power supply (UPS) for the HM-1002C broke down simultaneously. Due to a low vacuum inside the HM-1001C, the hydrogen maser oscillator was stopped. In July 2011, the staff of JARE-52 restored its high vacuum and confirmed the hydrogen maser generation. We immediately compared 1 PPS and 10 MHz signals of the HM-1001C with those of GPS using an oscilloscope, and we observed no apparent differences between the HM-1001C and GPS. The HM-1001C kept stable after its restarting.

A significant clock offset of the Syowa system was found in the correlation procedure for the OHIG68 session. This offset also appeared in the correlation procedures for the OHIG69, 70, 71, and 72 sessions, although the hydrogen maser was replaced before the OHIG70 session. We pinpointed the cause of the clock offset during preparation for the OHIG74 session. Although we had believed that the 1 PPS signal of the HM-1001C, which was synchronized with GPS 1 PPS, was being directly used as the reference of the K5 recording system, in actuality, the K5 system was referred to 1 PPS signals of the SONY DFC-1100. The DFC-1100 internally generates 1 PPS by synchronizing to HM-1001C's 1 PPS, which was the external reference. The staff of JARE-53 found a warning of this synchronization system of DFC-1100 on November 8, 2011. The synchronization system had probably failed since February 2010. The clock delay of DFC-1100's 1 PPS in comparison with GPS was about 700 msec measured with the oscilloscope. After resetting the synchronization system, the clock delay became insignificant. However, we changed an arrangement of 1 PPS signal cables on November 8 as follows: 1 PPS signal cables from HM-1001C were connected to DFC-1100 and directly to K5 system; 1 PPS signal cable from DFC-1100 was connected to the HP universal counter for checking the clock offset in comparison with GPS.

## 4.2. Session Status

Table 2 summarizes the status of processing as of December 2011 for the sessions after 2008. The OHIG sessions involved Fortaleza (Ft), O'Higgins (Oh), Kokee Park (Kk), Parkes (Pa), TIGO Concepción (Tc), Hobart 26-m antenna (Ho), Hobart 12-m antenna (Hb), HartRAO (Hh), Warkworth (Ww), and Syowa (Sy). In 2005, Syowa joined the CRD sessions, but after 2006, Syowa participated only in OHIG sessions. Syowa took part in six OHIG sessions in 2011.

Until 2004, K4 tapes containing the OHIG sessions' data from Syowa Station were copied to Mark IV tapes at GSI, and the Mark IV tapes were sent to the Mark IV Correlator for final correlation. Since the introduction of the K5 system, K5 hard disk data brought back from Syowa Station have been transferred by ftp to the MIT Haystack Observatory or the Bonn Correlator through a NICT server and converted to the Mark 5 format there.

## 4.3. Analysis Results

As of December 2011, Syowa had contributed 88 sessions from May 1999. Among them, 77 sessions up to February 2011 had been analyzed with the software CALC/SOLVE developed by NASA/GSFC. According to the result analyzed by the BKG IVS Analysis Center, the length of the Syowa-Hobart baseline is increasing with a rate of  $55.0 \pm 0.8$  mm/yr. The Syowa-HartRAO

Table 2. Status of OHIG sessions as of December 2011.

Code	Date	Station	Hour	Correlation	Solution	Notes
OHIG62	2009/Feb/04	Ft, Ho, Kk, Oh, Tc	24 h	Yes	Yes	J50
OHIG63	2009/Feb/10	Ft, Ho, Kk, Oh, Tc	24 h	Yes	Yes	
OHIG64	2009/Feb/11	Ft, Ho, Kk, Oh, Tc	24 h	Yes	Yes	
OHIG65	2009/Nov/10	Ho, Kk, Oh, Tc	24 h	Yes	Yes	
OHIG66	2009/Nov/11	Ho, Kk, Oh, Tc	24 h	Yes	Yes	
OHIG67	2010/Feb/03	Ft, Kk, Oh, Tc	24 h	Yes	Yes	
OHIG68	2010/Feb/09	Ft, Ho, Kk, Oh, Tc, Hb	24 h	Yes	Yes	
OHIG69	2010/Feb/10	Ft, Ho, Kk, Oh, Tc, Hb	24 h	Yes	Yes	
OHIG70	2011/Feb/02	Hb, Hh, Ho, Kk, Oh, Tc	24 h	Yes	Yes	J52
OHIG71	2011/Feb/08	Hb, Hh, Kk, Oh, Tc	24 h	Yes	Yes	
OHIG72	2011/Feb/09	Hh, Kk, Oh, Tc	24 h	No	No	
OHIG73	2011/Nov/01	Ft, Kk, Ww	24 h	–	–	
OHIG74	2011/Nov/08	Ft, Kk, Tc, Ww	24 h	–	–	
OHIG75	2011/Nov/09	Ft, Kk, Tc, Ww	24 h	–	–	

J50: JARE-50, op Y. Murakami eng Y. Yamaguchi J51: JARE-51, op I. Tsuwa eng Y. Kinjyo

J52: JARE-52, op S. Iwanami eng S. Takahira

baseline shows a slight increase in its length with a rate of  $11.1 \pm 0.9$  mm/yr. These results agree approximately with those of GPS. The Syowa–O’Higgins baseline also shows a slight increase, although its rate is only  $2.1 \pm 1.0$  mm/yr. Detailed results from the data until the end of 2003 as well as comparisons with those from other space geodetic techniques were reported in [3].

## 5. Future Plans

NIPR has already started to discuss how to remove the Syowa VLBI antenna during December 2015 – February 2016. Therefore, we must make a concrete plan and obtain a budget for replacing the Syowa antenna within a few years.

## References

- [1] Shibuya, K., Doi, K., and Aoki, S. (2003): Ten years’ progress of Syowa Station, Antarctica, as a global geodesy network site. *Polar Geoscience*, 16, 29-52.
- [2] Shibuya, K., Doi, K., and Aoki, S. (2002): JARE Syowa Station 11-m Antenna, Antarctica, in *International VLBI Service for Geodesy and Astrometry 2002 Annual Report*, 149-152, NASA/TP-2003-211619, ed. by N. R. Vandenberg and K. D. Baver.
- [3] Fukuzaki, Y., Shibuya, K., Doi, K., Ozawa, T., Nothnagel, A., Jike, T., Iwano, S., Jauncey, D.L., Nicolson, G.D., and McCulloch, P.M. (2005): Results of the VLBI experiments conducted with Syowa Station, Antarctica. *J. Geod.*, 79, 379-388.

# Status and Developments at TIGO Concepción

*Cristian Herrera, Felipe Pedreros, Octavio Zapata, Hayo Hase*

## Abstract

The main activities at the TIGO VLBI station during 2011 have been the successful observation of 121 VLBI sessions enabling post-earthquake monitoring, the development of a VLBI control software for smartphones, encoder replacement, and beamsize analysis measurements.

## 1. General Information

The operation of TIGO is based on an agreement between the Republic of Chile and the Federal Republic of Germany. The following three institutions are responsible for the actual activities: Universidad de Concepción (UdeC, Chile), Instituto Geográfico Militar (Chile), and Bundesamt für Kartographie und Geodäsie (BKG, Germany). TIGO is located on a tract of land of UdeC (73.025°W, 36.843°S) in Concepción, Chile. Due to financial problems of UdeC, the TIGO project was threatened with termination by the end of 2011. A temporary financial aid from BKG allows for the continued operation in 2012.

## 2. Component Description

The IVS Network Station TIGOCONC constitutes the VLBI part of the Geodetic Observatory TIGO, which was designed as a fundamental station for geodesy. Hence, the VLBI radio telescope is co-located with an SLR telescope (ILRS site), a GPS/Glonass receiver (IGS site), and other instruments such as a seismometer, a superconducting gravimeter, and an absolute gravity meter. The atomic clock ensemble of TIGO consists of three hydrogen masers, three cesium clocks, and four GPS time receivers realizing the Chilean contribution to the Universal Time scale (Circular T, BIPM). The technical parameters of the TIGO radio telescope published in [1] have not changed.

## 3. Staff

The 2011 VLBI staff consisted of four persons (see Table 1). At the beginning of 2011, three

Table 1. TIGO VLBI staff in 2011. Email addresses are `firstname.lastname@tigo.cl` for individuals and `vlbistaff@tigo.cl` for all VLBI operators.



Staff	Function
Hayo Hase	Head
Cristian Herrera	Informatic Engineer
Felipe Pedreros	Telecommunications Engineer
Octavio Zapata	Telecommunications Engineer

(from left) Herrera, Zapata, Pedreros, and Hase.

former staff members (Sergio Sobarzo, Eric Oñate, and Pedro Zaror) left; their positions could not be refilled due to financial problems at UdeC.

#### 4. Current Status and Activities

During 2011 TIGO was scheduled to participate in 124 regular IVS sessions plus 15 additional sessions of the CONT11 campaign. Twelve 24-hour experiments were carried out within the TANAMI project [2]. Table 2 gives an overview of the participation of TIGOCONC in 2011. Out of the 136 requested observation days, 121 could be observed successfully, reaching an efficiency of 89%. The main reason for the experiment failures was a technical problem in the vacuum system of the dewar in April 2011. The replacement of the waveguide window and the vacuum valve became necessary. The lack of these spare parts at TIGO and the delay for delivery caused the loss of several experiments.

Table 2. TIGO's IVS observation statistics for 2011.

Name	R1xxx	R4xxx	OHIGxx	T2	RD	TANAMI	CONT11	Total IVS
# of Exp.	48	48	5	2	6	12	15	<b>136</b>
Success	42	40	5	2	5	12	15	<b>121</b>
Failure	6	8	0	0	1	0	0	<b>15</b>

##### 4.1. Post-earthquake Monitoring

Two years after the M8.8 earthquake, the TIGOCONC coordinates still show post-seismic activity. Figure 1 depicts the coordinate time series for TIGOCONC (relative to the first session) for the period 2002–2012; the insets display the post-earthquake coordinate behavior. The post-seismic velocity vector points to the West, while the pre-seismic velocity vector pointed to the North-East.

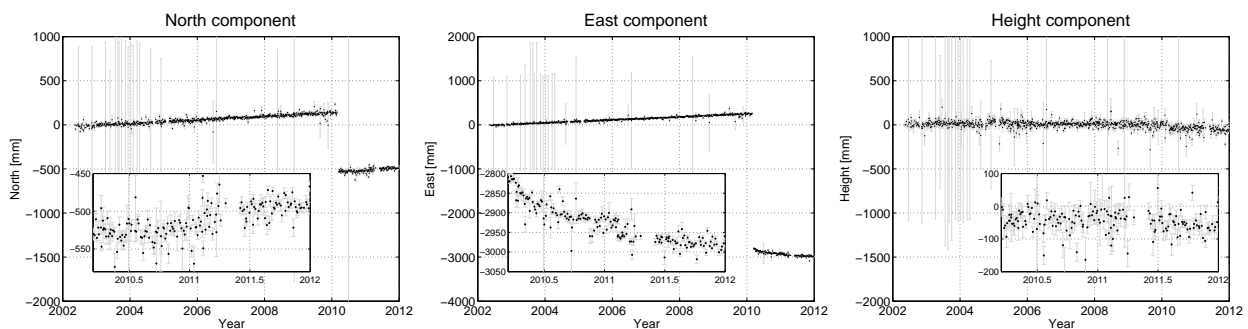

Figure 1. TIGOCONC coordinate time series showing pre- and post-earthquake displacements in the North, East and Up components. The biggest change is still active in the East component. (Time series courtesy of Gerald Engelhardt, BKG.)

### 4.2. Elevation Encoder Replacement

During 2011 the elevation servo control showed small jumps in the elevation axis of the telescope without causing an emergency stop. Several warning messages about this behavior appeared in the log files. Since the amplitude of these periodical jumps were only on the order of 0.01 degrees, the observations were not affected by significant pointing errors. After ruling out many potential error sources through tests, the problem was identified as missing bits in the elevation encoder. Consequently, the encoder was replaced by a spare which resolved the problem. Figure 2 presents screen shots from the diagnosis computer showing the elevation encoder signal during tracking before and after the exchange of the encoder.

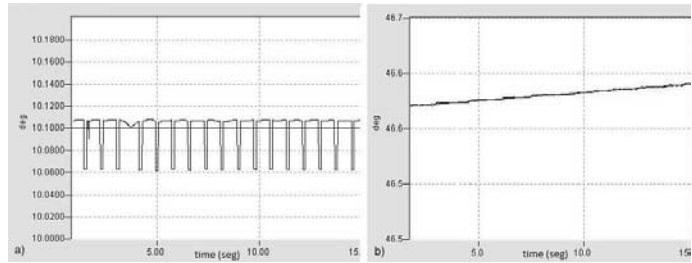

Figure 2. Screen shots from the diagnosis computer of the elevation encoder signal during tracking before (left) and after (right) the encoder replacement.

### 4.3. Beam Pattern and Sidelobe Detection Measurements

In collaboration with undergraduate students of UdeC, work was done to characterize the beam pattern of the 6-m telescope [3]. For the first part of the investigation two RF sources (2.3 GHz

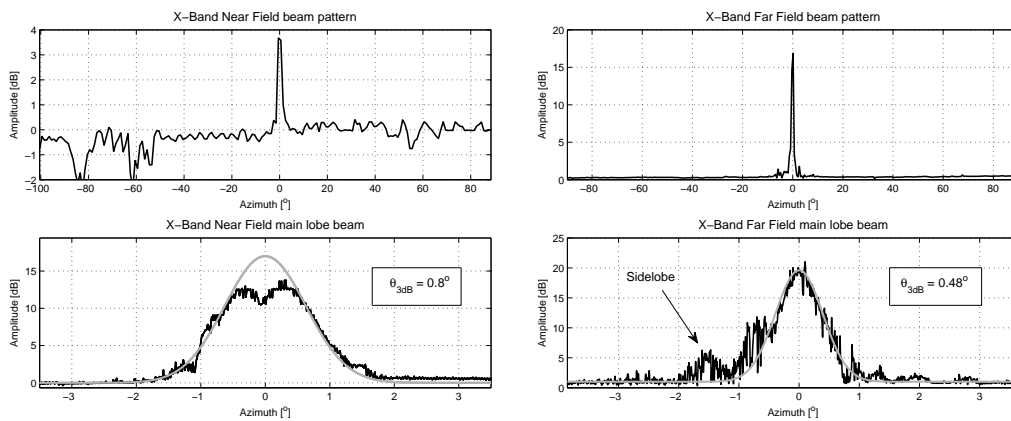

Figure 3. Beam patterns in the near field (left) and far field (right) measured at 8.4 GHz.

and 8.4 GHz) were placed at a distance of 115 m from the telescope. Using a raster scan technique, the variation of the received power was measured at the square law detectors in the two baseband converters. Then the background noise was measured (with the RF sources off) and subtracted from the data. Figure 3 (left) shows the main beam and a wide scan beam pattern, looking for sidelobes in X band. However, the results obtained are not a true representation of the beam, since the distance between the source and the receiver is in the near field of the telescope and very likely affected by ground reflections. In the second part of the investigation, the RF source was

located beyond the Rayleigh distance for X band ( $\sim 2$  km). The geography allowed placement of the RF source at an elevated height (20 m above the observatory level) at a distance of 2.84 km. The direct line of sight crossed a valley therefore reducing ground reflections. The same previous scanning and acquisition strategy was used. Figure 3 (right) shows the far field main beam and the wide beam pattern for X band. The main beam was fitted with a Gaussian function. Results show that the measured 3dB beamwidth  $\theta_{3dB} = 0.48^\circ$  is larger than the theoretical value for an X-band 6-m aperture antenna ( $0.36^\circ$ ). In addition a sidelobe near  $1.5^\circ$  from the center has been detected at a level of  $\sim 15$ dB below the maximum.

#### 4.4. Smartphone Monitor Application

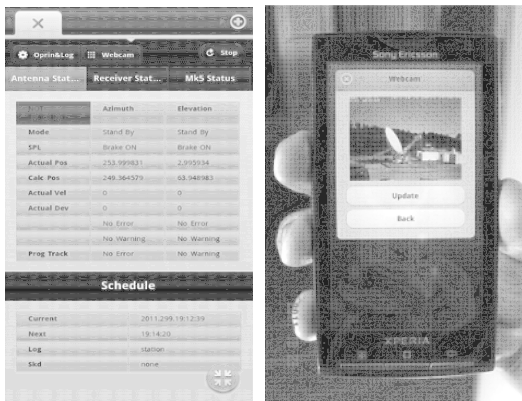

Figure 4. (left) A screen shot of the smartphone software with Antenna Control Unit and the current schedule. (right) Webcam of the radio telescope in the interface of the smartphone software for VLBI experiments.

Due to a shortage of operators it was necessary to control the running of VLBI sessions from elsewhere. For the remote control and monitoring of VLBI operations a software optimized for smartphones was developed by Cristian Herrera. This is a new tool based on a client-server architecture with a Web interface optimized for smartphone screens and cellphone networks. The server uses variables of the Field System and its station specific parameters stored in shared memory. The client running on the smartphone by a Web interface analyzes and visualizes the current status of the radio telescope, receiver, schedule, and recorder. In addition, it allows the sending of commands remotely to the Field System computer and displays the log entries. The software also integrates a webcam interface. It was tested successfully in many sessions during 2011, and it can be adapted to other VLBI stations.

#### 5. Future Plans

The VLBI activities in 2012 will focus on the execution of the IVS observation program, upgrading from the Mark 5A recorder to Mark 5B+, and tests of e-VLBI transfer.

#### References

- [1] Vandenberg, N. R.: International VLBI Service for Geodesy and Astrometry 2000 Annual Report, NASA/TP-1999-209243, 1999.
- [2] M. Kadler, R. Ojha, S. Tingay and J. Lovell, *The TANAMI Program: Southern-Hemisphere VLBI Monitoring of Relativistic Jets in Active Galaxies*, American Astronomical Society, AAS Meeting #211, #04.13; Bulletin of the American Astronomical Society, Vol. 39, p. 732.
- [3] F. Pedreros, H. Pacheco, H. Hase, *Beam pattern characterization of the 6 m TIGO telescope*, Poster presented at the 7th IVS General Meeting, Madrid, Spain, 2012.



## Tsukuba 32-m VLBI Station

*Ryoji Kawabata, Shinobu Kurihara, Kensuke Kokado, Yoshihiro Fukuzaki, Jiro Kuroda,  
Misao Ishihara, Yasuko Mukai, Takashi Nishikawa*

### Abstract

The Tsukuba 32-m VLBI station is operated by the Geospatial Information Authority of Japan (hereafter GSI). This report summarizes the activities of the Tsukuba 32-m VLBI station in 2011.

Over 200 sessions were observed with the Tsukuba 32-m and other GSI antennas in accordance with the IVS Master Schedule of 2011. The Tsukuba 32-m could not participate in the IVS sessions for nearly one month due to the 2011 earthquake that occurred off the Pacific Coast of Tohoku and the following aftershocks which occurred in March. Fortunately, the Tsukuba 32-m had no serious damage and came back to IVS observing on April 4.

### 1. General Information

The Tsukuba 32-m VLBI station is located at GSI in Tsukuba Science City which is about 50 km to the northeast of the capital Tokyo (Figure 1). GSI has three regional stations besides TSUKUB32: SINTOTU3, CHICHI10, and AIRA, which form the Geodetic VLBI network in Japan covering the whole country (Figure 2).

GSI has carried out the domestic VLBI session series called “JADE (Japanese Dynamic Earth observation by VLBI)”. The main purposes of the JADE series are to define the reference frame of Japan and to monitor the plate motions for the advanced study of crustal deformations. Additionally, Mizusawa (VERAMZSW) and Ishigakijima (VERAISGK), which are part of the VERA network of the National Astronomical Observatory of Japan (NAOJ), have also participated in the JADE sessions.



Figure 1. Tsukuba 32-m VLBI station.

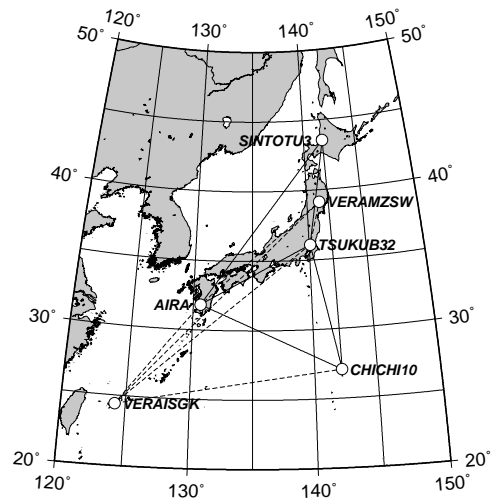

Figure 2. Geodetic VLBI network in Japan.

## 2. Component Description

The specifications of the Tsukuba 32-m antenna are summarized in Table 1.

Table 1. Tsukuba 32-m antenna specifications.

Owner and operating agency	Geospatial Information Authority of Japan
Year of construction	1998
Radio telescope system	Az-El
Antenna design	Cassegrain
Diameter of main reflector	32 m
Azimuth range	10 – 710°
Elevation range	5 – 88°
Az/El drive velocity	3°/sec
Tsys at zenith (X/S)	50 K / 75 K
SEFD (X/S)	320 Jy / 360 Jy
RF range (X1)	7780 – 8280 MHz
RF range (X2)	8180 – 8680 MHz
RF range (X3)	8580 – 8980 MHz
RF range (S with BPF)	2215 – 2369 MHz
Recording terminal	K5/VSSP32, ADS3000+ with DBBC

## 3. Staff

Table 2 lists the regular operating staff belonging to the GSI VLBI observation group. In December 2011, Yoshihiro Fukuzaki re-joined our group in order to investigate and determine the specifications of the new station for VLBI2010, which will be installed near Tsukuba as mentioned in Section 5.

Routine operations were mainly performed under contract with Advanced Engineering Service Co., Ltd. (AES). Daisuke Tanimoto resigned from our group at the end of March. To replace him, Takashi Nishikawa became a new member in June.

Table 2. Staff list of the GSI VLBI group.

Name	Position/Company	Function
Misao ISHIHARA	Director of Space Geodesy Div.	Supervisor
Jiro KURODA	Deputy Director of Space Geodesy Div.	Management, Co-location
Yoshihiro FUKUZAKI	Technical Officer	Specification of VLBI2010 system
Shinobu KURIHARA	Chief of Very Long Baseline Sec.	Responsible official, IVS DB member
Kensuke KOKADO	Chief of Baseline Analysis Sec.	Correlation, Analysis, Data transfer
Ryoji KAWABATA	Very Long Baseline Sec.	VLBI operation, miscellaneous work
Kazuhiro TAKASHIMA	Chief Researcher of Space Geodesy Research Div.	Research
Yasuko MUKAI	AES, Co., Ltd.	Observation
Takashi NISHIKAWA	AES, Co., Ltd.	Observation and Correlation
Toshio NAKAJIMA	I-JUSE	System engineer

## 4. Current Status and Activities

### 4.1. Geodetic VLBI Observations

The regular sessions in the IVS Master Schedule carried out by GSI antennas are shown in Table 3. TSUKUB32 participated in 88 domestic and international 24-hr VLBI sessions and 116 Intensive 1-hr sessions for dUT1 measurement in this year. SINTOTU3, CHICHI10, and AIRA participated not only in domestic sessions but also in some international sessions.

Table 3. The number of regular sessions carried out by GSI antennas in 2011. The numbers in parentheses show those of canceled sessions listed in the IVS Master Schedule.

Sessions	TSUKUB32	SINTOTU3	CHICHI10	AIRA
IVS-R1	44(3)	–	–	–
IVS-T2	6(1)	–	6(1)	5(2)
APSG	2	2	2	0(2)
VLBA	6	–	–	–
IVS-R&D	6(1)	–	–	–
CONT	15	–	–	–
JADE	8	7	4	3(2)
JAXA	1	–	1	1
IVS-INT2	79(1)	–	–	–
IVS-INT3	37(1)	–	–	–
Total	204(7)	9	13(1)	9(6)

### 4.2. The 2011 Earthquake Off the Pacific Coast of Tohoku

On March 11, a massive earthquake with a moment magnitude of 9.0 hit Japan, and we experienced a severe shake in Tsukuba. The elevation drive gear of the Tsukuba 32-m shook from side to side due to the earthquake. Nevertheless, the antenna and other observation devices had no serious damage, though some computer displays fell from the desks in the building of the observatory.

Many aftershocks following the main earthquake continued for nearly one month. Therefore we decided to stop the observation of the Tsukuba 32-m until the beginning of April, since we were afraid that the antenna might have serious damage caused by the aftershocks. The Tsukuba 32-m returned to IVS observing on April 4. These sessions enabled us to determine the new position of the Tsukuba 32-m, and we found large co- and post-seismic displacements of Tsukuba.

### 4.3. Ultra Rapid dUT1 Experiments in CONT11

The Tsukuba 32-m participated in the CONT11 campaign from September 15 to 29. We transferred the data of the Tsukuba 32-m to the Tsukuba correlator via high-speed network. The data of the Onsala Space Observatory in Sweden was also transferred via high-speed network to the Tsukuba correlator and converted to the K5 data format in near real-time. Then both data sets were correlated and analyzed automatically. This was the first success for us to obtain continuous ultra rapid dUT1 values during 15 days, though the observation of the Tsukuba 32 meter was interrupted for nearly one day due to a typhoon which struck Tsukuba during the CONT11 campaign. The details of the results are shown in the annual report of the Tsukuba

analysis center.

#### **4.4. Co-location Survey of the Tsukuba 32-m**

From June through July, we performed field surveys in order to measure the relative vector of the reference points of the Tsukuba 32-m and TSKB, which is the IGS point in Tsukuba. We needed 10 intermediate points in order to determine the relative vector of the Tsukuba 32-m and TSKB, since the distance between the two points is approximately 300 m. We determined the relative vector of two points with precisions of 3.0 mm horizontally and 0.9 mm vertically as a preliminary result. Further analysis is in progress.

#### **5. VLBI2010 Project in GSI**

We obtained a budget for surveys of the RFI environment and the underground condition at the candidate sites for a VLBI2010 station. We checked the radio interference in two candidate sites and will survey the underground condition by March 2012.

Moreover we obtained a special budget for the installation of a VLBI2010 station, which includes antenna, feed, receiver, data recorder, hydrogen masers, and operation building. Our group has investigated and discussed the specifications of the new system for VLBI2010 and prepared some documents for the installation of the new station. Construction of the new station will be completed by the end of March 2013.

# Nanshan VLBI Station Report for 2011

*Aili Yusup, Xiang Liu, Zhang Ming*

## Abstract

The Nanshan 25-meter radio telescope is operated by Xinjiang Astronomical Observatory. This report describes the activities and the status of the Nanshan VLBI station as an IVS network station in 2011.

## 1. Introduction

The Nanshan VLBI station is located 70 km south of Urumqi, the capital city of the Xinjiang Uygur Autonomous Region of China. The station is affiliated with the Xinjiang Astronomical Observatory of the National Astronomical Observatories of CAS. In 2011, we participated in a total of 230 domestic and international VLBI sessions and contributed to IVS in geodetic VLBI observations. The Nanshan VLBI station has participated in domestic VLBI experiments as one of the VLBI ground stations tracking the Chinese Chang'E satellite. In addition, a GPS station, as a part of the IGS network, is located near the VLBI telescope.



Figure 1. The Nanshan station, Xinjiang Astronomical Observatory, NAOC, CAS.

## 2. Telescope Status

### 2.1. Antenna

- Diameter: 25-meter
- Antenna type: Modified Cassegrain
- Seat-rack type: Azimuth-pitching ring
- Main surface precision: 0.40 mm (rms)
- Pointing precision: 15'' (rms)
- Rolling range: Azimuth:  $\pm 270^\circ$ ; Elevation:  $5^\circ$  to  $88^\circ$
- Maximum rolling speed: Azimuth:  $1.0^\circ/\text{sec}$ ; Elevation:  $0.5^\circ/\text{sec}$



Figure 2. The 25-m, modified Cassegrain radio telescope of the Xinjiang Astronomical Observatory.

### 2.2. Receivers

The basic specifications of the receivers and the antenna sensitivities are given in Table 1. The new 1.3 cm dual cooling receiver was installed in 2011.

Table 1. Specifications of receivers.

Parameters				Freq. Range (MHz)
1.3 cm	dual	Tsys= 45K	DPFU=0.08	22000–24200
3.6 cm	RCP	Tsys= 60K	DPFU=0.093	8100–8900
6 cm	dual	Tsys= 22K	DPFU=0.11	4700–5110
13 cm	RCP	Tsys= 50K	DPFU=0.096	2150–2450
18 cm	dual	Tsys= 24K	DPFU=0.088	1400–1720
30 cm	LCP	Tsys=160K	DPFU=0.06	800–1200

### 2.3. Recording Systems

The recording systems available at the Nanshan VLBI station are Mark 5B, Mark IV, Mark II, and K5. The performance of the observing system was improved in the report year. The Field System has been upgraded to version 9.10.4, and it works well. The DBBC system, which was built at Shanghai Observatory (SHAO), was installed at Urumqi for domestic VLBI observations with the Mark 5B recorder. The traditional BBC system is still being used for international VLBI observations together with the Mark 5B recorder.

### 2.4. Time and Frequency System

There are three H-masers at the Nanshan Station: the MHM2010 imported from Symmetricom company of the U. S. plus the No. 13 and No. 90 H-masers made in Shanghai. The time and frequency comparison system operates continuously.

## 3. IVS Observations in 2011

Seven IVS sessions were scheduled for the Nanshan VLBI station in 2011. We participated in all seven of these sessions. The details are listed in Table 2.

Table 2. IVS sessions scheduled for the Nanshan VLBI station in 2011.

Experiment	Date	Remarks (problems)
T2075	03.22	Observed
T2076	05.05	Observed, no problems
APSG28	07.28	Observed, no problems
APSG29	08.17	Observed, no problems
T2077	08.23	Observed, began 22:17 (UT)
T2078	10.11	Observed, no problems
T2079	11.28	Observed, no problems

#### 4. Personnel

The main staff of the Nanshan VLBI station is compiled in Table 3.

Table 3. The main staff of the Nanshan VLBI station.

Name	Position	Working area	e-mail
Na Wang	Professor	Station chief	na.wang@uao.ac.cn
Aili Yusup	Professor	Chief engineer	aliyu@uao.ac.cn
Xiang Liu	Professor	VLBI friend	liux@uao.ac.cn
Maozheng Chen	Senior engineer	Receiver	mzchen@uao.ac.cn
Ming Zhang	Scientist	Astronomy	zhangming@uao.ac.cn
Wenjun Yang	Engineer	Terminal	yangwj@uao.ac.cn
Shiqiang Wang	Engineer	Antenna	Wangshq@uao.ac.cn
Hua Zhang	Engineer	Terminal, Time and Freq.	zhangh@uao.ac.cn
Guanghai Li	Engineer	Network, Computer	ligh@uao.ac.cn
Jun Ma	Engineer	Receiver	majun@uao.ac.cn
Chenyu Chen	Engineer	Antenna	chency@uao.ac.cn
Jun Nie	Scientist	Network, Computer	niejun@uao.ac.cn
Mingshuai Li	Engineer	Time and Freq.	limingsh@uao.ac.cn



# Warkworth 12-m VLBI Station: WARK12M

*Stuart Weston, Hiroshi Takiguchi, Tim Natusch, Sergei Gulyaev*

## Abstract

The Warkworth 12-m Radio Telescope is operated by the Institute for Radio Astronomy and Space Research (IRASR) at AUT University, Auckland, New Zealand. This report briefly reviews the characteristics of the 12-m VLBI station. We report on a number of technical developments; integration of the station DBBC with the Field System pointing algorithm, installation of a MET4 weather sensor and an experimental phase calibration system. We discuss work being done to improve the determination of ocean tide loading effects for the site and report on efforts to develop the capability to participate in EOP experiments.



Figure 1. Warkworth 12-m (left) and Warkworth 30-m (right) antennas at the AUT's Warkworth Radio Astronomical Observatory. Photo: Sergei Gulyaev.

## 1. Station Equipment and Characteristics

The WARK12M radio telescope is located some 60 km north of the city of Auckland, near the township of Warkworth (Figure 1) [1]. Specifications of the Warkworth 12-m antenna are provided in Table 1. The radio telescope is equipped with an S/X dual-band dual-circular polarization feed. Backend data digitizing is handled by a digital base band converter (DBBC) developed by the Italian Institute of Radio Astronomy. The station frequency standard is a Symmetricom Active Hydrogen Maser MHM-2010 (75001-114). Mark 5B+ and Mark 5C data recorders are used for data storage and streaming of recorded data off site by computer network. The radio telescope is directly connected to the regional network KAREN (Kiwi Advanced Research and Education Network) via a 1 Gbps fiber link to the site [2].

## 2. Technical Developments

### 2.1. DBBC Integration with Field System

Software has been written that allows the Field System pointing routines (fivept, onoff, and acquire) to access power measurements from the DBBC. The TCP socket interface to the DBBC

Table 1. Specifications of the Warkworth 12-m antenna.

Antenna type	Dual-shaped Cassegrain
Manufacturer	Cobham/Patriot, USA
Main dish Diam.	12.1 m
Secondary refl. Diam.	1.8 m
Focal length	4.538 m
Surface accuracy	0.35 mm
Pointing accuracy	18''
Frequency range	1.4—43 GHz
Mount	alt-azimuth
Azimuth axis range	$90^\circ \pm 270^\circ$
Elevation axis range	$4.5^\circ$ to $88^\circ$
Azimuth axis max speed	$5^\circ/\text{s}$
Elevation axis max speed	$1^\circ/\text{s}$
Main dish F/D ratio:	0.375

control program is used for this inter-device communication. With this new capability we have been able to dramatically improve the pointing of Wark12M and finally obtain reasonable results in X band. Further work in this area is planned that will result in the determination of SEFD,  $T_{\text{sys}}$ , and Gain curves for the telescope.

## 2.2. MET4 Meteorological Sensor

Properly calibrated data on local atmospheric conditions is now available following the installation of a MET4 sensor at the telescope site. At present the MET4 directly connects to the station Field System computer via an RS 232 physical interface. With optimization of the measurements in mind an RS 485 interface is currently being investigated that would allow the sensor to be positioned in closer proximity to the antenna and further away from the influence of buildings and other structures. Data from the MET4 is continuously monitored and automatically written into the Field System log for IVS experiments. It is anticipated that this data will be used to improve the compensation for atmospheric effects at the station.

## 2.3. E-transfer

We have made extensive use of our connection via KAREN (Kiwi Academic Research Education Network) to international research networks for data transfers to correlators. In the last year only one diskpack, bound for Haystack, was physically shipped. Considerable savings on shipping costs have been realized as a result of this capability. We have used Tsunami, gridFTP, and UDT protocols as appropriate for the requirements of the correlator site to which we are sending data [3, 4].

## 2.4. Experimental Phase Calibration System

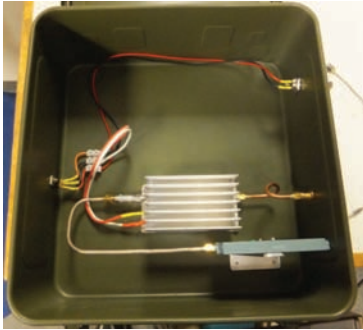

Figure 2. Experimental phase calibration system.

By kind offer from the National Institute of Information and Communications Technology, Kashima Space Research Center, we installed an experimental phase calibration system which was assembled by NICT on the 12-m antenna. The unit is fed a 5 MHz signal from the station Maser, and its output is coupled into the antenna feed by 30 dB loop couplers located immediately prior to the LNA in both S and X band paths (Figure 2).

After considerable engineering effort it has been possible to adjust the phase calibration signal level observed at the backend of the receivers to suitable levels. Phase calibration signals have been detected in both S and X band channels using K5 software [5].

We have carried out fringe tests on the WARK12M-KASHIM11 baseline several times, finally obtaining fringes and succeeding with bandwidth synthesis and analysis of the data (Figure 3).

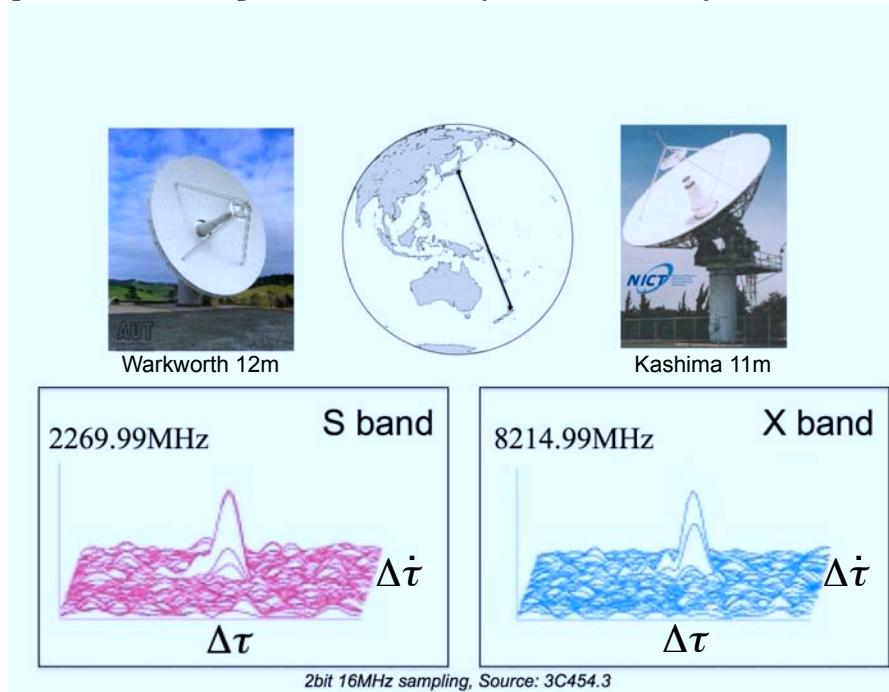

Figure 3. Warkworth 12-m (left) and Kashima 11-m (right) baseline. The fringes of this baseline for both S and X band are presented.

## 2.5. Improving the Determination of Ocean Tide Loading Effects

We are preparing appropriate models for our station to use in geodetic analysis. Firstly we checked the ocean tide loading effects and determined that the coastline data used by the Ocean

Tide Loading Provider [6] is not sufficiently accurate for our station. Therefore, we have constructed a more accurate coastline model from SRTM (the Shuttle Radar Topography Mission) [7] data sets. We calculated the site-dependent tidal coefficients of the 11 main tides by using GOTIC2 software [8] with this new coastline data. To compare the result we obtained the standard tidal coefficients from the Ocean Tidal Loading provider. The differences of the ocean tidal loading displacement at Warkworth calculated from both site-dependent tidal coefficients were about  $\pm 1$  mm in the horizontal components and  $\pm 2$  mm in the vertical component, respectively (Figure 4). These differences are large compared with our aim of 1 mm accuracy for baseline measurements. As a next step we are going to apply this result to geodetic analysis and evaluate the effect.

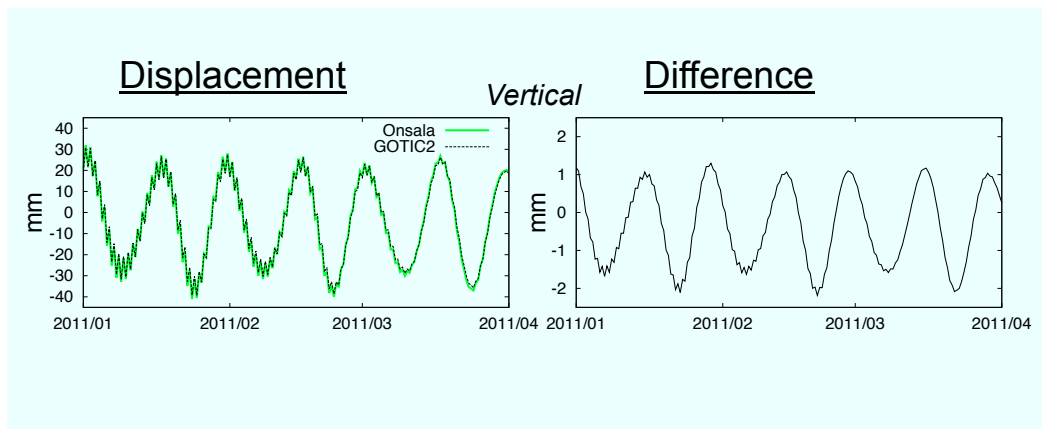

Figure 4. The ocean tidal loading displacement (vertical) at Warkworth in millimeters (left) and the difference between two OTL models (right).

## References

- [1] Takiguchi, H., S. Gulyaev, T. Natusch, S. Weston, and L. Woodburn, Towards Synergy of VLBI and GNSS Geodetic Techniques in Geologically Dynamic New Zealand, *Advances in Geosciences*, 2012. (in press)
- [2] Weston, S., Natusch, T., Gulyaev, S., Radio Astronomy and e-VLBI using KAREN. *In Proceedings of the 17th Electronics New Zealand Conference*, 2010. Preprint arXiv:1011.0227.
- [3] Wagner, J., Tsunami UDP Protocol. Available online: <http://tsunami-udp.sourceforge.net>
- [4] Gu, Y., UDT: A High Performance Data Transport Protocol (Unpublished doctoral dissertation). University of Illinois, Chicago, USA, 2005. See also <http://udt.sourceforge.net/doc/udt-2009.ppt>
- [5] Kondo, T., Y. Koyama, R. Ichikawa, M. Sekido, E. Kawai, and M. Kimura, Development of the K5/VSSP System, *J. Geodetic Soc. Japan*, **54**(4), 233-248, 2008.
- [6] <http://froste.oso.chalmers.se/loading/index.html>
- [7] Farr, T. G., et al., The Shuttle Radar Topography Mission, *Rev. Geophys.*, **45**, RG2004, doi:10.1029/2005RG000183, 2007.
- [8] Matsumoto, K., T. Sato, T. Takanezawa, and M. Ooe, GOTIC2: A Program for Computation of Oceanic Tidal Loading Effect, *J. Geod. Soc. Japan*, **47**, 243-248, 2001.

# Westford Antenna

*Mike Poirier*

## Abstract

Technical information is provided about the antenna and VLBI equipment at the Westford site of the Haystack Observatory and about changes to the systems since the IVS 2010 Annual Report.

## 1. Westford Antenna at Haystack Observatory

Since 1981 the Westford antenna has been one of the primary geodetic VLBI sites in the world. Located  $\sim 70$  km northwest of Boston, Massachusetts, the antenna is part of the MIT Haystack Observatory complex.



Figure 1. The radome of the Westford antenna.

Table 1. Location and addresses of the Westford antenna.

Longitude	71.49° W
Latitude	42.61° N
Height above m.s.l.	116 m
MIT Haystack Observatory	
Off Route 40	
Westford, MA 01886-1299 U.S.A.	
<a href="http://www.haystack.mit.edu">http://www.haystack.mit.edu</a>	

The Westford antenna was constructed in 1961 as part of the Lincoln Laboratory Project West Ford that demonstrated the feasibility of long-distance communication by bouncing radio signals off a spacecraft-deployed belt of copper dipoles at an altitude of 3600 km. In 1981 the antenna was converted to geodetic use as one of the first two VLBI stations of the National Geodetic Survey Project POLARIS. Westford has continued to perform geodetic VLBI observations on a regular

basis since 1981. Westford has also served as a test bed in the development of new equipment and techniques now employed in geodetic VLBI worldwide. Funding for geodetic VLBI at Westford is provided by the NASA Space Geodesy Program.

## 2. Technical Parameters of the Westford Antenna and Equipment

The technical parameters of the Westford antenna, which is shown in Figure 2, are summarized in Table 2.

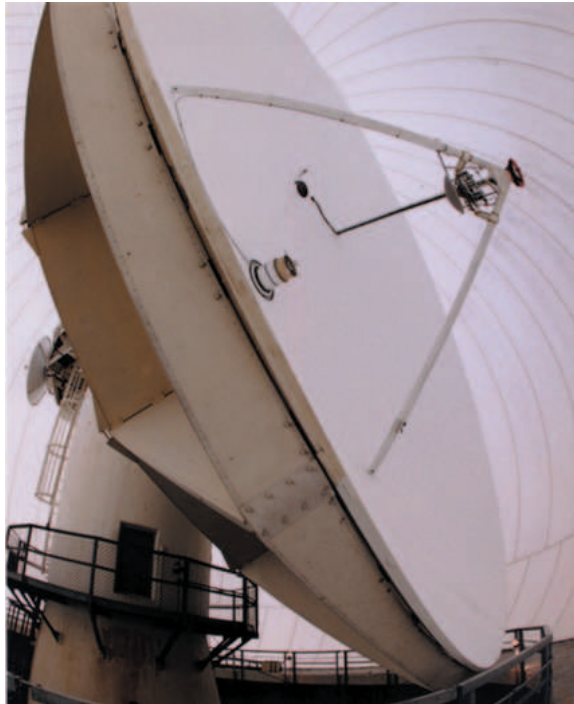

Figure 2. Wide-angle view of the Westford antenna inside the radome. The VLBI S/X receiver is located at the prime focus. The subreflector in front of the receiver is installed when observing with the TAL receiver (see Section 4), which is located at the Cassegrain focus.

The antenna is enclosed in a 28-meter diameter air-inflated radome made of 1.2 mm thick Teflon-coated fiberglass—see Figure 1. When the radome is wet, system temperatures increase by 10–20 K at X-band and by a smaller amount at S-band. The major components of the VLBI data acquisition system are a Mark IV electronics rack, a Mark 5B recording system, and a Pentium-class PC running PC Field System version 9.10.2. The primary frequency and time standard is the NR-4 hydrogen maser. A CNS Clock GPS receiver system provides a 1 pps reference clock to which the maser 1 pps is compared.

Westford also hosts the WES2 GPS site of the IGS network. A Dorne-Margolin chokering antenna is located on top of a tower ~60 meters from the VLBI antenna, and a LEICA GRX1200 Reference Station receiver acquires the GPS data.

Table 2. Technical parameters of the Westford antenna for geodetic VLBI.

<i>Parameter</i>	<i>Westford</i>	
primary reflector shape	symmetric paraboloid	
primary reflector diameter	18.3 meters	
primary reflector material	aluminum honeycomb	
S/X feed location	primary focus	
focal length	5.5 meters	
antenna mount	elevation over azimuth	
antenna drives	electric (DC) motors	
azimuth range	90° – 470°	
elevation range	4° – 87°	
azimuth slew speed	3° s <sup>-1</sup>	
elevation slew speed	2° s <sup>-1</sup>	
	<i>X-band system</i>	<i>S-band system</i>
frequency range	8180-8980 MHz	2210-2450 MHz
$T_{sys}$ at zenith	50–55 K	70–75 K
aperture efficiency	0.40	0.55
SEFD at zenith	1400 Jy	1400 Jy

### 3. Westford Staff

The personnel associated with the geodetic VLBI program at Westford and their primary responsibilities are:

Chris Beaudoin	broadband development
Joe Carter	antenna controls
Brian Corey	VLBI technical support
Kevin Dudevoir	pointing system software
Dave Fields	technician, observer
Glenn Millson	observer
Arthur Niell	principal investigator
Michael Poirier	site manager
Alan Whitney	site director

### 4. Standard Operations

From January 1, 2011 through December 31, 2011, Westford participated in 46 standard 24-hour sessions and in the 15 day CONT geodetic session. Westford regularly participated in IVS-R1, IVS-R&D, and RD-VLBA observations.

Use of the Westford antenna is shared with the Terrestrial Air Link (TAL) Program operated by the MIT Lincoln Laboratory. In this project Westford serves as the receiving end on a 42-km long terrestrial air link designed to study atmospheric effects on the propagation of wideband communications signals at 20 GHz.

## 5. Research and Development

In its role as a test bed for VLBI developments, the Westford antenna was implemented several times during the year with the VLBI2010 broadband feed assembly and used successfully as the second element of the interferometer with the GGAO 12-m VLBI2010 system.

The antenna was also equipped with the Mark 6 prototype data recorder for a demonstration of 16 Gbps recording capability. The equipment has been left in place for additional Mark 6 testing and development.

## 6. Outlook

Westford is expected to participate in 61 24-hour sessions in 2012. We also plan to have the flexibility to support occasional fringe tests, e-VLBI experiments, and the continuing VLBI2010 broadband development program.



# Geodetic Observatory Wettzell - 20-m Radio Telescope and Twin Telescope

*Alexander Neidhardt, Gerhard Kronschnabl, Raimund Schatz*

## Abstract

In 2011 the 20-m radio telescope at the Geodetic Observatory Wettzell, Germany contributed again very successfully to the IVS observing program. Technical changes, developments, improvements, and upgrades have been made to increase the reliability of the entire VLBI observing system. In parallel the mechanical assembly of the new Twin radio telescope (TTW) was finished while the HF-receiving system was constructed.

## 1. General Information

The 20-m radio telescope in Wettzell (RTW) is an essential component of the Geodetic Observatory Wettzell (GOW) and is jointly operated by Bundesamt für Kartographie und Geodäsie (BKG) and Forschungseinrichtung Satellitengeodäsie (FESG) of the Technische Universität München (Technical University Munich). In addition to the RTW, GOW also operates an ILRS laser ranging system, several IGS GPS permanent stations, a large laser gyroscope G (ringlaser), and the associated local techniques such as time and frequency, meteorology and super conducting gravity meter. Currently also the first fully VLBI2010-compliant Twin telescope is being built on location. It should extend the observation possibilities according to the new technical suggestions of the IVS Working Group 3 (WG3).

Within the responsibility of the GOW are also the TIGO system in Concepción, Chile, operated mainly together with the Universidad de Concepción (see separate report about TIGO), and the German Antarctic Receiving Station (GARS) O'Higgins in Antarctica, operated together with the German Space Center (DLR) and the Institute for Antarctic Research Chile (INACH) (see separate report about O'Higgins).

## 2. Staff

The staff of the GOW consists in total of 34 members (excluding students) for operations, maintenance, repair work, and the improvement and development of the systems. The staff operating RTW are in Table 1. One additional engineer is on a position which is funded by the "Novel EXploration Pushing Robust e-VLBI Services" (NEXPREs) project in cooperation with the Max-Planck-Institute for Radioastronomy (MPIfR), Bonn. It was also possible to support the student operators to work within development projects and internships.

## 3. Observations in 2011

The 20-m RTW has supported the geodetic VLBI activities of the IVS and partly those of other partners, such as the EVN, for over 25 years. All successfully observed sessions in the year 2011 are summarized in Table 2. After the repair of the bearings the RTW once again observes in all sessions and, except for some problems with the gears and the servo system, which are also dated, the telescope is in a very good and stable state. The main priority for operations was

Table 1. Staff members of RTW.

Name	Affiliation	Function	Mainly working for
Johannes Ihde	BKG	interim head of the GOW (until February 2011)	GOW
Ullrich Schreiber	BKG	head of the GOW (since March 2011)	GOW
Alexander Neidhardt	FESG	head of the RTW group and VLBI station chief	RTW, TTW (partly O'Higgins, laser ranging)
Erhard Bauernfeind	FESG	mechanical engineer	RTW
Ewald Bielmeier	FESG	technician	RTW
Gerhard Kronschnabl	BKG	electronic engineer	RTW, TTW (partly TIGO and O'Higgins)
Christian Plötz	BKG	electronic engineer	O'Higgins, RTW
Raimund Schatz	FESG	software engineer	RTW
Walter Schwarz	BKG	electronic engineer	RTW (partly O'Higgins and WVR)
Reinhard Zeitlhöfler	FESG	electronic engineer	RTW
Martin Ettl	FESG/MPIfR	IT and computer scientist	NEXPreS
Thomas Guggeis	FESG/BKG	student (January to September 2011)	RTW, project work, WLRS
Yvonne Klingl	FESG/BKG	student (May to December 2011)	WLRS, RTW, project work
Daniel Prexler	FESG/BKG	student (May to December 2011)	WLRS, RTW, project work
Martin Riederer	FESG/BKG	student (January to March 2011)	RTW, project work
Johannes Vogl	FESG/BKG	student (January to December 2011)	RTW, project work, WLRS

the participation in all daily one-hour INTENSIVE sessions (INT) in order to determine UT1-UTC. For these sessions the complete data transfer is done electronically (e-transfer). RTW now routinely uses the increased Internet connection capacities of 1 Gbit/sec for the e-transfers to Bonn, Tsukuba, and Haystack. Following the implementation of a Field System extension for remote control, weekend INTENSIVES were partly done in the new observation modes of remote attendance, remote control from students at the laser ranging system (WLRS), or completely unattended.

In addition to the standard sessions, RTW also observed fifteen CONT11 sessions of the IVS within a network of thirteen stations in September 2011. During the CONT11 campaign all stations ran observations continuously over a period of fifteen days. Within these days the RTW had only dropouts of a few minutes. The data were saved on Mark 5A (standard) and as backup on Mark 5B+ or EVN PC hard drive. In addition, the RTW staff also operated the TIGO VLBI telescope remotely during the Chilean night shifts, using the e-RemoteCtrl software from Wettzell. Other special observations were done for Digital Baseband Converter (DBBC) tests and for spacecraft tracking. Within these additional one-hour observations the ESA Venus Express and Mars express spacecraft were observed at X-band with the Wettzell radio telescope using a framework of the assessment study for possible contributions in the European VLBI network to the upcoming ESA deep space missions.

#### 4. Technical Improvements and Maintenance

During the report period usual maintenance work had to be done. Regularly, tasks and maintenance days (obtaining replacements for the hardware, 8-pack repair, gear maintenance, Field System updates, cryo system maintenance, servo replacements, and improvements by using EVN-PCs for e-VLBI issues) were scheduled for this work. Especially the exchange of motors in elevation and azimuth after reaching their lifetime must be mentioned. Another very important work was to

Table 2. RTW observations in 2011.

program	number of 24h-sessions	program	number of 1h-sessions
IVS R1	50	INT1(Koee-RTW)	229
IVS R4	49	INT2/K(Tsukuba-RTW)	153
IVS T2	7	INT3/K(Tsukuba-RTW-NyAl)	40
IVS R&D	7	<b>total (in hours)</b>	<b>422</b>
RDV/VLBA	5	<b>special program</b>	<b>in hours</b>
EUROPE	6	VENUS Express /	
CONT11	15	MARS Express	9
<b>total</b>	<b>139</b>	<b>total (in hours)</b>	<b>18</b>
<b>total (in hours)</b>	<b>3336</b>		

derust, prime, and paint the metal parts of the cabin, the feed cone, and the legs of the subreflector support. The work was done during observation gaps and the final cleanup of the large repair of the bearings. After several problems with the servo system, it became necessary to work on some relays and to clean up the gear motor and the break adapter. The components of the servo system are dated and not available on the market anymore. Similar changes had to be done to the Mark IV data acquisition rack.

A first change from Mark 5A to Mark 5B and Mark 5B+ was possible, by changing the Mark IV formatter to support the new VSI-interface. Within a student project, a Mark IV VSI version of the formatter was programmed, developing VHDL for a Xilinx-FPGA using the Xilinx-Software “ISE”. The developed software runs on a specially designed VSI-formatter board. It was tested during integration tests and CONT11. Parallel to this development all Mark 5 systems were upgraded and updated.

The usage of the EVN-PC for e-transfer was continuously extended. In addition, the installation and test usage of the new Digital Baseband Converters (DBBC) were advanced. They should replace the existing analog video converters and formatter of the Mark IV-rack. They should provide the basis for a higher data rate with better data quality in a fully digital way, in particular for the VLBI2010 system. Wettzell is one of the main test sites for the DBBC. In cooperation with the developers at HATLab, MPIfR and INAF, new DBBC components were tested, calibrated, and adjusted. Several test data were correlated at the Bonn Correlator to check the functionality and quality. The development is still under way.

The remote control software “e-RemoteCtrl” was also extended mainly by the TUM. In close cooperation with the developers of the NASA Field System and with other test sites, new features were established. Some sites (e.g., the new AuScope network in Australia) already use the software routinely. During CONT11 the software was used to control the TIGO VLBI telescope remotely by the night shifts. The development is funded in Task 3 of Work Package 5 of the NEXPreS Project and is performed in cooperation with MPIfR. An appropriate authentication, a dedicated role management for different user types, different remote access states to shared telescopes, system monitoring, and sophisticated graphical user interfaces are under development.

## 5. The TWIN Radio Telescope Wettzell (TTW)

The Twin Telescope Wettzell project is Wettzell’s realization of a fully VLBI2010-compliant radio telescope. With the design and construction being the main focus, the buildings could be



Figure 1. The telescopes of Wettzell: the 20-m radio telescope during CONT11 and the new TWIN radio Telescope Wettzell (TTW).

finished in 2011. Therefore, at the beginning of 2011 a lot of factory approvals were made (e.g., of the sub-reflector and servo systems). Also the construction of the control building was completed (coordinated with the Staatliche Bauamt Regensburg).

In detail the following items were performed:

- A photogrammetric survey of the reflector surface was made in June. It included the adjustment of the sub-reflector at an elevation of 58 degrees. The adjusting optimizes the wavelength error.
- The TWIN is now in the geodetic survey of the observatory.
- All mechanical installations and assemblies were finished successfully in August. Therefore the telescopes are now fully maneuverable.
- An optimization of the servo system was started according to the local conditions.
- The construction of the multiband coaxial horn for S-, X-, and Ka-band and the corresponding dewar is in the final stage at the companies Mirad (feed) and Callisto (dewar). The second feed of the Eleven feed type for 2 to 14 GHz is under development at the company Omnisys.
- The computer and server room was populated with water cooled racks.
- The development of the new receivers is in progress in Wettzell. Several student projects to implement single parts of them were carried out very successfully.

## 6. Plans for 2012

For 2012, dedicated plans are:

- Regular usage of the digital baseband converters (DBBC)
- Continue NEXPreS
- Develop the front end parts of the Twin telescopes
- Finalize one of the Twin telescopes

## Instituto Geográfico Nacional of Spain

*Francisco Colomer, Susana García–Espada, Jesús Gómez–González,  
José Antonio López–Fernández, Pablo de Vicente*

### Abstract

This report updates the description of the space geodesy facilities of the Spanish National Geographic Institute (IGN). The current 40-m radio telescope at Yebes, a network station for IVS, has performed geodetic VLBI observations regularly since September 2008. In addition to this, the project to establish an Atlantic Network of Geodynamical and Space Stations (RAEGE) is progressing with the construction of the first antenna, to be erected in Yebes in 2012.

### 1. General Information: the IGN Facilities at Yebes

Yebes Observatory, a department of the Instituto Geográfico Nacional (IGN, Ministerio de Fomento), holds two radio telescopes: the new 40-m which is a network station for IVS, and the old 14-m used between 1995 and 2003. Yebes Observatory is also the reference station for the Spanish GNSS network and holds permanent facilities for gravimetry. The RAEGE project will provide a new VLBI2010-type antenna in Yebes as soon as 2012. An SLR system in a new control building will also be built in the near future.

### 2. IGN Staff Working on VLBI Projects

Table 1 lists the IGN staff who are involved in space geodesy studies and operations. The VLBI activities are also supported by other staff such as receiver engineers, computer managers, secretaries, and students. In 2011, the process of hiring dedicated telescope operators was finally concluded, increasing the operational efficiency of the instrument also for its participation in geodetic VLBI campaigns.

Table 1. Staff in the IGN VLBI group (e-mail: [vlbitech@oan.es](mailto:vlbitech@oan.es)).

Name	Background	Role	Address*
Francisco Colomer	Astronomer	VLBI Project coordinator	IGN
Susana García–Espada	Engineer	geoVLBI expert	CAY
Jesús Gómez–González	Astronomer	Deputy Director for Astronomy, Geodesy and Geophysics	IGN
José Antonio López–Fdez	Engineer	Yebes site manager	CAY
Javier López–Ramasco	Geodesist	Geodesist	CAY
Alvaro Santamaría	Geodesist	Geodesist	CAY
Pablo de Vicente	Astronomer	VLBI technical coordinator	CAY

#### Addresses:

**IGN:** Instituto Geográfico Nacional. Calle General Ibañez de Ibero 3, E–28003 Madrid, Spain.

**CAY:** Centro Astronómico de Yebes. Apartado 148, E–19080 Guadalajara, Spain.

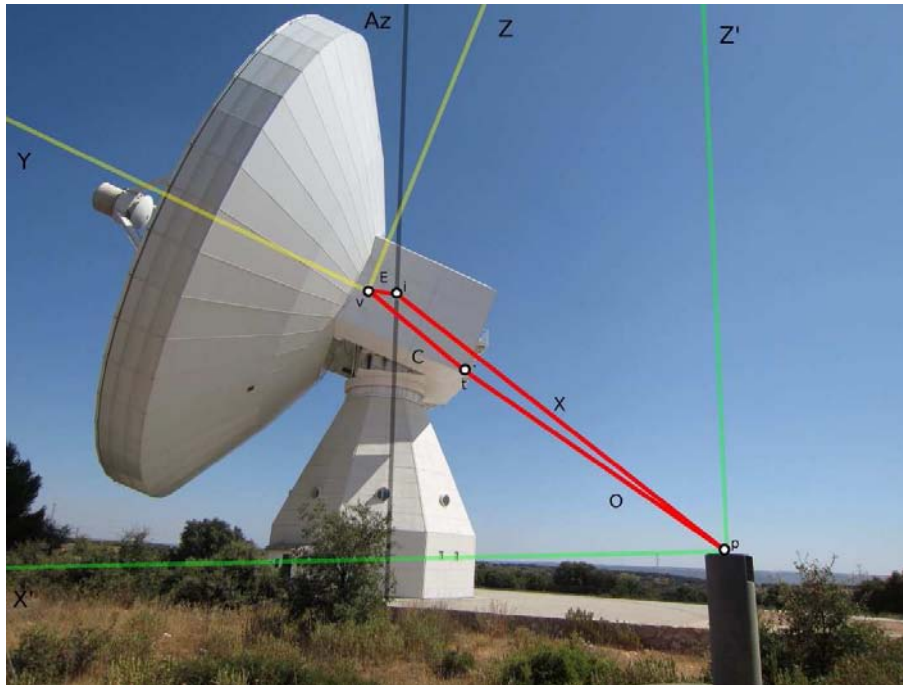

Figure 1. Geometric approach to determine the location of the Invariant Reference Point of the 40-m radio telescope at Yebes observatory.

### 3. Status of Geodetic VLBI Activities at IGN

The 40-m radio telescope has participated in 21 sessions of the EURO, R4, and T2 series as well as in the whole CONT11 campaign on September 15-30, 2011.

The studies of the tropospheric effect caused by neutral atmosphere continues in cooperation with the geodesy group at Onsala Space Observatory in Sweden, by using the HIRLAM 3D-VAR numerical weather prediction model; the slant delay caused by the neutral atmosphere is calculated via ray-tracing (see García-Espada, Haas and Colomer 2011).

A simulation has been produced to assess to what extent an automatic system based on robotic total stations could be properly configured to continuously monitor the Invariant Reference Point of the 40-m radio telescope at the Yebes observatory, using a geometric model that improves the classical 3D circle fitting methods. This approach is able not only to accurately estimate the IRP coordinates and other parameters (e.g., eccentricity and non-orthogonality of the axes), but also it allows monitoring of its temporal behavior, thus providing fundamental information about the radio telescope deformation. Indeed, one robotic total station would allow reliable estimation of the IRP coordinates in 24h observation batches, provided that the precision of the observed target coordinates is better than 1 cm (see Santamaría-Gómez and García-Espada 2011).

A new high-speed Internet connection has been built to connect Yebes to GÉANT. Running at 1 Gbps since April 2009, the new dark fiber will allow data transfer of 10 Gbps starting in 2012.

Figure 2 shows the new gravimeter pavillion, which permanently holds an absolute gravimeter and a GWR superconducting gravimeter installed in May 2010.



Figure 2. The A10 absolute and GWR superconducting gravimeters installed in a dedicated building in Yebes. (Figure courtesy of Carlos Albo Castaño, IGN).

#### 4. Project RAEGE

As mentioned in the previous report, IGN (together with the Portuguese colleagues in DSCIG) is constructing a network of four new Fundamental Geodynamical and Space Stations in Spain and Portugal (Azores Islands). The project, named *RAEGE* (after “**R**ed **A**tlántica de **E**staciones **G**eodinámicas y **E**spaciales”), consists of the erection of one radio telescope of VLBI2010 class (i.e., of 13.2-m diameter, having a high slew rate, and capable of operating in the 2-14 GHz bands but also up to 90 GHz), a permanent GNSS receiver, and a gravimeter in Yebes, Tenerife (Canary Islands), Santa María and Flores (Azores Islands), and an SLR station in Yebes (see e.g. Gómez-González et al. 2011).

The construction of three antennas, to be installed in Yebes, Azores (Santa María), and Canary Islands, and contracted to MT Mechatronics (Germany), has started (see Figure 3). The first antenna will be erected in Yebes in 2012, shortly followed by the antenna in Santa María.

Radio frequency interference (RFI) has been monitored at Yebes and the other chosen sites, demonstrating that in the latter cases the spectrum in the bands of interest is very clean.

Meanwhile, preliminary studies, concerning the installation of a Satellite Laser Ranging system in Yebes, have started (see Vaquero Jiménez and López Fernández 2011).



Figure 3. RAEGE telescopes under construction in Spain. Left: receiver cabins. Right: antenna counterweights.

## References

- [1] García-Espada S., Haas R., Colomer F. “Application of ray-tracing through the high resolution numerical weather model HIRLAM for the analysis of European VLBI data”. In Procs. 20<sup>th</sup> European VLBI working meeting for Geodesy and Astrometry (EVGA). Bonn (Germany), 2011.
- [2] Gómez-González J., Assis M. C. S., Colomer F., J. A., López Fernández J. A. “An Atlantic Network of Geodynamical and Space Stations (Project RAEGE)”. In Procs. European Geosciences Union General Assembly 2011. Vienna (Austria), 2011 (see <http://meetingorganizer.copernicus.org/EGU2011/EGU2011-8026.pdf>).
- [3] Santamaría-Gómez A., García-Espada S. “Simulating the estimation of the 40-m radio telescope Invariant Reference Point at the Yebes Observatory”. Informe Técnico OAN 2011-9 (see <http://www1.oan.es/informes/archivos/IT-OAN-2011-9.pdf>).
- [4] Vaquero Jiménez B., López Fernández J. A. “CYLAR Specifications (CDT Yebes Laser Ranging)”. Informe Técnico OAN 2011-11 (see <http://www1.oan.es/informes/archivos/IT-OAN-2011-11.pdf>).
- [5] de Vicente P., García-Espada S. “Testing the VLBI system prior to the CONT11 campaign”. Informe Técnico OAN 2011-6 (see <http://www1.oan.es/informes/archivos/IT-OAN-2011-6.pdf>).
- [6] de Vicente P., Bolaño R., Almendros C. “DBBC installation and tests at the 40-m radio telescope”. Informe Técnico OAN 2011-8 (see <http://www1.oan.es/informes/archivos/IT-OAN-2011-8.pdf>).



# Zelenchukskaya Radio Astronomical Observatory

*Sergey Smolentsev, Andrei Dyakov*

## Abstract

This report summarizes information on recent activities at the Zelenchukskaya Radio Astronomical Observatory in 2011. During the previous year a number of changes were carried out at the observatory to improve some technical parameters and upgrade some units to required status. The report also provides an overview of current geodetic VLBI activities and gives an outlook for the next year.

## 1. General Information

Zelenchukskaya Radio Astronomical Observatory (Figure 1) was founded by the Institute of Applied Astronomy (IAA) as one of three stations of the Russian VLBI network QUASAR [1]. The sponsoring organization of the project is the Russian Academy of Sciences (RAS). The Zelenchukskaya Radio Astronomical Observatory is situated in Karachaevo-Cherkesskaya Republic (the North Caucasus) about 70 km south of Cherkessk, near to the Zelenchukskaya village. The geographic location of the observatory is shown on the IAA RAS Web site: <http://www.ipa.nw.ru/PAGE/rusipa.htm> (Table 1). The basic instruments of the observatory are a 32-m radio telescope equipped with special technical systems for VLBI observations, GPS/GLONASS/Galileo receivers, and an SLR system installed in 2011.



Figure 1. Zelenchukskaya observatory.

## 2. Technical Staff

Andrei Dyakov — observatory chief,  
Dmitry Dzuba — FS, pointing system control,  
Anatoly Mishurinsky — front end and receiver support.

Table 1. Zelenchukskaya Observatory location and address.

Longitude	41°34'
Latitude	43°47'
Zelenchukskaya Observatory	
Karachaevo-Cherkesskaya Republic	
369140, Russia	
ipazel@mail.svkchr.ru	

### 3. Technical and Scientific Information

Table 2. Technical parameters of the radio telescope.

Year of construction	2000
Mount	AZEL
Azimuth range	$\pm 270^\circ$ (from south)
Elevation range	from $-5^\circ$ to $95^\circ$
Maximum azimuth	
- velocity	$1.5^\circ/\text{s}$
- tracking velocity	$1.5'/\text{s}$
- acceleration	$0.2^\circ/\text{s}^2$
Maximum elevation	
- velocity	$0.8^\circ/\text{s}$
- tracking velocity	$1.0'/\text{s}$
- acceleration	$0.2^\circ/\text{s}^2$
Pointing accuracy	better than $10''$
Configuration	Cassegrain (with asymmetrical subreflector)
Main reflector diameter	32 m
Subreflector diameter	4 m
Focal length	11.4 m
Main reflector shape	quasi-paraboloid
Subreflector shape	quasi-hyperboloid
Main reflector surface accuracy	$\pm 0.5$ mm
Frequency range	1.4–22 GHz
Axis offset	$-3.0 \pm 1.5$ mm

The electrical part of the gear and pointing system of the radio telescope was upgraded in 2008 — 2010. A new DAS R1002M designed at the IAA [2, 3] has been used in all kinds of VLBI observational programs since October 2011. The DAS R1002M is suited to work with Mark 5B and Mark 5B+ recording systems.

#### 4. Co-location of VLBI, GPS/GLONASS and SLR System

The Topcon GPS/GLONASS/Galileo receiver with meteo station WXT-510 was tested and put into operation (Figure 2).



Figure 2. Topcon GPS/GLONASS/Galileo receiver at the Zelenchukskaya observatory.

The SLR system “Sazhen-TM” (Figure 3) was mounted in May 2011. The “Sazhen-TM” SLR system was manufactured by Open Joint-stock Research-and-Production Corporation “Precision Systems and Instruments”. The technical parameters of the system are presented in Table 3.



Figure 3. “Sazhen-TM” SLR system at Zelenchukskaya observatory.

Table 3. Technical parameters of the SLR system “Sazhen-TM”.

Ranging distance, day	400-6000 km
Ranging distance, night	400-23000 km
Aperture	25 cm
Wavelength	532 nm
Beam divergence	12''
Laser pulse frequency	300 Hz
Pulse energy	2.5 mJ
Mass	170 kg
Normal points precision	1 cm
Angular precision	1-2''

## 5. Current Status and Activities

The Zelenchukskaya observatory participates in IVS and domestic VLBI observational programs. During 2011 Zelenchukskaya station participated in 49 diurnal IVS sessions — IVS-R1, IVS-R4, IVS-T2, IVS-R&D, EURO, and CONT11.

Zelenchukskaya participated in 49 diurnal sessions in the frame of the domestic Ru-E program for determination of all Earth orientation parameters and in 55 one-hour Ru-U sessions for obtaining Universal Time using e-VLBI data transfer.

## 6. Outlook

Our plans for the coming year are the following:

- To participate in IVS observations
- To carry out domestic observational programs for obtaining Universal Time with e-VLBI data transfer and Earth orientation parameters once a week
- To carry out SLR observations of geodetic and navigation satellites
- To participate in EVN and RADIOASTRON observational sessions
- To continue geodetic monitoring of the antenna parameters.

## References

- [1] Finkelstein A., Ipatov A., Smolentsev S. The Network “Quasar” : 2008-2011 // “Measuring the future”, Proc. of the Fifth IVS General Meeting, A. Finkelstein, D. Behrend (eds.), St. Petersburg, “Nauka”, 2008. pp. 39–46.
- [2] Grenkov S. A., Nosov E. V., Fedotov L. V., Koltsov N. E. A Digital Radio Interferometric Signal Conversion System // Instruments and Experimental Techniques, 2010. Vol. 53, No. 5. pp. 675–681.
- [3] Nosov E. Next-Generation DAS for the Russian VLBI-Network. // 20th EVGA Meeting. MPIfR, Bonn. 2011. pp. 41–43.

# Operation Centers

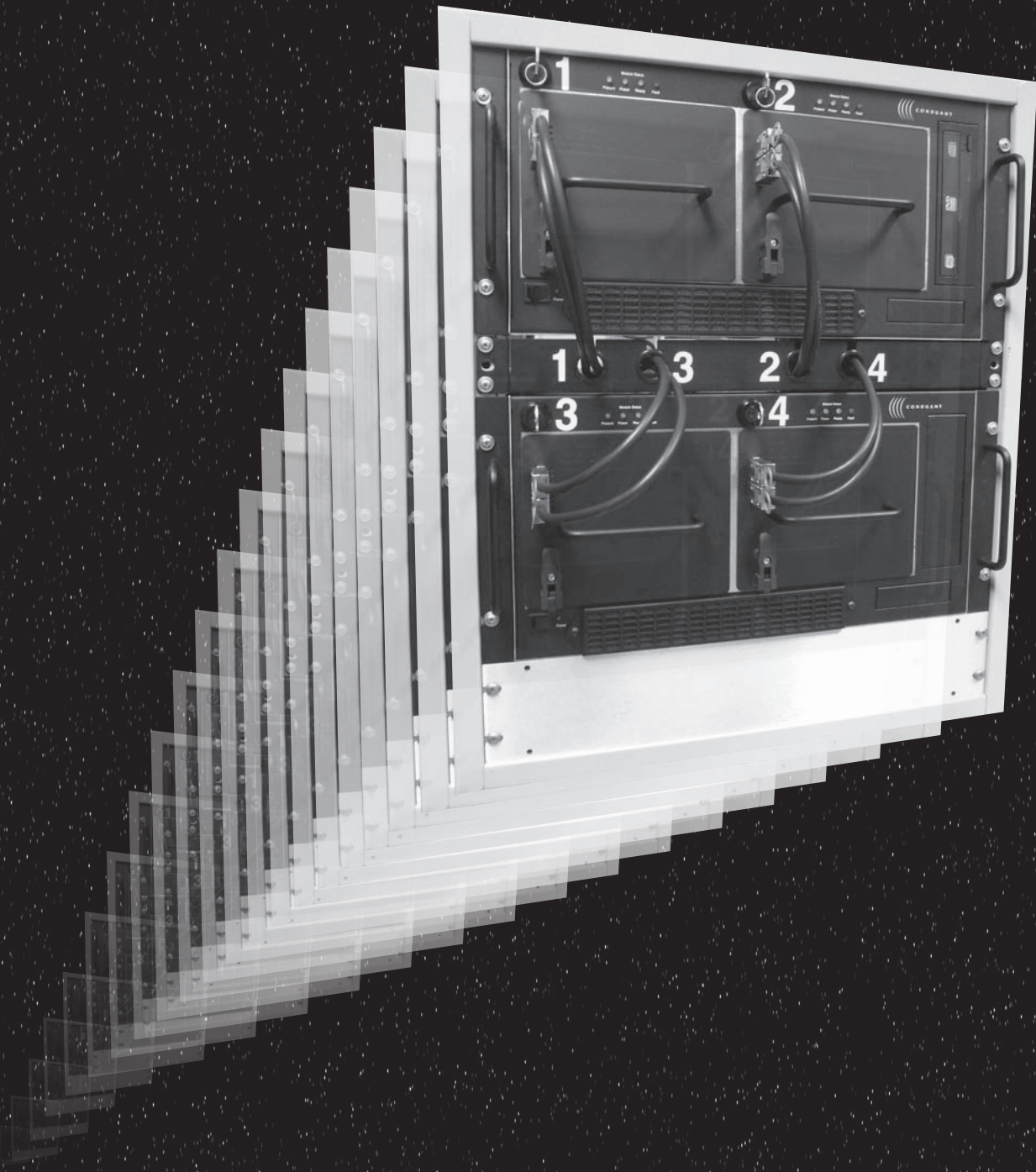

# Operation Centers



# The Bonn Geodetic VLBI Operation Center

*A. Nothnagel, A. Miskens*

## Abstract

The IGGB Operation Center has continued to organize and schedule the IVS-T2, IVS-OHIG, IVS-INT3, and EUROPE sessions.

## 1. Center Activities

The IGGB VLBI Operation Center is located at the Institute of Geodesy und Geoinformation of the University of Bonn, Nussallee 17, D-53115 Bonn, Germany. It has been organizing and scheduling VLBI observing sessions for more than twenty years. The observing series organized and scheduled in 2011 are the same as in 2010.

- **Measurement of Vertical Crustal Motion in Europe by VLBI (EUROPE)**

In Europe, a series of special sessions has been scheduled for the determination of precise station coordinates and for long term stability tests. This year, six sessions with Ny-Ålesund, Onsala, Metsahovi, Svetloe, Zelenchukskaya, Badary, Effelsberg, Wettzell, Simeiz, Madrid (DSS65A), Medicina, Matera, Noto and Yebes (YEBES40M) were scheduled employing the frequency setup of 16 channels and 4 MHz bandwidth in fan-out mode (identical to the setup of the IVS-T2 sessions).

- **IVS-T2 series**

This series has been observed roughly every second month (seven sessions in 2011) primarily for maintenance and stabilization of the VLBI terrestrial reference frame as well as for Earth rotation monitoring as a by-product. Each station of the global geodetic VLBI network is planned to participate at least once per year in the T2 sessions. In view of the limitations in station days, priority was given to stronger and more robust networks with many sites over more observing sessions. Therefore, 12 to 15 stations have been scheduled in each session requiring multiple passes on the IVS correlators. The scheduling of these sessions has to take into account that a sufficient number of observations must be planned for each baseline of these global networks. The recording frequency setup is 16 channels and 4 MHz channel bandwidth.

- **Southern Hemisphere and Antarctica Series (OHIG):**

In February 2011, three sessions of the Southern Hemisphere and Antarctica Series with the Antarctic stations Syowa (Japanese) and O'Higgins (German) plus Fortaleza, Hobart, Kokee, and DSS45 have been organized. Furthermore, OHIGGINS was also included successfully in the T2074 session. The (southern) winter O'Higgins burst was again canceled for various reasons. The purpose of these sessions is the maintenance of the VLBI TRF and monitoring of Earth rotation as a by-product. The recording frequency setup is 16 channels and 4 MHz channel bandwidth. Due to the fact that Syowa is not able to deliver the recorded data for nearly one year after the observations, the correlation and the generation of the databases will be delayed considerably.

- **UT1 determination with near-real-time e-VLBI (INT3):**

The so-called INT3 sessions included the telescopes of Ny-Ålesund, Tsukuba, and Wettzell for weekly UT1 determinations with rapid processing time. Since August 2007 these sessions have been scheduled to start every Monday morning at 7:00 a.m. UT.

The operations of the INT3 series is directly linked to data transmission and correlation since the raw VLBI observation data of the three sites is directly transferred to the Bonn Correlator by Internet connections to speed up delivery of the results. The transmission rate is about 100 Mb/s for Ny-Ålesund (limited due to the use of a radio link for the first part of the distance) and 400 Mb/s from Tsukuba and Wettzell. The correlation is solely carried out with the new DiFX software correlator.

In 2011, 50 sessions were observed and transmitted successfully. 90% of the sessions were correlated and the databases delivered within the first eight hours after the end of the observations. A further 5% were completed within 10 hours. The rest took between 10 and 24 hours due to difficulties with networking hardware.

## 2. Staff

Table 1. Personnel at IGGB Operation Center

Arno Mückens	+49-228-525264	mueskens@mpifr.de
Axel Nothnagel	+49-228-733574	nothnagel@uni-bonn.de



# CORE Operation Center Report

*Cynthia C. Thomas, Daniel MacMillan*

## Abstract

This report gives a synopsis of the activities of the CORE Operation Center from January 2011 to December 2011. The report forecasts activities planned for the year 2012.

## 1. Changes to the CORE Operation Center's Program

The Earth orientation parameter goal of the IVS program is to attain precision at least as good as  $3.5 \mu\text{s}$  for UT1 and  $100 \mu\text{as}$  for pole position.

The IVS program, which started in 2002, used the Mark IV recording mode for each session. The IVS program began using the Mark 5 recording mode in mid-2003. By the end of 2007, all stations were upgraded to Mark 5. Due to the efficient Mark 5 correlator, the program continues to be dependent on station time and media. The following are the network configurations for the sessions for which the CORE Operation Center was responsible in 2011:

IVS-R1: 50 sessions, scheduled weekly and mainly on Mondays, six to eleven station networks

RDV: Six sessions, scheduled evenly throughout the year, 13 to 19 station networks

IVS-R&D: Seven sessions, scheduled monthly, eight to eleven station networks

## 2. IVS Sessions from January 2011 to December 2011

This section displays the purpose of the IVS sessions for which the CORE Operation Center is responsible.

- IVS-R1: In 2011, the IVS-R1s were scheduled weekly with six to eleven station networks. During the year, 21 different stations participated in the IVS-R1 network, but there were only eight stations that participated in at least half of the scheduled sessions—Wettzell (50), Ny-Ålesund (45), Tsukuba (44), Tigo (42), Westford (36), Hobart-12m (27), Kokee (27), and HartRAO (26). Several new stations were added to the IVS-R1s during 2011, Katherine (9), Kashima-11m (9), Warkworth (9), and Yarragadee (8).

The purpose of the IVS-R1 sessions is to provide weekly EOP results on a timely basis. These sessions provide continuity with the previous CORE series. The “R” stands for rapid turnaround because the stations, correlators, and analysts have a commitment to make the time delay from the end of recording to the results as short as possible. The time delay goal is a maximum of 15 days. Participating stations are requested to ship disks to the correlator as rapidly as possible or to transfer the data electronically to the correlator using e-VLBI. The “1” indicates that the sessions are mainly on Mondays.

- RDV: There are six bi-monthly coordinated astrometric/geodetic experiments each year that use the full 10-station VLBA plus up to nine geodetic stations.

These sessions are being coordinated by the geodetic VLBI programs of three agencies: 1. USNO performs repeated imaging and correction for source structure; 2. NASA analyzes

this data to determine a high accuracy terrestrial reference frame; and 3. NRAO uses these sessions to provide a service to users who require high quality positions for a small number of sources. NASA (the CORE Operation Center) prepares the schedules for the RDV sessions.

- R&D: The purpose of the seven R&D sessions in 2011, as decided by the IVS Observing Program Committee, was to test the 512 Mbps recording mode for CONT11 for the first five sessions. The purpose of the last two sessions was to support observations close to the Sun.

### 3. Current Analysis of the CORE Operation Center's IVS Sessions

Table 1 gives the average formal errors for the R1, R4, RDV, and T2 sessions from 2011. The R1 session formal uncertainties are not significantly different from the 2009-2010 errors. The R4 uncertainties for 2011 sessions are better than for 2010. This improvement is likely due to the improved network geometry since several stations were not available in 2010. Specifically, Fortaleza, Katherine, and Yarragadee were not available in 2010. RDV uncertainties are not significantly different among the three years from 2009 to 2011. Clearly the RDV formal errors are significantly better than any of the other experiment series. This is due to the larger number of RDV stations as well as better global geometry.

Table 2 shows the EOP differences with respect to the IGS series for the R1, R4, RDV, and T2 series. The WRMS differences were computed after removing a bias, but estimating rates did not affect the residual WRMS significantly. Both the R1 and R4 series show worse WRMS agreement in x-pole and y-pole for 2011 than for the R1 and R4 series since 2000. This is consistent with the formal error trend for the R4s, but it is not clear why the agreement is worse for the R1s. There are some significant biases greater than 100  $\mu\text{as}$  between the VLBI and GPS series that should be investigated. Formal uncertainties of the bias estimates are not shown, but the polar motion biases are all several sigma. Of all the series, the RDV series has the best WRMS agreement of x-pole and y-pole with IGS in 2011 as well as for all sessions since 2000. However, there are really too few RDV and T2 sessions to give significance to the WRMS differences for 2011 compared with the full series from 2000-2011.

Table 1. Average EOP Formal Uncertainties for 2011.

Session Type	Num	X-pole ( $\mu\text{as}$ )	Y-pole ( $\mu\text{as}$ )	UT1 ( $\mu\text{s}$ )	DPSI ( $\mu\text{as}$ )	DEPS ( $\mu\text{as}$ )
R1	51	65(60,61)	64(58,61)	3.0(3.0,2.4)	112(116,128)	45(47,51)
R4	51	85(96,72)	76(84,77)	3.2(3.2,2.9)	163(172,189)	66(71,72)
RDV	3	42(42,40)	44(43,40)	2.0(2.0,1.7)	71(68,68)	26(28,27)
T2	3	113(93,79)	125(100,89)	5.5(5.2,4.1)	255(192,171)	90(75,69)

Values in parentheses are for 2010 and then 2009.

Table 2. Offset and WRMS Differences (2011) Relative to the IGS Combined Series.

Session Type	Num	X-pole		Y-pole		LOD	
		Offset ( $\mu\text{as}$ )	WRMS ( $\mu\text{as}$ )	Offset ( $\mu\text{as}$ )	WRMS ( $\mu\text{as}$ )	Offset ( $\mu\text{s/d}$ )	WRMS ( $\mu\text{s/d}$ )
R1	51(510)	-102(-43)	108(95)	105(67)	109(87)	0.6(0.2)	17(17)
R4	51(507)	-92(-77)	128(112)	85(62)	129(112)	0.4(1.5)	16(18)
RDV	3(69)	-96(12)	92(78)	127(68)	8(70)	-5.1(-0.3)	9(15)
T2	3(76)	-85(-44)	100(140)	139(47)	253(124)	21.2(1.4)	23(20)

Values in parentheses are for the entire series (since 2000) for each session type

#### 4. The CORE Operations Staff

Table 3 lists the key technical personnel and their responsibilities so that everyone reading this report will know whom to contact about their particular question.

Table 3. Key Technical Staff of the CORE Operations Center.

Name	Responsibility	Agency
Dirk Behrend	Organizer of CORE program	NVI, Inc./GSFC
Brian Corey	Analysis	Haystack
Ricky Figueroa	Receiver maintenance	ITT Exelis
John Gipson	SKED program support and development	NVI, Inc./GSFC
Frank Gomez	Software engineer for the Web site	Raytheon/GSFC
David Gordon	Analysis	NVI, Inc./GSFC
Ed Himwich	Network Coordinator	NVI, Inc./GSFC
Dan MacMillan	Analysis	NVI, Inc./GSFC
Katie Pazamickas	Maser maintenance	ITT Exelis
David Rubincam	Procurement of materials necessary for CORE operations	GSFC/NASA
Braulio Sanchez	Procurement of materials necessary for CORE operations	GSFC/NASA
Dan Smythe	Tape recorder maintenance	Haystack
Cynthia Thomas	Coordination of master observing schedule and preparation of observing schedules	NVI, Inc./GSFC

#### 5. Planned Activities during 2012

The CORE Operation Center will continue to be responsible for the following IVS sessions during 2012.

- The IVS-R1 sessions will be observed weekly and recorded in a Mark 5 mode.

- The IVS-R&D sessions will be observed ten times during the year.
- The RDV sessions will be observed six times during the year.

# NEOS Operation Center

*Kerry Kingham, M.S. Carter*

## Abstract

This report covers the activities of the NEOS Operation Center at USNO for 2011. The Operation Center schedules IVS-R4 and the INT1 Intensive experiments.

## 1. VLBI Operations

NEOS operations in the period covered consisted, each week, of one 24-hour duration IVS-R4 observing session (on Thursday-Friday) for Earth Orientation and five daily one-hour duration “Intensives” for UT1 determination (Monday through Friday). In 2011, the operational IVS-R4 network included VLBI stations at Kokee Park (Hawaii), Wettzell (Germany), Ny-Ålesund (Norway), TIGO (Chile), Svetloe, Badary and Zelenchukskaya (Russia), Hobart (Australia), Yebes (Spain), and Matera and Medicina (Italy). A typical IVS R4 consisted of eight to twelve stations.

The regular stations for the weekday IVS Intensives were Kokee Park and Wettzell. Intensives including Kokee Park, Wettzell, and Svetloe were occasionally scheduled in order to characterize the Kokee Park — Svetloe baseline so that Svetloe can be used as an alternate for Wettzell should it be needed. Odd-day Intensives were scheduled with the scheduling technique used since 2000; even-day Intensives were scheduled with a new, experimental scheduling technique.

The Operation Center updated the version of sked as updates became available.

All sessions are correlated at the Washington Correlator, which is located at USNO and is run by NEOS.

Table 1. Experiments scheduled during 2011.

experiment type	# sessions
IVS-R4	49
Intensives	230

## 2. Staff

K. A. Kingham and M. S. Carter are the only staff members of the NEOS Operation Center. Kingham is responsible for the overall management, and Carter makes the schedules. M. S. Carter is located at the USNO Flagstaff Station (NOFS).



# Correlators

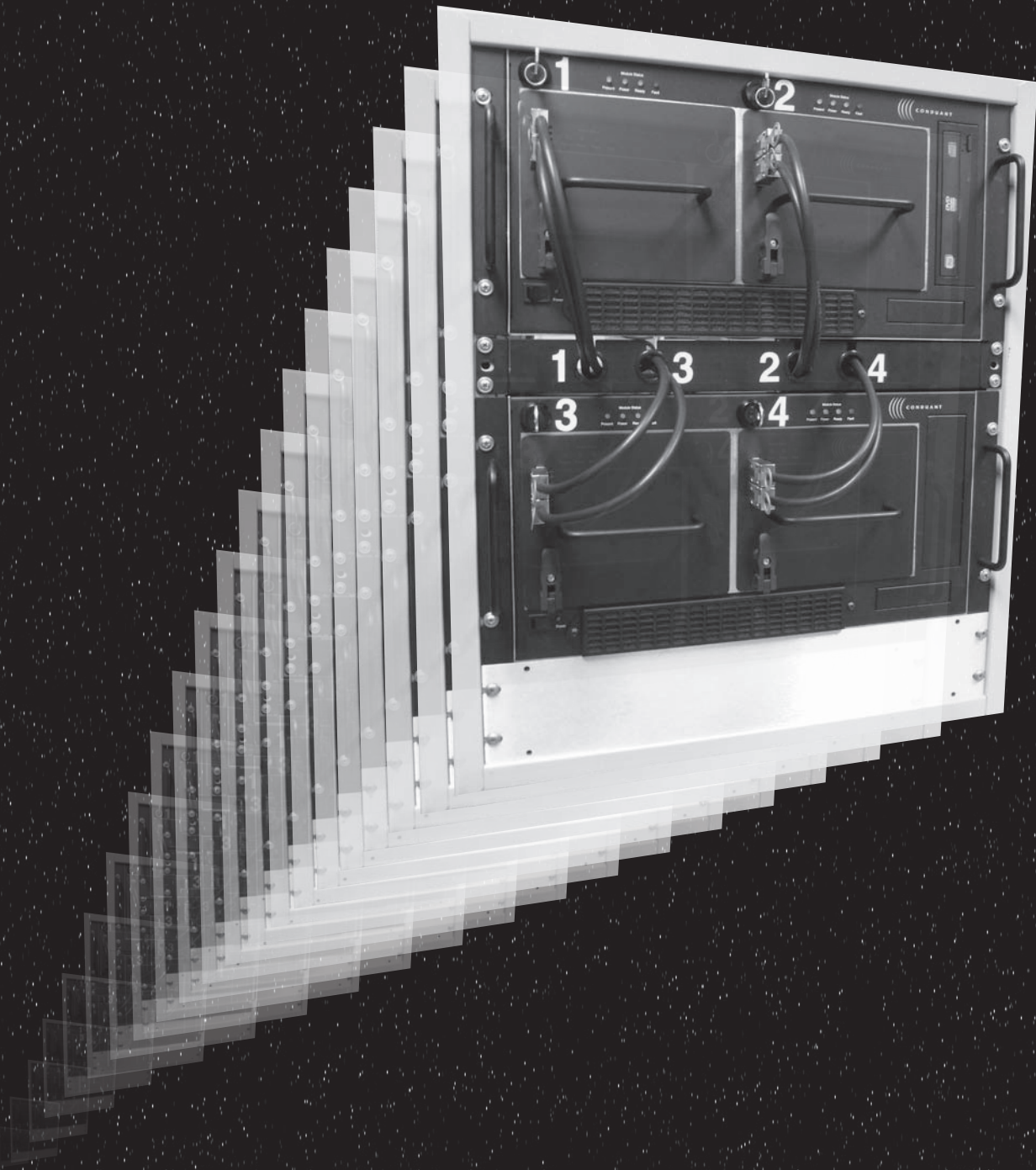

# Correlators





# The Bonn Astro/Geo Correlator

*Laura La Porta, Walter Alef, Simone Bernhart, Alessandra Bertarini, Arno Müskens,  
Helge Rottmann, Alan Roy*

## Abstract

The Bonn Distributed FX (DiFX) correlator is a software correlator operated jointly by the MPIfR and the IGG in Bonn and the BKG in Frankfurt.

## 1. Introduction

The Bonn correlator is hosted at the Max-Planck-Institut für Radioastronomie (MPIfR)<sup>1</sup> in Bonn, Germany. It is operated jointly by the MPIfR and the Bundesamt für Kartographie und Geodäsie (BKG)<sup>2</sup> in cooperation with the Institut für Geodäsie und Geoinformation der Universität Bonn (IGG)<sup>3</sup>. It is a major correlator for geodetic observations and astronomical projects, for instance those involving pulsar gating, millimeter wavelengths, and astrometry.

## 2. Present Correlator Capabilities

The Distributed FX correlator<sup>4</sup> was developed at Swinburne University in Melbourne, Australia by Adam Deller (and collaborators) and adapted to the VLBA operational environment by Walter Brisken and NRAO staff. DiFX in Bonn is installed and running on a High Performance Compute Cluster (HPC cluster – see Figure 1).

Features of the software correlator cluster are:

- 60 nodes (8 compute cores each)
- 4 TFlops in the Linpack benchmark test
- 20 Gbps Infiniband interconnection
- 10 RAIDs (about 380 TBs storage capacity)
- one control node for correlation (*fxmanager*)
- two computers (called *frontend* and *frontend2*) for executing parallelized jobs on the cluster, e.g., post-correlation applications
- one control computer (*appliance*) for installing and monitoring the cluster
- closed loop rack cooling

The correlator cluster is connected via  $2 \times 1$  Gb Ethernet to 14 Mark 5 units<sup>5</sup> used for playing back the data. If more than 14 playback units are required, and in the case of e-VLBI, data are

---

<sup>1</sup><http://www.mpifr.de/div/vlbicor>

<sup>2</sup><http://www.bkg.bund.de/>

<sup>3</sup><http://www.gib.uni-bonn.de/>

<sup>4</sup>DiFX: A Software Correlator for Very Long Baseline Interferometry using Multiprocessor Computing Environments, 2007, PASP, 119, 318

<sup>5</sup><http://www.haystack.mit.edu/tech/vlbi/mark5/>

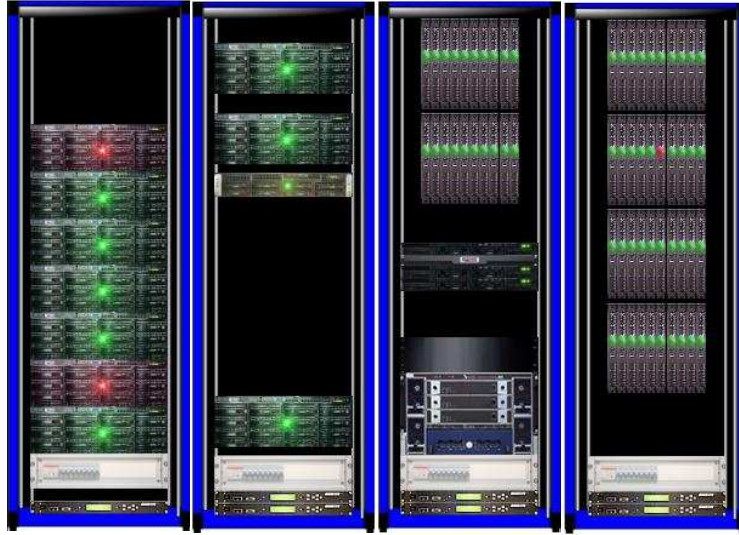

Figure 1. From the left: the first and second racks contain the storage RAIDs and *frontend2*; the third and fourth racks contain the cluster nodes, *fxmanager* and *frontend*.

copied to the raid systems prior to correlation. All Mark 5 can play back all types of Mark 5 data (A/B/C). The disk-modules in the Mark 5 are controlled via NRAO's mk5daemon program. The available functionality includes all necessary functions such as recording the directories of the modules, resetting and rebooting the units, and module conditioning.

A summary of the capabilities of the DiFX software correlator is presented in Table 1.

### 3. Staff

The people in the geodetic group at the Bonn correlator are

**Arno Müskens** - group leader, scheduling of T2, OHIG, EURO, INT3.

**Simone Bernhart** - e-VLBI supervision and operations, experiment setup and evaluation of correlated data, media shipping.

**Alessandra Bertarini** - experiment setup and evaluation of correlated data for both astronomy and geodesy, digital baseband converter (DBBC) testing (APEX fringe test). Friend of the correlator.

**Laura La Porta** - experiment setup and evaluation of correlated data, DBBC testing.

**Frédéric Jaron** - phasecal extraction for software correlator, software support, and Web page maintenance.

**Two student operators** for the night shifts and the weekends.

The people in the astronomical group at the Bonn correlator are

**Walter Alef** - head of the VLBI technical department, computer systems and cluster administration.

**Alan Roy** - deputy group leader, support scientist (water vapor radiometer, technical assistance, development of FPGA firmware for linear to circular polarization conversion, project manager for equipping APEX for millimeter VLBI).

Table 1. Correlator capabilities.

<b>Playback Units</b>	
Number available	14 Mark 5 (4 Mark 5A, 2 Mark 5B, 8 Mark 5C)
Playback speed	1.6 Gbps
Formats	Mark 5A, Mark 5B, LBA, VDIF
Sampling	1 bit, 2 bits
Fan-out (Mark 5A)	1:1, 1:2, 1:4
Nr channels	≤ 16 USB and/or LSB
Bandwidth/channel	(2, 4, 6, 8, 32) MHz
Signal	Single-, dual-frequency; all four Stokes parameters for circular and linear polarization
<b>Correlation</b>	
Geometric model	CALC 9
Phase cal	Phase-cal extraction of all tones in a sub-band simultaneously
Pre-average time	Milliseconds to seconds
Spectral channels	Max no. of FFT tested $2^{18}$
Export	FITS export. Interface to MkIV data format which enables the use of geodetic analysis software and Haystack fringe fitting program.
Pulsar	Pulsar gating possible

**Helge Rottmann** - software engineer for correlator development and operation, cluster administration. DBBC and RDBE control software, Field System.

**Heinz Fuchs** - correlator operator, responsible for the correlator operator schedule, daily operations and media shipping.

**Hermann Sturm** - correlator operator, correlator support software, media shipping, and Web page development.

**Rolf Märten** - technician maintaining cluster hardware and Mark 5 playbacks.

**Gino Tuccari** - guest scientist from INAF, DBBC development, DBBC project leader.

**Michael Wunderlich** - engineer, development and testing of DBBC components.

**Jan Wagner** - PhD student, support scientist for APEX, DBBC development, DiFX developer.

**David Graham** - consultant (technical development, DBBC development and testing).

#### 4. Status

**Experiments:** In 2011 the Bonn group correlated sixty-five R1, six EURO, seven T2, six OHIG, forty INT3, and about twenty astronomical experiments.

**e-VLBI:** e-transfers to Bonn are performed on a regular basis from Tsukuba, Ny-Ålesund, Onsala, Fortaleza, Hartebeesthoek, Metsähovi, Wettzell, Kashima (including data of the antarctic Syowa station), Aira, Chichijima, Japanese VERA stations Ishigakijima (all from Tsukuba) and Mizusawa (from Mitaka), Medicina, Yebes, Hobart and Warkworth. E-transfer reduces the time between observation and correlation since no shipment is required. The achieved data rates range from 100 Mb/s with Ny-Ålesund (limited by radio link) to 600 Mb/s with peaks up to 800 Mb/s

(with Metsähovi). The transfers are done using the UDP-based Tsunami protocol. The total disk space available for e-VLBI data storage at the correlator is currently about 70 TB. A webpage has been developed (<http://www.mpifr-bonn.mpg.de/cgi-bin/showtransfers.cgi>), which shows currently active (Tsunami) e-transfers and helps to coordinate transfer times and rates on a first come-first served base.

**DiFX software correlator:** A graphical user interface was installed on the DiFX control computer, which simplifies the use of the software correlator.

A new graphical user interface (comedia) has been implemented to replace the old tape library administration software. Comedia permits the operator to monitor the modules from the time they arrive at the correlator to the moment they are sent back to the stations. In particular, it allows one to trace whether a module can be released, a feature that was not present in the old tape library. All experiment and module related metadata are stored in a relational database.

The DiFX software correlator has been operated at Bonn since 2009 and has been continuously updated and improved. Thanks to the possibility of performing pulsar gating, the DiFX correlator in Bonn became a top center for the correlation of EVN pulsar experiments. Significant improvements have been made to adapt the DiFX correlator to the geodetic export path via Mark IV format and fourfit, although some issues are left that will probably soon be resolved. This requires at present some work-arounds sometimes causing delays in the submission of experiment databases.

A branch version of the DiFX software correlator for RFI mitigation is being developed as part of a PhD project.

**DBBC:** The Bonn group is involved in the development of the DBBC for the European VLBI Network (EVN) and geodesy. The DBBC is designed as a full replacement for the existing analog BBCs. The following stations have already bought one or more DBBCs: APEX, AuScope (Australia), Effelsberg, Onsala, Pico Veleta, Yebes, Wettzell, and Warkworth. The functionality of these DBBCs is currently being tested. The AuScope and Effelsberg stations already use the DBBC in their regular observations. A test at 2 Gbps was successfully performed using the Effelsberg and Onsala DBBCs in July 2011.

**APEX:** The Bonn VLBI group is equipping the APEX telescope for VLBI observations at 1 mm. The first fringe tests were performed in March 2011 (results pending).

## 5. Outlook for 2012

**DiFX Correlator:** Continue testing the DiFX software and ancilliary programs to match the geodetic needs.

**e-VLBI:** Tests of e-VLBI transfer with other antennas are planned or ongoing. In order to meet the requirements of the higher observing rate foreseen within VLBI2010, it is planned to upgrade the Internet connection from 1 Gbps to 2 Gbps. However, there are some issues concerning funding and technical implementation.

**DBBC:** Continue DBBC testing in the EVN stations that recently acquired DBBCs. Wide bandwidth modes are also under test. First observations at 2 Gbps are planned for 2012.

**APEX** Further fringe tests will take place at APEX in March 2012.

**Phasing up ALMA** The group is involved in an international project to add array phasing capability to ALMA. This will enable its use as an extremely sensitive station in 1 mm VLBI experiments.

# Haystack Observatory VLBI Correlator

*Mike Titus, Roger Cappallo, Brian Corey, Kevin Dudevoir, Arthur Niell, Alan Whitney*

## Abstract

This report summarizes the activities of the Haystack Correlator during 2011. Highlights include acquisition of new hardware for a DiFX cluster, development and improvement of tools to facilitate DiFX production, more u-VLBI Galactic Center observations, Mark 6 recording system testing, and various other continuing projects. Non-real-time e-VLBI transfers and engineering support of other correlators continued.

## 1. Introduction

The Mark IV and DiFX VLBI correlators of the MIT Haystack Observatory, located in Westford, Massachusetts, are supported by the NASA Space Geodesy Program and the National Science Foundation. They are dedicated mainly to the pursuits of the IVS, with a smaller fraction of time allocated to processing radio astronomy observations for the Ultra High Sensitivity VLBI (u-VLBI) project. The Haystack correlators serve as a development system for testing new correlation modes, for hardware improvements such as the Mark 6 system, and in the case of the Mark IV, for diagnosing correlator problems encountered at Haystack and at the identical correlator at the U.S. Naval Observatory. This flexibility is made possible by the presence on-site of the team that designed the Mark IV correlator hardware and software. Some software support is provided to the Max Planck Institute for Radioastronomy (MPI) in Bonn, Germany for DiFX processing of IVS experiments.

## 2. Summary of Activities

### 2.1. DiFX Cluster Acquisition

Commissioning of the DiFX correlator has accelerated. Acquisition of cluster hardware began in mid-2011. This included the purchase of six Supermicro server machines with 12-core Intel CPUs, an infiniband switch, and infiniband cards for each server and some of the capable Mark 5 units. Configuration and testing of the cluster and new hardware are in progress. The transition to all-DiFX correlation is expected in the first half of 2012 but will be coupled with hardware correlator comparison tests. Some comparison tests of many experiment types have already been done with the existing setup. The annual DiFX developers' meeting, which was held at Haystack in 2011, resulted in much progress adapting some of the other sites' tools, such as the database system developed at MPI and a GUI developed at USNO. Other tools will be adapted by mid-2012.

### 2.2. DiFX Software Support

Meanwhile, the development of the tools to support conversion of DiFX output to Mark IV format has continued, such as the difx2mark4 utility for converting DiFX correlator output and an export package of HOPS tools to facilitate post-processing data analysis at other institutions. Some of these tools have been installed at Goddard and used to process geodetic experiments.

### 2.3. Broadband Delay

Although Broadband Delay “production” observing has been light this year, one major milestone was reached in seeing first fringes to the Patriot 12-meter antenna which was recently completed at the GGAO site. Two fringe tests were conducted over the last year, one in March and another in June.

### 2.4. Galactic Center Observations

Further u-VLBI observations of the Galactic Center were conducted and correlated. The lessons from 2010’s engineering test of a phased-array processor system to combine the collecting area of interferometer elements on Mauna Kea were applied to the interferometer elements at the CARMA site.

### 2.5. WACO Support

Similar to 2009, the Haystack correlator was used during the Technical Operations Workshop (TOW) held at Haystack in May to process Kokee-Wettzell Intensive sessions, with the data then being sent down to WACO for cleanup and export. This demonstrated that Haystack can serve as a backup correlation site in the event of down time at WACO. Another experiment, an APSG, was correlated at Haystack to reduce WACO’s processing backlog. The raw correlator output was fourfited and exported by WACO. This correlation was also done to fulfill contractual requirements to USNO.

### 2.6. Bonn Support

A significant amount of support for difx2mark4 and HOPS issues was provided to the Bonn DiFX correlator to facilitate geodetic operations. Also, the Haystack Correlator gave support related to the SgrA\* Galactic Center observations conducted in April to facilitate fringe searches for two newly participating MPI-sponsored antennas.

### 2.7. Special IYA Export

A special export of the IYA-2009 data was made for Arnaud Collioud of Bordeaux Observatory to allow imaging of sources in the AIPS software package (one of the goals of the IYA session). Assistance was also provided for the HOPS software package so that the data could be prepped for reading into AIPS through the MPI-developed mk4in method.

### 2.8. RDV Fourfitting

With NRAO converted to DiFX correlation, the option of processing RDV experiments through the HOPS/Mark IV data path, as opposed to the AIPS path, has opened. In order to test the viability of this path, RDV85 through RDV89 were converted to the Mark IV data structure with difx2mark4 and then fourfited. It was concluded that the Mark IV data path is preferable, so we are developing a procedure to turn Mark IV conversion and fringing into the default method.

## 2.9. Mark 6 Testing

A live demonstration of 16 Gb/sec recording with RDBEs and Mark 6 data recorders was performed at the TOW meeting in May. Another test was conducted in October between GGAO and Westford, where fringes were obtained using RDBE digital back ends and Mark 6 data recorders. A description of the Mark 6 system and those demonstrations can be found at:

*[http://www.haystack.mit.edu/tech/vlbi/mark6/mark6\\_memo/04-2011.12.05-Mark6\\_data\\_system-DiFX\\_mtg-Haystack.pdf](http://www.haystack.mit.edu/tech/vlbi/mark6/mark6_memo/04-2011.12.05-Mark6_data_system-DiFX_mtg-Haystack.pdf)*

## 2.10. e-VLBI

Non-real-time transfers have continued. Data from thirty-two experiments were transferred to Haystack this year from nine stations (eight in Japan, and one in Sweden): Kashima34, Kashima11, Koganei, Tsukuba, Chichijima, Ishigaki, Aira, Mizusawa, and Onsala. e-VLBI transfers will significantly increase this coming year due to an upgrade of Haystack's connectivity to the Internet, which enables higher data transfer rates.

## 2.11. Experiments Correlated

Production processing using the Mark IV correlator continues amidst all the DiFX development. In 2011, twenty-nine geodetic VLBI experiments were processed, at least in part, on the Haystack Mark IV correlator, consisting of six R&Ds, six T2s, an AUST experiment, an APSG, and the Intensives during the TOW for USNO as mentioned before. The remainder were various tests. The R&Ds were especially important this year as they were preparatory tests for the CONT campaign which ran in September. This pre-testing was designed to ensure that the CONT campaign collected the highest quality data possible. The other test experiments included the broadband fringe tests and an assortment of other projects, some of which were touched on in the summary above. As usual, there were smaller tests that are not included in the above count because they were too small to warrant individual experiment numbers.

## 3. Current/Future Hardware and Capabilities

As of the end of 2011, the Mark IV correlator was comprised of seven Mark 5A units, seven station units, seven Mark 5B units (DOMs) with their associated correlator interface boards (CIBs), 16 operational correlator boards, two crates, and miscellaneous other support hardware. We have the capacity to process all baselines for 11 stations simultaneously in the standard geodetic modes, provided the aggregate recordings match the above hardware matrix. Note that all experiments up to 15 stations have been done in one pass due to the ability to share playback units between stations which do not co-observe. A subset of the playback units is accessible to the DiFX cluster.

In 2012 we hope to transition to the software correlator, only keeping the hardware correlator alive in support of USNO until their transition to a software correlator, which is expected in late 2012.

## 4. Staff

Staff who participated in aspects of Mark IV, DiFX, Mark 5/6, and e-VLBI development and operations include:

### 4.1. Software Development Team

- John Ball - Mark 5A/5B; e-VLBI
- Roger Cappallo - real-time correlator software and troubleshooting; system integration; post-processing; Mark 5B/5C/6; Linux conversion; e-VLBI; DiFX correlator development
- Geoff Crew - DiFX correlator development, post-processing software; Mark 6
- Kevin Dudevoir - correlation; maintenance/support; Mark 5A/5B/5C; e-VLBI; Linux conversion; correlator software and build system development; computer system support/development; DiFX correlator development
- Jason SooHoo - e-VLBI; Mark 5A/5B/5C/6; computer system support
- Chester Ruszczyk - e-VLBI; Mark 5A/5B/5C
- Alan Whitney - system architecture; Mark 5A/5B/5C/6; e-VLBI

### 4.2. Operations Team:

- Peter Bolis - correlator maintenance
- Brian Corey - experiment correlation oversight; station evaluation; technique development
- Dave Fields - playback drive maintenance; Mark 5 installation and maintenance; general technical support
- Glenn Millson - correlator operator
- Arthur Niell - technique development
- Don Sousa - correlator operator; experiment setup; tape library and shipping
- Mike Titus - correlator operations oversight; experiment setup; computer services; software and hardware testing
- Ken Wilson - correlator maintenance; playback drive maintenance; general technical support

## 5. Conclusion/Outlook

A full transition to the DiFX software correlator is expected by mid-2012. Testing of a complete VLBI2010 system comprised of new front and back end hardware at a station is expected to start in early 2012. Testing and implementation of new digital back ends and recording systems will continue.



## IAA Correlator Center

*Igor Surkis, Voitsekh Ken, Alexey Melnikov, Vladimir Mishin, Nadezda Sokolova,  
Violet Shantyr, Vladimir Zimovsky*

### Abstract

The activities of the six-station IAA RAS correlator include regular processing of national geodetic VLBI programs Ru-E, Ru-U, and Ru-F. The Ru-U sessions transferred in e-VLBI mode and correlated in the IAA Correlator Center automatically since 2011.

### 1. Introduction

The IAA Correlator Center is located at and staffed by the Institute of Applied Astronomy in St.-Petersburg, Russia.

The IAA Correlator Center is devoted to processing geodetic, astrometric, and astrophysical observations made with the Russian national VLBI network Quasar.



Figure 1. View of the six-station ARC correlator, showing four racks containing (left to right) signal distribution and synchronization system (SDSS) and three Mark 5B playback units, two correlator crates and KVM, three correlator crates, and one more cabinet with SDSS and three Mark 5B playback units.

## 2. Component Description

The ARC (Astrometric Radiointerferometric Correlator) (Figure 1) was the main data processing device in the IAA Correlator Center in 2011. The ARC was designed and built in the IAA RAS in 2007 - 2009. The correlator has XF design and is based on FPGA technology.

The ARC is a six-station, 15-baseline correlator. It is able to process up to 16 frequency channels on each baseline, for a total of 240 channels. The correlator accesses two-bit VLBI signals with 32 MHz maximal clock frequency. The maximal data range from each station is 1 Gbit per second. The correlator requires VSI-H input VLBI signals, and it is equipped with Mark 5B playback terminals.

In 2011 the correlator control software was improved to obtain almost fully automatic data transfer and processing in e-VLBI mode. Special software corrections were made due to the use of R1002M DAS at Quasar stations.

The ARC was used for processing all of the national geodetic VLBI observations in the IAA Correlator Center in 2011.

In 2011 the DiFX software correlator was installed in the IAA on a Sun Fire X4450 Server. The DiFX works as a virtual machine under the VMware, and it is used in some astrophysical experiments.

## 3. Staff

- Voitsekh Ken — hardware developer;
- Alexey Melnikov — software developer, scheduler of the Ru-sessions;
- Vladimir Mishin — software developer, data processing;
- Nadezda Sokolova — software developer;
- Violet Shantyr — software developer, post processing;
- Igor Surkis — leading investigator, software developer;
- Vladimir Zimovsky — hardware developer, data processing;
- Ekaterina Medvedeva — data processing.

# VLBI Correlators in Kashima

*Mamoru Sekido, Ryuichi Ichikawa*

## Abstract

K5 VLBI data acquisition and processing systems developed at the Kashima Space Technology Center have been used for R&D VLBI experiments. Correlation tasks processed in 2011 were mainly for crustal deformation monitoring between the Kashima 11-m and Koganei 11-m stations after the big earthquake that occurred on 11 March 2011.

## 1. General Information

The VLBI group of the Kashima Space Technology Center (KSTC) of the National Institute of Information and Communications Technology (NICT: Figure 1) has been contributing to the VLBI community by developing the K5 VLBI data acquisition system (DAS) and correlation systems.

The multi-channel DAS named K5/VSSP32 [1] has been used for geodetic and radio science observations. A corresponding software correlation package for the K5/VSSP32 DAS has been developed and maintained by Dr. T. Kondo. Another high speed software correlator called “GICO3” [2], has been developed by M. Kimura.

The K5/VSSP32 system is a multi-channel data acquisition system with four channels input per unit. One unit has the sampling capability in the range of 40 kHz to 64 MHz at 1, 2, 4, and 8 bits quantization within the limit of output data rate up to 256 Mbps. A geodetic K5 DAS system is composed of four K5/VSSP32 units. The K5/VSSP software package contains a variety of VLBI data manipulation utilities from data acquisition with the K5/VSSP32 in accordance with the observation schedule file and data checking of K5 and Mark 5 data, to conversion between K5/VSSP32 format and the Mark IV, Mark 5, and VLBA data formats. This DAS and the software correlator package have been widely used for geodesy operationally. e-VLBI experiments for rapid UT1 measurements have been performed by using the K5 software correlator for the Onsala, Metsähovi, Tsukuba, and Kashima stations [3, 4].

Another K5 system (K5/VSI) is the name of the recording system with a VSI-H interface. NICT has developed three kinds of samplers with a VSI-H interface [5] (see Table 1). Thus a variety of combinations of sampling rate and number of output channels is possible. And the K5/VSI can be connected with not only NICT’s ADS samplers, but also any sampler with a VSI-H compliant data interface. A good example is the combination use of the K5/VSI and Mark 5B

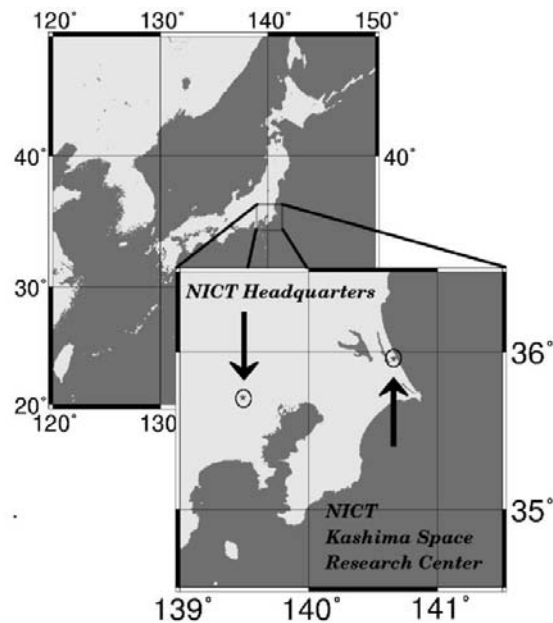

Figure 1. Locations of NICT Headquarters and KSTC.

Table 1. Three VLBI samplers with VSI-H interface developed by NICT

	<b>ADS1000</b>	<b>ADS2000</b>	<b>ADS3000Plus</b>
<b>Pictures</b>			
<b>Sampling rate</b>	1024Msps	64Msps	~ 4Gsps
<b>No. of inputs</b>	1	16	4
<b>No. of channels</b>	1	16	Programmable
<b>Max. Data Rate</b>	2048Mbps	2048Mbps	8192Mbps

sampler at Wettzell, which has routinely been used for real-time data transfer in the INT2 sessions. The VSI-H output data stream from the Mark 5B sampler is captured by the K5/VSI. Then it is transferred to the Tsukuba station and recorded in K5/VSSP32 format in real-time for ultra-rapid UT1 measurements on the Wettzell—Tsukuba baseline.

## 2. Staff

The mega-earthquake that occurred on 11 March 2011 caused destruction of roads and some parts of KSTC's buildings. Fortunately there were no personal injuries in our laboratory.

The names of the staff members who contribute to the Correlation Center at NICT/Kashima and their tasks are listed below in alphabetical order.

- HASEGAWA Shingo: in charge of maintenance and troubleshooting of K5 system computers, operation of the 34-m antenna for IVS sessions.
- HOBIGER Thomas: working at Koganei Headquarters in Tokyo for development of a new VLBI database system that uses NetCDF, research on atmospheric delay calibration with the ray tracing technique, and development of a software receiver for GNSS.
- ICHIKAWA Ryuichi: VLBI Project Manager at Kashima, in charge of research on the small size antenna with wide band receiver system named MARBLE project [6] and on atmospheric delay with ray tracing.
- KAWAI Eiji: in charge of maintenance of the 34-m and 11-m telescopes, operation of the telescopes for IVS sessions.
- KIMURA Moritaka: developer of the high speed Gigabit software correlator “GICO3” and the K5/VSI DAS. He left from KSTC at the end of March 2011.
- KONDO Tetsuro: continuing development and maintenance of the software correlator package of the K5/VSSP32.
- SEKIDO Mamoru: e-VLBI development, Time and Frequency transfer experiments, and maintenance of the 34-m and 11-m antennas.
- TAKEFUJI Kazuhiro: correlation processing operation with GICO software correlator, development of MARBLE antenna, and its application for Time and Frequency transfer.
- TSUTSUMI Masanori: maintenance of K5 system computers and network environment.

### 3. Component Description

After the big earthquake occurred on 11 March 2011 in the north east region of Japan, post-seismic crustal deformation monitoring with the Kashima-Koganei VLBI baseline was regularly conducted from 7 May 2011 until October with a 20 day interval (Figure 2). Correlation processing of these data were performed by using Multi-core PC (e.g., CPU Intel Core i7 920 2.67 GHz cache 8192KB, Processor 4 (Hyper Threading Total Core8), Memory 12 GB) and cluster of PCs, which are used for data recording of K5/VSSP32. Table 2 shows a list of experiments processed at Kashima.

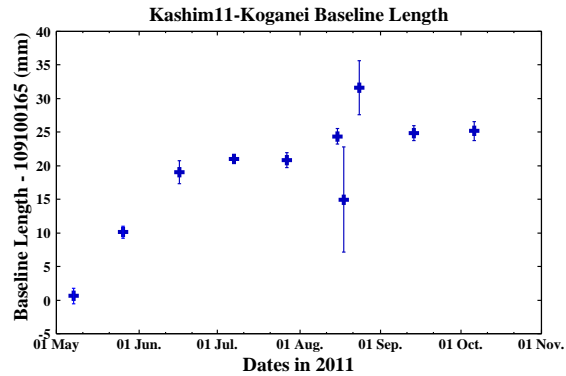

Figure 2. Post-seismic baseline length changes of Kashima11 – Koganei11 from sessions that were correlated at NICT and are listed in Table 2, as well as APSG29 and T2077 (which were correlated at GSI/Tsukuba and are omitted from Table 2). The APSG29 and T2077 points have the largest error bars.

Table 2. Major correlation tasks processed at Kashima in 2011. The first eight sessions (K11127 through K111279) are also shown in Figure 2. R&D experiment D11292 is not shown in that figure.

Project	Exp code	Date	Stations	baseline x scans	Data rate (Mbps)
Geodesy	K11127	7 May	K1, Kg	1 x 1085	256
Geodesy	K11146	26 May	K1, Kg	1 x 1379	256
Geodesy	K11167	16 Jun.	K1, Kg	1 x 1338	512
Geodesy	K11188	07 Jul.	K1, Kg	1 x 1192	512
Geodesy	K11208	27 Jul.	K1, Kg	1 x 1256	512
Geodesy	K11227	15 Aug.	K1, Kg	1 x 1264	512
Geodesy	K11256	13 Sep.	K1, Kg	1 x 1278	512
Geodesy	K11279	6 Oct.	K1, Kg	1 x 1278	512
Direct Sampling	D11292	19 Oct.	K1, Ts	1 x 928	1024

Ts:Tsukuba-32m, K1:Kashima-11m, Kg:Koganei-11m

## 4. Development and Future Plans

### 4.1. Direct Sampling Experiment

A geodetic VLBI experiment with the Radio Frequency Direct Sampling system was conducted on 19 October, and its data were processed with the GICO3 software correlator. That system samples joined S-band and X-band radio frequency signals simultaneously with 1024 MHz-2bit quantization. It uses an aliasing effect to record the signal outside of the Nyquist frequency range of the sampling rate. A total of 1.5 GHz of frequency range of X-band was recorded with 1024 MHz sampling. Reversely folded frequency signals of X-band and S-band were processed separately

with different RF correlation parameters in accordance with the observation. Since only a single sampler is used for dual band observation, a sampling clock offset between S and X-band could be avoided. Thus it has the potential to be a key technology for utilizing phase delay observables across the wide frequency band. More details are described in “Technology Development Center at NICT” in this volume [7].

## References

- [1] T. Kondo, et al.: Development of a New VLBI Sampler Unit (K5/VSSP32) Equipped with a USB 2.0 Interface, IVS 2006 General Meeting Proceedings, edited by Dirk Behrend and Karen Baver, NASA/CP-2006-214140, pp.195-199, 2006.
- [2] M. Kimura, et al.: High Speed VLBI Software Correlator, Submitted to Pub. Astr. Soc. Pacific, 2010.
- [3] Sekido. M., H. Takiguchi, Y. Koyama, T. Kondo, R. Haas, J. Wagner, J. Ritakari, S. Kurihara, K. Kokado: Ultra-rapid UT1 measurement by e-VLBI, *Earth Planets and Space*, **60**, pp.865-870, 2008.
- [4] Matsuzaka S., S. Kurihara, M. Sekido, T. Hobiger, R. Haas, J. Ritakari, J. Wagner: Ultra-rapid dUT1 Measurements on Japan-Fennoscandian Baselines - Application to 24-hour Sessions, IVS 2010 General Meeting Proceedings, pp.143-147, 2010.
- [5] Whitney, A. R.: VLBI Standard Hardware Interface Specification -VSI-H Rev. 1.0<sup>1</sup>, 2000.
- [6] Ichikawa, R., et al.: Present Status and Outlook of Compact VLBI System Development for Providing over 10km Baseline Calibration, IVS NICT-TDC News <sup>2</sup>, **30**, pp. 22-25, 2009.
- [7] K. Takefuji et al.,: Technology Development Center at NICT, International VLBI Service for Geodesy and Astrometry 2011 Annual Report, edited by D. Behrend and K. D. Baver, this volume, 2012.

---

<sup>1</sup><http://www.vlbi.org/vsi/>

<sup>2</sup><http://www2.nict.go.jp/aeri/sts/stmg/ivstdc/news-index.html>

# Tsukuba VLBI Correlator

*Kensuke Kokado, Shinobu Kurihara, Ryoji Kawabata, Kentaro Nozawa*

## Abstract

This report briefly summarizes activities at the Tsukuba VLBI Correlator in 2011. The Tsukuba VLBI Correlator processed 145 IVS Intensive sessions and eight Japanese domestic sessions via the K5/VSSP correlation system, which includes some K5/VSSP kernel software. We improved a software correlation system and succeeded in shortening the latency of VLBI sessions. All of the sessions performed after the improvement were correlated by the software correlation system.



Figure 1. Tsukuba VLBI Correlator.

## 1. Introduction

The Tsukuba VLBI Correlator is a part of VLBI facilities operated by the Geospatial Information Authority of Japan (GSI) as well as the Tsukuba 32-m VLBI station (TSUKUB32). A principal component of our correlation system is the K5/VSSP correlation software package developed by the National Institute of Information and Communications Technology (NICT). We can install the software on commercially-based computers operated by CentOS (Linux OS). We have processed IVS-INT2 sessions and domestic VLBI sessions (JADE sessions) with a number of computers on which the K5/VSSP software package was installed. The sessions we processed in 2011 are described in Section 4. The number of processed sessions was dramatically increased because additional INT2 sessions on the baseline between the Kokee and Wettzell stations were implemented after the 2011 earthquake off the Pacific coast of Tohoku.

## 2. Component Description

The system components of the Tsukuba VLBI correlator are described in Table 1. We have two systems to process the observed data from international sessions or domestic sessions.

System 1 is an old correlation system which was used for correlation of JADE sessions and JAXA sessions. It is operated by a management application “PARNASSUS” (Processing Application in Reference to NICT’s Advanced Set of Software Usable for Synchronization) designed for distributed correlation processing.

System 2 is a new correlation system which is mainly used for correlation of INT2 sessions. We introduced distributed processing programs written in Perl script into the system. The programs have been developed by GSI since 2009 and routinely used since 2010. The framework of the programs is shown in Figure 2. We can correlate the VLBI data automatically with the new distributed processing programs. MK3TOOLS is a program to create Mark III databases from the output files of bandwidth synthesis program for K5/VSSP.

All of the hardware consists of commercially-based products operated on CentOS version 5.4 or 5.5. Now all of the servers work well.

For the INT2 sessions, we have transferred the data from the Wettzell or the Kokee station to the Tsukuba correlator via high-speed network. The Tsukuba Correlator has been connected to high-speed network “SINET4 (Science Information NETwork4)” operated by the National Institute of Informatics (NII). The effective network bandwidth was increased from 1 Gbps to 10 Gbps in October 2011. The network enables us to perform a real-time data transfer from the Wettzell or the Onsala station to the Tsukuba correlator.

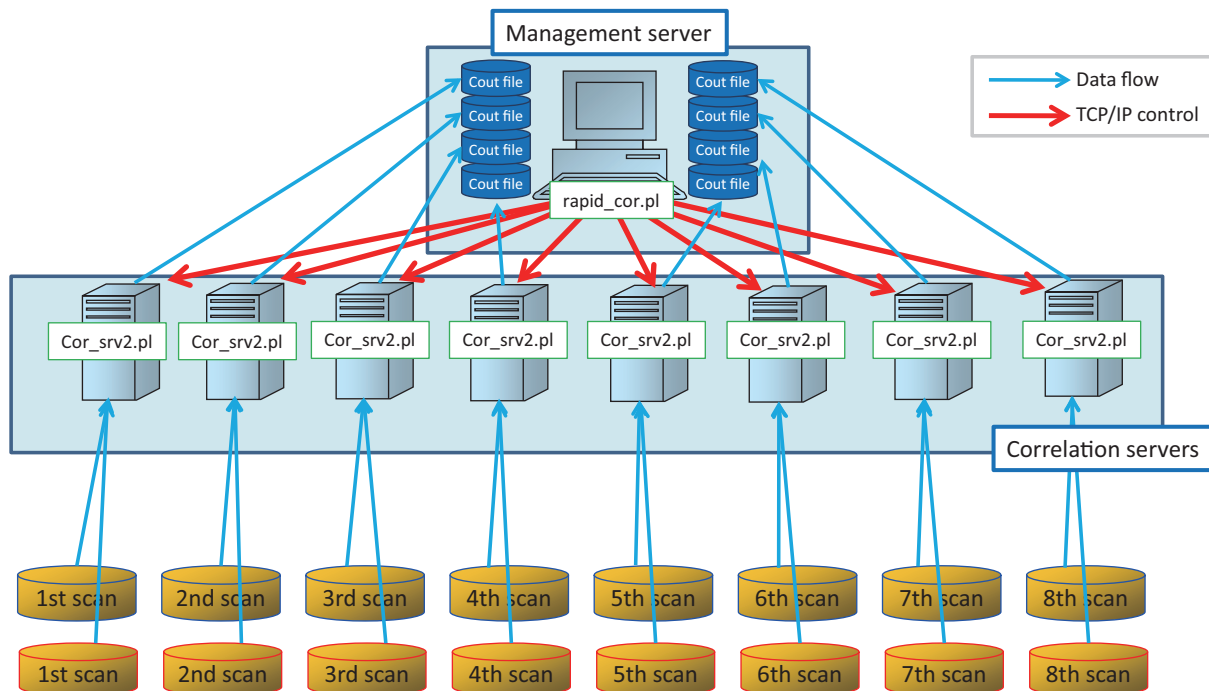

Figure 2. The framework of new distributed processing programs.



Table 1. Specifications of the K5/VSSP correlation system components.

	System 1	System 2
Management Server (CPU)	1 server (Intel Pentium 4, 3.0 GHz)	2 servers (Intel Xeon 3.4 GHz dual CPU)
Correlation Servers (CPU)	16 servers (Intel Xeon 3.06 GHz dual CPU)	8 servers (Intel Xeon 3.4 GHz dual CPU)
Data Servers (CPU)	24 servers (Intel Pentium 4, 3.0 GHz)	8 servers (Intel Xeon 3.07 GHz quad CPU)
File system	NFS	Luster File System
Main application	PARNASSUS 1.3	Perl Programs
Operating System	CentOS version 5.4, version 5.5	
Processing Sessions	JADE sessions Additional domestic sessions ( until July, 2011 )	IVS-INT2 sessions JADE sessions JAXA sessions

### 3. Staff

The technical and engineering staff of the Tsukuba VLBI Correlator is as follows. Most of our staff members are subcontract engineers from private companies, the Advanced Engineering Service Co., Ltd (AES) and the Institute of Japanese Union of Scientists and Engineers (I-JUSE).

- Kensuke Kokado (GSI): Correlation Chief, Management of overall activity
- Kentaro Nozawa (AES): Main operator of the correlation work
- Takashi Nishikawa (AES): Sub-operator of the correlation work
- Toshio Nakajima (I-JUSE): System Engineer for computers and network

### 4. Current Status and Activities

#### 4.1. Processing of JADE Sessions

JADE sessions are domestic 24-hour VLBI sessions scheduled by GSI. The participating stations in the session are four GSI stations (TSUKUB32, SINTOTU3, CHICHI10, and AIRA) and two VERA stations (VERAMZSW and VERAISGK) of the National Astronomical Observatory of Japan (NAOJ). The TSUKUB32 and VERAISGK stations are connected to broad-band network, so we can transfer the data via network. However, the other stations' network transfer rates are too slow to transfer the data to the correlator. Therefore, we have to send the data by shipment of hard disk. We have more than 100 hard disks for shipment, because we need more than four disks per station for each JADE session.

The JADE and JAXA sessions processed at the Tsukuba correlator in 2011 are described in Table 2. The JAXA series was registered by IVS in March 2011, and we submitted all of the databases that had been observed since 2006. The processing factor of each session is described in the rightmost column of Table 2. Although the processing times depend on the number or the performance of the correlation servers, we succeeded in shortening the processing times by installing the "Lustre File System" and the new distributed processing programs. As a result, the processing factor per baseline of sessions after September 2011 is smaller than that of the sessions before that.

Table 2. JADE sessions processed in 2011.

Session	Stations	Processed Baseline #	Processing Factor
JADE-1101	TsAiCcVmVs	10	4.00
JAXA-1101	TsAiCcUd	6	1.61
JADE-1104	TsAiCcS3	4	1.68
JADE-1105	TsS3	1	0.59
JADE-1106	TsAiCcS3Vm	4	0.77
JADE-1109	TsK1KgCcS3VmVs	16	3.38
JADE-1110	TsS3	1	0.42
JADE-1111	TsS3	1	0.07
JADE-1112	TsS3	1	0.06
Ts:TSUKUB32, Ai:AIRA, S3:SINTOTU3, Cc:CHICHI10, Vm:VERAMZSW Vs:VERAISGK, Ud:USUDA, K1:KASHIM11, Kg:KOGANEI			

## 4.2. Processing of IVS-INT2 Sessions

The Tsukuba correlator also processes the data of IVS-INT2/INT3 sessions. Usually, the INT2 sessions are observed on the Tsukuba-Wetzell baseline twice a week (Saturday and Sunday). However, a number of additional INT2 sessions on the Kokee-Wetzell baseline were implemented after the 2011 earthquake off the Pacific coast of Tohoku, so the number of INT2 sessions processed by the Tsukuba correlator was dramatically increased. The number of the processed sessions is shown in Table 3.

We have transferred all of the data via high-speed network. Especially, the data observed at Wetzell station is transferred and converted from VDIF to K5 format in real-time (during the observing session). For the data transfer for the Kokee station, we transferred the data with UDP-based protocol “TSUNAMI” after the observing sessions. The average achieved rate of the data transfer was up to 300 Mbps. As most of the INT2 sessions on the Tsukuba-Wetzell baseline are processed in real-time, the processing factors of the session are about 1.00. If we process all of the data with the new processing programs on the Lustre File System after the observing session, the processing factor could be under 0.2.

Table 3. IVS-INT2/INT3 sessions processed in 2011.

Session	Stations	Processed session #	AVG. Processing Factor
IVS-INT2(K)	Ts-Wz	78	0.73
IVS-INT2(I)	Kk-Wz	66	0.54
IVS-INT3(K)	Ts-Wz-Ny	1	1.5
Ts:TSUKUB32, Wz:WETTZELL, Kk:KOKEE, Ny:NYALES20			

## 5. Plans for 2012

The Tsukuba VLBI correlator will process eight JADE sessions, 112 IVS-INT2 sessions and one IVS-INT3 session. We plan to correlate all of the INT2 and INT3 sessions on the Tsukuba-Wetzell baseline with the real-time correlation system.

# Washington Correlator

*Kerry A. Kingham, David M. Hall*

## Abstract

This report summarizes the activities of the Washington Correlator for the year 2011. The Washington Correlator provides up to 80 hours of attended processing per week plus up to 40 hours of unattended operation, primarily supporting Earth Orientation and astrometric observations. In 2011 the major programs supported include the IVS-R4, IVS-INT, CONT11, APSG, and CRF observing sessions.

## 1. Introduction

The Washington Correlator (WACO) is located at and staffed by the U.S. Naval Observatory (USNO) in Washington, DC, USA. The correlator is sponsored and funded by the National Earth Orientation Service (NEOS), which is a joint effort of the USNO and NASA. Dedicated to processing geodetic and astrometric VLBI observations, the facility spent 100 percent of its time on these sessions. All of the weekly IVS-R4 sessions, all of the IVS-INT01 Intensives, the entire CONT11, and the APSG and CRF sessions were processed at WACO. The facility houses a Mark IV Correlator.



Figure 1. The e-transfer corner. A Storage Area Network (large unit) and three Mark 5B+s (far left) collect data over the high-speed networks and write the data out to Mark 5 diskpacks.

## 2. Correlator Operations

- The Washington Correlator continues to operate 80 hours per week with an operator on duty. The correlator has continued to function well unattended, allowing another 40 hours per week, on average, of extra processing. This has also decreased the time it takes to process an R4 or other 24-hour sessions by one day.
- The correlator staff continues the testing and repair of Mark 5 modules. Not only were failed disks replaced, but some modules were upgraded by the replacement of lower capacity disks with higher capacity disks.
- A combination of three new Mark 5B playback units and conversions of existing Mark 5A units to Mark 5B now brings the correlator complement to ten Mark 5Bs and five Mark 5As. Additional Mark 5B+s are used for transfers. The 15 available Mark 5 units allowed processing of CONT11 in a single pass.
- The correlator processed the entire CONT11 session. In addition to the increase in the playback complement, a Storage Area Network (SAN) was added to assist in handling the large volume of electronically transferred observations.
- Intensive observations from Kokee Park and Wettzell were routinely transferred via e-VLBI during 2011. 24-hour sessions from both Hobart antennas, Warkworth, Ny-Ålesund, Fort-aleza, Tsukuba, Aira, Kashima, Chichijima, and Sintotu were also transferred by high-speed networks.
- Correlator time was also spent processing test observations connected with the commissioning of the 12-m antennas at Katherine, Yarragadee, and Warkworth.
- Table 1 lists the experiments processed during 2011.

Table 1. Experiments processed during 2011.

49	IVS-R4 sessions
6	CRF (Celestial Reference Frame)
3	APSG
230	Intensives
15	CONT11

## 3. Staff

The Washington Correlator is under the management and scientific direction of the Earth Orientation Department of the U.S. Naval Observatory. USNO personnel continue to be responsible for overseeing scheduling and processing. During the period covered by this report, a private contractor, NVI, Inc., supplied a contract manager and correlator operators. Table 2 lists staff and their duties.

It is with sadness that we report the death of long-time operator Kenneth Potts on December 27, 2011.

Table 2. Staff.

<b>Staff</b>	<b>Duties</b>
Dr. Kerry Kingham (USNO)	Chief VLBI Operations Division and Correlator Project Scientist
David Hall (USNO)	VLBI Correlator Project Manager
Bruce Thornton (NVI)	Operations Manager
Harvis Macon (NVI)	Lead Correlator Operator
Roxanne Inniss (NVI)	Media Librarian
Kenneth Potts (NVI)	Correlator Operator

#### 4. Outlook

Due to a change in policy by the U.S. Navy, the NVI contract was ended. We are presently trying to move the contracted jobs to Naval Observatory positions. By the end of 2011, the correlator staff had been reduced to three positions, and the backlog of processing and analysis was growing. We hope to eventually add three more people to bring the staffing up to the original level.

During 2012, the processing load should be transferred from the present Mark IV hardware correlator to a DiFX software correlator.



# Data Centers

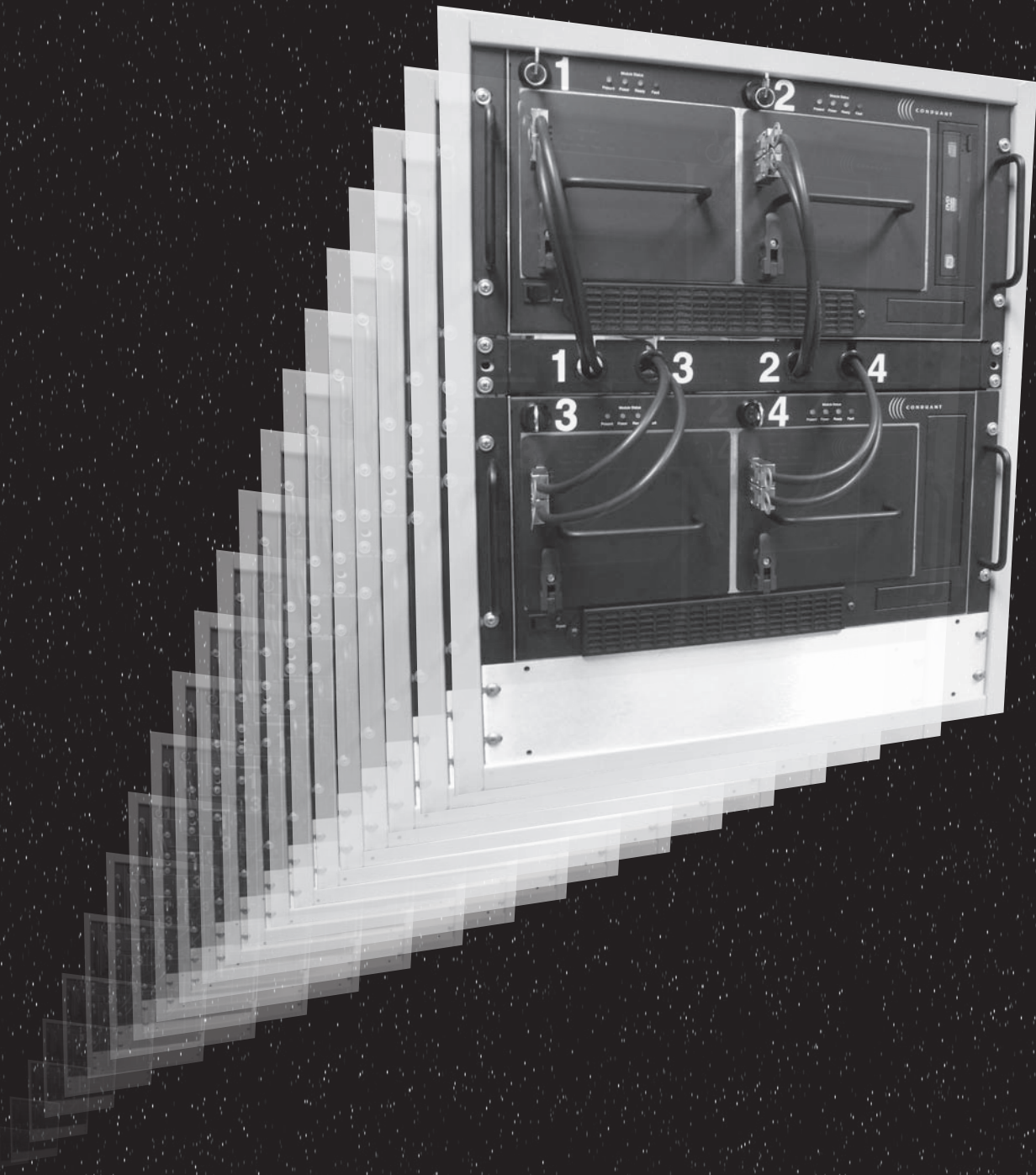

**Data Centers**





# BKG Data Center

*Volkmar Thorandt, Reiner Wojdziak*

## Abstract

This report summarizes the activities and background information of the IVS Data Center for the year 2011. Included are information about functions, structure, technical equipment, and staff members of the BKG Data Center.

## 1. BKG Data Center Functions

The BKG (Federal Agency for Cartography and Geodesy) Data Center is one of the three IVS Primary Data Centers. It archives all VLBI related data of IVS components and provides public access for the community. The BKG Data Center is connected to the OPAR and GSFC CDDIS Data Centers by mirroring the OPAR and the CDDIS file stocks several times per day. The following sketch shows the principle of mirroring:

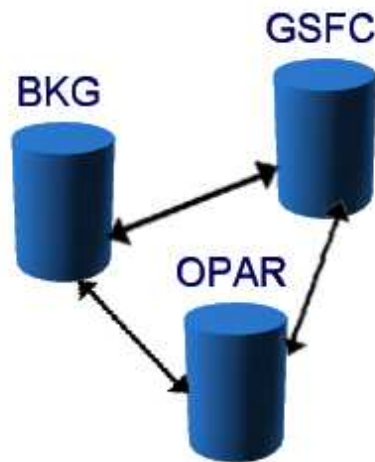

Figure 1. Principle of mirroring

IVS components can choose one of these Data Centers to put their data into the IVS network by using its incoming area, which each of them has at its disposal. The BKG incoming area is protected, and users need to obtain the username and password to get access.

An incoming script is watching the incoming area and checking the syntax of the files sent by IVS components. If it is o.k., the script moves the files into the Data Center directories. Otherwise the files will be sent to a badfile area. Furthermore, the incoming script informs the responsible staff at the Data Center by sending e-mails about its activities. The incoming script is part of the technological unit which is responsible for managing the IVS and the Operational Data Center, and for carrying out the first analysis steps in an automatic manner. All activities are monitored to guarantee data consistency and to control all analysis steps from data arrival to delivery of analysis products to IVS.

Public access to the BKG Data Center is available through FTP and HTTP:

FTP: <ftp://ivs.bkg.bund.de/pub/vlbi/>

HTTP: <http://ivs.bkg.bund.de/vlbi/>

Structure of the BKG IVS Data Center:

```
vlbi/           : root directory
ivs-special/    : special CRF investigations
ivscontrol/     : control files for the data center
ivsdata/        : VLBI observation files
ivsdocuments/   : IVS documents
ivs-iers/       : old IERS solutions
ivsproducts/    : analysis products
  crf/          : celestial frames
  trf/          : terrestrial frames
  eops/         : earth orientation (24h sessions)
  eopi/         : earth orientation (Intensive sessions)
  daily_sinex/ : daily sinex files (24h sessions)
  int_sinex/   : daily sinex files (Intensive sessions)
  trop/        : troposphere
```

## 2. Technical Equipment

DELL Server (SUSE Linux operating system)  
disk space: 500 GBytes (Raid system)  
backup: automatic tape library

## 3. Staff Members

Volkmar Thorandt (coordination, data analysis, data center, volkmar.thorandt@bkg.bund.de)  
Reiner Wojdziak (data center, Web design, reiner.wojdzia@bkg.bund.de)  
Dieter Ullrich (data analysis, data center, dieter.ullrich@bkg.bund.de)  
Gerald Engelhardt (data analysis, gerald.engelhardt@bkg.bund.de)

# CDDIS Data Center Summary for the IVS 2011 Annual Report

*Carey Noll*

## Abstract

This report summarizes activities during the year 2011 and future plans of the Crustal Dynamics Data Information System (CDDIS) with respect to the International VLBI Service for Geodesy and Astrometry (IVS). Included in this report are background information about the CDDIS, the computer architecture, staff supporting the system, archive contents, and future plans for the CDDIS within the IVS.

## 1. Introduction

The Crustal Dynamics Data Information System (CDDIS) has supported the archiving and distribution of Very Long Baseline Interferometry (VLBI) data since its inception in 1982. The CDDIS is a central facility providing users access to data and derived products to facilitate scientific investigation. The CDDIS archives of GNSS (GPS and GLONASS), laser ranging, VLBI, and DORIS data are stored on-line for remote access. Information about the system is available via the Web at the URL <http://cddis.gsfc.nasa.gov>. In addition to the IVS, the CDDIS actively supports other IAG services including the International GNSS Service (IGS), the International Laser Ranging Service (ILRS), the International DORIS Service (IDS), the International Earth Rotation and Reference Systems Service (IERS), and the Global Geodetic Observing System (GGOS) of the IAG. The current and future plans for the system's support of the IVS are discussed below.

## 2. System Description

The CDDIS archive of VLBI data and products is accessible to the public through anonymous ftp.

### 2.1. Computer Architecture

The CDDIS is operational on a dedicated server, [cddis.gsfc.nasa.gov](http://cddis.gsfc.nasa.gov). The system has over 8 Tbytes of on-line disk storage; at this time, over 140 Gbytes are devoted to VLBI activities. The CDDIS is located at NASA GSFC and is accessible to users 24 hours per day, seven days per week.

### 2.2. Staffing

Currently, a staff consisting of one NASA civil service employee and five (one full-time, four part-time) contractor employees supports all CDDIS activities (see Table 1 below).

## 3. Archive Content

The CDDIS has supported GSFC VLBI coordination and analysis activities for the past several years through an on-line archive of schedule files, experiment logs, and data bases in several formats. This archive has been expanded for the IVS archiving requirements.

The IVS Data Center content and structure is shown in Table 2 below. (A figure illustrating

Table 1. CDDIS Staff

Name	Position
Ms. Carey Noll	CDDIS Manager
Dr. Patrick Michael	System Engineer (part-time)
Dr. Maurice Dube	Senior programmer
Mr. Nathan Pollack	Programmer (part-time)
Ms. Lori Tyahla	Programmer (part-time)
Ms. Lisa Lee	Web developer (part-time)

the flow of information, data, and products between the various IVS components was presented in the CDDIS submission to the IVS 2000 Annual Report.) In brief, an incoming data area has been established on the CDDIS host computer, `cddis.gsfc.nasa.gov`. Using specified file names, operation and analysis centers deposit data files and analyzed results to appropriate directories within this filesystem. Automated archiving routines, developed by GSFC VLBI staff, peruse the directories and move any new data to the appropriate public disk area. These routines migrate the data based on the file name to the appropriate directory as described in Table 2. Index files in the main sub-directories under `ftp://cddis.gsfc.nasa.gov/pub/vlbi` are updated to reflect data archived in the filesystem. Furthermore, mirroring software has been installed on the CDDIS host computer, as well as at all other IVS data centers, to facilitate equalization of data and product holdings among these data centers. At this time, mirroring is performed between the IVS data centers located at the CDDIS, the Bundesamt für Kartographie und Geodäsie in Leipzig, and the Observatoire de Paris.

The public filesystem in Table 2 on the CDDIS computer, accessible via anonymous ftp, consists of a data area, which includes auxiliary files (e.g., experiment schedule information, session logs) and VLBI data (in both database and NGS card image formats). A products disk area has also been established to house analysis products from the individual IVS analysis centers as well as the official combined IVS products. A documents disk area contains format, software, and other descriptive files.

#### 4. Data Access

During 2011, over 1600 distinct hosts accessed the CDDIS on a regular basis to retrieve VLBI related files. These users, which include other IVS data centers, successfully downloaded over 80 Gbytes of data and products (1.2 M files) from the CDDIS VLBI archive last year.

#### 5. Future Plans

In early 2012, the CDDIS will move operations to a new distributed, redundant server environment. Users and suppliers of data and product files will see little difference in operations but the system will provide a more secure and stable system for CDDIS operations. The structure of the VLBI data and product archive remained unchanged in this new system configuration.

The CDDIS staff will continue to work closely with the IVS Coordinating Center staff to ensure that our system is an active and successful participant in the IVS archiving effort.

Table 2. IVS Data and Product Directory Structure

Directory	Description
Data Directories	
vlbi/ivsdata/db/ <i>yyyy</i>	VLBI database files for year <i>yyyy</i>
vlbi/ivsdata/ngs/ <i>yyyy</i>	VLBI data files in NGS card image format for year <i>yyyy</i>
vlbi/ivsdata/aux/ <i>yyyy/sssss</i>	Auxiliary files for year <i>yyyy</i> and session <i>sssss</i> ; these files include: log files, wx files, cable files, schedule files, correlator notes
vlbi/raw	Raw VLBI data
Product Directories	
vlbi/ivsproducts/crf	CRF solutions
vlbi/ivsproducts/eopi	EOP-I solutions
vlbi/ivsproducts/eops	EOP-S solutions
vlbi/ivsproducts/daily_sinex	Daily SINEX solutions
vlbi/ivsproducts/int_sinex	Intensive SINEX solutions
vlbi/ivsproducts/trf	TRF solutions
vlbi/ivsproducts/trop	Troposphere solutions
Project Directories	
vlbi/ivs-iers	IVS contributions to the IERS
vlbi/ivs-pilot2000	IVS Analysis Center pilot project (2000)
vlbi/ivs-pilot2001	IVS Analysis Center pilot project (2001)
vlbi/ivs-pilotbl	IVS Analysis Center pilot project (baseline)
vlbi/ivs-pilottro	IVS Analysis Center pilot project (troposphere)
vlbi/ivs-special	IVS special analysis solutions
Other Directories	
vlbi/ivscontrol	IVS control files (master schedule, etc.)
vlbi/ivsdocuments	IVS document files (solution descriptions, etc.)
vlbi/dserver	dserver software and incoming files

# Italy INAF Data Center Report

*M. Negusini, P. Sarti*

## Abstract

This report summarizes the activities of the Italian INAF VLBI Data Center. Our Data Center is located in Bologna, Italy and belongs to the Institute of Radioastronomy, which is part of the National Institute of Astrophysics.

## 1. Introduction

The main analysis activity and storage is concentrated in Bologna, where we store and analyze single databases, using CALC/SOLVE software.

The IRA started to store geodetic VLBI databases in 1989, but the databases archived in Bologna mostly contain data including European antennas from 1987 onward. In particular most of the databases available here have VLBI data with at least three European stations. However, we also store all the databases with the Ny-Ålesund antenna observations. In 2002 we decided to store the complete set of databases available on the IVS data centers, although we limited the time span to the observations performed from 1999 onwards. All the databases have been processed and saved with the best selection of parameters for the final arc solutions. In order to perform global solutions, we have computed and stored the superfiles for all the databases.

In some cases we have introduced GPS-derived wet delays into the European databases (1998 and 1999 EUROPE experiments, for the time being) as if they were produced by a WVR. These databases are available and stored with a different code from the original databases. In order to produce these databases, we have modified DBCAL, and this new version is available to external users.

## 2. Computer Availability and Routing Access

To date, the main computer is a Linux workstation, on which Mark 5 Calc/Solve version 10 was installed and to which all VLBI data analysis was migrated. The Internet address of this computer is sarip.ira.inaf.it. Since 2011 a new server with a storage capacity of 5 TB has been available, and, therefore, all experiments performed in the previous years were downloaded and archived, thus completing the catalog. The older experiments will be analyzed in order to perform global long term analysis. At present, the databases are stored in the following directories:

1 = /data2/dbase2

2 = /geo1/dbase1

3 = /geo1/dbase

4 = /geo1/dbase3

The superfiles are stored in:

/data1/super1

The list of superfiles is stored in the file /data2/mk5/save\_files/SUPCAT. The username for accessing the databases is geo. The password may be requested by sending an e-mail to negusini@ira.inaf.it.

# Data Center at NICT

*Ryuichi Ichikawa, Mamoru Sekido*

## Abstract

The Data Center at the National Institute of Information and Communications Technology (NICT) archives and releases the databases and analysis results processed at the Correlation Center and the Analysis Center at NICT. Regular VLBI sessions of the Key Stone Project VLBI Network were the primary objective of the Data Center. These regular sessions continued until the end of November 2001. In addition to the Key Stone Project VLBI sessions, NICT has been conducting geodetic VLBI sessions for various purposes, and these data are also archived and released by the Data Center.

## 1. Introduction

The IVS Data Center at National Institute of Information and Communications Technology (NICT) archives and releases the databases and analysis results processed by the Correlation Center and the Analysis Center at NICT. Major parts of the data are from the Key Stone Project (KSP) VLBI sessions [1], but other regional and international VLBI sessions conducted by NICT are also archived and released. Since routine observations of the KSP network terminated at the end of November 2001, there have been no additional data from the KSP regular sessions since 2002. In 2009 and 2010, a series of geodetic VLBI sessions were carried out by using the Kashima 34-m, Kashima 11-m, and Koganei 11-m stations to demonstrate precise time comparison. Another series of astronomical VLBI sessions were carried out between the Kashima 34-m and Koganei 11-m stations to monitor the flux densities of radio variable stars using real-time e-VLBI data transfer and processing. In addition, seven geodetic experiments using the two compact VLBI systems with a 1.6-m antenna were also carried out in 2010 [2]. These data sets are also held by our database archives.

The analysis results in SINEX (Solution INdependent EXchange) format, as well as in other formats, are available on the WWW server. Database files of non-KSP sessions, i.e., other domestic and international geodetic VLBI sessions, are also available on the WWW server. Table 1 lists the WWW server locations maintained by the NICT Data Center. In the past, an FTP server was used to provide data files, but it was decided to terminate the FTP service because of the security risks of maintaining an anonymous FTP server. Instead, the [www3.nict.go.jp](http://www3.nict.go.jp) WWW server was prepared to provide large size data files.

Table 1. URL of the WWW server systems.

Service	URL
KSP WWW pages	<a href="http://ksp.nict.go.jp/">http://ksp.nict.go.jp/</a>
IVS WWW mirror pages	<a href="http://ivs.nict.go.jp/mirror/">http://ivs.nict.go.jp/mirror/</a>
Database files	<a href="http://www3.nict.go.jp/aeri/sts/stmg/database/">http://www3.nict.go.jp/aeri/sts/stmg/database/</a>
e-VLBI Sessions	<a href="http://www2.nict.go.jp/aeri/sts/stmg/research/e-VLBI/UT1/">http://www2.nict.go.jp/aeri/sts/stmg/research/e-VLBI/UT1/</a>
Hayabusa Sessions	<a href="http://www2.nict.go.jp/aeri/sts/stmg/research/Navi/HAYABUSA/">http://www2.nict.go.jp/aeri/sts/stmg/research/Navi/HAYABUSA/</a>

The responsibilities for the maintenance of these server machines were moved from the VLBI

research group of NICT to the common division for the institutional network service of the laboratory in 2001 to improve the network security of these systems.

## 2. Data Products

### 2.1. KSP VLBI Sessions

The KSP VLBI sessions were performed with four KSP IVS Network Stations at Kashima, Koganei, Miura, and Tateyama on a daily or bi-daily basis until May 1999. The high-speed ATM (Asynchronous Transfer Mode) network line to the Miura station became unavailable in May 1999, and real-time VLBI observations with the Miura station became impossible. Thereafter, the real-time VLBI sessions were performed with the three other stations. Once every six days (every third session), the observed data were recorded to the K4 data recorders at three stations, and the Miura station participated in the sessions with the tape-based VLBI technique. In this case, the observed data at the three stations other than the Miura station were processed in real-time, and the analysis results were released promptly after the observations completed. A day later, the observed tapes were transported from the Kashima, Miura, and Tateyama stations to the Koganei station for tape-based correlation processing with all six baselines. After the tape-based correlation processing was completed, the data set produced with the real-time VLBI data processing was replaced by the new data set.

In July 2000, unusual site motion of the Tateyama station was detected from the KSP VLBI data series, and the frequency of the sessions was increased from bi-daily to daily on July 22, 2000. The daily sessions were continued until November 11, 2000, and the site motions of the Tateyama and Miura stations were monitored in detail. During the period, it was found that the Tateyama station moved about 5 cm in the northeast direction. The Miura station also moved about 3 cm to the north. The unusual site motions of these two stations gradually settled, and the current site velocities seem to be almost the same as the site velocities before June 2000. By investigating the time series of the site positions, the unusual site motion started sometime between the end of June 2000 and the beginning of July 2000. At the same time, volcanic and seismic activities near the Miyakejima and Kozushima Islands began. These activities are believed to have caused the regional crustal deformation in the area, explaining the unusual site motions at Tateyama and Miura.

### 2.2. Other VLBI Sessions

In addition to the KSP regular VLBI sessions, domestic and international geodetic and astronomical VLBI sessions were conducted by NICT in cooperation with the Geospatial Information Authority of Japan (GSI), the National Astronomical Observatory (NAO), and other organizations. These sessions are listed in Table 2. The recent observed data of these sessions were mainly processed by using the K5 software correlator at NICT either at Koganei or at Kashima or by using a real-time hardware correlator developed by NAO.

In 2011, the operation time of our 34-m antenna was only 364 hours in total. We repaired and maintained several parts of the antenna (i.e., repainting of the main dish and rustproofing of the antenna structure) since the first of January, 2011. The repair was supposed to be finished by the end of March. However, since the  $M_w$  9.0 megaquake hit our antenna on March 11th, 2011, the repair was stopped. The repair was restarted in April, and it was finished at the end of June. After



Table 2. Geodetic VLBI sessions conducted by NICT (since 2005).

Year	exp. names	sessions
2005	Geodetic	c0505 (CONT05, partial participation), GEX13
	Hayabusa	14 sessions
2006	Geodetic	GEX14, viepr2, CARAVAN (3 sessions)
	Spacecraft	Geotail : 1 session
	Pulsar	1 session
2007	Ultra Rapid e-VLBI	15 times, 29 sessions
	Time Transfer	4 sessions, 12 days in total
	Cs-Gas-Cell	1 session
	Spacecraft	Hayabusa: 1 session
2008	Ultra Rapid e-VLBI	8 times, 33 sessions
	Time Transfer	26 sessions
	Variable Star e-VLBI	31 sessions
2009	e-VLBI	15 sessions, 90.5 hours in total
	IVS	12 sessions, 332 hours in total
	Time Transfer	9 sessions, 72 hours in total
	VERA	16 sessions, 149 hours in total
	Survey	26 sessions, 276 hours in total
2010	IVS	38 sessions, 442 hours in total
	Radio astronomy	34 sessions, 324 hours in total
	Spacecraft (IKAROS, UNITEC-1, QZSS)	33 sessions, 259 hours in total
	domestic geodetic	13 sessions, 94 hours in total
	Time Transfer	9 sessions, 86 hours in total
	e-VLBI	9 sessions, 27 hours in total
2011	IVS	2 sessions, 48 hours in total
	Radio astronomy	100 hours in total
	earthquake damage investigation	216 hours in total

the repair, we investigated the earthquake damage carefully. Unfortunately, the gear reducers, the power and helium plumbing, the azimuth track wear strips, and one azimuth wheel were damaged. We are going to fix them as soon as possible in this fiscal year.

### 3. Staff Members

The Data Center at NICT is operated and maintained by the Space-Time Standards Group at the Kashima Space Research Center, NICT. The staff members are listed in Table 3.

Table 3. Staff members of the Space-Time Measurements Group, KSRC, NICT.

Name	Main Responsibilities
ICHIKAWA Ryuichi	Frequency and Time Transfer using compact VLBI system
SEKIDO Mamoru	Responsible for e-VLBI sessions
HASEGAWA Shingo	System Engineer

#### 4. Future Plans

The IVS Data Center at NICT will continue its service and will archive and release the analysis results accumulated by the Correlation Center and the Analysis Center at NICT. In addition, a number of VLBI sessions will be conducted for the purposes of various technology developments.

#### References

- [1] Special issue for the Key Stone Project, J. Commun. Res. Lab., Vol. 46, No. 1, March 1999.
- [2] Hobiger T., Takiguchi H., Ichikawa R., Sekido M., Koyama Y., and Kondo T., Analysis Center at NICT, *International VLBI Service for Geodesy and Astrometry 2010 Annual Report*, pp. 229-232, C2011.

# Paris Observatory (OPAR) Data Center

*Christophe Barache, Sébastien Lambert*

## Abstract

This report summarizes the OPAR Data Center activities in 2011. Included is information about functions, architecture, status, future plans, and staff members of OPAR Data Center.

## 1. OPAR Data Center Functions

The Paris Observatory (OPAR) has provided a Data Center for the International VLBI Service for Geodesy and Astrometry (IVS) since 1999. The OPAR, as well as CDDIS and BKG, is one of the three IVS Primary Data Centers. Their activities are done in close collaboration for collecting files (data and analysis files) and making them available to the community as soon as they are submitted.

The three data centers have a common protocol and each of them:

- has the same directory structure (with the same control file),
- has the same script,
- is able to receive all IVS files (auxilliary, database, products, documents),
- mirrors the other ones every three hours,
- gives free FTP access to the files.

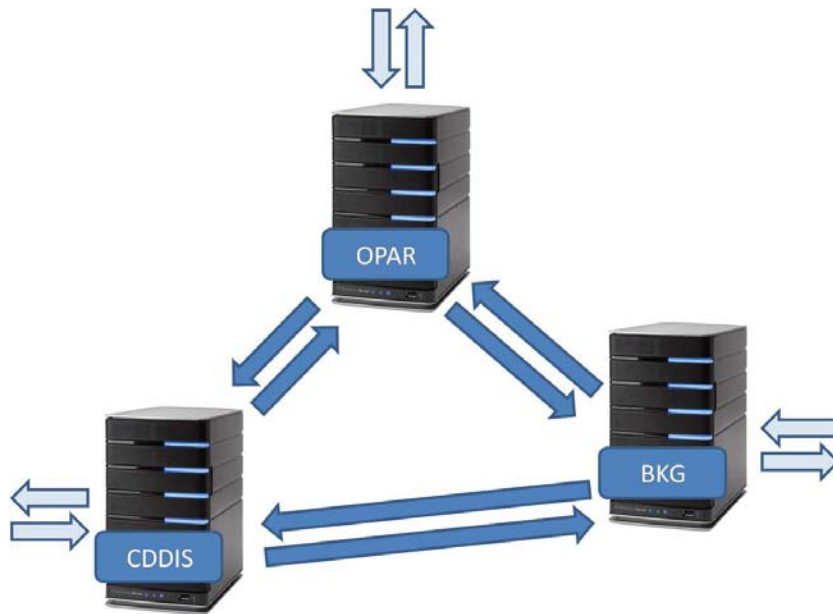

Figure 1. Mirroring among the primary IVS Data Centers.

This protocol gives the IVS community transparent access to a data center through the same directory structure and permanent access to files in case of a data center breakdown.

## 2. Architecture

To be able to put a file into a data center, operational and analysis centers have to be registered by the IVS Coordinating Center. The file names have to conform to the naming convention. A script checks the file and puts it into the right directory. The script undergoes permanent improvement and takes into account the IVS components' requests.

The structure of IVS Data Centers is:

```

ivscontrol/      : provides the control files needed by the data center
                  (session code, station code, solution code...)
ivscontrol_new/  : temporary test directory
ivscontrol_old/  : temporary test directory
ivsdocuments/    : provides documents and descriptions about IVS products
ivsdata/         : provides files related to the observations:
  aux/           : auxilliary files (schedule, log...)
  db/            : observation files in data-base CALC format
  ngs/           : observation files in NGS format
  sinex/         : observation files in SINEX format
ivsproducts/     : provides results from Analysis Center:
  eopi/          : Earth Orientation Parameters, Intensive sessions
  eops/          : Earth Orientation Parameters, 24-hour sessions
  crf/           : Celestial Reference Frame
  trf/           : Terrestrial Reference Frame
  daily_sinex/   : Time series solutions in SINEX format of Earth
                  orientation and site positions
  int_sinex/     : Daily Intensive solution in SINEX format, mainly
                  designed for combination
  trop/          : Tropospheric time series (starting July 2003)
ivs-iers/        : provides products for IERS Annual Report
ivs-pilot2000/   : provides products of 2000 for special investigations
ivs-pilot2001/   : provides products of 2001 for special investigations
ivs-pilottro/    : provides tropospheric time series for Pilot Project
                  (until June 2003)
ivs-pilotbl/     : provides baseline files
ivs-special/     : specific studies
raw/             : original data (not writable at OPAR Data Center)

```

## 3. Current Status

The OPAR Data Center is operated currently on a PC Server (PowerEdge 2800 - Xeron 3.0 GHz) located at Paris Observatory running the Fedora Linux operating system.

To make all IVS products available on-line, the disk storage capacity was significantly increased. The server is now equipped with a RAID 3-TB disk extensible up to 4.7 TB.

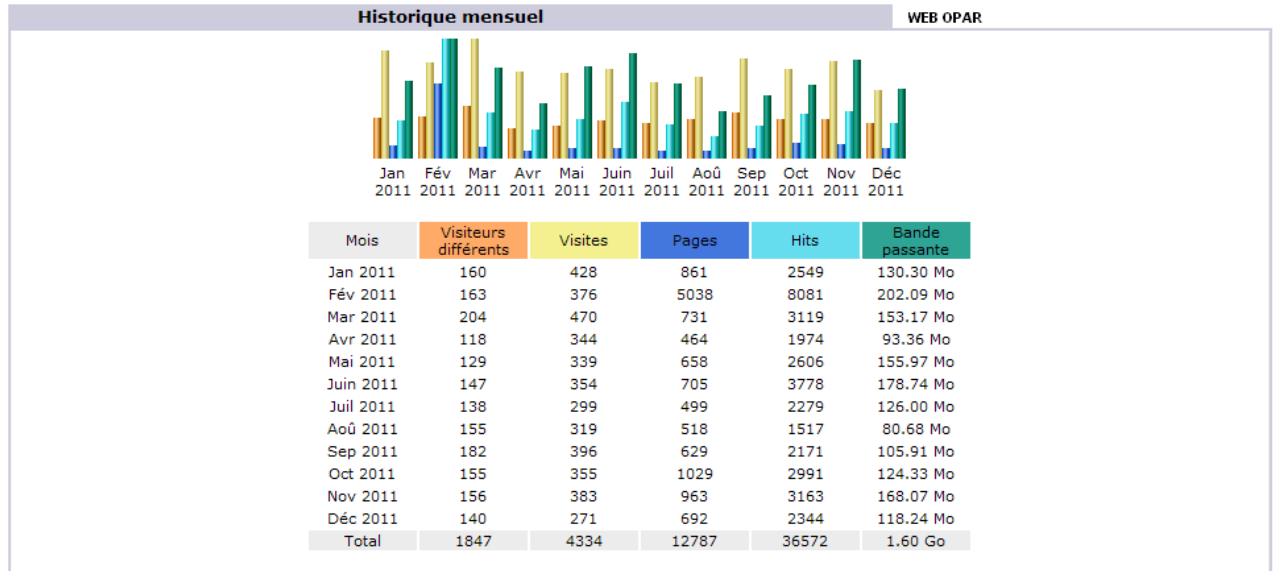

Figure 2. Monthly access of the OPAR Data Center during 2011. For each month listed in column 1, columns 2 through 6 show the number of different visitors, the total number of visits, the number of pages viewed, the number of hits, and the downloaded bandwidth in Megabytes (Mo) or Gigabytes (Go).

The OPAR server is accessible 24 hours per day, seven days per week through Internet connection with 2Mbit/s rate. Users can get the IVS products by using the FTP protocol. Access to this server is free for users.

FTP access:

```
ivsopar.obspm.fr
username: anonymous
password: your e-mail
cd vlbi (IVS directory)
```

In 2011, 25 different users regularly put and got data on the FTP OPAR ivsincoming. There were also 3273 distinct users of the Web OPAR server.

#### 4. Future Plans

The OPAR staff will continue to work with the IVS community and closely collaborate with the two other Primary Data Centers in order to provide public access to all VLBI-related data.

To obtain information about the OPAR Data Center please contact: [ivs.opa@obspm.fr](mailto:ivs.opa@obspm.fr)



# Analysis Centers

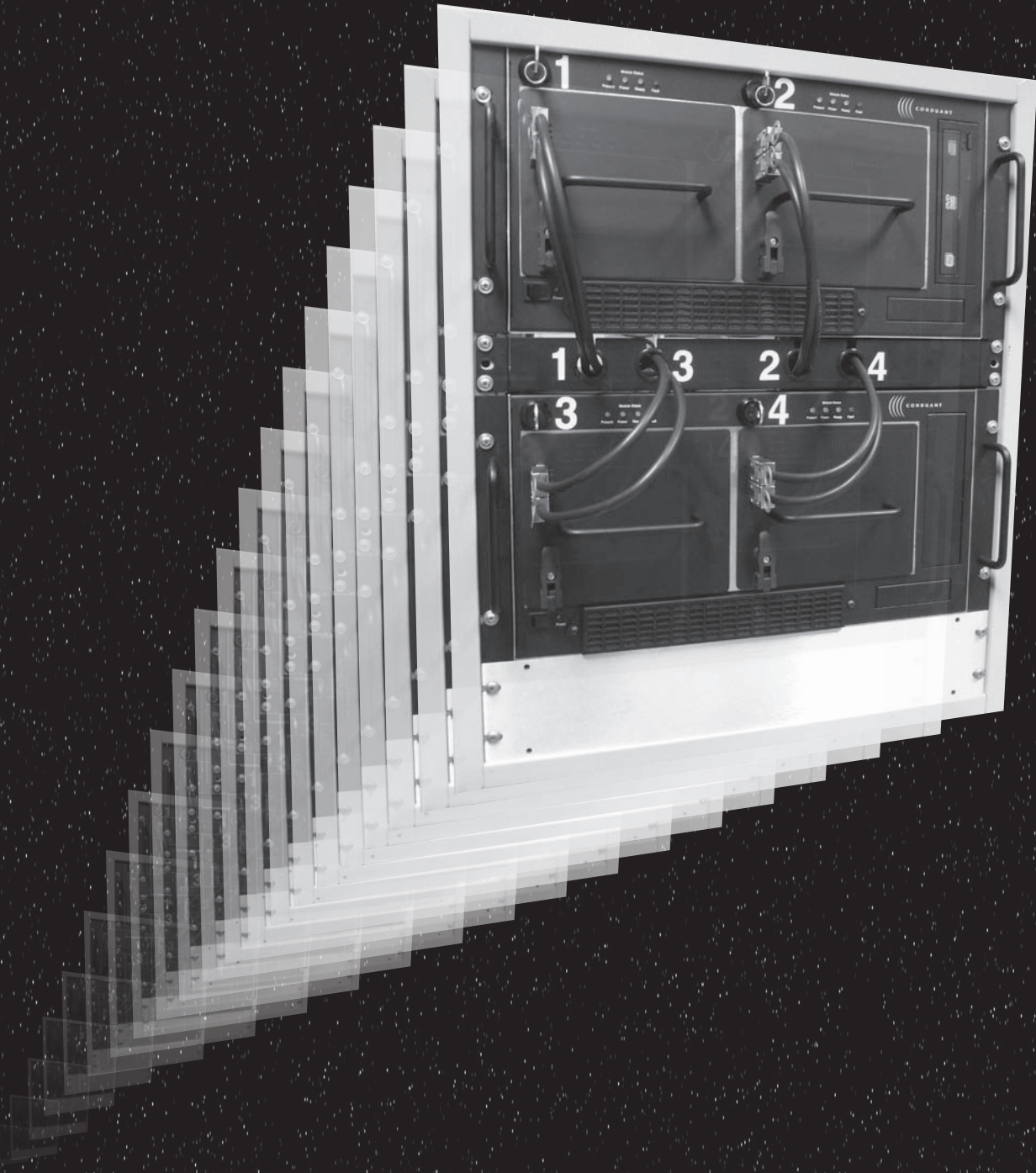

**Analysis Centers**





# Analysis Center of Saint Petersburg University

*Dmitriy Trofimov, Veniamin Vityazev*

## Abstract

This report briefly summarizes the activities of the Analysis Center of Saint Petersburg University during 2011. Changes which happened, as well as our future plans, are described.

## 1. Introduction

The Analysis Center of Saint Petersburg University (SPU AC) was established in the Sobolev Astronomical Institute of the SPb University in 1998. The main activity of the SPU AC for the International VLBI Service before 2007 consisted of routine processing of 24-hour and 1-hour observational sessions for obtaining Earth Orientation Parameters (EOP) and rapid UT1-UTC values, respectively. Due to staff changes in 2007 we had a gap in our submissions to IVS. In 2008 we resumed submitting results of 24-hour session processing. During 2011 the activities of the SPU AC continued unchanged.

## 2. Staff

The lecturer in astronomy of Saint Petersburg University, Dmitriy Trofimov, was in charge of the routine processing of the VLBI observations. General coordination and support for the activities of the SPU AC at the Astronomical Institute was performed by Prof. Veniamin Vityazev.

## 3. Activities in 2011

- In 2011 we continued the work resumed in 2008. There were breaks in the work due to technical reasons. The routine estimation of the five Earth Orientation Parameters was performed. The OCCAM software package (version 6\_2) was used for current processing of VLBI data [1]. The time series is named spu00004.eops. It includes data obtained by the IRIS-A, NEOS-A, R1, and R4 observing programs, and it covers 24 years of observations (from January 2, 1989 until the end of 2011). The total number of processed experiments is about 1730, of which 90 VLBI sessions were processed in 2011. Our experience and the equipment of the Analysis Center was used for giving lectures and practical work on the basics of radio interferometry for the university students. In 2011, with the purpose of giving students education in practical applications, we published a training manual on modern astrometry, in which the VLBI technique is considered [2].

In 2011, the work of the SPU AC was supported by the project “Kinematic and Dynamic Astronomy” (a grant of the President of the Russian Federation for leading scientific schools) as well as by the project “Acquisition and analysis of time-series in astronomy and the study of astronomical catalogs” (an SPU grant for fundamental research) and “GLONASS, GPS and VLBI observations as the basis of astronomical, gravimetric and geodynamic studies” (an SPU grant for fundamental research).

- All parameters were adjusted using the Kalman filter technique. For all stations (except the reference station), the wet delay, clock offsets, clock rates, and troposphere gradients were

estimated. Troposphere wet delay and clock offsets were modeled as a stochastic process such as a random walk. The clock rates and the troposphere gradients were considered to be the constant parameters.

- The main details of the preparation of the EOP time series spu00004.eops are summarized below:
  - Data span: 1989.01–2011.12
  - CRF: fixed to ICRF-Ext.2
  - TRF: VTRF2005 was used as an a priori TRF
  - Estimated parameters:
    1. EOP:  $x, y, UT1 - UTC, d\psi, d\varepsilon$ ;
    2. troposphere: troposphere gradients were estimated as constant parameters, and wet troposphere delays were modeled as a random walk process;
    3. station clocks were treated as follows: offset as a random walk process, rate as a constant.
  - nutation model: IAU 1980
  - mapping function: VMF1
  - technique: Kalman filter
  - software: OCCAM v.6\_2

#### 4. Future Plans

In 2012 we are going to continue our regular processing of the results of the VLBI sessions as well as giving lectures and the practical work for the students within a special course on radio astrometry which is included in the systematic curriculum of astronomical education at SPb University.

#### References

- [1] O. Titov, V. Tesmer, J. Boehm, OCCAM v. 6. 0 Software for VLBI Data Analysis, In International VLBI Service for Geodesy and Astrometry 2004 General Meeting Proceedings, N. R. Vandenberg and K. D. Baver (eds.), NASA/CP-2004-212255, pp.267-271, 2004.
- [2] V.Vityazev, I.Guseva, V.Kiyaev, M.Mishchenko, O. Titov, A.Tsvetkov. Celestial and Terrestrial Coordinates (In Russian), Manual on Astrometry, 301 p., SPb University, 2011.

# Geoscience Australia Analysis Center

*Oleg Titov, Laura Stanford*

## Abstract

This report gives an overview of the activities of the Geoscience Australia IVS Analysis Center during 2011.

## 1. General Information

The Geoscience Australia (GA) IVS Analysis Center is located in Canberra. The Geodesy group operates as a part of the Mineral and Natural Hazard Division (MNHD).

## 2. Component Description

Currently the GA IVS Analysis Center contributes nutation offsets, EOP, and EOP rates on a regular basis for IVS-R1 and IVS-R4 networks and their predecessors (IRIS-A and NEOS-A). The EOP time series are available for 1983 to 2011. The CRF catalogs using a global set of VLBI data since 1979 are regularly submitted to the IVS archives.

## 3. Staff

- Dr. Oleg Titov - project manager
- Dr. Laura Stanford - VLBI scientist

## 4. Current Status and Activities

Several CRF solutions have been prepared using the OCCAM 6.2 software. The last solution was uploaded in January 2011. VLBI data comprising 4,109 daily sessions from 25-Nov-1979 to 10-Oct-2011 have been used to compute several global solutions with different sets of reference radio sources. This includes 5,257,804 observational delays from 2,881 radio sources observed by 60 VLBI stations [1].

Station coordinates were also estimated using NNR and NNT constraints. The long-term time series of the station coordinates have been established to estimate the corresponding velocities for each station. The tectonic motion for the Gilcreek VLBI site after the Denali earthquake was modelled using an exponential function typical of post-seismic deformation [2]. The tectonic motion of the Tigoconc (2010 year) and Tsukub32 (2011 year) VLBI sites after the strong earthquakes is currently under study.

The adjustment was made by least squares collocation [3], which considers the clock offsets, wet troposphere delays, and tropospheric gradients as stochastic parameters with a priori covariance functions. The gradient covariance functions were estimated from GPS hourly values [4].

A paper on the secular aberration drift has been prepared in collaboration with colleagues from the IVS Analysis Center of Paris Observatory [5]. A dipole systematic effect, with magnitude  $6.4 \pm 1.5 \mu\text{as/yr}$ , was found using the individual proper motions of the 555 reference radio sources

with the CALC/SOLVE software. This corresponds to the Galactocentric acceleration of  $(3.2 \pm 0.7) \times 10^{-13}$  km/s<sup>2</sup>, in good agreement with the theoretical predictions.

## 5. Geodetic Activity of the Australian Radio Telescopes

During 2011, three Australian radio telescopes – Hobart26, Hobart12 operated by the University of Tasmania (UTAS) and Parkes, operated by the Australia Telescope National Facility (ATNF) – started regular geodetic VLBI observations for different IVS programs.

The Parkes 64-meter telescope participated in six geodetic VLBI sessions in 2011 for improvement of the ITRF and the ICRF in the Southern Hemisphere. This program is undertaken in cooperation with ATNF and UTAS.

## 6. Optical Spectroscopic Observations of the Reference Radio Sources

A program for optical identification and spectroscopy of the reference radio sources has continued [6]. During 2011, five large optical facilities were used for observing optical spectra of the reference radio sources to determine their red shifts. This list comprises two 8-meter Gemini telescopes in Chile (projects GS-2011A-Q-89 and GS-2011B-Q-94) and Hawaii (project GN-2011B-Q-109), a 6-meter telescope in Russia operated by the Special Astrophysical Observatory, a 3.58-meter New Technology Telescope (NTT) in Chile, operated by the European Space Observatory (project 088.A-0021(A)), and a 2-meter Nordic Optical Telescope (NOT). The goal of this work is to identify the radio sources regularly observed for the geodetic and astrometric VLBI programs. An international team of scientists participated in this program. A paper describing the new set of red shifts is in preparation.

During the new five-night observing run, several faint quasars were completely resolved from the obscuring bright star due to a more stable atmosphere (0905-202, 1123-356, 2300-307). Figures 1 and 2 show a sky field around the 2300-307 source observed at NTT in August 2010 and December 2011. The bright star in the image center in Figure 1 has a size of 4 arcseconds obscuring the quasar separated by 4 arcseconds from the star. Under better sky conditions the visible disk of the bright star in the image center has a smaller size in Figure 2 (about 2 arcseconds). Therefore, the faint quasar in Figure 2 is becoming clearly visible.

## 7. New Staff Member

Dr Laura Stanford joined the geodetic group of Geoscience Australia in October 2011.

## Acknowledgements

Two observers (Oleg Titov from GA and David Jauncey from ATNF) were supported by a travel grant from the Access to Major Research Facilities Program (AMRFP) to travel to Russia to the 6-meter telescope in August 2011.

This report has been published with the permission of the CEO, Geoscience Australia.

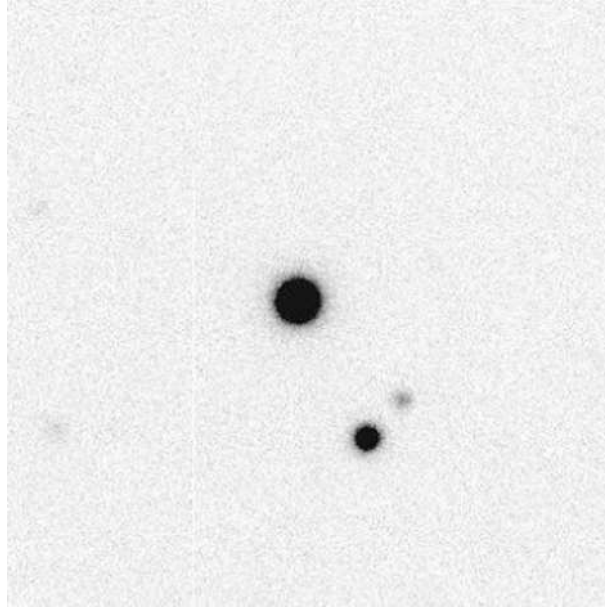

Figure 1. NTT image of the sky field around the quasar 2300-307 made in August 2010 at a visual field of about 2 arcseconds. The bright star in the image center completely obscures the quasar due to the large size of the visible disk (4 arcseconds).

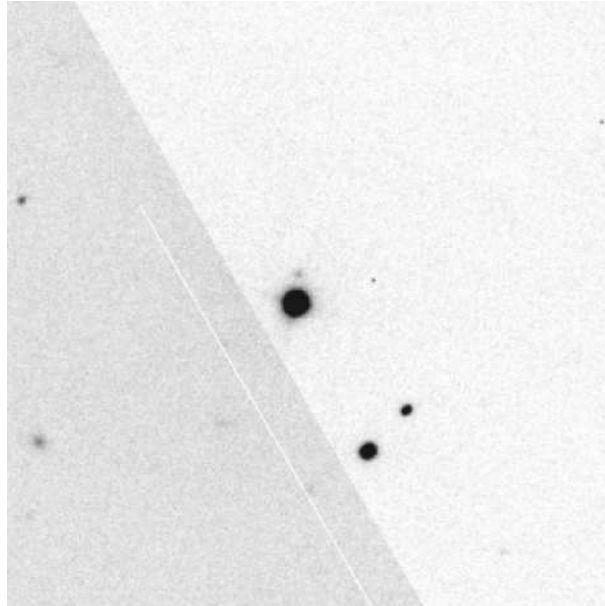

Figure 2. NTT image of the sky field around the quasar 2300-307 made in December 2011 at a visual field of about 0.5 arcseconds. The bright star in the image center has a visible disk two times smaller than in Figure 1, disclosing the faint quasar (22nd magnitude) separated by 4 arcseconds from the star.

## References

- [1] Titov, O., Systematic effects in the radio source proper motion, in: Proceedings of the 19th European VLBI for Geodesy and Astrometry Meeting, Bordeaux, G. Bourda, P. Charlot, and A. Collioud (eds.), 14–18, 2009.
- [2] Titov, O., P. Tregoning, Post-seismic motion of the Gilcreek geodetic sites following the November, 2002 Denali Earthquake, in: International VLBI Service for Geodesy and Astrometry 2004 General Meeting Proceedings, NASA/CP–2004-212255, N. R. Vandenberg and K. D. Baver (eds.), 496–500, 2004.
- [3] Titov, O., Estimation of subdiurnal tidal terms in UT1-UTC from VLBI data analysis, in: IERS Technical Notes 28, B. Kolaczek, H. Schuh, and D. Gambis (eds.), 11–14, 2000.
- [4] Haas, R., private communication.
- [5] Titov, O, S. Lambert, A.-M. Gontier, VLBI measurement of secular aberration drift. AA, 529, A91, 2011.
- [6] Titov, O., D. Jauncey, H. Johnston, R. Hunstead and L. Christensen, Optical Spectra of the southern hemisphere flat-spectrum ICRF radio sources, AJ, 142, 165, 2011.

# Report for 2011 from the Bordeaux IVS Analysis Center

*Patrick Charlot, Antoine Bellanger, Géraldine Bourda, Arnaud Collioud, Alain Baudry*

## Abstract

This report summarizes the activities of the Bordeaux IVS Analysis Center during the year 2011. The work focused on (i) regular analysis of the IVS-R1 and IVS-R4 sessions with the GINS software package; (ii) systematic VLBI imaging of the RDV sessions and calculation of the corresponding source structure index and compactness values; (iii) imaging of the sources observed during the 2009 International Year of Astronomy IVS observing session; and (iv) continuation of our VLBI observational program to identify optically-bright radio sources suitable for the link with the future Gaia frame. Also of importance is the enhancement of the *IVS Live* Web site which now comprises all IVS sessions back to 2003, allowing one to search past observations for session-specific information (e.g. sources or stations).

## 1. General Information

The “Laboratoire d’Astrophysique de Bordeaux” (LAB), formerly Bordeaux Observatory, is located in Floirac, near Bordeaux, in the southwest of France. It is funded by the University of Bordeaux and the CNRS (“Centre National de la Recherche Scientifique”). VLBI activities are primarily developed within the M2A team (“Météologie de l’espace, Astrodynamique, Astrophysique”).

The contribution of the Bordeaux group to the IVS has been mostly concerned with the maintenance, extension, and improvement of the International Celestial Reference Frame (ICRF). This includes regular imaging of the ICRF sources and evaluation of their astrometric suitability, as well as developing specific VLBI observing programs for enhancing the celestial reference frame.

In addition, the group is in charge of the VLBI component in the multi-technique GINS software package [1] as part of a collaborative effort within the French “Groupe de Recherches de Géodésie Spatiale” (GRGS) to combine VLBI and space geodetic data (SLR, GPS, DORIS) at the observation level. This effort also involves space geodesy groups in Toulouse, Grasse, and Paris.

## 2. Description of the Analysis Center

The Bordeaux IVS group routinely analyzes the weekly IVS-R1 and IVS-R4 sessions with the GINS software package. During the past year, weekly normal equations for all such sessions in 2011 (with 6-hour EOP resolution) have been produced and integrated in the multi-technique solutions derived by the GRGS within the framework of the “Combination at the Observation Level” (COL) Working Group. The CONT08 session was also reanalyzed in the same way. Specific studies were conducted to compare different analysis strategies for the EOP determination and to test the impact on the analysis of new stations and of stations displaced by earthquakes. Finally, a pipeline was developed to characterize the observing sessions in a graphical form.

The group is also focused on imaging the ICRF sources on a regular basis by systematic analysis of the data from the RDV sessions which are conducted six times a year. This analysis is carried out with the AIPS and DIFMAP software packages. The aim of such regular imaging is to characterize the astrometric suitability of the sources based on the so-called “structure index”, and to compare source structural evolution and positional instabilities. Such studies are essential for identifying sources of high astrometric quality, for example for the ICRF2 [2] or the future Gaia link.

### 3. Scientific Staff

During the past year, there were no changes in the IVS staff. In all, five individuals contributed to IVS analysis and research activities during 2011. A description of what each person worked on, along with the time spent on these activities, is given below.

- Patrick Charlot (20%): overall responsibility for Analysis Center work and data processing. His research interests include the ICRF densification, extension, and link to the Gaia frame, studies of source structure effects in astrometric VLBI data, and astrophysical interpretation.
- Antoine Bellanger (80%): engineer with background in statistics and computer science. His tasks are to process VLBI data with GINS and to develop procedures and analysis tools to automate such processing. He is also the Web master for the M2A group.
- Géraldine Bourda (50%): astronomer in charge of developing the VLBI part of GINS and responsible for the analysis results derived from GINS. She also leads a VLBI observational program for linking the ICRF and the future Gaia frame.
- Arnaud Collioud (100%): engineer with background in astronomy and interferometry. His tasks are to image the sources in the RDV sessions using AIPS and DIFMAP, to develop the Bordeaux VLBI Image Database and *IVS Live* tool, and to conduct VLBI2010 simulations.
- Alain Baudry (10%): radioastronomy expert with specific interest in radio source imaging and astrometric VLBI. Professor Emeritus and with a part-time ESO contract.

### 4. Analysis and Research Activities during 2011

As noted above, a major activity of the Bordeaux group consists of imaging the sources observed during the RDV sessions on a systematic basis. During 2011, three such sessions were processed (RDV80, RDV82, and RDV84), resulting in 532 VLBI images at either X or S band for 213 different sources. The imaging work load has been shared with USNO since 2007 (starting with RDV61): the USNO group processes the odd-numbered RDV sessions while the Bordeaux group processes the even-numbered ones. The VLBI images are used in a second stage to derive structure correction maps and visibility maps along with values for structure indices and source compactness (see [3, 4] for a definition of these quantities) in order to assess astrometric source quality. All such information is made available through the Bordeaux VLBI Image Database (BVID)<sup>1</sup>. At present, the BVID comprises a total of 3181 VLBI images for 1075 different sources (with links to an additional 7851 VLBI images from the Radio Reference Frame Image Database of USNO at either S, X, K, or Q band) along with 11,032 structure correction maps and as many visibility maps.

Another major piece of work that took place during the past year was the analysis of the International Year of Astronomy 2009 (IYA2009) specific IVS session [5] with the aim of imaging the sources. This session, which was conducted on 18 November 2009, was remarkable in that it used a 32-station network and observed 243 of the 295 ICRF2 defining sources. Analysis of such a large data set required modifications of the AIPS software package so that it can handle that many stations. In all, 232 sources were successfully imaged, a sample of which is shown in Figure 1. Most of the images show very compact structures, as expected for defining sources. This property will be assessed in a more quantitative way in the future by calculating source structure indices.

---

<sup>1</sup>The BVID may be accessed at <http://www.obs.u-bordeaux1.fr/BVID>



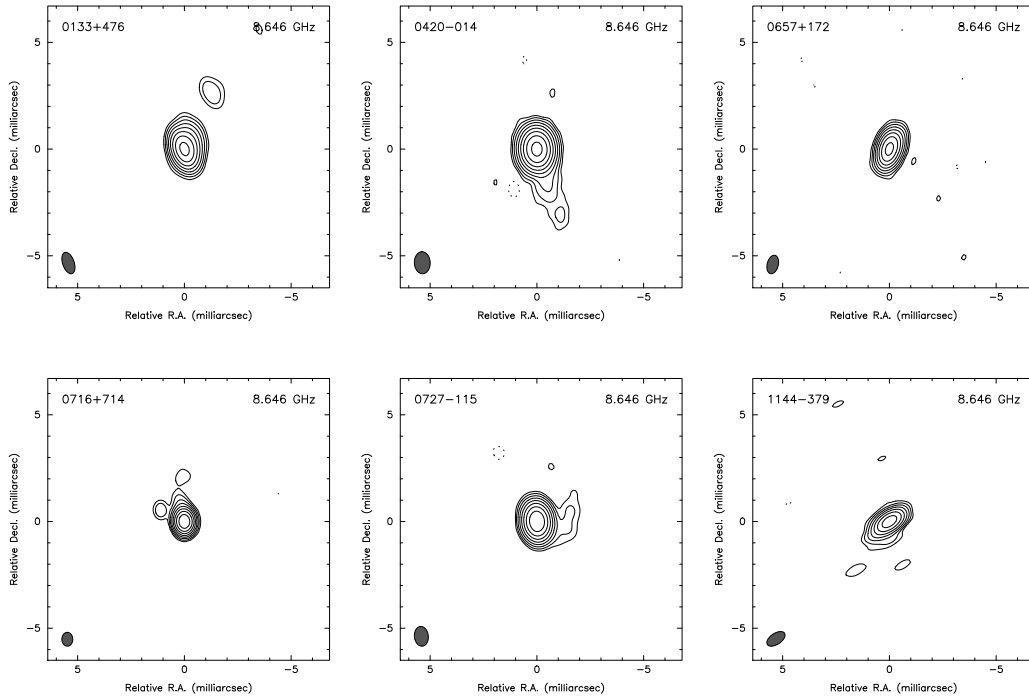

Figure 1. VLBI images at X band for six ICRF2 defining sources with declination ranging from  $-40^\circ$  to  $+70^\circ$  (0133+476, 0420-014, 0657+172, 0716+714, 0727-115, and 1144-379). These sources were observed during the IYA2009 session organized by IVS on 18 November 2009 with a 32-station VLBI network.

On the observational side, the group leads a project to identify and characterize appropriate radio sources to align the ICRF and the future Gaia optical frame. To this end, dedicated VLBI imaging observations of a sample of 395 optically-bright radio sources have been conducted, beginning in 2008 [6, 7]. The last set of sources (75 sources) was observed in March 2011 during a 38-hour long experiment combining 15 stations from the European VLBI Network (EVN) and the Very Long Baseline Array (VLBA) (as for previous experiments). All data sets have been analyzed, the results of which will be presented at the upcoming IVS General Meeting. In all, 250 sources have been successfully imaged, and roughly half of them show the required properties in terms of astrometric suitability. Additionally, we are examining the ICRF2 to identify those sources that also meet the criteria for the alignment. Preliminary results indicate that about 200 of them are in this case [8]. Hence, we anticipate that ultimately there should be more than 300 sources to align the two frames, a similar number to the number of defining sources in the ICRF2.

## 5. Dissemination and Outreach

During the past year, the *IVS Live* Web site [9] was updated on a regular basis and enhanced. In particular, all IVS sessions back to 2003 have been added to the database. With this addition, there is now a total of 4,834 IVS sessions available. These sessions involved 63 stations and observed 1,633 sources. As described in [9], *IVS Live* allows one to monitor IVS sessions in real time and view

source images but also to search for specific information about sources and stations in past IVS sessions. Monitoring of the connections showed that there were about 1,500 visits from around the world during 2011, with at least half of them coming from different individuals. Locally, the Web site was presented to the public during an open day session at the Observatory on 15 May 2011.

## 6. Outlook

Our plans for the coming year are focused on moving towards operational analysis of the IVS-R1 and IVS-R4 sessions with the GINS software package. Additionally, we are considering a specific analysis for estimating time series of radio source positions. Imaging of the RDV sessions and evaluation of the astrometric suitability of the sources will continue along the same lines. On the observational side, dedicated astrometric observations of the  $\sim 125$  sources that are deemed to be suitable for the Gaia link (see Section 4) will be considered. A proposal will be submitted to the EVN and the VLBA to this end. Furthermore, we plan to make a complete assessment of all 3,400 ICRF2 sources for the same purpose. The list of targets for the Gaia link will then be finalized, and we will ask IVS to strengthen observations of these sources. Finally, we will also prepare plans for monitoring such sources during the Gaia mission, which will be launched the year after (in 2013).

## References

- [1] Bourda, G., Charlot, P., Biancale, R.: 2007, GINS: A New Tool for VLBI Geodesy and Astrometry, 18th EVGA Working Meeting, Eds. J. Böhm, A. Pany and H. Schuh, IGG Vienna, p. 59–63.
- [2] IERS Technical Note 35: 2009, The Second Realization of the International Celestial Reference Frame by Very Long Baseline Interferometry, Eds. A. L. Fey, D. Gordon and C. S. Jacobs, Frankfurt am Main: Verlag des Bundesamts für Kartographie und Geodäsie, 204 pages.
- [3] Fey, A. L., Charlot, P.: 1997, VLBA Observations of Radio Reference Frame Sources. II. Astrometric Suitability Based on Observed Structure, *ApJS*, 111, pp.95–142.
- [4] Charlot, P.: 2008, Astrophysical Stability of Radio Sources and Implication for the Realization of the Next ICRF, 5th IVS General Meeting, St Petersburg, Eds. A. Finkelstein and D. Behrend, p. 345–354.
- [5] Charlot, P., Bellanger, A., Bourda, G., Collioud, A., Zhang, M., Baudry, A.: 2010, Report for 2009 from the Bordeaux IVS Analysis Center, IVS 2009 Annual Report, Eds. D. Behrend and K. D. Baver, NASA/TP-2010-215860, p. 213–216.
- [6] Charlot, P., Bellanger, A., Bourda, G., Collioud, A., Zhang, M., Baudry, A.: 2009, Bordeaux Observatory Analysis Center Report, IVS 2008 Annual Report, Eds. D. Behrend and K. D. Baver, NASA/TP-2009-214183, p 246–249.
- [7] Charlot, P., Bellanger, A., Bourda, G., Collioud, A., Zhang, M., Baudry, A.: 2011, Report for 2010 from the Bordeaux IVS Analysis Center, IVS 2010 Annual Report, Eds. D. Behrend and K. D. Baver, NASA/TP-2011-215880, p. 179–182.
- [8] Bourda, G., Charlot, P.: 2011, Plans for an accurate alignment of the VLBI frame and the future Gaia frame, *Journées Systèmes de référence spatio-temporels 2011*, Eds. H. Schuh, S. Böhm, T. Nilsson and N. Capitaine (in press).
- [9] Collioud, A.: 2011, IVS Live: All IVS on your desktop, *Proceedings of the 20<sup>th</sup> Meeting of the European VLBI Group for Geodesy and Astronomy*, Eds. W. Alef, S. Bernhart and A. Nothnagel, Universität Bonn, Institut für Geodäsie und Geoinformation, Schriftenreihe 22, p. 14–18.

# BKG/DGFI Combination Center Annual Report 2011

*Sabine Bachmann, Michael Lösler, Robert Heinkelmann, Michael Gerstl*

## Abstract

This report summarizes the activities of the BKG/DGFI Combination Center in 2011 and outlines the planned activities for the year 2012. The main focus was to stabilize outlier detection and to update the Web presentation of the combined products.

## 1. General Information

The BKG/DGFI Combination Center was established in October 2008 as a joint effort of the Federal Agency for Cartography and Geodesy (Bundesamt für Kartographie und Geodäsie, BKG) and the German Geodetic Research Institute (Deutsches Geodätisches Forschungsinstitut, DGFI). The participating institutions, as well as the tasks and the structure of the IVS Combination Center, have been described in [5]. The tasks comprise quality control and a timely combination of the session-based intermediate results of the IVS Analysis Centers into a final combination product (e.g., Earth Orientation Parameters (EOP)). In coordination with the IVS Analysis Coordinator, the combination results will be released as official IVS products. The Combination Center is also expected to contribute to the generation of the official IVS input to any ITRF activities. These tasks are performed on an operational basis.

## 2. Component Description

The BKG/DGFI Combination Center performs a combination of session-based results of the IVS Analysis Centers on an operational basis. The strategy for the combination has been adopted from the combination process developed and performed by the IVS Analysis Coordinator (cf. [3], [4]).

At BKG Combination Center (BKG CC) the following tasks are performed:

- Ensuring quality control of the Analysis Center results: checking the format of the results and their suitability for combination, performing identification and reduction of outliers, comparing the Analysis Centers' results with each other, and comparing the results w.r.t. external time series, e.g. from IERS or IGS.
- Providing feedback to the Analysis Centers: quality control results will be available at the BKG IVS Combination Center Web page [8].
- Creating high quality combination products and performing timely archiving and distribution: combination products will be created using the DGFI DOGS software package [7].
- Submitting official IVS combination products to the IERS: the produced official IVS combination products will be submitted to the responsible IERS components as requested by the IERS. This will be supported by the staff of the IERS Central Bureau at BKG.
- Placing final results in IVS Data Centers: final results will be placed in the BKG Data Center. This will be assisted by the staff of the BKG Data Center in Leipzig.

- Generating official IVS input to the ITRF: official IVS input to the ITRF will be created as combined quarterly solutions in SINEX format.

DGFI is in charge of the following Combination Center functions:

- Developing state-of-the-art combination procedures: state-of-the-art combination procedures will be developed mainly at DGFI. This work, as well as the following item, is also related to DGFI's efforts within the IERS WG on the Combination on Observation Level (COL).
- Performing software development and documentation: at DGFI the DOGS software package will be continuously updated by implementing the developed state-of-the-art combination procedures.
- Adhering to IERS Conventions: the DGFI DOGS software package is continuously updated to be in accordance with the IERS Conventions.

### 3. Staff

In the beginning of 2011 Michael Lösler replaced Alexander Lothhammer for the hardware maintenance and for the maintenance of the IVS combination Web pages at BKG. The list of the staff members of the BKG/DGFI Combination Center in 2011 is given in Table 1.

Table 1. Staff members of the BKG/DGFI Combination Center.

Name	Affiliation	Function	E-Mail
Michael Gerstl	DGFI	Software maintenance	gerstl@dgfi.badw.de
Robert Heinkelmann	DGFI	Combination strategies	heinkelmann@dgfi.badw.de
Sabine Bachmann	BKG	Combination	sabine.bachmann@bkg.bund.de
Michael Lösler	BKG	Hardware/Web site maintenance	michael.loesler@bkg.bund.de

### 4. Current Status and Activities

The combination of the IVS Rapid EOP series (R1 and R4 sessions), which started in 2009 at BKG, has been continued routinely in 2011. In 2011, six IVS Analysis Centers (BKG, DGFI, GSFC, IAA, OPA, and USNO) contributed to the IVS combined product (see [4]). Potential new ACs are AUS, CGS, NMA, and TUW. The rapid solutions contain only R1 and R4 sessions, and new data points are added twice a week as soon as the SINEX files of at least four IVS Analysis Centers are available. The results of the combination process are placed in the BKG Data Center in Leipzig. The combined rapid EOP series, as well as the results of the quality control of the Analysis Center results, are also available directly at the BKG/DGFI Combination Center Web page [8] or via the IVS Analysis Coordinator Web site [6]. The inclusion of new Analysis Centers has continued, and new Web-based analysis possibilities of combined products have been made available.

## 5. Plans for 2012

In 2012 the work of the BKG/DGFI Combination Center will focus on the following:

- Including three new Analysis Center solutions: one based on the GEOSAT software and provided by Halfdan Pascal Kierulf from the Geodetic Institute, Norwegian Mapping Authority (NMA), Hønefoss, Norway; another one based on the OCCAM software and provided by Oleg Titov from Geoscience Australia (AUS), Canberra, Australia; and a third one based on VieVS (Vienna VLBI Software) provided by the Vienna VLBI Group from the Technical University of Vienna, Austria.
- Inclusion of source coordinates in the routine combination process as soon as enough Analysis Centers provide source parameters in their SINEX files.
- Extending the Web-based data analysis feature on the IVS Combination Center Web pages ([8]).
- Providing more products and information resulting from the combination process.

## References

- [1] Heinkelmann, R., Böhm J., Bolotin S., Engelhardt G., Haas R., Lanotte R., MacMillan D.S., Negusini M., Skurikhina E., Titov O., Schuh H., VLBI-derived troposphere parameters during CONT08, *J Geod*, SI CONT08, submitted.
- [2] Kutterer, H., Krügel M., Tesmer V., Towards an improved assessment of the quality of terrestrial reference frames, in: Drewes H. (ed.) *Geodetic Reference Frames*, IAG Symposia 143, doi: 10.1007/978-3-642-00860-3\_10, Springer-Verlag Berlin Heidelberg, 2009.
- [3] Nothnagel, A., Böckmann, S., Artz, T., Analysis Coordinator Report, in: International VLBI Service for Geodesy and Astrometry 2007 Annual Report, NASA/TP-2008-214162, D. Behrend and K. D. Baver (eds.), 16–17, 2008.
- [4] Nothnagel, A., Böckmann, S., Artz, T., Analysis Coordinator Report, in: International VLBI Service for Geodesy and Astrometry Annual Report 2009, NASA/TP-2010-215860, D. Behrend and K. D. Baver (eds.), 45–47, 2010.
- [5] Schwegmann, W., Gerstl, M., Heinkelmann, R., BKG/DGFI Combination Center Annual Report 2008, in: International VLBI Service for Geodesy and Astrometry Annual Report 2008, NASA/TP-2009-214183, D. Behrend and K. D. Baver (eds.), 250–252, 2009.
- [6] <http://vlbi.geod.uni-bonn.de/IVS-AC/index.html>  
BKG/DGFI Combination Center results at Analysis Coordinator's Web page.
- [7] [http://ilrs.dgfi.badw.de/fileadmin/dogs/cs\\_manual.ps](http://ilrs.dgfi.badw.de/fileadmin/dogs/cs_manual.ps)  
DOGS\_CS software manual (German version only).
- [8] <http://ida.bkg.bund.de/IVS/>  
BKG Combination Center Web page.

# Matera CGS VLBI Analysis Center

*Roberto Lanotte*

## Abstract

This paper reports the VLBI data analysis activities at the Space Geodesy Center (CGS), Matera, from January 2011 through December 2011 and the contributions that the CGS intends to provide for the future as an IVS Analysis Center.

## 1. General Information

The Matera VLBI station became operational at the Space Geodesy Center (CGS) of the Italian Space Agency (ASI) in May 1990. Since then, it has been active in the framework of the most important international programs. The CGS, operated by e-geos (a Telespazio/ASI company) on behalf of ASI, provides full scientific and operational support using the main space geodetic techniques: VLBI, SLR, and GPS.

## 2. Staff at CGS contributing to the IVS Analysis Center

- Dr. Giuseppe Bianco, responsible for CGS/ASI (primary scientific/technical contact).
- Dr. Rosa Pacione, responsible for scientific activities, e-geos.
- Dr. Roberto Lanotte, geodynamics data analyst, e-geos.

## 3. Current Status and Activities

### 3.1. Global VLBI Solution cgs2010a

The main VLBI data analysis activities at the CGS in the year 2011 were directed towards the realization of a global VLBI solution, named cgs2010a, using the CALC/SOLVE software (developed at GSFC). The solution activities, started at the end of 2010, ended in March 2011, when the solution sections (crf, trf, and eop) were published in the IVS archives. The main, final, characteristics of this solution are:

- Data span:  
1979.08.03 - 2010.12.29 (3924 sessions)
- Estimated Parameters:
  - Celestial Frame:  
Right ascension and declination as global parameters for 839 sources
  - Terrestrial Frame:  
Coordinates and velocities for 81 stations as global parameters
  - Earth Orientation:  
Unconstrained X pole, Y pole, UT1, Xp rate, Yp rate, UT1 rate, dpsl and depl.

### **3.2. IVS Tropospheric Products**

Regular submission of tropospheric parameters (wet and total zenith path delays, and east and north horizontal gradients) for all VLBI stations observing in the IVS R1 and R4 sessions continued during 2011. At present 1056 sessions have been analyzed and submitted, covering the period from 2002 to 2011. The results are available at the IVS products ftp site.

### **3.3. IVS Product “Time Series of Baseline Lengths”**

Regular submission of station coordinate estimates, in SINEX files, continued during 2011 for the IVS product “Time Series of Baseline Lengths”. This is composed of 3693 sessions, from 1979 to 2011.

### **3.4. CGS Contribution to IERS EOP Operational Series**

Since 2008, CGS has been delivering IERS R1 and R4 session EOP estimates as a regular contribution to the IERS EOP operational series. The whole cgs2007a solution, available when the contribution started, has been delivered to IERS as a reference series updated by the periodic EOP solution submission.

## **4. Future Plans**

- Continue and improve the realization of our global VLBI solution, providing its regular update on time.
- Continue to participate in IVS analysis projects, providing the datum-free normal equations.

# DGFI Analysis Center Annual Report 2011

*Robert Heinkelmann, Michael Gerstl, Julian Andres Mora-Diaz, Manuela Seitz*

## Abstract

This report summarizes the activities of the DGFI Analysis Center in 2011 and outlines the planned activities for 2012.

## 1. General Information and Component Description

The German Geodetic Research Institute (Deutsches Geodätisches Forschungsinstitut, DGFI, <http://www.dgfi.badw.de>) is an autonomous and independent research institute hosted at the Bavarian Academy of Sciences (BAdW), Munich. It is run by the Free State of Bavaria. The research covers all fields of geodesy and includes participation in national and international projects as well as functions in international bodies. Since October 2010 the scientific geodetic institutions in Munich and Bavaria — namely the Institute of Astronomical and Physical Geodesy (IAPG) and the Forschungseinrichtung Satellitengeodäsie (FESG) including the personnel at the Geodetic Observatory Wettzell (both at Technical University Munich (TUM)), the Bayerische Kommission für die internationale Erdmessung (BEK) and the Deutsches Geodätisches Forschungsinstitut of the Deutsche Geodätische Kommission (both at the Bavarian Academy of Sciences) — have worked together in a cooperation called Center for Geodetic Earth system research (Centrum für Geodätische Erdsystemforschung, CGE; <http://www.iapg.bv.tum.de/2791632-~iapg~forschung~boards~cge.html>). In 2011 the BEK and the Kommission für Glaziologie together founded the Kommission für Erdmessung und Glaziologie (KEG), while the geodetic part of this commission remains a part of CGE.

## 2. Staff

The DGFI IVS AC (<http://www.dgfi.badw.de/index.php?id=126&L=2>) is operated by Robert Heinkelmann and Manuela Seitz. In addition, Michael Gerstl works on development and numerical optimizations of the VLBI analysis software DOGS-RI (Radio Interferometry). Julian Andres Mora-Diaz (Figure 1) joined our VLBI group in March 2011. With his background (BSc in Physics, MSc in Astronomy), he is most of all interested in AGNs, astrometry, geodetic VLBI, and astrophysics. We are happy to welcome him onboard.



Figure 1. Our new team member: Julian Andres Mora-Diaz.



### 3. Current Status and Activities

- Rearrangement of the VLBI software used and developed at DGFI

The VLBI analysis software used at DGFI is currently rearranged and will be part of the DGFI Orbit and Geodetic Parameter Estimation Software DOGS (Heinkelmann and Gerstl, 2010), named DOGS-RI (Radio Interferometry).

- IVS Operational Analysis Center at DGFI

DGFI routinely processes the standard IVS sessions (currently the two IVS rapid turnaround sessions IVS-R1 and -R4) and additional sessions of the geodetic and astrometric program run by IVS and delivers datum free normal equations in SINEX format. For the operational analysis and for the preparation of normal equations in SINEX format, OCCAM and DOGS-CS are used. The operational processes now completely run on DGFI-owned hardware under the Linux OS.

- Atmosphere research

In 2011 our main scientific work focussed on the atmosphere: we found very good agreement of VLBI VTEC with other space geodetic techniques during CONT08 (Dettmering et al., 2011a) and included VLBI-derived VTEC into a regional multi-level model over the South American continent (Dettmering et al., 2011b). The tropospheric estimates during CONT08 were compared among the techniques (Teke et al., 2011), and some new insights and conclusions could be drawn from intra-technique comparison and combination (Heinkelmann et al., 2011).

### 4. Future Plans

At DGFI IVS AC we want to continue our investigations concerning the atmosphere. The new VLBI analysis software DOGS-RI and DGFI's OCCAM version will be developed in parallel for a while. In 2012 we plan to switch all VLBI analysis to DOGS-RI.

### References

- [1] Dettmering D., R. Heinkelmann, and M. Schmidt: Systematic differences between VTEC obtained by different space-geodetic techniques during CONT08, *J Geod*, DOI 10.1007/s00190-011-0473-z, 2011a
- [2] Dettmering D., M. Schmidt, R. Heinkelmann, and M. Seitz: Combination of different space-geodetic observations for regional ionosphere modeling, *J Geod*, DOI 10.1007/s00190-010-0423-1, 2011b
- [3] Heinkelmann R. & M. Gerstl: OCCAM - LSM for Linux: new developments at DGFI (poster). 6th International VLBI Service for Geodesy and Astrometry General Meeting, 7-13 February 2010, Hobart, Australia, 2010
- [4] Heinkelmann R., J. Böhm, S. Bolotin, G. Engelhardt, R. Haas, R. Lanotte, D. S. MacMillan, M. Negusini, E. Skurikhina, O. Titov, and H. Schuh: VLBI-derived troposphere parameters during CONT08, *J Geod*, DOI 10.1007/s00190-011-0459-x, 2011
- [5] Teke K., J. Böhm, T. Nilsson, H. Schuh, P. Steigenberger, R. Dach, R. Heinkelmann, P. Willis, R. Haas, S. García-Espada, T. Hobiger, R. Ichikawa, and S. Shimizu: Multi-technique comparison of troposphere zenith delays and gradients during CONT08, *J Geod*, DOI 10.1007/s00190-010-0434-y, 2011

## FFI Analysis Center

*Per Helge Andersen*

### Abstract

This report discusses the current status of the FFI Associate Analysis Center as well as upcoming changes.

### 1. Status and Future Changes

The Norwegian Mapping Authority (NMA) and FFI have for the last few years had a close cooperation in the analysis of space geodetic data using the GEOSAT software. NMA has recently been given the status of an Associate Analysis Center of IVS (28 October 2010). The plan is that FFI will end this formal role in 2012. The future GEOSAT activities at both institutions will be coordinated by NMA.

All VLBI analysis activities in 2011 have been performed within NMA where Dr. Per Helge Andersen has been an external contributor paid by NMA. Therefore, the reader should consult the NMA AAC report for further information.

### 2. Staff

Dr. Per Helge Andersen - Research Professor of Forsvarets forskningsinstitutt (FFI and NMA).  
Dr. Halfdan Pascal Kierulf - Research geodesist of the Norwegian Mapping Authority (NMA).

## The BKG/IGGB VLBI Analysis Center

*Volkmar Thorandt, Axel Nothnagel, Gerald Engelhardt, Dieter Ullrich, Thomas Artz,  
Judith Leek, Christoph Holst*

### Abstract

In 2011, the activities of the BKG/IGGB VLBI Analysis Center, as in previous years, consisted of routine computations of Earth orientation parameter (EOP) time series and of a number of research topics in geodetic VLBI. The VLBI group at BKG continued its regular submissions of time series of tropospheric parameters and the generation of daily SINEX (Solution INdependent EXchange format) files. Quarterly updated solutions have been computed to produce terrestrial reference frame (TRF) and celestial reference frame (CRF) realizations. Routine computations of the UT1–UTC Intensive observations include all sessions of the Kokee–Wettzell and Tsukuba–Wettzell baselines and the networks Kokee–Svetloe–Wettzell and Ny-Ålesund–Tsukuba–Wettzell. After a big earthquake on March 11th, 2011 near the Tsukuba station, no IVS products including Tsukuba Intensive observations could be delivered. At IGGB, the emphasis has been placed on individual research topics.

### 1. General Information

The BKG/IGGB VLBI Analysis Center has been established jointly by the analysis groups of the Federal Agency for Cartography and Geodesy (BKG), Leipzig, and the Institute of Geodesy and Geoinformation of the University of Bonn (IGGB). Both institutions cooperate intensely in the field of geodetic VLBI. The responsibilities include both data analysis for generating IVS products and special investigations with the goal of increasing accuracy and reliability. BKG is responsible for the computation of time series of EOP and tropospheric parameters, for the generation of SINEX files for 24-hour VLBI sessions and 1-hour Intensive sessions, and for the generation of quarterly updated global solutions for TRF and CRF realizations. Besides data analysis, the BKG group is also responsible for writing schedules for the Tsukuba–Wettzell INT2 UT1–UTC observing sessions. In addition to this, schedules for observing the Kokee–Wettzell baseline on weekends were made after the Japan earthquake in March 2011. IGGB continues to host the office of the IVS Analysis Coordinator and carries out special investigations within the technique of geodetic and astrometric VLBI. Details of the research topics of IGGB are listed in Section 3.

### 2. Data Analysis at BKG

At BKG, the Mark 5 VLBI data analysis software system Calc/Solve, release 2010.05.21 [3], has been used for VLBI data processing. It is running on a Linux operating system. As in the previous releases, the Vienna Mapping Function (VMF1) has been implemented in a separate Solve version. This modified version was used for all data analysis. The VMF1 data were downloaded daily from the server of the Vienna University of Technology. Additionally, the technological software environment for Calc/Solve has been refined to link the Data Center management with the pre- and post-interactive parts of the EOP series production and to monitor all Analysis and Data Center activities.

- **Processing of correlator output**

The BKG group continued the generation of calibrated databases for the sessions correlated at

the MPIfR/BKG Astro/Geo Correlator at Bonn (e.g., EURO, OHIG, and T2) and submitted them to the IVS Data Centers.

- **Scheduling**

BKG continued scheduling the INT2 Intensive sessions, which are observed on the TSUKUBA-WETTZELL baseline. Due to the earthquake in Japan on March 11th, 2011, scheduling at BKG was extended for the INT1 Intensive sessions on the KOKEE-WETTZELL baseline on weekends. Altogether 153 schedule files were created in 2011.

- **BKG EOP time series**

The BKG EOP time series bkg00013 was continued. The main features of this solution were not changed. Nevertheless, slight changes in modeling of the TSUKUB32 station from globally estimated station coordinates to locally estimated coordinates in all respective sessions were made. Furthermore three new VLBI stations in the southern hemisphere could be included successfully in data processing.

Each time after the preprocessing of any new VLBI session (correlator output database version 1), a new global solution with 24-hour sessions since 1984 was computed, and the EOP time series bkg00013 was extracted including the coordinates of those stations for which components were estimated for each session. Altogether 4246 sessions were processed. The main parameter types in this solution are globally estimated station coordinates and velocities together with radio source positions. The datum definition was realized by applying no-net-rotation and no-net-translation conditions for 26 selected station positions and velocities with respect to VTRF2008a and a no-net-rotation condition for 295 defining sources with respect to ICRF2. The station coordinates of the telescopes AIRA (Japan), CHICHI10 (Japan), CTVASTJ (Canada), DSS13 (USA), HOBART12 (Australia), PT\_REYES (USA), SEST (Chile), SINTOTU3 (Japan), TIGOCONC (Chile), TSUKUB32 (Japan), WIDE85\_3 (USA), VERAISGK (Japan), VERAMZSW (Japan), and YEBES40M (Spain) were estimated as local parameters in each session. The three new VLBI stations KATH12M (Australia), WARK12M (New Zealand), and YARRA12M (Australia) were modeled in the same way.

Regular analysis of the UT1-UTC Intensive time series bkgint09 was continued. Reporting was extended to also list the a priori UT1-UTC values as well as the stations participating in each session. The series bkgint09 was generated with fixed TRF (VTRF2008a) and fixed ICRF2. The a priori EOP were taken from finals USNO series [7]. The estimated parameter types were only UT1-TAI, station clock, and zenith troposphere. Observations of the two baselines KOKEE-WETTZELL and TSUKUBA-WETTZELL and also of the networks KOKEE-SVETLOE-WETTZELL and NYALES20-TSUKUBA-WETTZELL were processed regularly. But no time series of Intensive sessions with station TSUKUBA were delivered to IVS after the Japan earthquake. The analysis of the INT3 sessions processed at the Bonn correlator every Monday after transferring the raw observations by e-transfer could be finished almost always on the same day. Maximal delays of one day appeared because of problems in data transfer. A total of 3803 UT1 Intensive sessions were analyzed for the period from 1999.01.01 to 2011.12.31.

- **Quarterly updated solutions for submission to IVS**

In 2011, one quarterly updated solution was computed for the IVS products TRF and CRF. There are no differences in the solution strategy compared to the continuously computed EOP time series bkg00013. The results of the radio source positions were submitted to

IVS in IERS format. The TRF solution is available in SINEX format, version 2.1, and includes station coordinates, station velocities, and radio source coordinates together with the covariance matrix, information about constraints, and the decomposed normal matrix and vector.

- **Tropospheric parameters**

The VLBI group of BKG continued regular submissions of long time series of tropospheric parameters to the IVS (wet and total zenith delays and horizontal gradients) for all VLBI sessions since 1984. The tropospheric parameters were extracted from the standard global solution bkg00013 and transformed into SINEX format.

- **Daily SINEX files**

The VLBI group of BKG also continued regular submissions of daily SINEX files for all available 24-hour sessions for the IVS combined products and for the IVS time series of baseline lengths. In addition to the global solutions, independent session solutions were computed for the station coordinates, radio source coordinates, and EOP parameters including the X,Y-nutation parameters. The a priori datum for TRF is defined by the VTRF2008a, and ICRF2 is used for the a priori CRF information.

- **SINEX files for Intensive sessions**

The parameter types are station coordinates, pole coordinates and their rates, and UT1-TAI and its rate. But only the normal equations stored in the SINEX files are important for further intra-technique combination or combination with other space geodetic techniques.

### 3. Research Topics at IGGB

- **Determination of sub-daily tidal ERP models**

To overcome deficiencies of the official IERS model for tidal Earth Rotation Parameter (ERP) variations with periods around one day and below [5], empirical models estimated from space geodetic techniques might be used. At IGGB, a method based on transformations of normal equation systems has been developed to estimate such a model [2]. This method has also been successfully applied to estimate combined sub-daily ERPs from GPS and VLBI observations [1]. Within this combination no constraints on the ERPs are necessary as geometric instabilities of the techniques are cross-wise compensated. The final combined model as published in [1] was distributed to the different services to be validated.

- **Automatic scheduling based on Singular Value Decomposition**

An automatic scheduling process for VLBI Intensive sessions based on singular value decomposition has been developed [6]. Based on a simple starting configuration, the observations are selected successively by analyzing the Jacobian matrix. Indicators on the geometry of the measurement derived from the singular value decomposition are used for the selection of the sources to be observed with the purpose of improving the dUT1 determination. The formal errors of dUT1 deduced from the normal equation serve as an assessment criterion of the scheduling method. The new scheduling method shows promise for improvements of the dUT1 determination by IVS Intensive observing sessions.

- **Gravitational deformation of the Effelsberg radio telescope**

Due to gravitation, the main reflector of a radio telescope undergoes a deformation, which

causes a change in focal length depending on the elevation angle of the telescope. In order to estimate these focal length variations of the 100-m radio telescope at Effelsberg, Germany, the main reflector was scanned at seven different elevation angles by a laser scanner mounted near the primary focus. A three-step adjustment procedure based on an alteration of the orthogonal distance regression and several outlier eliminations is then used to determine the variations of the elevation-dependent focal lengths [4]. The estimated focal length decreases by a maximum of 12.6 mm when tilting the reflector from  $90^\circ$  to  $7.5^\circ$  elevation angle. The post-fit discrepancies between the best-fit paraboloid and the reflector's surface are Gaussian distributed within the accuracy of the measurements, which supports the assumption of a homologous deformation of the main reflector.

#### 4. Personnel

Table 1. Personnel at BKG/IGGB Analysis Center

Thomas Artz	IGGB	+49-228-733563	thomas.artz@uni-bonn.de
Gerald Engelhardt	BKG	+49-341-5634438	gerald.engelhardt@bkg.bund.de
Christoph Holst	IGGB	+49-228-733570	holst@igg.uni-bonn.de
Axel Nothnagel	IGGB	+49-228-733574	nothnagel@uni-bonn.de
Judith Leek	IGGB	+49-228-733565	judith.leek@igg.uni-bonn.de
Volkmar Thorandt	BKG	+49-341-5634285	volkmar.thorandt@bkg.bund.de
Dieter Ullrich	BKG	+49-341-5634328	dieter.ullrich@bkg.bund.de
Reiner Wojdziak	BKG	+49-341-5634286	reiner.wojdziaak@bkg.bund.de

#### References

- [1] T. Artz, L. Bernhard, A. Nothnagel, P. Steigenberger, and S. Tesmer. Methodology for the combination of sub-daily Earth rotation from GPS and VLBI observations. *J Geod*, 86(3):565–585, 2012.
- [2] T. Artz, S. Tesmer, and A. Nothnagel. Assessment of Periodic Sub-diurnal Earth Orientation Parameter Variations at Tidal Frequencies via Transformation of VLBI Normal Equation Systems. *J Geod*, 85(9):221–239, 2011.
- [3] GSFC, NASA (2010): Release of Mark 5 VLBI Analysis Software Calc/Solve from May 21, 2010 (Web reference: <http://gemini.gsfc.nasa.gov/solve>).
- [4] C. Holst, P. Zeimet, A. Nothnagel, W. Schauerte, and H. Kuhlmann. Estimation of Focal Length Variations of a 100 m Radio Telescope's Main Reflector by Laser Scanner Measurements. *Journal of Surveying Engineering*, 2012 (accepted)
- [5] G. Petit and B. Luzum. IERS Conventions 2010. IERS Technical Note 35, Verlag des Bundesamtes für Kartographie und Geodäsie, Frankfurt am Main, July 2010. ISSN: 1019-4568, in print (available electronically at <http://www.iers.org/IERS/EN/Publications/TechnicalNotes/tn36.html>).
- [6] J. Pietzner and A. Nothnagel. Geodetic VLBI Intensive Scheduling based on Singular Value Decomposition. In W. Alef, S. Bernhart, and A. Nothnagel (eds), *Proceedings of the 20th European VLBI for Geodesy and Astrometry Working Meeting*, pages 9–13. Schriftenreihe des Instituts für Geodäsie und Geoinformation der Rheinischen-Friedrich-Wilhelms Universität Bonn, No. 22
- [7] USNO (2011): Earth orientation parameters series from finals USNO series 2011, (Web reference: [http://gemini.gsfc.nasa.gov/500/oper/solve\\_apriori\\_files/usno\\_finals.erp](http://gemini.gsfc.nasa.gov/500/oper/solve_apriori_files/usno_finals.erp)).

## GSFC VLBI Analysis Center

*David Gordon, Chopo Ma, Dan MacMillan, John Gipson, Karen Baver, Sergei Bolotin,  
Karine Le Bail, Johanna Juhl, David Eriksson*

### Abstract

This report presents the activities of the GSFC VLBI Analysis Center during 2011. The GSFC VLBI Analysis Center analyzes all IVS sessions, makes regular IVS submissions of data and analysis products, and performs research and software development aimed at improving the VLBI technique.

## 1. Introduction

The GSFC VLBI Analysis Center is located at NASA's Goddard Space Flight Center in Greenbelt, Maryland. It is part of a larger VLBI group which also includes the IVS Coordinating Center, the CORE Operation Center, a Technology Development Center, and a Network Station. The Analysis Center participates in all phases of geodetic and astrometric VLBI analysis, software development, and research. We maintain a Web site at <http://lupus.gsfc.nasa.gov>. We also provide a pressure loading service to the geodetic community at <http://gemini.gsfc.nasa.gov/results/aplo>.

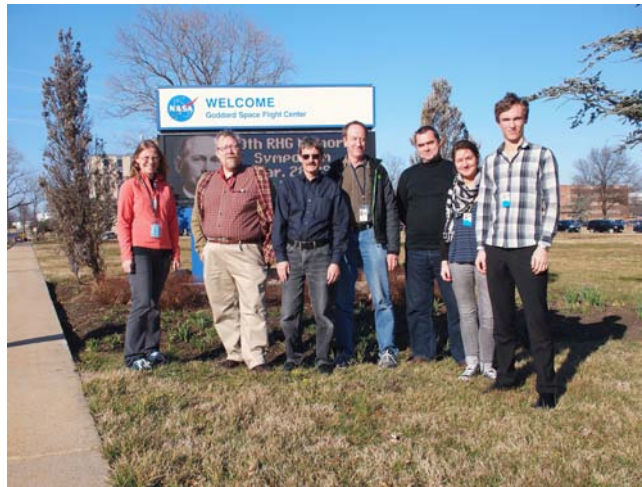

Figure 1. Members of the GSFC VLBI Analysis Center.

## 2. Activities

### 2.1. Analysis Activities

The GSFC VLBI Analysis Center analyzes all IVS sessions, using the *Calc/Solve* system, and performs the fringe fitting and *Calc/Solve* analysis of the VLBA-correlated RDV sessions. The group submits the analyzed databases to IVS for all R1, RDV, R&D, APSG, CONT11, INT01, and INT03 sessions. During 2011, GSFC analyzed 153 24-hour (52 R1, 49 R4, 5 CONT11, 6 RDV, 5 R&D, 6 EURO, 7 T2, 3 APSG, 3 OHIG, 3 CRF, 3 CRDS, 1 AUST, 4 JADE, and 6 JAXA) sessions, and 406 1-hour UT1 (280 INT01, 88 INT02, and 38 INT03) sessions, and we submitted

updated EOP and daily Sinex files to IVS immediately following analysis. Two updates were made in 2011 of our 24-hr and Intensive EOP series. Also, as part of the RDV program, we observed 24 requested sources for the astronomical community.

## 2.2. Research Activities

- **Intensive Scheduling:** We continued studying the alternative INT01 scheduling strategy that we proposed in 2009 and tested in several 2009 and 2010 R&D sessions. This strategy consists of using all mutually visible geodetic sources, and it is now called the Uniform Sky Strategy (USS). It was used in INT01 sessions on alternating days continuously since Dec. 2010. An analysis of the first five months showed that while it improves the sky coverage, it also yields higher UT1 formal errors and session fits, indicating a need for further analysis. With the first full year of continuous data now available, we will begin this analysis in early 2012.
- ***Fourfit* Processing of RDV Sessions:** A transition from *AIPS* post-correlation processing of RDV sessions to *Fourfit* processing was begun. An RDV session was *fourfit* processed at both Haystack and USNO and was compared to an *AIPS* version. The *fourfit* processing was shown to result in greater sensitivity, better detection of weak sources, and fewer subambiguity errors. All new RDVs will now be *fourfit* processed at GSFC.
- **Meteorological Data Analysis:** The geodetic VLBI data set is known to have many cases of missing, biased, and inaccurate meteorological data that impacts the quality of the VLBI processing. We developed statistical tools to detect bad and missing met data, and we compared the met data to other sources. To homogenize the met data, we used pressure and temperature time series derived from the ECMWF model, interpolated and extrapolated to the VLBI stations. For this purpose, we modified *Solve* to allow use of an external meteorological time series. Use of our ECMWF derived time series instead of the database met values showed noticeable improvements in the solutions. We also implemented an option that uses a time lag in the thermal deformation model that can be chosen by the user.
- **Analysis of LOD Time Series with the SSA:** We studied the length-of-day time series derived from the GSFC 2011a solution with the Singular Spectrum Analysis (SSA) tool. This allowed us to extract different significant components and to compare them with the Multivariate ENSO Index (MEI). We first studied the time series with the long-term tendency removed. The time-varying amplitudes of the annual and semi-annual components, as well as a secondary tendency extracted by the SSA, show a very strong correlation with the MEI time series. In a second study, we removed the long-term tendency, and annual and semi-annual signals at constant amplitude with time. A correlation study of the principal component of the remaining signal of the LOD with the MEI showed that they correlate strongly with each other for a time delay of 31 days, which is in agreement with other studies.
- **Source Monitoring:** Together with USNO we continued our program of monitoring all ICRF2 defining sources. Our goal is to observe geodetic sources at least 12 times and non-geodetic sources at least 3 times during a 12 month period. The R1, R4, and RDV sessions participate in the monitoring program.
- **VLBI2010 Systematic Errors:** We investigated the level of error of VLBI2010 geodetic measurements by simulating the effect of tropospheric turbulence, clock error, observation noise, hydrostatic troposphere mapping function error, antenna gravitational deformation, and site



pressure error. Biases at the 1-2 mm level in vertical site position estimates can be caused by troposphere mapping function error, gravitational antenna deformation, or site pressure errors. Errors due to tropospheric turbulence decrease with latitude, leading to 1-3 mm RMS site vertical error but no significant bias. Given the precision and stability of high quality meteorological sensors, vertical bias errors due to pressure (used to compute hydrostatic delay) and temperature (used to compute antenna thermal deformation) errors should be much less than 1 mm.

- **Tsukuba Postseismic Motion:** The observed motion of the TSUKUB32 antenna after the Tohoku earthquake was nonlinear following a coseismic displacement of about 700 mm, primarily in the eastward direction. Six months after the earthquake, the eastward displacement rate was about 15 cm/yr greater than the long term rate before the earthquake. Analysis of the single baseline Tsukuba-Wettzell Intensive sessions requires very accurate site positions since they cannot be estimated along with UT1. We used GPS post-earthquake positions from the co-located GPS antenna TSKB to correct the TSUKUB32 positions after the earthquake. After correction, the Tsukuba-Wettzell and Kokee-Wettzell UT1 estimates agree with the USNO UT1 combination solution with the same level of WRMS and bias error.
- **Hydrology Loading:** Continental hydrology loading causes peak-to-peak vertical site displacements of 3-8 mm that are strongly seasonal. We have computed the hydrological loading using both the GSFC GLDAS hydrology model data and GRACE data. Applying either loading series in *Calc/Solve* analysis reduces the UEN site position and baseline length scatter. We are working on starting a hydrology loading service to provide site loading series to the VLBI user community.
- **Astronomical Source Catalog and Source Time Series:** A new astronomical source catalog, *gsf2011a\_astro*, was generated. This catalog contains positions of 3671 total sources, of which 3522 are X/S sources, 123 are X/GPS-ionosphere sources, and 26 are X-only sources. A new source time series, *gsf2011a\_ts*, was also generated. It contains single session positions of 1366 sources in the ICRF2 time series format. Both files will be updated regularly and are available at [http://lupus.gsfc.nasa.gov/dataresults\\_main.htm](http://lupus.gsfc.nasa.gov/dataresults_main.htm).

### 2.3. Software Development

The GSFC VLBI Analysis Center develops and maintains the *Calc/Solve* analysis system, a package of approximately 120 programs and 1.2 million lines of code. A new version of *Calc/Solve* was released in April 2011.

Also, we continued refining the new data structure which stores VLBI data in netCDF files organized by an ASCII ‘wrapper’ file. We wrote software to convert from the Mark III database format into this new format. The software converts around 80% of the data included in a database, including all of the data currently contained in NGS cards. We are in the process of modifying *Calc/Solve* to use this new format and successfully ran a large global solution, producing results essentially identical to the standard processing.

We also continued work on a new software system. A replacement for the interactive part of *Solve*, *νSolve*, is being developed using C++. *νSolve* is currently able to read in a pair of X/S databases, resolve ambiguities, deal with clock breaks, evaluate ionospheric corrections, and edit outliers. It performs analysis of VLBI sessions using the Square Root Information Filter

and can treat estimated parameters as local (one value for a session), arc (multiple values for a session), piece-wise linear, and stochastic. It can write out a processed session in Mark III database format and can work either in a standalone mode or interacting with the Mark III catalog system. Currently we are making comparisons of  $\nu$ *Solve* and *Solve* analysis. We expect to make the first public release of this software in early 2012.

### 3. Staff

The Analysis Center staff consists of one GSFC civil servant, Dr. Chopo Ma, six NVI Inc. employees who work under contract to GSFC, and two student interns from Chalmers University of Technology. Dr. Ma oversees the GSFC VLBI project for GSFC and is also the IVS co-representative to the IERS and the current chair of the IERS Directing Board. Dr. John Gipson is the GSFC VLBI Project Manager and also the chair of IVS Working Group 4 on VLBI Data Structures. Table 1 lists the staff members and their main areas of activity.

Table 1. Staff members and their main areas of activity.

Ms. Karen Baver	Intensive analysis, monitoring, and improvement; software development; Web site development; quarterly nuvel updates.
Dr. Sergei Bolotin	Database analysis, $\nu$ <i>Solve</i> development.
Dr. John Gipson	Source monitoring, high frequency EOP, parameter estimation, new data structure, station dependent noise.
Dr. David Gordon	Database analysis, RDV analysis, ICRF2 and astronomical catalogs, K/Q reference frame, <i>Calc</i> development, quarterly ITRF updates.
Dr. Karine Le Bail	Time series statistical analysis (EOP, nutation, source positions), database meteorological data analysis.
Dr. Chopo Ma	ICRF2, CRF/TRF/EOP, K/Q reference frame.
Dr. Daniel MacMillan	CRF/TRF/EOP, mass loading, antenna deformation, apparent proper motion, VLBI2010 simulations, VLBI/SLR/GPS combinations.
Ms. Johanna Juhl	Meteorological data analysis, ray tracing.
Mr. David Eriksson	Hydrology loading, topographic errors in pressure loading.

### 4. Future Plans

Plans for the next year include: ICRF2 maintenance, astronomical catalog expansion, participation in VLBI2010 development, continued development of the new VLBI data structure and the new analysis software, upgrade of program *Calc*, creation of a hydrology loading service, creation of a pressure and temperature service using ECMWF data, and further research aimed at improving the VLBI technique.

# IAA VLBI Analysis Center Report 2011

*Elena Skurikhina, Sergey Kurdubov, Vadim Gubanov*

## Abstract

This report presents an overview of IAA VLBI Analysis Center activities during 2011 and the plans for the coming year.

## 1. General Information

The IAA IVS Analysis Center (IAA AC) is located at the Institute of Applied Astronomy of the Russian Academy of Sciences in St. Petersburg, Russia. The IAA AC contributes to IVS products, such as daily SINEX files, TRF, CRF, rapid and long-term series of EOP, baseline lengths, and tropospheric parameters. EOP, UT1, and station positions were estimated from domestic observation programs Ru-E and Ru-U. The IAA AC generates NGS files.

## 2. Component Description

The IAA AC performs data processing of all kinds of VLBI observation sessions. For VLBI data analysis we use the QUASAR and the OCCAM/GROSS software packages. All reductions are performed in agreement with IERS Conventions (2010). Both packages use NGS files as input data.

The IAA AC submits to the IVS Data Center all kinds of products: daily SINEX files for EOP and EOP-rates and station position estimates, TRF, CRF, baseline length, and tropospheric parameters.

The QUASAR and the OCCAM/GROSS software packages are supported and developed. IVS NGS files are generated in automatic mode on a regular basis.

## 3. Staff

- Vadim Gubanov, Prof.: development of the QUASAR software and development of the methods of stochastic parameter estimation.
- Sergey Kurdubov, Dr.: scientific researcher: development of the QUASAR software, global solution, and DSNX file calculation.
- Elena Skurikhina, Dr.: team coordinator, VLBI data processing, and OCCAM/GROSS software development.

## 4. Current Status and Activities

### • Software Development for VLBI Processing

The QUASAR software is capable of calculating all types of IVS products. A new release of the QUASAR software was developed in 2011 by S. Kurdubov with the ability to estimate a generous amount of new parameters (tidal waves, for example).

### • Routine Analysis

During 2011 the IAA AC continued to submit daily SINEX files for the IVS-R1 and IVS-R4 sessions as rapid solution (iaa2010a.snx) and SINEX files based on all 24-hour experiments for the quarterly solution.

A new global solution was calculated.

The routine data processing was performed with the OCCAM/GROSS software using a Kalman Filter. The IAA AC operationally processed the “24h” and Intensive VLBI sessions and submitted the results to the IERS and IVS on a regular basis. Processing of the Intensive sessions is fully automated. The EOP series iaa2007a.eops and iaa2005a.eopi, baseline lengths iaa2007a.bl, and troposphere parameters iaa2007a.trl were continued. Long-time series of station coordinates, baseline lengths, and tropospheric parameters (ZTD, gradients) were computed with the station position catalog ITRF2005.

- **EOP Parameter Calculation from Domestic QUASAR Network Observations**

Regular determinations of Earth orientation parameters with the QUASAR VLBI Network Svetloe-Zelenchukskaya-Badary and single baseline 1-hour observations for UT1 with e-VLBI transfer were performed weekly. Correlation is performed at the IAA correlator ARC. For 2011 the mean RMS EOP deviations from the IERS 08 C04 series in the Ru-E program were 1.0 mas for Pole position, 35  $\mu$ s for UT1-UTC, and 0.37 mas for Celestial Pole position for 38 Ru-E sessions. The RMS deviation of the Universal Time values from the IERS C04 series for 58 sessions of the Ru-U program was 53  $\mu$ s. We used station positions from the QUASAR global solution in our calculations.

- **Tidal Deformation of the Earth from VLBI Data Analysis**

In a study by V. S. Gubanov and S. L. Kurdubov, statistically significant corrections to the parameters of the lunar-solar tides as the complex Love/Shida numbers were obtained from the analysis of VLBI observations carried out in 1985 – 2010 by international geodetic programs on global networks. The new nominal (independent of frequency) values of these parameters (in  $10^{-4}$ ) are the following:

- for total tide  $h^{(0)} = (6113 \pm 3) - (33 \pm 2)i$ ,  $l^{(0)} = (843 \pm 1) - (5 \pm 2)i$ ,
- for diurnal tides  $h^{(0)} = (6106 \pm 3) - (10 \pm 6)i$ ,  $l^{(0)} = (843 \pm 1) - (8 \pm 1)i$ ,
- for semi-diurnal tides  $h^{(0)} = (6106 \pm 3) - (24 \pm 3)i$ ,  $l^{(0)} = (843 \pm 1) + (3 \pm 1)i$ .

The frequency-dependent effects of resonances in the diurnal tides could not be evaluated because of the existence of close frequencies in their harmonic expansion. In the future, for this purpose it is proposed to involve positional data GPS-measurements. But for 50 VLBI stations we have discovered a new effect of the asymmetry of the horizontal tidal displacement in the direction of tectonic movements of these stations.

- **TSUKUBA station position**

TSUKUB32 station positions and velocities were estimated. After the Tohoku Earthquake we estimated the station position and velocity using a linear approach for two time steps; results are presented in Table 1.

Table 1. Station positions and velocities for TSUKUB32, epoch 2000.0, in ITRF2005.

Time span (MJD)	Station Position, m			Velocity, mm/year		
	X	Y	Z	$V_x$	$V_y$	$V_z$
until 55631	-3957408.757 $\pm 0.001$	3310229.3920 $\pm 0.001$	3737494.782 $\pm 0.002$	-0.0022 $\pm 0.0002$	0.0049 $\pm 0.0001$	-.0053 $\pm 0.0002$
55632 to 55767	-3957405.798 $\pm 0.327$	3310231.506 $\pm 0.292$	3737495.661 $\pm 0.397$	-0.2987 $\pm 0.0287$	-0.2332 $\pm 0.0256$	-0.0861 $\pm 0.0348$
55768 to present	-3957408.0631 $\pm 0.117$	33310229.231 $\pm 0.101$	3737494.3503 $\pm 0.121$	-0.1020 $\pm 0.0099$	-0.0363 $\pm 0.0085$	0.0266 $\pm 0.0102$

## 5. Future Plans

- We plan to continue to submit all types of IVS product contributions.
- Continue investigations of VLBI estimation of EOP, station coordinates, and troposphere parameters, and comparison with satellite techniques.
- Further improve algorithms and software for processing VLBI observations.

## References

- [1] A. Finkelstein, E. Skurikhina, I. Surkis, A. Ipatov, I. Rahimov, S. Smolentsev, “QUASAR National Programs of EOP Determinations”, Measuring the future, Proceedings of the Fifth IVS General Meeting, ed. A. Finkelstein, D. Behrend, St-Petersburg, “Nauka”, 2008, p. 319–323.
- [2] A. Finkelstein, A. Salnikov, A. Ipatov, S. Smolentsev, I. Surkis, I. Gayazov, I. Rahimov, A. Dyakov, R. Sergeev, E. Skurikhina, S. Kurdubov, EOP determination from observations of Russian VLBI-network QUASAR, in Proceedings of the 20th Meeting of the European VLBI Group for Geodesy and Astronomy, Ed. by W. Alef, S. Bernhart, A. Nothnagel, 2011, IGG, Germany, p. 49–51.

## Vienna IGG Special Analysis Center Annual Report 2011

*Harald Schuh, Johannes Böhm, Sigrid Böhm, Matthias Madzak, Vahab Nafisi, Tobias Nilsson, Andrea Pany, Lucia Plank, Benedikt Soja, Hana Spicakova, Jing Sun, Claudia Tierno Ros*

### Abstract

The main activities of the VLBI group at the Institute of Geodesy and Geophysics (IGG) of the Vienna University of Technology in 2011 were related to the development of the Vienna VLBI Software VieVS (<http://vievs.hg.tuwien.ac.at/>). The number of external VieVS users further increased to about twenty, and some of them took part in the second VieVS User Workshop which was held at our institute in September 2011. In the last year, the tools for the VLBI global solutions were further refined and extended, and investigations on scheduling as well as on spacecraft and satellite tracking have been intensified. Furthermore, studies on VLBI2010 simulations, Earth rotation, and geodynamical parameters from VLBI have been continued.

### 1. General Information

The Institute of Geodesy and Geophysics (IGG) is part of the Faculty of Mathematics and Geoinformation of the Vienna University of Technology. It is divided into three research units, one of them focusing on advanced geodesy (mathematical and physical geodesy, space geodesy). Within this research unit, one group (out of three) is dealing with geodetic VLBI.



Figure 1. Members of the VLBI group participating in the EVGA meeting in Bonn: Hana Spicakova, Tobias Nilsson, Harald Schuh, Johannes Böhm, Lucia Plank, Jing Sun, and Claudia Tierno Ros in front of the radio telescope in Effelsberg.

## 2. Staff

Personnel at IGG associated with the IVS Special Analysis Center in Vienna are Harald Schuh (Head of IGG, Chair of the IVS Directing Board), and eleven scientific staff members. Their main research fields are summarized in Table 1.

Table 1. Staff members ordered by their main focus of research.

Johannes Böhm	VLBI2010, atmospheric effects
Jing Sun	VLBI2010, scheduling of VLBI observations
Tobias Nilsson	VLBI2010, turbulence, Earth orientation
Andrea Pany (until 07/2011)	VLBI2010, simulation
Sigrid Böhm	Earth orientation, tidal influences
Lucia Plank	Spacecraft and satellite tracking with VLBI
Benedikt Soja	Relativistic effects of solar system bodies
Matthias Madzak	Ray-tracing, VieVS graphical user interfaces
Hana Spicakova	Global solution, geodynamical parameters
Vahab Nafisi (until 09/2011)	Ray-traced delays for VLBI
Claudia Tierno Ros	External ionospheric delays

## 3. Current Status and Activities

- **Vienna VLBI Software VieVS**

Most of the activities were related to the development of the Vienna VLBI Software (VieVS, <http://vievs.hg.tuwien.ac.at/>). For example, tools for the VLBI global solutions were updated in the latest release (Version 1d), and investigations into spacecraft and satellite tracking have been continued. Furthermore, studies on VLBI2010 simulations, scheduling, Earth rotation, and geodynamical parameters from VLBI were carried out, and the second VieVS User Workshop was held in September 2011.

- **Complex demodulation**

By applying the so-called complex demodulation, high-frequency variations in a time series can be shifted to low frequencies, preserving thereby the original amplitudes. This enables the estimation of diurnal and subdiurnal variations with merely diurnal parameter sampling. The features of the complex demodulation were used in an extended parameterization of polar motion and universal time which was implemented in a dedicated version of VieVS. The functionality of the approach was evaluated by comparing amplitudes and phases of harmonic variations at tidal periods (diurnal/semidiurnal) as derived from demodulated Earth rotation parameters (ERP) to the terms of the conventional model for ocean tidal effects in Earth rotation (see Böhm et al., 2012 [1]).

- **External ionospheric delays in VieVS**

A new module that allows the use of external ionospheric delay corrections calculated from Global Navigation Satellite Systems (GNSS) maps of Total Electron Content (TEC) has been implemented in VieVS. It has been shown that the use of GNSS TEC maps is certainly useful

in the case of single-frequency VLBI observations or when lacking ionospheric information due to measurement errors.

- **Global solutions with VieVS**

VieVS allows a global adjustment of normal equations from single sessions in a separate module called *vie\_glob*. It allows the estimation of terrestrial reference frames (station positions and velocities assuming linear motion of stations), celestial reference frames (source positions) and Earth orientation parameters. We analyzed all 24-hour IVS sessions from 1984.0 to 2011.0 and estimated our new terrestrial and celestial reference frames (VieTRF10a and VieCRF10a; see Spicakova et al. (2012, [4])). Furthermore, we examined the effect of tropospheric delay modeling on the estimated reference frames (see Figure 2).

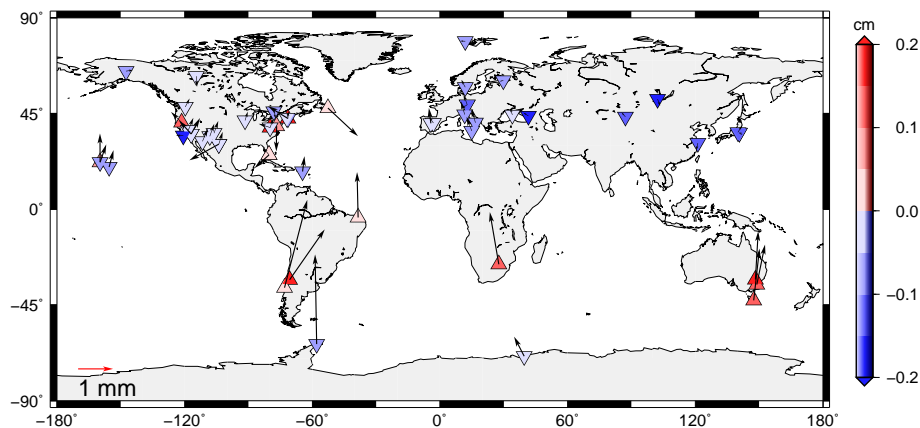

Figure 2. Influence of a priori gradients on station coordinates at epoch 2000.0. In both cases, tropospheric gradients were estimated as piecewise linear offsets every six hours with 1 mm absolute and 0.5 mm relative constraints. We show the differences in the sense *DAO a priori gradients* minus *zero a priori gradients*. Horizontal position changes are shown as arrows, vertical changes by color-coded triangles pointing in the direction of change (from Spicakova et al. (2012, [4])).

- **VLBI for space applications**

The efforts of implementing the processing of VLBI observations of artificial sources within the solar system into VieVS have been continued. Same-beam differential VLBI observations of the Japanese lunar mission SELENE were analyzed with VieVS, and the results were successfully verified by comparison with those obtained by the National Astronomical Observatory (NAOJ), Mizusawa. Additionally, investigations regarding atmospheric effects, as well as the estimation of spacecraft coordinates, were performed. More recently the focus was put on VLBI tracking of satellites orbiting the Earth. This covers delay solutions of GNSS satellites in single mode, GNSS satellites in differential mode with a close-by quasar, and studies of simulated GNSS observations with a four station network.

- **General relativistic delay in VLBI observations**

In terms of the accuracy requirements for the VLBI delay model nowadays and for VLBI2010, the significance of the relativistic effect due to the major celestial bodies was investigated. Therefore, the gravitational time delay for the Earth, the Sun, the Moon, and the planets was calculated for the observational configurations of all R1 and R4 sessions from 2002-2010.



According to our results, besides the Sun and the Earth, we recommend including the effects of Saturn, the Moon, and possibly also Venus in the delay modeling.

- **Scheduling with VieVS**

The module *vie\_sched* is the part of VieVS which designs the new scheduling algorithms to fully exploit the possibilities of the future VLBI2010 system. It considers a more uniform network and fast moving antennas. To support the development of *vie\_sched*, it is directly connected to VieVS to provide feedback on the quality of the schedules by thorough and realistic simulations (see Sun et al., 2011 [3]).

- **Combination with ringlaser**

We have combined data from the “G” ring laser gyroscope in Wettzell with VLBI observations in order to estimate Earth orientation parameters with hourly resolution. The details about the combination procedure and the results were summarized by Nilsson et al. (2012, [2]). Since the accuracy of the ring laser currently is about one order of magnitude worse than that of VLBI, the ring laser data normally do not contribute significantly to the combination, and the results are not improved compared to using only VLBI data. However, the combination with ring laser data would significantly improve the results if the accuracy of the ring laser was higher and/or data from more than one ring laser was used.

#### 4. Future Plans

In 2012 we will continue the development of VieVS, with special focus on spacecraft tracking and scheduling. Additionally, we will contribute to the ongoing activities within VLBI2010 and Earth orientation, and reference system studies will be carried out. Other goals are to organize a third VieVS User Workshop and to equip VieVS with a Kalman filter solution.

#### Acknowledgements

We are very grateful to the Austrian Science Fund (FWF) for supporting our work by projects P21049 (‘SCHED2010’), P22203 (‘MDION’) and P23143 (‘Integrated VLBI’). We also acknowledge the German Research foundation (DFG) for funding project SPEED2 (SCHU 1103/3-2).

#### References

- [1] Böhm, S., Brzezinski, A., Schuh, H., Complex demodulation in VLBI estimation of high frequency Earth rotation components, *Journal of Geodynamics*, published online, doi: 10.1016/j.jog.2011.10.002, 2012.
- [2] Nilsson, T., Böhm, J., Schuh, H., Schreiber, U., Gebauer, A., Klügel, T., Combining VLBI and ringlaser observations for determination of high frequency earth rotation variation, *J. Geodyn.*, submitted 2012.
- [3] Sun, J., Pany, A., Nilsson, T., Böhm, J., Schuh, H., Status and future plans for the VieVS scheduling package, in: W. Alef, S. Bernhart, A. Nothnagel (eds.) *Proceedings of the 20th Meeting of EVGA*, pp. 44-48, 2011.
- [4] Spicakova, H., Böhm, J., Plank, L., Nilsson, T., Schuh, H., Atmospheric Effects on VLBI-derived Terrestrial and Celestial Reference Frames, in: P. Willis (ed.) *Proceedings of the IAG Symposium 2011*, Melbourne, submitted 2012.

# Italy INAF Analysis Center Report

*M. Negusini, P. Sarti*

## Abstract

This report summarizes the activity of the Italian INAF VLBI Analysis Center. Our Analysis Center is located in Bologna, Italy and belongs to the Institute of Radioastronomy, which is part of the National Institute of Astrophysics. IRA runs the observatories of Medicina and Noto, where two 32-m VLBI AZ-EL telescopes are situated. This report contains the AC's VLBI data analysis activities and shortly outlines the investigations into the co-location of space geodetic instruments.

## 1. Current Status and Activity

Investigations into VLBI local tie surveying and antenna deformation continued in 2011. The impact of different contributing effects on the tie vector estimate has been simulated and evaluated. In particular, different local ground control network geometries, a varying number and distribution of ground pillars, the impact of the observing scheme adopted during the terrestrial survey, the impact of the redundancy of observations, the contribution of thermal and gravitational deformations of the space geodetic instrument structure were introduced into the tie vector computation, and their effects on the tie vector estimate were precisely evaluated [1]. In addition, a thorough investigation of the local stability of the geodetic monuments at the Medicina site and the determination of local, intra-site motions are currently in process. The starting data sets are those acquired during the terrestrial surveys of the GPS-VLBI tie vector during the period 2001 - 2010. The results derived by the analysis of the terrestrial data have been cross-checked against those obtained by the analysis of the GPS data acquired by the two permanent EUREF [2] stations MEDI and MSEL over the period 2004 - 2010. The results show a non-negligible, statistically significant motion of the local ground control network pillars, especially in the horizontal components, and are being summarized in a paper that has been almost finalized and is about to be submitted.

## 2. Data Analysis and Results

The IRA started to analyze VLBI geodetic databases in 1989, using a CALC/SOLVE package on the HP1000 at the Medicina station. In subsequent years, the same software was installed first on an HP360 workstation and later on an HP715/50 workstation. In more recent years, two HP785/B2600 workstations and an HP282 workstation were used. In 2007, a new Linux workstation was set up for the migration of all the VLBI data analysis, and Mark 5 Calc/Solve was installed. During 2011, we stored all the 1999 - 2011 databases available on the IVS Data Centers. All the databases were processed and saved with the best selection of parameters for the final arc solutions. The most recent IRA solution for crustal deformation comprises all Europe sessions analyzed at IRA from 1987 to 2009; the estimated horizontal and vertical velocities are presented in [3].

Our Analysis Center has participated in the IVS TROP Project on Tropospheric Parameters since the beginning of the activities. Tropospheric parameters (wet and total zenith delay and horizontal gradients) of all IVS-R1 and IVS-R4 24-hour VLBI sessions were regularly submitted in the form of SINEX files. INAF solutions for the CONT08 campaign were used for intra-technique combination and the results published in [4]. In 2011 we regularly submitted our results to IVS.

### 3. Outlook

We will continue with the regular submission of INAF tropospheric parameters to the IVS Data Centers, also studying the impact of the Vienna Mapping Function on the geodetic results. We will submit a long time series of troposphere parameters using all VLBI sessions available in our catalog in order to estimate the variations over time of the content of water vapor in the atmosphere.

### References

- [1] Abbondanza, C. and Sarti, P. (2012). Impact of network geometry, observation schemes and telescope structure deformations on local ties: simulations applied to Sardinia Radio Telescope. *J Geodesy*, doi: 10.1007/s00190-011-0507-6.
- [2] Bruyninx, C. (2004). The EUREF Permanent Network; a Multidisciplinary Network Serving Surveyors as well as Scientists. *GEOInformatics* 7(5), 32-35.
- [3] Sarti, P., M. Negusini, C. Abbondanza. (2010) Improved geodetic European very-long-baseline interferometry solution using models of antenna gravitational deformation. *Ann Geophys* 53(5-6) doi 10.4401/ag-4739.
- [4] Heinkelmann, R., J. Boehm, S. Bolotin, G. Engelhardt, R. Haas, R. Lanotte, D. Macmillan, M. Negusini, E. Skurikhina, O. Titov, H. Schuh. (2011) Vlbi-Derived Troposphere Parameters During Cont08. *J. Geodesy* 85(7); 377-393, Issn: 0949-7714, Doi: 10.1007/S00190-011-0459-X

# JPL VLBI Analysis Center Report for 2011

*Chris Jacobs*

## Abstract

This report describes the activities of the JPL VLBI Analysis Center for the year 2011. We continue to do celestial reference frame, terrestrial reference frame, earth orientation, and spacecraft navigation work using the VLBI technique. In 2011 we continued to collect reference frame data at 448 Mbps. Our work to build a reference at X/Ka-bands (8.4/32 GHz) is close to ppb accuracy. We supported several missions with VLBI navigation measurements. We continue to study ways to improve spacecraft tracking using VLBI techniques.

## 1. General Information

The Jet Propulsion Laboratory (JPL) Analysis Center is in Pasadena, California. Like the rest of JPL, the center is operated by the California Institute of Technology under contract to NASA. JPL has done VLBI analysis since about 1970. We focus on spacecraft navigation, including:

1. Celestial Reference Frame (CRF) and Terrestrial Reference Frame (TRF) are efforts which provide infrastructure to support spacecraft navigation and Earth orientation measurements.
2. Time and Earth Motion Precision Observations (TEMPO) measures Earth orientation parameters based on single baseline semi-monthly measurements. These VLBI measurements are then combined with daily GPS measurements as well as other sources of Earth orientation information. The combined product provides Earth orientation for spacecraft navigation.
3. Delta differenced one-way range ( $\Delta$ DOR) is a differential VLBI technique which measures the angle between a spacecraft and an angularly nearby extragalactic radio source. This technique thus complements the radial information from spacecraft doppler and range measurements by providing plane-of-sky information for the spacecraft trajectory.
4.  $\Delta$ VLBI phase referencing uses the VLBA to measure spacecraft positions.

## 2. Technical Capabilities

The JPL Analysis Center acquires its own data and supplements it with data from other centers. The data we acquire are taken using NASA's Deep Space Network (DSN).

1. Antennas: Most of our work uses 34-m antennas located near Goldstone (California, USA), Madrid (Spain), and Tidbinbilla (Australia). These include the following Deep Space Stations (DSS): the "High Efficiency" subnet comprised of DSS 15, DSS 45, and DSS 65 (see Figure 1) which has been the most often used set of antennas for VLBI. More recently, we have used the DSN's beam waveguide (BWG) antennas: DSS 13, DSS 24, DSS 25, DSS 26, DSS 34, DSS 54, and DSS 55. Less frequent use is made of the DSN's 70-m network (DSS 14, DSS 43, DSS 63). Typical X-band system temperatures are 35K on the HEF antennas. The 70-m and BWGs are about 20K. Antenna efficiencies are typically well above 50% at X-band.

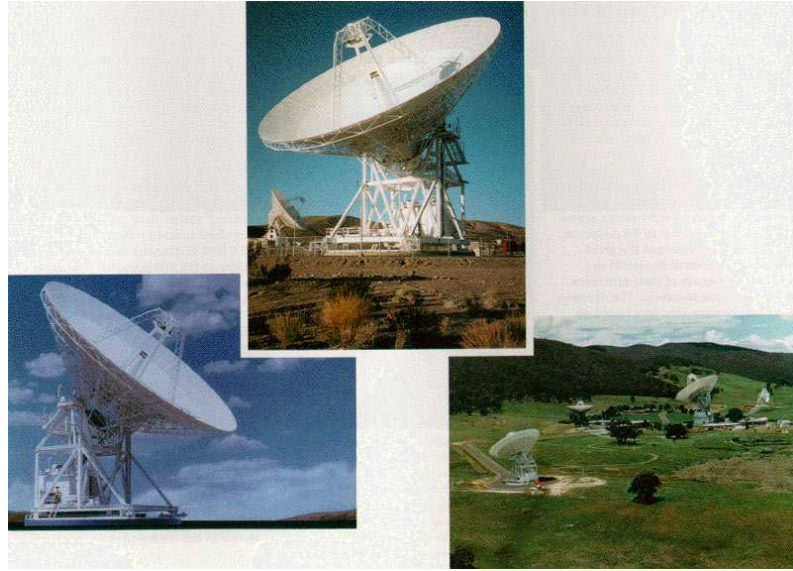

Figure 1. The three ‘high-efficiency’ DSN antennas: Goldstone (center); Robledo, Spain (lower left); and Tidbinbilla, Australia (lower right). These antennas were completed before 1986 for the Voyager Uranus encounter. In the 1990s, Ka-band (32 GHz) BWG antennas (not shown) were added.

2. Data acquisition: We use the Mark 5A VLBI data acquisition systems. In addition, we have JPL-unique systems called the VLBI Science Recorder (VSR) and the Wideband VSRs (WVSR) which have digital baseband converters and record directly to hard disk. The data are later transferred via network to JPL for processing with our software correlator.
3. Correlators: JPL VLBI Correlator has been exclusively based on the SOFTC software, which handles the  $\Delta$ DOR, TEMPO, and CRF correlations as well as tests of antenna arraying.
4. Solution types: We run several different types of solutions. For  $\Delta$ DOR spacecraft tracking we make narrow field ( $\approx 10^\circ$ ) differential solutions. The TEMPO solutions typically have a highly constrained terrestrial (TRF) and celestial frame (CRF) as a foundation for estimating Earth orientation parameters. These reference frames are produced from global solutions which then provide the framework needed for use by TEMPO and  $\Delta$ DOR.

### 3. Staff

Our staff are listed below along with areas of concentration. Note that not all of the staff listed work on VLBI exclusively, as our group is involved in a number of projects in addition to VLBI.

- Durgadas Bagri: VLBI instrumental calibrations and TEMPO.
- Jim Border:  $\Delta$ DOR spacecraft tracking.
- Cristina Garcia-Miro: Field support of VLBI experiments at Madrid.
- Shinji Horiuchi: Field support of VLBI experiments at Canberra.
- Chris Jacobs: S/X, K, Q, X/Ka CRFs, and TRF.

- Peter Kroger:  $\Delta$ DOR spacecraft tracking.
- Gabor Lanyi: VLBA phase referencing,  $\Delta$ DOR, WVR, K-Q CRF, and TRF.
- Steve Lowe: Software correlator, fringe fitting software,  $\Delta$ DOR.
- Walid Majid:  $\Delta$ DOR, VLBA phase referencing.
- Chuck Naudet: WVR, Mark 5A support, and K-Q CRF.
- Andres Romero-Wolf:  $\Delta$ DOR, CRF, and TRF. Maintains MODEST analysis code.
- Lawrence Snedeker: Field support of VLBI experiments at Goldstone.
- Ioana Sotuela: Field support of VLBI experiments and antenna calibration at Madrid.
- Ojars Sovers: S/X, K, Q, and X/Ka CRFs and TRF. Maintains MODEST analysis code.
- Alan Steppe: TEMPO and TRF.

#### 4. Current Status and Activities

X/Ka-band (8.4/32 GHz) CRF work continues along with S/X CRF and TEMPO EOP work.

VLBI spacecraft tracking continues to provide measurements of angular position in support of mission navigation and planetary ephemeris development. The ESA mission Rosetta was supported for its deep space maneuver in February. The Messenger spacecraft was guided into orbit about Mercury in March. Dawn was guided to a rendezvous with asteroid Vesta in May. Delta-DOR measurements of the Deep Impact spacecraft were taken in conjunction with ranging to verify that the DSN can uplink a ranging signal from one complex and then receive it at a second complex. This scenario is needed for later New Horizons support, when the round trip light time will be so great that a ranging signal transmitted by one complex cannot return before the complex has rotated out of view. The New Horizons trajectory toward Pluto was verified in June. The JAXA mission Planet-C was supported during its engine checkout in October – November. Monthly measurements of MRO and Mars Odyssey continue to improve the ephemeris of Mars. Juno and MSL were launched in late 2011 and will be heavily supported with Delta-DOR in 2012.

#### 5. Future Plans

In 2012, we hope to improve TEMPO and reference frame VLBI by increasing data rates to 2048 Mbps. Operational Ka-band phase calibrators have been built and are planned for deployment in 2012. Work on the Digital Back End (DBE) continues. Our next generation fringe fitting program is also expected to come online. We anticipate refereed publications on our X/Ka celestial reference frame work. On the spacecraft front, we plan to continue supporting a number of operational missions while further improving techniques for using VLBI for spacecraft tracking.

#### Acknowledgements

The work described here was in part performed at the Jet Propulsion Laboratory, California Institute of Technology, under contract with the NASA. Copyright ©2012 California Institute of Technology. Government sponsorship acknowledged. This report is dedicated to Lyle J. Skjerve, who died in 2011. He supported Goldstone VLBI during four decades. He is missed.

## References

- [1] Bourda, G., P. Charlot, and C. S. Jacobs, 'Future Radio Reference Frames & Implications for Gaia Link,' Proc. ELSA Conf.: Gaia at the Frontiers of Astrometry, Sevres, France, 7–11 June 2010. eds. C. Turon, F. Meynadier, and F. Arenou, EAS Publications Series, 45 (2010) pp. 377–380, 15 Feb 2011. [http://ftp.hip.obspm.fr/gaia2010/IMG/pdf/Poster\\_Bourda.pdf](http://ftp.hip.obspm.fr/gaia2010/IMG/pdf/Poster_Bourda.pdf)
- [2] Heflin, M. B., C. S. Jacobs, O. J. Sovers, A. Moore, and S. Owen, 'Use of Reference Frames for Interplanetary Navigation at JPL,' REFAG-2010 Conference, Marne-La-Vallee, France, Oct 2010. [http://iag.ign.fr/abstract/pdf/Heflin\\_REFAG2010.pdf](http://iag.ign.fr/abstract/pdf/Heflin_REFAG2010.pdf)
- [3] Jacobs, C. S., J. E. Clark, C. Garcia-Miro, M. B. Heflin, S. Horiuchi, V. E. Moll, L. J. Skjerve, and O. J. Sovers, 'Celestial Reference Frame at X/Ka-Band,' REFAG-2010, Marne-La-Vallee, France, Oct 2010. [http://iag.ign.fr/abstract/pdf/Jacobs\\_REFAG2010.pdf](http://iag.ign.fr/abstract/pdf/Jacobs_REFAG2010.pdf)
- [4] Jacobs, C. S., J. E. Clark, C. Garcia-Miro, S. Horiuchi, L. J. Skjerve, and O. J. Sovers 'Celestial Reference Frame at X/Ka-Band,' Proc. 20th EVGA, Bonn, Germany, S. Bernhart, ed., 29–31 Mar 2011. [http://www.mpifr-bonn.mpg.de/div/meetings/20thEVGA/EVGA-Talks/Jacobs\\_XKa\\_110330.pdf](http://www.mpifr-bonn.mpg.de/div/meetings/20thEVGA/EVGA-Talks/Jacobs_XKa_110330.pdf)
- [5] Jacobs, C. S., J. E. Clark, C. Garcia-Miro, S. Horiuchi, I. Sotuela, 'The Contribution of X/Ka-band VLBI to Multi-wavelength Celestial Frame Studies,' Journees: Earth rotation, reference systems and celestial mechanics: Synergies of geodesy and astronomy" Vienna, Austria, 19-21 Sep 2011. <http://info.tuwien.ac.at/hg/meetings/journees11/abstracts.php>
- [6] Jacobs, C., U. Bach, F. Colomer, P. de Vincente, C. Garcia-Miro, J. Gomez-Gonzalez, S. Gulyaev, S. Horiuchi, R. Ichikawa, A. Kraus, G. Kronschnabl, J. Lopez-Fernandez, J. Lovell, W. Majid, T. Natusch, A. Neidhardt, C. Phillips, R. Porcas, A. Romero-Wolf, L. Saldana, U. Schreiber, I. Sotuela, H. Takeuchi, J. Trinh, A. Tzioumis, and V. Zharov, 'The Potential for a Ka-band Worldwide VLBI Network,' Journees Systemes de reference spatio-temporels, Vienna, Austria, 19-21 Sep 2011. [http://info.tuwien.ac.at/hg/meetings/journees11/Pres/S2/S2\\_07\\_Jacobs.pdf](http://info.tuwien.ac.at/hg/meetings/journees11/Pres/S2/S2_07_Jacobs.pdf)
- [7] Jacobs, C. S., J. E. Clark, C. Garcia-Miro, S. Horiuchi, I. Sotuela, 'A Ka-band Celestial Reference Frame with Applications to Deep Space Navigation,' Ka and Broadband Communications: Navigation and Earth Observation Conference, Palermo, Italy, 3 Oct 2011. <http://www.kaconf.org/>
- [8] Lanyi, G., 'Quadruply Differenced One-Way Ranging: QDOR, IPN PR 42-186, pp. 1-15, 2011. [http://tmo.jpl.nasa.gov/progress\\_report/42-186/186A.pdf](http://tmo.jpl.nasa.gov/progress_report/42-186/186A.pdf)
- [9] Lowe, S. T., 'A Measurement of X-Band Front-End Phase Dispersion for Delta-Differenced One-Way Range (DDOR) Experiments,' IPN PR 42-184, pp. 1-15, 2011. [http://tmo.jpl.nasa.gov/progress\\_report/42-184/184B.pdf](http://tmo.jpl.nasa.gov/progress_report/42-184/184B.pdf)
- [10] Ma, C., A. Andrei, G. Bourda, and C.S. Jacobs, 'Celestial Frames at Multiple Wavelengths,' JENAM, St. Petersburg, Russia, 4–8 July 2011. <http://jenam2011.org/c4onf/>
- [11] Navarro, R., S. Rogstad, J. Trinh, C. Jacobs, 'Implementation Issues and Choices for VLBI Data Acquisition System in DSN,' 9th U.S. VLBI Technical Meeting, Socorro, NM, 01 Nov 2011. [http://www.aoc.nrao.edu/~jromney/9th\\_US\\_VLBI/navarro\\_JPL](http://www.aoc.nrao.edu/~jromney/9th_US_VLBI/navarro_JPL)
- [12] Sotuela, I., C. S. Jacobs, J. E. Clark, C. Garcia-Miro, S. Horiuchi, O. J. Sovers, 'Contribution of X/Ka-band VLBI to Multi-wavelength Celestial Frame Studies,' GREAT-ESF, Porto, Portugal, June 2011. [http://www.fc.up.pt/great-ws-porto/Ioana\\_Sotuela.pdf](http://www.fc.up.pt/great-ws-porto/Ioana_Sotuela.pdf)
- [13] Romero-Wolf, A. and C. S. Jacobs, 'Correlated Noise processing of VLBI data,' Journees: Systemes de reference spatio-temporels: Earth rotation, reference systems and celestial mechanics: Synergies of geodesy and astronomy" Vienna, Austria, 19-21 Sep 2011. [http://info.tuwien.ac.at/hg/meetings/journees11/Pres/S2/S2\\_09\\_Romero-Wolf.pdf](http://info.tuwien.ac.at/hg/meetings/journees11/Pres/S2/S2_09_Romero-Wolf.pdf)

# KASI Combination Center Report

*Younghee Kwak, Jungho Cho*

## Abstract

This report introduces the activities of the Korea Astronomy and Space Science Institute (KASI) as an IVS Combination Center and shows the current status of the combination work. It also outlines the intended tasks for 2012.

## 1. General Information

KASI was accepted as an IVS Combination Center in October 2008 and has prepared for regular combination operation. The KASI Combination Center combines the sessionwise products of the IVS Analysis Centers (ACs) into a final combination product.

## 2. Component Description

The missions of the KASI Combination Center are to create high quality combination products, to verify the combination solution of the BKG/DGFI Combination Center through cross-checking, to control the quality of the ACs' results, to provide feedback to the Analysis Centers, and to adhere to the IERS Conventions. We combine the products of individual IVS ACs at the normal equation level using the Bernese GPS Software (S/W) Version 5.0. Since the software has been developed for GPS data processing and analysis by the Astronomical Institute, University of Bern (AIUB), we have modified the software to deal with IVS analysis products properly.

## 3. Staff

The staff members of the KASI Combination Center are listed below.

Table 1. Personnel of the KASI Combination Center.

Jungho Cho	+82-42-865-3234	jojh@kasi.re.kr
Younghee Kwak	+82-42-865-2031	bgirl02@kasi.re.kr

## 4. Current Status and Activities

The Bernese S/W provides the functions of stacking Normal Equations (N.E.) and estimating parameters. The inputs to the Bernese S/W are the N.E. matrices and the N.E. vectors from the daily SINEX files of the individual ACs. The outputs are daily SINEX files including combined station coordinates and Earth Orientation Parameters (EOPs).

In order to validate the modified Bernese S/W, we reanalyzed solutions of BKG, GSFC, and OPA (Table 2) that use identical analysis software, Calc/Solve, and combined them. As a prepara-



tory combination analysis, we also combined IVS analysis products of six ACs — BKG, DGFI, GSFC, IAA, OPA, and USNO (Table 2) — and then compared the residuals of individual solutions with respect to the combination solution.

Table 2. Products of individual ACs for the combination.

AC	BKG	DGFI	GSFC	IAA	OPA	USNO
Solution	bkg2010a	dgf2009a	gsf2010a	iaa2010a	opa2010a	usn2007b

#### (1) Test combination with 3ACs

The solutions of 144 sessions, especially XA and XE code sessions, in 2008 were combined. The outliers were not excluded in this combination. We solely compared X-pole, Y-pole, UT1, and their rates of individual solutions with respect to those of combined solutions. The residuals between individual solutions and the combined solution are shown in Figure 1. The Root-Mean-Squares (RMS) and biases of the residuals are shown in Table 3. As all three ACs use Calc/Solve, the combined solution agrees well with individual solutions except for the rates of polar motion. There are systematic variations between individual and combined solutions. We expect that they are caused by inappropriate a priori values or nutation definition.

#### (2) Full combination with 6ACs

We combined six main AC solutions. Figure 2 shows the residuals between individual solutions and the combined solution, and Table 4 shows their RMS and biases. In the combination, we excluded severe outliers. The RMS of the residuals are around 300 microarcseconds ( $\mu as$ ) for polar motion, 10 microseconds ( $\mu s$ ) for UT1, 300 microarcseconds/day ( $\mu as/d$ ) for polar motion rates, and 20  $\mu s$  for LOD. This accuracy level still is inferior to that of current BKG/DGFI Combination Center[1]. The systematic variation patterns of polar motion rates are similar with 3ACs combination.

## 5. Future Work for 2012

Our future work in 2012 is as follows:

- Weighting the individual solutions
- Combining whole period IVS products (1984-present)
- Comparing with BKG/DGFI Combination Center, IERS 08C04, and IGS solutions
- Providing IVS EOP format solutions (Rapid and Quarterly)

## References

- [1] <http://ida.bkg.bund.de/IVS/index.html>  
BKG/DGFI Combination Center Web page.

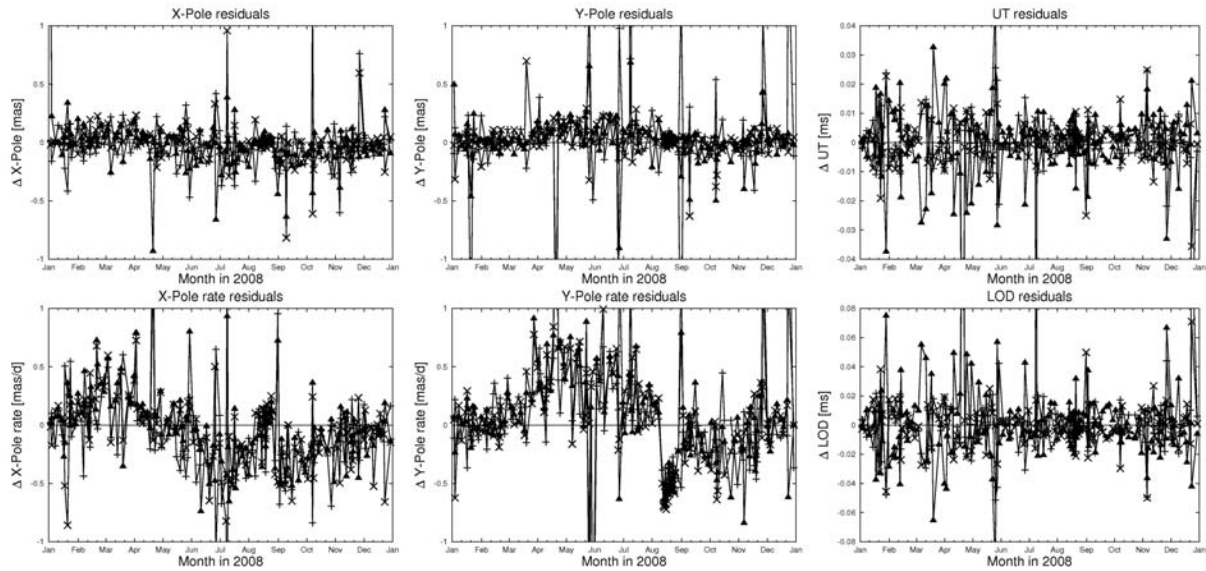

Figure 1. Internal comparison between individual solutions and KASI combination solution (Individual solutions - Combined solution). + : BKG, × : GSFC, ▲ : OPA.

Table 3. RMS and offset of the residuals between individual solutions and the combined solution.

RMS /Offset	X-Pole (mas)	Y-Pole (mas)	UT1 (ms)	X-Pole rate (mas/d)	Y-Pole rate (mas/d)	LOD (ms)
BKG <sub>KAS</sub>	0.193	0.329	0.018	0.335	0.702	0.035
-COM <sub>KAS</sub>	/-0.025	/0.055	/-0.002	/-0.049	/0.069	/0.003
GSF <sub>KAS</sub>	0.163	0.432	0.013	0.308	0.481	0.025
-COM <sub>KAS</sub>	/-0.008	/0.011	/-0.001	/-0.066	/0.086	/0.001
OPA <sub>KAS</sub>	0.263	0.236	0.016	0.345	0.592	0.032
-COM <sub>KAS</sub>	/-0.019	/0.007	/0.000	/-0.015	/0.068	/0.001

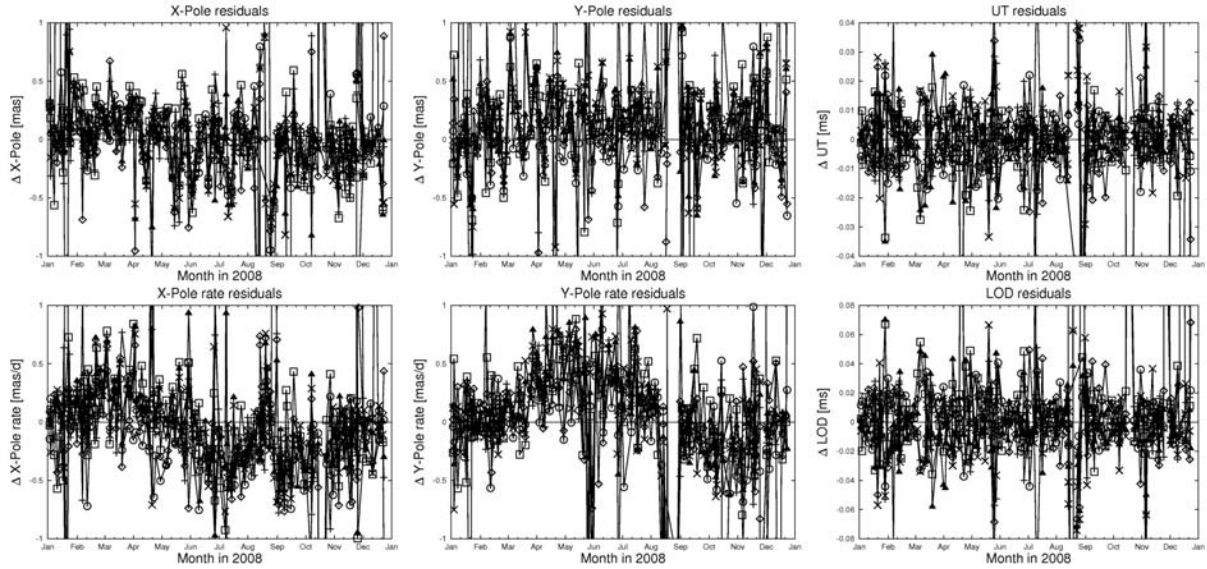

Figure 2. Internal comparison between individual solutions and KASI combination solution (Individual solutions - Combined solution). + : BKG,  $\diamond$  : DGFI,  $\times$  : GSFC,  $\square$  : IAA,  $\blacktriangle$  : OPA,  $\circ$  : USNO

Table 4. RMS and offset of the residuals between individual solutions and the combined solution.

RMS /Offset	X-Pole (mas)	Y-Pole (mas)	UT1 (ms)	X-Pole rate (mas/d)	Y-Pole rate (mas/d)	LOD (ms)
$BKG_{KAS}$	0.325	0.350	0.010	0.323	0.290	0.021
$-COM_{KAS}$	/-0.034	/0.130	/0.002	/-0.054	/0.072	/-0.003
$GSF_{KAS}$	0.282	0.340	0.010	0.308	0.373	0.021
$-COM_{KAS}$	/-0.012	/0.124	/0.001	/-0.034	/0.118	/-0.003
$OPA_{KAS}$	0.291	0.331	0.011	0.320	0.361	0.023
$-COM_{KAS}$	/-0.046	/0.119	/0.001	/-0.010	/0.129	/-0.002
$DGF_{KAS}$	0.276	0.312	0.011	0.334	0.320	0.021
$-COM_{KAS}$	/-0.029	/0.077	/0.000	/-0.045	/0.112	/0.000
$IAA_{KAS}$	0.283	0.380	0.011	0.372	0.360	0.022
$-COM_{KAS}$	/0.014	/0.160	/-0.001	/-0.039	/0.135	/0.003
$USN_{KAS}$	0.264	0.294	0.008	0.334	0.335	0.016
$-COM_{KAS}$	/0.031	/0.024	/-0.001	/-0.162	/0.000	/0.003

# KTU-GEOD IVS Analysis Center Annual Report 2011

*Emine Tanır Kayıkçı, Kamil Teke*

## Abstract

This report summarizes the activities of the KTU-GEOD IVS Analysis Center (AC) in 2011 and outlines the planned activities for the year 2012. Analysis of the EUROPE sessions is one of our specific interests. Combination of different AC solutions for continuous VLBI sessions, e.g., CONT11 sessions, will be investigated.

## 1. General Information

The KTU-GEOD IVS Analysis Center (AC) is located at the Department of Geomatics Engineering, Karadeniz Technical University, Trabzon, Turkey.

## 2. Staff at KTU-GEOD Contributing to the IVS Analysis Center

Members who are contributing to research of the KTU-GEOD IVS Analysis Center (AC) in 2011 are listed in Table 1 (in alphabetical order) by their main focus of research and working location:

Table 1. Staff members.

Name and Email	Working Location	Main Focus of Research
Emine Tanır Kayıkçı etanir@ktu.edu.tr	Karadeniz Technical University, Department of Geomatics Engineering, Trabzon, Turkey	responsibility for Analysis Center work and data processing
Kamil Teke kteke@hacettepe.edu.tr	Hacettepe University, Department of Geodesy and Photogrammetry Engineering, Ankara, Turkey	data processing

## 3. Current Status and Activities

During 2011 we focused on things outside IVS. In 2012 we plan to return to IVS activities.

## 4. Future Plans

We will continue to analyze VLBI sessions with different parameterizations, focusing on the EUROPE sessions by using VieVS software. In 2012, combination of different AC solutions for continuous VLBI sessions, e.g., CONT11 sessions, will be investigated.

## **Acknowledgements**

We are thankful to all the governing board of IVS. We are grateful to Karadeniz Technical University for their financial support of KTU-GEOD IVS AC research activities.

# IVS Analysis Center at Main Astronomical Observatory of National Academy of Sciences of Ukraine

*Yaroslav Yatskiv*

## Abstract

This report summarizes the activities of the VLBI Analysis Center at the Main Astronomical Observatory of the National Academy of Sciences of Ukraine in 2011.

## 1. Introduction

The VLBI Analysis Center was established in 1994 by the Main Astronomical Observatory (MAO) of the National Academy of Sciences of Ukraine (NASU) as a working group of the Department of Space Geodynamics of the MAO. In 1998 the group started its IVS membership as an IVS Analysis Center. The MAO AC is located at the office building of the observatory in Kiev.

## 2. Technical Description

VLBI data analysis at the center is performed on two computers: an Intel Core 2 Duo 3.1 GHz box with 4 GB RAM and a 1 TB HDD, and a Pentium-4 3.4 GHz box with 1 GB RAM and two 200 GB HDDs. Both computers are running under the Linux/GNU Operating System.

For data analysis we use the STEELBREEZE software which was developed at the MAO NASU. The STEELBREEZE software is written in the C++ programming language and uses the Qt 2.x widget library. STEELBREEZE makes Least Squares estimation of different geodynamical parameters with the Square Root Information Filter (SRIF) algorithm (see [1]).

The software analyzes VLBI data (time delays) of a single session or a set of multiple sessions. The time delay is modeled according to the IERS Conventions (2003) [2], as well as by using additional models (tectonic plate motion, nutation models, wet and hydrostatic zenith delays, mapping functions, etc.). The following parameters are estimated: Earth orientation parameters, coordinates and velocities of a selected set of stations, coordinates of a selected set of radio sources, clock function, and wet zenith delay.

## 3. Staff

The VLBI Analysis Center at Main Astronomical Observatory consists of the following members:

**Yaroslav Yatskiv:** Head of the Department of Space Geodynamics; general coordination and support of activity of the Center.

**Sergei Bolotin:** Scientific consultant on VLBI software development.

## 4. Current Status and Activities in 2011

In 2011 we performed regular VLBI data analysis to determine Earth orientation parameters. “Operational” solutions were produced and submitted to the IVS on a weekly basis. The IERS

Conventions (2003) [2] models were applied in the analysis. In the solutions, station coordinates and Earth orientation parameters were estimated.

Also, this year we continued to participate in the IVS Tropospheric Parameters project. Estimated wet and total zenith delays for each station were submitted to IVS. The analysis procedure was similar to the one used for the operational solutions.

## 5. Plans for 2012

The MAO Analysis Center will continue to participate in operational EOP determination, as well as in updating the TRF and CRF solutions from VLBI analysis of the full data set of observations.

## Acknowledgements

The work of our Analysis Center would be impossible without the activities of other components of IVS. We are grateful to all contributors from the Service.

## References

- [1] Biermann, G.J., 1977, Factorization Methods for Discrete Sequential Estimation, V128, Mathematics in Science and Engineering Series, Academic Press.
- [2] IERS Conventions (2003), IERS Technical Note 32, eds. D.D. McCarthy and G. Petit, Bundesamt für Kartographie und Geodäsie, Frankfurt am Main.

# Analysis Center at National Institute of Information and Communications Technology

*Thomas Hobiger, Ryuichi Ichikawa, Mamoru Sekido, Yasuhiro Koyama, Tetsuro Kondo*

## Abstract

This report summarizes the activities of the Analysis Center at the National Institute of Information and Communications Technology (NICT) for the year 2011.

## 1. General Information

The NICT Analysis Center is operated by the space-time standards group of NICT and is located in Kashima, Ibaraki, Japan as well as at the headquarters in Koganei, Tokyo. In April 2011 the space-time standards group, to which the VLBI group belongs, was re-organized under the Applied Electromagnetic Research Institute of NICT. Analysis of VLBI experiments and related study fields at our group are mainly concentrated on experimental campaigns for developing new techniques such as time and frequency transfer, e-VLBI for real-time EOP determination, analysis software development, prototyping of a compact VLBI system, and atmospheric path delay studies.

## 2. Staff

Members who are contributing to the Analysis Center at the NICT are listed below (in alphabetical order, with their working locations in parentheses):

- HOBIGER Thomas (Koganei, Tokyo): Analysis software development, time and frequency transfer, and atmospheric research
- ICHIKAWA Ryuichi (Kashima): Compact VLBI system and atmospheric modeling
- KONDO Tetsuro (Kashima): Software correlator
- KOYAMA Yasuhiro (Koganei, Tokyo): e-VLBI
- SEKIDO Mamoru (Kashima): International e-VLBI and VLBI for spacecraft navigation

## 3. Current Status and Activities

After the big earthquake on 11 March 2011, post-seismic crustal deformation has been regularly monitored by the Kashima (11 m) - Koganei (11 m) baseline since 7 May 2011. More details about these monitoring observations are described in [3].

### 3.1. Ultra-rapid EOP Experiments

In cooperation with Geospatial Information Authority of Japan (GSI), Onsala Space Observatory, and University of Tasmania, several ultra-rapid UT1 and EOP experiments were carried out. Since the single baseline between Onsala and Tsukuba only allows the determination of UT1 in real-time, first tests with a three-station network including Hobart were made in order to test the potential of obtaining all three Earth orientation parameters in near-real time. Therefore, the



automated analysis software (see section 3.3) needed to be adopted to handle automated ambiguity resolution of multi-baseline sessions and to allow for a robust estimation of the three EOP components. In addition to the dedicated ultra-rapid experiments, GSI regularly automatically submits c5++ processed UT1 results (see [2] for details on the processing strategy) from INT2 sessions to the IERS for test purposes.

### 3.2. Time and Frequency Transfer via VLBI

Space geodetic techniques like GNSS have been proven to be a useful tool for time and frequency transfer purposes. Besides SLR, which is currently tested under the name T2L2, VLBI could be another space geodetic technique that can be utilized for time and frequency transfer. Unlike GNSS, VLBI does not require any orbital information, as it directly refers to an inertial reference frame defined by the location of the quasi stellar objects. As summarized in [5], current VLBI systems can provide a frequency link stability of about  $2 \times 10^{-15}$  @ 1d (ADEV). But due to the fact that geodetic VLBI networks do not observe for more than 24h continuously, no statement about long-term stability can be made. Moreover, as VLBI only provides one observation per epoch, troposphere and station clocks need to be de-correlated in space geodetic analysis by estimating these parameters from a batch of several scans. Thus, VLBI can only contribute to frequency transfer with clock estimates made every 30 minutes or longer. In order to overcome this drawback, NICT's Space-Time Standards Laboratory has started to work on the realization of a time and frequency transfer system based on the principles of VLBI, whereas developments from the upcoming geodetic VLBI2010 system are expected to help to reach these goals. VLBI2010 is designed to provide observables with a few picoseconds of uncertainty, and once a global station network is deployed, it is expected to operate 24h/7d which would allow to access long-term frequency stability on intercontinental links. The VLBI2010 short-term frequency transfer limitation is thought to be overcome when VLBI is combined with GNSS (or TWSTFT) in the analysis processing. Based on simulation data (see Figure 1) we have started to evaluate the frequency transfer performance of the future VLBI2010 network. In parallel, system development has started at the Kashima Space Research Center facility.

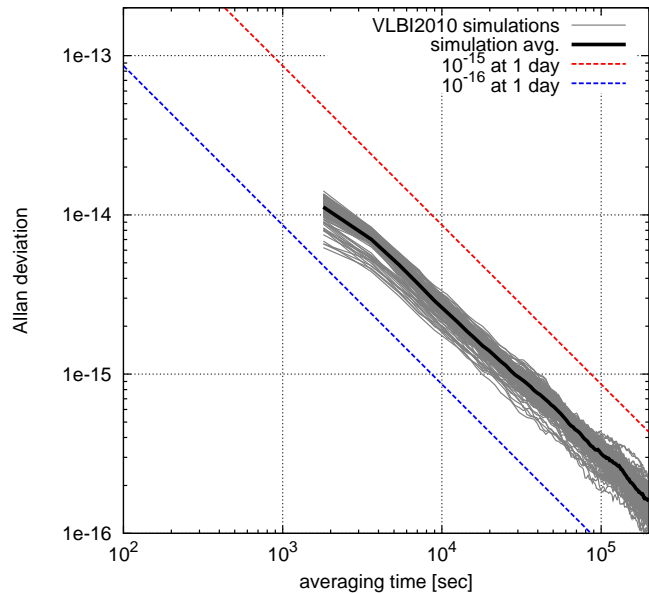

Figure 1. Frequency transfer performance over an 18 station global network of VLBI2010-like stations using a combination of 3 m and 10 m dishes. Simulated observations were kindly provided by the Vienna University of Technology.

### 3.3. Development of a Multi-technique Space-geodetic Analysis Software Package

c5++, which is a space-geodetic analysis software that includes SLR, GNSS and VLBI, has undergone several modifications and updates in the year 2011. First of all, the software has been made compatible with the IERS Conventions 2010 (see [4]), and its processing speed was improved. In addition, a SINEX interface has been added in order to output data for inter-comparison and submission of results. This interface can also be used to read a priori information (TRF, CRF, EOPs, etc.) which are also given in SINEX format. The VLBI module has been extended to handle unattended multi-station experiments, whereas a new simple and robust ambiguity resolution method has been implemented in order to ensure automated processing. This feature has been tested with three-station EOP experiments (see Section 3.1) and is currently undergoing an evaluation using large global VLBI networks. Further software updates include new features for real-time UT1 experiments [2] as well as a support for VMF1. In addition to the currently used least-squares estimation method, a Kalman filter is being implemented in c5++. Moreover,

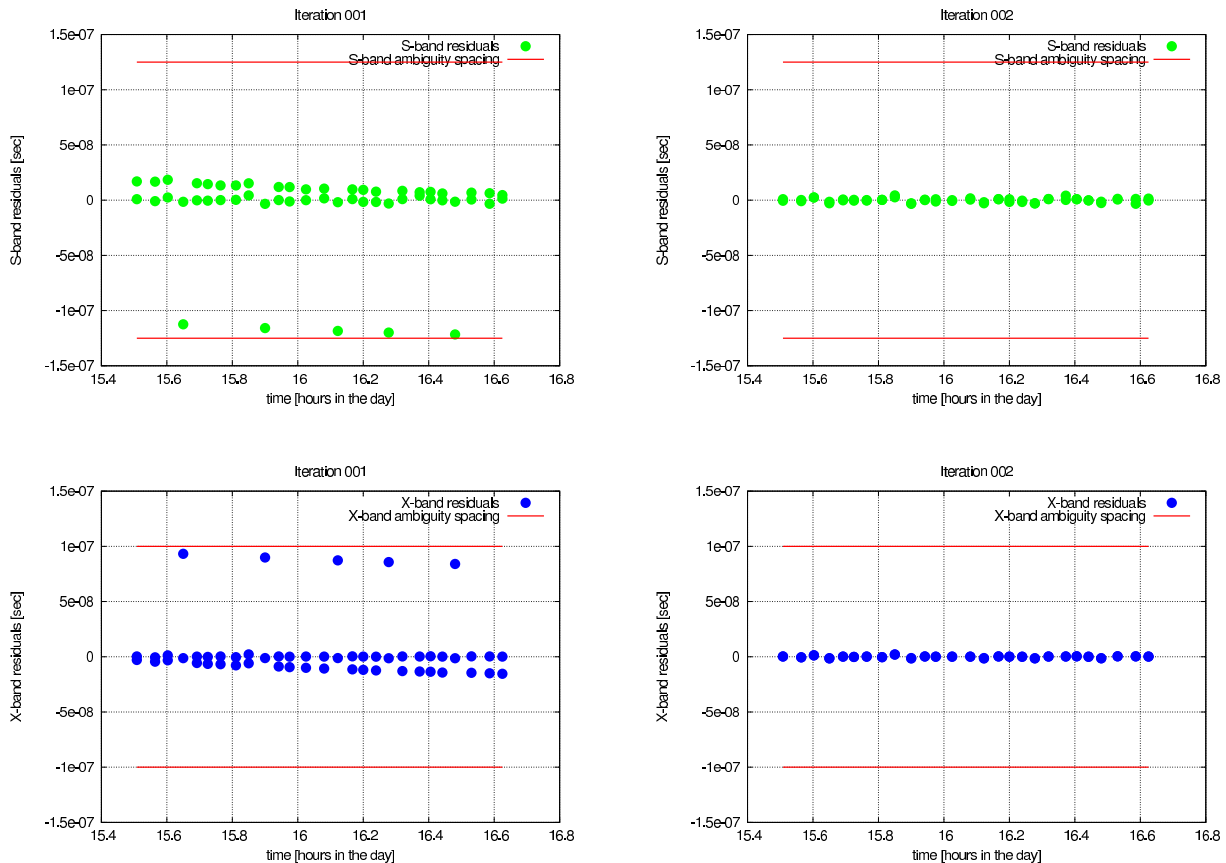

Figure 2. S-band (top) and X-band (bottom) residuals after the first (left) and second (right) iteration using the automated ambiguity resolution strategy applied to data from a three-station experiment (Onsala, Tsukuba, and Metsahovi) on September 4, 2007. For this example one can see that all ambiguities are resolved properly after two iterations.

dedicated time and frequency transfer and spacecraft navigation modules are being developed in order to support the research activities of NICT's VLBI project.

### 3.4. Ray-traced Troposphere Slant Delay Correction for Space Geodesy

A software package, called Kashima Ray-tracing Tools (KARAT), has been developed, and it is capable of transforming numerical weather model data sets to geodetic reference frames, computing fast and accurate ray-traced slant delays, and correcting geodetic data on the observation level. A thorough comparison of ray-traced troposphere delays with results from other space-geodetic techniques during CONT08 has been made by Teke et al. (2011, [6]). KARAT has been extended to support frequency dependency of the refractivity following the Liebe model [1] with the goal of finding out whether modern space-geodetic microwave techniques (including VLBI2010 and higher dual-frequency VLBI configurations) should be corrected for dispersive troposphere delays.

## 4. Future Plans

For the year 2012 the plans of the Analysis Center at NICT include:

- Time and frequency transfer simulations and experiments by VLBI and combination with other techniques like GPS or TWSTFT
- Further improvement of the multi-technique space-geodetic analysis c5++ software
- Experiments and analysis of multi-baseline network which allows the determination of all three EOPs in real-time
- Usage of multi-processors/multi-core processing platforms for the acceleration of space geodetic applications
- VLBI experiments for spacecraft tracking and its analysis

## References

- [1] Liebe, H.J., MPM-An atmospheric millimeter-wave propagation model, *Int. J. Infrared and Millimeter Waves*, 10, 631-650, 1989.
- [2] Hobiger T., T. Otsubo, M. Sekido, T. Gotoh, T. Kubooka and H. Takiguchi, Fully automated VLBI analysis with c5++ for ultra-rapid determination of UT1, *Earth, Planets, Space*, 45, 2, 75-79, 2010.
- [3] Ichikawa R. and M. Sekido, Kashima and Koganei 11-m VLBI Stations, this issue, 2012.
- [4] Petit G. and B. Luzum, IERS Conventions, *IERS Technical Note*, 36, 179 pp., 2010.
- [5] Rieck C., R. Haas, R.T.K. Jaldehag, and J.M. Johansson, VLBI time-transfer using CONT08 data, *Proceedings of the 6th IVS General Meeting*, 365-369, 2010.
- [6] Teke K., J. Boehm, T. Nilsson, H. Schuh, P. Steigenberger, R. Dach, R. Heinkelmann, P. Willis, R. Haas, S. G. Espada, T. Hobiger, R. Ichikawa and S. Shimizu, Multi-technique comparison of troposphere zenith delays and gradients during CONT08, *Journal of Geodesy*, 85, 7, 395-413, 2011..

# NMA Analysis Center

*Halfdan Pascal Kierulf and Per Helge Andersen*

## Abstract

The Norwegian Mapping Authority (NMA) has during the last few years had a close cooperation with FFI in the analysis of space geodetic data using the GEOSAT software. NMA has recently been given the status of an Associate Analysis Center of IVS (28 October 2010). The future GEOSAT activities at both institutions will be coordinated by NMA. This also implies that FFI will end being an IVS Associate Analysis Center in 2012. NMA's and FFI's contributions to the IVS as Analysis Centers focus primarily on 1) routine production of session-by-session unconstrained and consistent normal equations by GEOSAT as input to the IVS combined solution, and 2) a combined analysis at the observation level of data from VLBI, GPS (ground-based and LEO), SLR, DORIS, altimetry, accelerometry, and GRACE KBR. After the recent improvements, we expect that VLBI results produced with GEOSAT will be consistent with results from the other VLBI Analysis Centers to a satisfactory level.

## 1. Introduction

A number of co-located stations with more than one observation technique have been established. In principle, all instruments at a given co-located station move with the same velocity, and it should be possible to determine one set of coordinates and velocities for each co-located site. In addition, a constant eccentricity vector from the reference point of the co-located station to each of the individual phase centers of the co-located antennas is estimated using constraints in accordance with a priori information given by the ground surveys. One set of Earth orientation parameters (EOP) and geocenter coordinates can be estimated from all involved data types. The present dominating error source of VLBI is the water content of the atmosphere, which must be estimated. The introduction of GPS data with a common VLBI and GPS parameterization of the zenith wet delay and atmospheric gradients will strengthen the solution for the atmospheric parameters. The inclusion of SLR data, which is nearly independent of water vapor, gives new information which will help in the de-correlation of atmospheric and other solve-for parameters and lead to more accurate parameter estimates. These, and many more advantages with the combination of independent and complementary space geodetic data at the observation level, are fully provided by the GEOSAT software developed by FFI [1, 2].

## 2. The GEOSAT Software and Analysis Activities in 2011

The Norwegian Mapping Authority (NMA) and FFI have started a close cooperation in the analysis of space geodetic data using the GEOSAT software. NMA has recently been given the status of an Associate Analysis Center of IVS. The GEOSAT software is to be used in the analysis of VLBI data. In addition, there is a lot of activity going on at NMA and FFI to further develop the multi-technique software GEOSAT (see the FFI TDC 2011 annual report).

The NMA has in collaboration with FFI made a large effort to make the GEOSAT software compatible with other VLBI analysis software. The software is also in full compliance with the IERS 2010 Conventions [6].

One of the first challenges that had to be solved was how to extract an unconstrained SINEX solution from the Upper-Diagonal UD Kalman filter solution produced by GEOSAT. A first test

solution was sent to the IVS Combination Center in autumn 2009. During 2010 several solutions covering all VLBI sessions with at least four stations from the start of 1994 to the end of 2009 were submitted to the IVS Combination Center. The first solution was presented at the 6th IVS General Meeting, in Hobart, Australia [5]. The overall agreement between the NMA-GEOSAT solution and the solutions from the other ACs was satisfactory for this first comparison. However, some discrepancies were found. There were some systematic differences in the nutation parameters, which in our latest comparisons seem to have vanished. A misinterpretation of the NGS-format led to systematic differences in UT1-UTC. Systematic differences in station heights have also disappeared in the latest comparison mostly due to the use of the VMF1 [4] model instead of 3D ray tracing. We also noticed more noise in the GEOSAT-derived EOP compared to results from the other software packages. The largest “EOP-outliers” disappeared after some manual editing of the observations. Some other “EOP-outliers” were removed after a manual introduction of clock breaks in the analysis.

Our plan is to go through the VLBI data from the start of 1994 to the present and perform a detailed manual editing of outliers. We expect that this will contribute to a reduction of the EOP “noise level”. When the editing is completed, a new set of normal equations will be submitted to IVS for a test combination. We hope (and expect) that the results then will be at the level of the other IVS ACs.

As soon as the GEOSAT solution is in satisfactory agreement with the other solutions, NMA will start to deliver unconstrained normal equations in the SINEX format to the IVS Combination Center on a routine basis. Tests of different models are also planned, for instance, a comparison of results using VMF1 and 3D ray tracing.

To produce VLBI solutions for IVS [3] is the first part of a larger strategic plan from NMA. The next step is to include other geometric geodetic techniques (GNSS, SLR, and DORIS) in a common solution where the different techniques are combined at the observation level. The long-term goal of this large effort is to also include data from the gravity satellites GRACE and GOCE and from altimeter satellites.

### 3. Staff

Dr. Halfdan Pascal Kierulf - Research geodesist of the Norwegian Mapping Authority (NMA).  
Dr. Per Helge Andersen - Research Professor of Forsvarets forskningsinstitutt (FFI and NMA).  
Dr. Oddgeir Kristiansen - Section Manager at the Norwegian Mapping Authority (NMA).

### References

- [1] Andersen, P. H., 1995. High-precision station positioning and satellite orbit determination. PhD Thesis, *NDRE/Publication 95/01094*
- [2] Andersen, P. H., 2000. Multi-level arc combination with stochastic parameters. *Journal of Geodesy* 74: **531-551** (doi: 10.1007/s001900001115)
- [3] Böckmann, S., Artz, T., and Nothnagel, A. 2009, VLBI terrestrial reference contribution to ITRF2008. *Journal of Geodesy*, 84, **201-219** (doi: 10.1007/s00190-009-0357-7)
- [4] Boehm, J., Werl, B., and Schuh, H. 2006, Troposphere mapping functions for GPS and very long baseline interferometry from European Center for Medium-Range Weather Forecasts operational analysis data. *Journal of Geophysical Research*, 111, B02406, (doi:10.1029/2005JB003629)

- 
- [5] Kierulf, H.P., Andersen, P.-H., Boeckmann, S., and Kristiansen, O. 2010, VLBI analysis with the multi-technique software GEOSAT. *IVS 2010 General Meeting Proceedings*, Edited by Dirk Behrend and Karen D. Bayer (NASA/CP-2010-215864)
  - [6] Petit, G., and Luzum, B. (eds.), 2010. *IERS Conventions (2010)*. (IERS Technical Note; 36) Frankfurt am Main: Verlag des Bundesamts für Kartographie und Geodäsie. 179 pp., paperback, in print
  - [7] Petrov, L., and Boy, J.-P. 2004. Study of the atmospheric pressure loading signal in VLBI observations, *Journal of Geophysical Research*, (doi: 10.1029/2003JB002500)

# Paris Observatory Analysis Center OPAR: Report on Activities, January - December 2011

*Sébastien B. Lambert*

## Abstract

We report on activities of the Paris Observatory VLBI Analysis Center (OPAR) for calendar year 2011 concerning the development of operational tasks and the Web site.

## 1. Operational Activities

### 1.1. 2011a Base Solution

A reanalysis of the complete 24-hour session database was done (2011a) and resulting EOP series and radio source catalogs were sent to the IVS. This solution estimated EOP and rates as session parameters, station coordinates and velocities as global parameters, and most of the sources' coordinates as global parameters. Troposphere and clock parameters were estimated every 20 min and 60 min, respectively, and gradients were estimated every six hours except for a list of 105 stations having a non-sufficient observational history. Axis offsets were estimated as global parameters for a list of 77 stations. We used up-to-date geophysical and astronomical modeling to compute the theoretical delay and partials, including the IAU 2006 nutation and precession, the Vienna mapping functions 1, the FES 2004 ocean loading model, and the antenna thermal deformations as provided by A. Nothnagel (2009, *J. Geod.*, 83, 787). Since the solution was released after the 11 March 2011 earthquake in Japan, the displacement of the 32-m antenna at Tsukuba was modeled by splines, as done earlier for Fairbanks and the TIGO antenna at Concepción. We used the latest version of the Calc/Solve geodetic VLBI analysis software package. More details can be found at

<http://ivsopar.obspm.fr/earth/glo>

### 1.2. Station and Radio Source Coordinate Time Series

Station and radio source coordinate time series were also produced. For each source, a page displays plots of original and smoothed time series and provides links to source information of various external databases (e.g., the French Virtual Observatory software package Aladin that permits someone to get the optical counterpart of the VLBI quasars, or the Bordeaux VLBI Image Database that gives the VLBI structure).

### 1.3. Operational Solutions

24-hour sessions were analyzed routinely within 24 hours after the version 4 database was submitted to the IVS. The operational solution was aligned to the 2011a global solution. Unconstrained normal equations relevant to EOP, rates, and station and source coordinates were sent to the IVS in SINEX format for combination in the framework of the IVS Analysis Coordinator's task.

Two operational solutions (2011i and 2011j) analyzing Intensive sessions after 2006 were also submitted to the IVS together with corresponding SINEX files. The solution 2011i processed

Intensive sessions in order to produce UT1 consistent with VTRF 2008a, ICRF2, and C04 Earth orientation data. The solution 2011j processed Intensive sessions in order to produce UT1 but is overparameterized (station coordinates and troposphere delays are also estimated together with UT1) and produces postfit rms delays as low as for the 24-hr sessions, i.e., lower than 2011i by a factor of two. In both solutions, due to the 11 March, 2011 earthquake in Japan, data points obtained from the analysis of the Tsukuba-Wetzell baseline should not be used.

All the above products, except SINEX files, were also published on the OPAR Web site. SINEX files were only sent to the data centers.

## 2. Follow-up of Various Phenomena

### 2.1. Free Core Nutation

The free core nutation (FCN) is a free oscillation of the Earth's figure axis in space due to the presence of a liquid core rotation inside the viscoelastic mantle. Its period is close to 430 days and is retrograde. Understanding the excitation of the FCN and its amplitude and phase variations is still an open question, although the community generally believes that the key resides in improved atmospheric and oceanic circulation modeling at diurnal and subdiurnal frequencies. At OPAR, we maintain an FCN model directly fitted to routinely estimated nutation offsets (Figure 1).

In addition to the FCN, amplitudes and phases of a set of 42 prograde and retrograde tidal waves are also fitted to the data. These tidal terms are interpreted as small deficiencies of the IAU 2000A nutation model. More explanations and material can be found at

<http://ivsopar.obspm.fr/earth/geo>

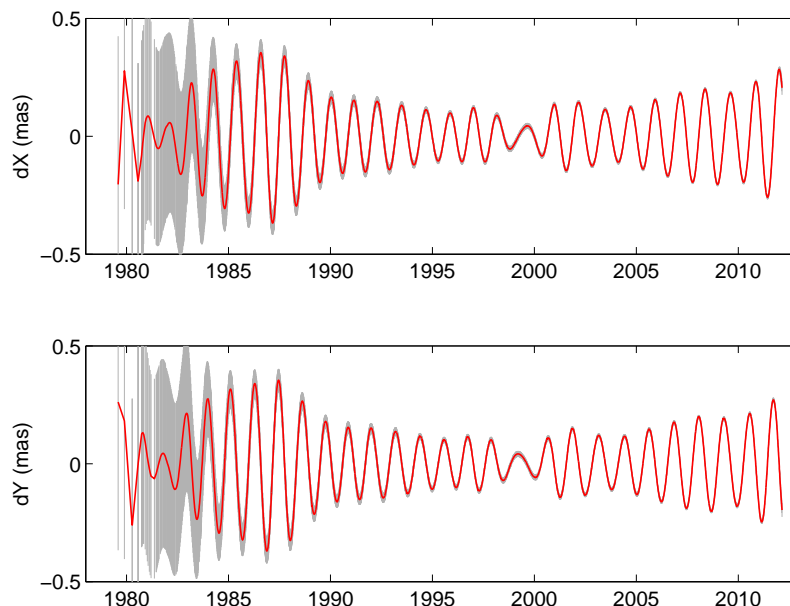

Figure 1. The free core nutation fitted to opa2010d nutation offsets with respect to the IAU 2006 nutation and precession models.



## 2.2. Displacement of TIGO at Concepción and of the Tsukuba Radio Telescope

Still using the routinely analyzed 24-hour sessions, we monitored the displacements of the station of TIGO at Concepción after the 27 February 2010 earthquake and of the radio telescope at Tsukuba after the 11 March 2011 earthquake. Figure 2 displays the UEN coordinates of the two sites with respect to the mean position as given in the VTRF 2008a. The monitoring is continued at

<http://ivsopar.obspm.fr/earth/tigo>

<http://ivsopar.obspm.fr/earth/tsukuba>

## 3. Staff Members

Staff members who contributed to the OPAR analysis and data centers in 2011 are listed below:

- Sébastien Lambert, Analysis Center manager, responsible for data analysis, development of GLORIA analysis software,
- Christophe Barache, Data Center manager, data analysis,
- Daniel Gambis, responsible for the IERS Earth Orientation Center, interface with IERS activities.

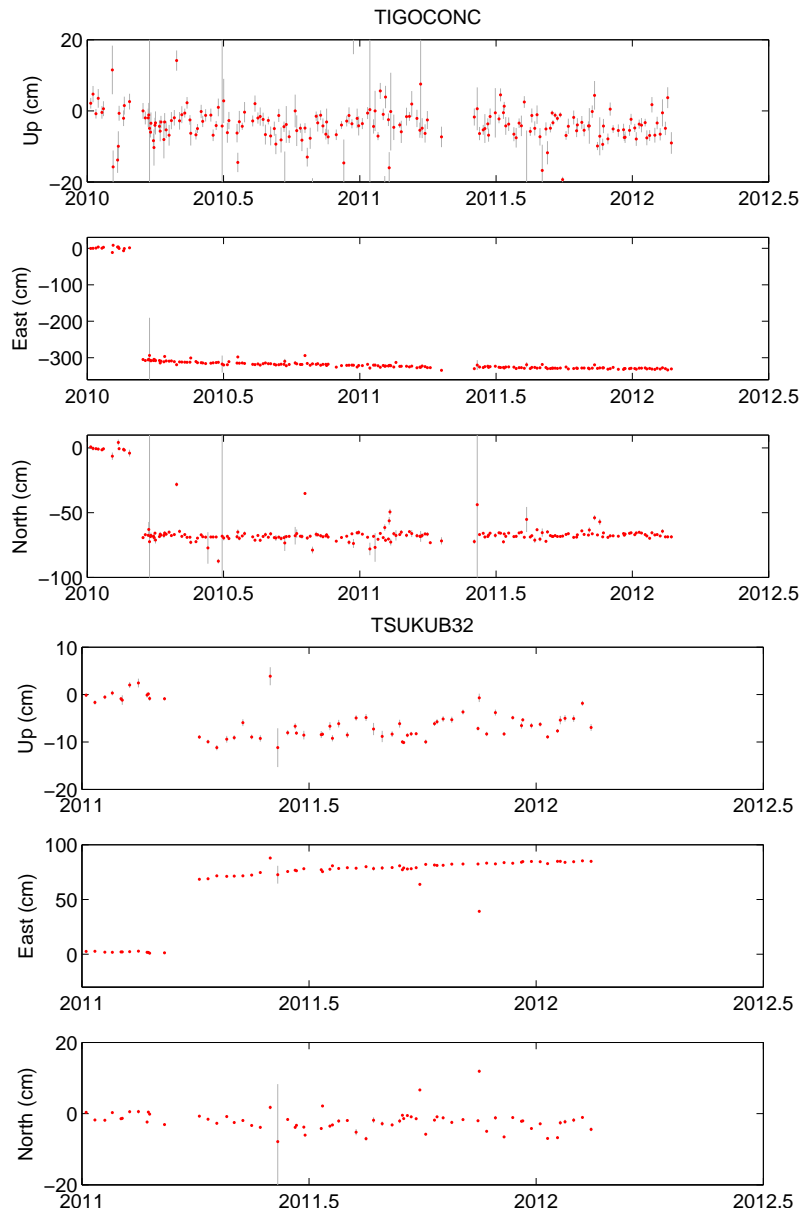

Figure 2. The UEN coordinates of TIGOCONC and TSUKUB32 antennas with respect to the VTRF 2008a solution.

# Onsala Space Observatory – IVS Analysis Center

*Rüdiger Haas, Tong Ning, Gunnar Elgered, Johan Löfgren, Hans-Georg Scherneck*

## Abstract

This report briefly summarizes the activities of the IVS Analysis Center at the Onsala Space Observatory during 2011 and gives examples of results of ongoing work.

## 1. Introduction

We concentrate on a number of research topics that are relevant for space geodesy and geosciences. These research topics are addressed in connection to data observed with geodetic VLBI and complementing techniques.

## 2. Assessment of Ultra-rapid dUT1-sessions

Since 2007, Onsala and Tsukuba have cooperated in a project to perform so-called ultra-rapid dUT1-sessions. For these sessions, real-time data transfer, near real-time correlation, and an automated near real-time data analysis allows the determination of dUT1 results with very low latency. In the beginning of the project, these sessions were dedicated Intensive-style sessions on one baseline for about 1 hour. Since 2009, normal 24-hour-long IVS sessions have also been observed in ultra-rapid mode. We performed a preliminary assessment of the dUT1 results derived in ultra-rapid mode [1]. The agreement between the ultra-rapid dUT1 results and the IERS final results is about 30 msec, i.e. approximately on the same level as the agreement between the IERS rapid results and the IERS final results. However, the ultra-rapid dUT1 results have a much lower latency and are, for example, available already during ongoing 24-hour IVS sessions.

## 3. Multi-technique Comparisons of Zenith Wet Delay Estimates

We compared 10-year-long time series of atmospheric zenith wet delay data [2]. These data were derived from VLBI, GPS, and ground-based radiometry at the Onsala Space Observatory, radiosondes from Landvetter airport, at a distance of about 37 km from Onsala, and the reanalysis product from the European Center for Medium-Range Weather Forecast. This comparison significantly extends previous work focussing on VLBI CONT-sessions only, see e.g. [3]. The best agreement over the 10 year period is seen between GPS and VLBI with a mean bias of  $-3.4$  mm and a standard deviation of 5.1 mm. The ECMWF product shows a positive bias of about 7 mm with respect to the other techniques.

## 4. Trends in the Amount of Integrated Atmospheric Water Vapor

We also compared long term trends in the amount of integrated atmospheric water vapor derived from four different techniques [4]. The four techniques are VLBI, GPS, ground-based radiometry at the Onsala Space Observatory, and radiosondes from Landvetter airport, at a distance of about 37 km from Onsala. The time series cover up to 30 years of data, and the four techniques detect individual positive trends in the integrated water vapor (IWV) on the order of 0.3 to 0.6

kg/m<sup>2</sup> per decade. The IWV data derived from the techniques agree with correlation coefficients on the order of 0.95 and better and root mean-square differences of less than 2 kg/m<sup>2</sup>.

## 5. Raytracing through the High Resolution Numerical Weather Model HIRLAM

We used the conformal theory of refraction to perform raytracing through data of the High Resolution Numerical Weather Model HIRLAM, and we computed slant delays for 15 European geodetic VLBI sessions between 2005 and 2007 [5]. Compared to our previous raytracing approaches, the new approach enables us to include atmospheric inhomogeneities.

## 6. Ocean Tides at Onsala

We used data recorded with the GNSS-based tide-gauge at Onsala [6] to determine ocean tidal constituents and compared these to theoretical models. The results indicate that the accuracy of global ocean models is restricted in the Skagerrak and Kattegat, and refined regional ocean tide models are necessary [7, 8].

## 7. Ocean Tide Loading

The automatic ocean tide loading provider [9] was maintained during 2011. Three new ocean tide models, DTU10 [10, 11] from the Danish University of Technology, EOT11a (which is an updated version of ET08a [12]) from DGFU Munich, and HAMTIDE [13] from the Institute of Oceanography at Hamburg University, were included.

## 8. VLBI Observations of GLONASS Satellite Signals

We continued to work on the analysis of VLBI observations of GLONASS satellite signals observed on the baseline Onsala – Medicina [14]. Fringes were successfully found with two different and independent software correlators.

## 9. Outlook

The IVS Analysis Center at the Onsala Space Observatory will continue its efforts to work on specific topics relevant to space geodesy and geosciences. During 2012 we plan to intensify our activities, in particular concerning VLBI data analysis.

## References

- [1] Haas R, Hobiger T, Sekido M, Koyama Y, Kondo T, Takiguchi H, Kurihara S, Kokado K, Tanimoto D, Nozawa K, Wagner J, Ritakari J, Mujunen A, Uunila M (2011) Near real-time monitoring of UT1 with geodetic VLBI. In: W. Alef, S. Bernhart, A. Nothnagel (eds.): *Proc. 20th Meeting of the European VLBI Group for Geodesy and Astrometry*, 64–66.
- [2] Ning T, Haas R, Elgered G, Willén U (2011) Multi-technique comparisons of 10 years of wet delay estimates on the west coast of Sweden. *Journal of Geodesy*, online published November 22, 2011, doi:10.1007/s00190-011-0527-2
- [3] Teke K, Böhm J., Nilsson T, Schuh H, Steigenberger P, Dach R, Heinkelmann R, Willis P, Haas R, Garcia-Espada S, Hobiger T, Ichikawa R, Shimizu S (2011) Multi-technique comparison of troposphere zenith delays and gradients during CONT08. *Journal of Geodesy*, **85**(7), 395–413, doi:10.1007/s00190-010-0434-y
- [4] Haas R, Ning T, Elgered G (2011) Long-Term Trends in the Amount of Atmospheric Water Vapour Derived From Space Geodetic and Remote Sensing Techniques. *ESA Proceedings WPP 326 : Proc. 3rd Int. Colloquium – Scientific and Fundamental Aspects of the Galileo Programme*
- [5] García-Espada S, Haas R, Colomer-Sanmartin F (2011) Application of ray-tracing through the high resolution numerical weather model HIRLAM applying the Conformal Theory of Refraction. In: W. Alef, S. Bernhart, A. Nothnagel (eds.): *Proc. 20th Meeting of the European VLBI Group for Geodesy and Astrometry*, 133–137.
- [6] Löfgren J, Haas R, Johansson J M (2011) Monitoring coastal sea level using reflected GNSS signals. *J. Advances in Space Research*, **47**(2), 213–229, doi:10.1016/j.asr.2010.08.015
- [7] Löfgren J, Haas R, Scherneck H-G (2011) Three months of local sea-level derived from reflected GNSS signals. *Radio Science*, **46**, (RS0C05), doi:10.1029/2011RS004693
- [8] Löfgren J, Haas R, Scherneck H-G (2011) Sea-Level Analysis Using 100 Days of Reflected GNSS Signals. *ESA Proceedings WPP 326 : Proc. 3rd Int. Colloquium – Scientific and Fundamental Aspects of the Galileo Programme*
- [9] Scherneck H.-G., Bos M. (2002) Ocean Tide and Atmospheric Loading. In: *IVS 2002 General Meeting Proceedings*, N.R. Vandenberg and K.D. Baver (eds.), **NASA/CP-2002-210002**, 205–214.
- [10] Andersen OB, Knudsen P (2009) The DNSC08 mean sea surface and mean dynamic topography. *J. Geophys. Res.*, **114**, C11, doi:10.1029/2008JC005179
- [11] Andersen OB (2010) The DTU10 Gravity field and Mean sea surface. *Second international symposium of the gravity field of the Earth (IGFS2)*, Fairbanks, Alaska.
- [12] Savcenko R, Bosch W (2008) EOT08a - empirical ocean tide model from multi-mission satellite altimetry. *DGFI Report 81*, Deutsches Geodätisches Forschungsinstitut (DGFI), München.
- [13] Taguchi E, Stammer D, Zahel W (2010) Estimation of deep ocean tidal energy dissipation based on the high-resolution data-assimilative HAMTIDE model. (to be submitted to *J. Geophys. Res.*).
- [14] Tornatore V, Haas R, Duev D, Pogrebenko S, Casey S, Molera-Calves G, Keimpema A (2011) Single baseline GLONASS observations with VLBI: data processing and first results. In: W. Alef, S. Bernhart, A. Nothnagel (eds.): *Proc. 20th Meeting of the European VLBI Group for Geodesy and Astrometry*, 162–165.

# PMD Analysis Center Report for 2011

*Vincenza Tornatore, Letizia Cannizzaro*

## Abstract

This report gives an overview of the “Politecnico di Milano” (PMD) VLBI Analysis Center activities during 2011 and briefly outlines the plans for 2012. The PMD AC processes IVS EUROPE sessions for baseline length variation computation and determination of time series coordinates of VLBI antennas. The AC performs also research and software development aimed to improve time series analysis. This work was developed within the context of comparison of VLBI and GPS (Global Positioning System) techniques and with respect to the geophysical models available in the European area. Another important task concerns the observational part; in particular several tests have been carried out to demonstrate the possibility of detecting GNSS satellite signals using the VLBI technique.

## 1. General Information

During 2011 the PMD AC did not significantly change its principal characteristics, e.g., the hardware and software components, location, sponsorship agency and staff described in the 2010 report. Three of the main fields of interest to PMD during 2011 are briefly highlighted in this report. They can be summarized here:

- Space co-location (VLBI—GNSS)
- Processing of EUROPE VLBI sessions
- Establishing procedures for VLBI and GPS time series analysis.

The current status of these activities, the principal results achieved, and foreseen further developments for next year are described in the following.

## 2. Space Co-location (VLBI—GNSS)

Many efforts dedicated to continue the observation activity of GNSS signals started already in 2009 [1]. International cooperation with other universities and research centers with similar interests was strongly supported. Thanks to the availability of different instruments, software, and interdisciplinary capabilities, several tests were performed to establish procedures for making possible the observation of GNSS signals with VLBI antennas. This is a very challenging task, since the use of the same optics (including gravitational and thermal deformations), electronics, and processing pipelines as for natural radio sources, observed with the VLBI technique, ensures the cross-calibration of two frames. GLONASS (GLObal NAVigation Satellite System) data observed during an experiment in 2010 with the Medicina and Onsala VLBI antennas were processed with two different correlation software packages, giving promising results; see [2] for more details on the experiment. The plans of PMD in this field are to continue with observing tests, using more than two stations, longer observing time intervals, and different designs that can foresee the use of natural calibrators near the satellite orbits for effectively reducing the contribution of uncalibrated errors in VLBI delay measurements such as station clock offsets, instrumental errors, and effects due to signal propagation in the ionosphere and the troposphere.

### 3. Processing of EUROPE VLBI Sessions

All the European sessions available since 1990 through the end of 2010 have been processed under the same modeling conditions and analogous parameterizations. The software used was VieVS (Vienna VLBI Software) [3] developed by the members of the VLBI group of the Institute of Geodesy and Geophysics (IGG), Vienna University of Technology (TU Wien) under the Matlab programming language. The configuration of the European geodetic VLBI network, that started with a core of six radio telescopes observing with an average of six sessions per year, reaches today a number of fourteen participating radio telescopes observing as regularly as possible with the same duty cycle. European site coordinates and baseline lengths with respective variance-covariance matrices have been estimated with VieVS to study their temporal evolution. The adjustments were performed both using single session and global approaches. Analyses of different solutions are in progress. In 2012, we plan to investigate in more detail the obtained results and to study also the influence of different datum definitions on European network parameter estimations.

### 4. Establishing Procedures for Time Series Analysis

In the framework of algorithm development for improving time series analysis of VLBI data and comparing them with GPS results, the goal was to develop tools that were common as much as possible to both techniques. Some members of the group working at the ‘Surveying Section’ of DIIAR gained a lot of experience on the Continuous GPS (CGPS) time series analysis field in the last years. This experience was considered as a starting point to develop/adapt such algorithms to VLBI time series analysis. It is well known that GPS solutions are daily or weekly solutions, generally quite regular for any GPS station; in contrast, VLBI solutions are usually carried out not as frequently. Then it often happens that, due to hardware or software problems at a VLBI station, this station will not take part in all the planned European sessions. In particular the work at PMD during 2011 was devoted to refining tools for CGPS coordinate time series analysis for geodynamic applications. In the last two decades the issues of CGPS time series analysis for geophysical applications were of great interest among the scientific community; different approaches have been developed, and several works have been published by different authors, e.g., [4], [5], [6]. The PMD DIIAR team faced the issue of GPS time series analysis in the context of the Seismic Information System for Monitoring and Alert Project (S.I.S.M.A. project) which was a three-year pilot project funded by the Italian Space Agency (ASI) starting in February 2007 [7], [8] with the aim to integrate Earth Observation data: SAR (Synthetic Aperture Radar) and GPS techniques and new advanced methods in seismological and geophysical data analysis for time-dependent seismic hazard assessment. The procedure implemented at PMD estimates a certain number of parameters by least squares adjustment. The most interesting parameters, from the geophysical point of view, are the velocity displacements and their errors. As scientific literature proved, the observations are temporally correlated and the adopted method estimates the proper deterministic and stochastic models. Here we briefly illustrate the analysis procedure that can be divided into five steps.

Step 1: removal of outliers and known discontinuities (see, e.g., Figure 1) due to

- technical equipment changes (e.g., GPS antennas/receivers)
- discontinuities due, e.g., to non-straight alignment of Reference Frame parameters

- co-seismic effect

Step 2: linear and periodic parameter estimations by least squares adjustment

Step 3: KPSS test [9] on residuals for assessment of stationary behavior

Step 4: study of coordinate time series correlations

- stationary residuals: estimate of the Empirical Covariance Function
- non-stationary residuals: simplified White Noise + Flicker Noise model [5]

Step 5: linear and periodic parameter re-estimations by least squares adjustment, applying the correct stochastic model.

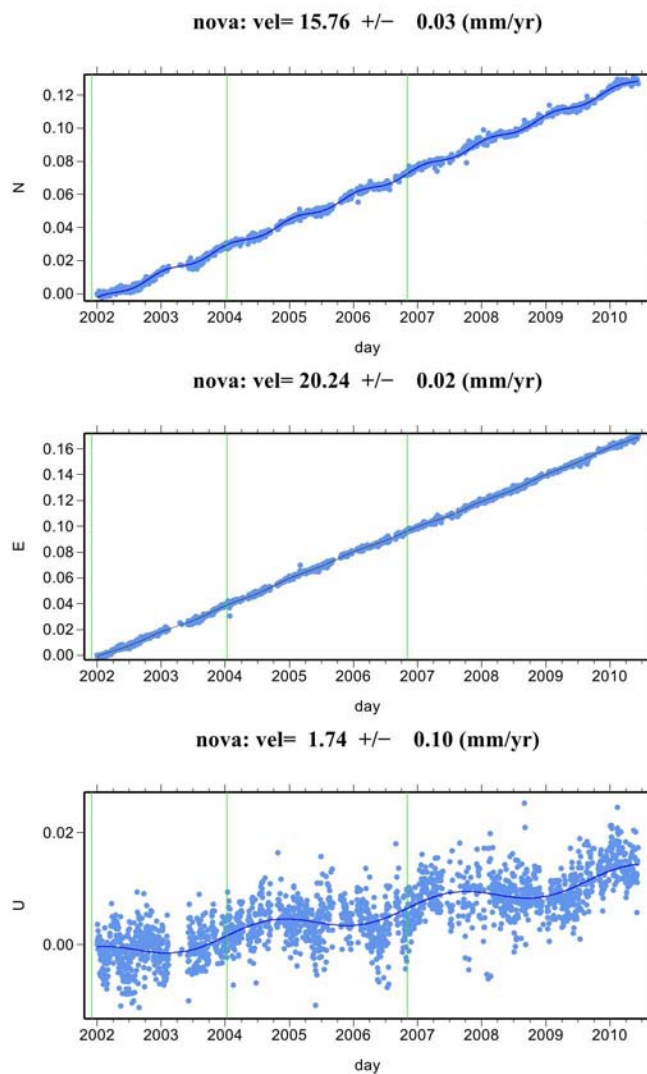

Figure 1. Coordinate time series for the GPS station of Novara.



The dots are North (mm), East (mm), and Up (mm) daily coordinate time series of the NOVA CGPS station (located in the town of Novara) and belonging to the Italian GPS fiducial network managed by the ASI – Italian Spatial Agency. Vertical lines represent the date of known discontinuities due to the Reference System and GPS antenna/receiver changes (the discontinuities have been removed in the figure). Continuous lines represent the final estimated deterministic models superimposed on the time series: the linear parameters stand for the velocity displacement of NOVA coordinate components.

The described procedure was applied to several Italian GPS stations. Due to the success of the method on GPS data which proved to have more reliable results, we plan for next year to adapt the developed algorithms from Fortran to the Matlab programming language and to VLBI time series studies. The final goal of such a task is to set up a statistical method common to both techniques, to reveal possible differences in estimated deformations of the European plate, and to compare the results with geophysical models.

## References

- [1] Tornatore V., Haas R., (2009), Considerations on the observation of GNSS-signals with the VLBI2010 system. In: G. Bourda, P. Charlot, A. Collioud (eds.): *Proc. 19th Meeting of the European VLBI Group for Geodesy and Astrometry* pp. 151-155.
- [2] Tornatore V., Haas R., Duev D., Pogrebenko S., Casey S., Molera-Calves G., Keimpema A., (2011) Single baseline GLONASS observations with VLBI: data processing and first results. In: W. Alef, S. Bernhart, A. Nothnagel (eds.): *Proc. 20th Meeting of the European VLBI Group for Geodesy and Astrometry*, 162–165.
- [3] Nilsson T., Boehm J., Boehm S., Madzak M., Nafisi V., Plank L., Spicakova H., Sun J., Tierno Ros J., Schuh H. (2011) Status and future plans for the Vienna VLBI Software VieVS, In: W. Alef, S. Bernhart, A. Nothnagel (eds.): *Proc. 20th Meeting of the European VLBI Group for Geodesy and Astrometry*, 93-96.
- [4] Nikolaidis R. (2002) Observation of Geodetic and Seismic Deformation with the Global Positioning System, PhD. Thesis, University of California, San Diego.
- [5] Williams SDP (2003) The effect of coloured noise on the uncertainties of rates estimated from geodetic time series, *Journal of Geodesy*, 76, pp. 483-494.
- [6] Amiri-Simkooei AR, Tiberius CCJM, Teunissen PJG (2007) Assessment of noise in GPS coordinate time series: Methodology and results, *Journal of Geophysical Research*, 112, B07413, pp. 19.
- [7] Barzaghi R., Borghi A., Cannizzaro L., Chersich M., Fermi M., Osmo M. (2009) Role of GPS data analysis in seismic hazard assessment in the frame of SISMA project, ENC-GNSS 2009, May 3-6, Naples, Italy.
- [8] Panza G.F., Peresan A., Magrin A., Sabadini R., Crippa B., Barzaghi R., Borghi A., Cannizzaro L., Amodio A., Zoffoli S. (2011) The SISMA prototype system: integrating Geophysical Modeling and Earth Observation for time dependent seismic hazard assessment, *Natural Hazards*, DOI: 10.1007/s11069-011-9981-7.
- [9] Hobijn B., Franses P.H., Ooms M., (2004) Generalization of the KPSS-test for stationarity, *Statistica Neerlandica*, 58, 4, 483-502.

# Pulkovo IVS Analysis Center (PUL) 2011 Annual Report

*Zinovy Malkin*

## Abstract

This report briefly presents the PUL IVS Analysis Center activities during 2011 and plans for the coming year. The main topics of the investigations of the PUL staff in that period were ICRF related studies, computation and analysis of EOP series, celestial pole offset (CPO) modelling, and VLBI2010 related issues.

## 1. General Information

The PUL IVS Analysis Center (AC) was organized in September 2006 and is located at and sponsored by the Pulkovo Observatory of the Russian Academy of Sciences. It is a part of the Pulkovo EOP and Reference Systems Analysis Center (PERSAC) [1]. The main topics of our IVS related activities are:

- Improvement of the International Celestial Reference Frame (ICRF).
- Computation and analysis of the Earth orientation parameters (EOP) from Intensives and 24-hour IVS sessions.
- Modelling of the celestial pole offset (CPO) and free core nutation (FCN).
- Comparison of VLBI products, primarily as Earth orientation parameters (EOP), with results of other space geodesy techniques.
- Computation and analysis of observation statistics.

The PUL AC's Web page [2] is supported. It contains the following sections:

- *General Information on the PUL AC.* Includes brief history, activity overview, and scientific staff list.
- *VLBI data analysis.* Includes results of VLBI data analysis, such as CPO/FCN series, UT1 Intensives series, and mean Pole coordinates. Data are updated daily.
- *OCARS catalog.* Includes the latest version of the catalog of optical characteristics of astrometric radio sources (OCARS) [3]. The catalog is continually updated as new information becomes available.
- *Approaches and occultations.* Includes tables for forthcoming mutual events of planets and astrometric radio sources, such as close angular approaches and occultations for the period until 2050 [4].
- *PUL members' publications and presentations.*
- *VLBI technology overview.*
- *Links to the VLBI World.* Includes links to (primarily geodetic and astrometric) VLBI coordinating bodies, stations, analysis centers, software, etc.
- *Contact information.*

## 2. Scientific Staff

In 2011 the following persons contributed to the PUL activity:

1. Zinovy Malkin (70%) — PUL coordinator, EOP and CRF analysis
2. Natalia Miller (10%) — EOP analysis
3. Julia Sokolova (10%) — CRF analysis

## 3. Activities and Results

The main activities and results of the PUL IVS Analysis Center during 2011 included:

- Operational processing of the IVS Intensive sessions in automated mode and submission of results to IVS was continued.
- ICRF related research was continued. The main directions of this activity were comparison and combination of radio source catalogs, and investigation of their stochastic and systematic errors.
- The work on the OCARS catalog [3] was continued. The current basic statistics of the catalog is the following:

	OCARS	ICRF2	ICRF2 def.
Sources	6431	3414	295
Sources with known redshift	3167 (49.2%)	2072 (60.7%)	253 (85.8%)
Sources with known optical magnitude	4132 (64.3%)	2541 (74.4%)	284 (96.3%)

- A catalog of approaches of planets to radio sources and occultations of astrometric radio sources by planets through the year 2050 was updated [4].
- Investigations of CPO modelling and its impact on data processing were continued. The main activities and results in 2011 are the following:
  - The PUL CPO and FCN series are updated daily.
  - The results of comparing the CPO and FCN models were published [5]. In this paper, several publicly available empirical models of the celestial pole offset (CPO) and free core nutation (FCN), including those developed by the author, were investigated and compared to each other from different points of view, such as representation of the observational data, FCN parameter variation, and prediction accuracy. Based on this study, some practical recommendations were proposed.
  - The impact of celestial pole offset modelling on VLBI UT1 Intensive results was studied [6]. In this study, three CPO models currently available for users were tested and the differences between UT1 estimates obtained with those models were investigated. It was shown that neglecting CPO modelling during VLBI UT1 Intensive processing causes systematic errors in UT1 series of up to 20  $\mu$ as. It was also found that using different CPO models causes differences in UT1 estimates reaching 10  $\mu$ as. The obtained results are applicable to the satellite data processing as well.

- A preliminary study of the impact of the Galactic aberration on VLBI-derived precession parameters has begun [7]. It has been shown by comparison of the linear trends in the coordinates of the celestial pole obtained with and without taking into account the Galactic aberration that this effect can reach  $20 \mu\text{as}/\text{cy}$ . It is also shown that correcting for the Galactic aberration influences the derived parameters of low-frequency nutation terms. It is therefore necessary to correct for Galactic aberration in the reduction of modern astrometric observations.
- The PUL archive of VLBI data and products is supported. At present, all available databases and corresponding NGS cards for 1979 – 2011 have been stored (about 9.4 million observations) along with the main IVS and IERS products. These archives are continually updated as new databases become available.
- The development of algorithms and software for data processing and analysis was continued.
- PUL staff members participated in the activities of several IERS, IAG, and IVS projects, committees, and working groups.

#### 4. Outlook

Plans for the coming year include:

- Continue VLBI related studies.
- Continue UT1 Intensive processing.
- Continue OCARS catalog support.
- Continue development of algorithms and software for data processing.
- Continue support of the PUL archives of data and products.

#### References

- [1] <http://www.gao.spb.ru/english/as/persac/index.htm>
- [2] [http://www.gao.spb.ru/english/as/ac\\_vlbi/](http://www.gao.spb.ru/english/as/ac_vlbi/)
- [3] [http://www.gao.spb.ru/english/as/ac\\_vlbi/ocars.txt](http://www.gao.spb.ru/english/as/ac_vlbi/ocars.txt)
- [4] [http://www.gao.spb.ru/english/as/ac\\_vlbi/occultations\\_approaches.pdf](http://www.gao.spb.ru/english/as/ac_vlbi/occultations_approaches.pdf)
- [5] Malkin Z. M. Comparison of CPO and FCN empirical models. In: Proc. Journees 2010: New challenges for reference systems and numerical standards in astronomy, Paris, France, 20-22 Sep 2010, ed. N. Capitaine, Paris, 2011, pp. 172–175
- [6] Malkin Z. The impact of celestial pole offset modelling on VLBI UT1 intensive results. *J. of Geodesy*, 2011, v. 85, No. 9, 617-622. DOI 10.1007/s00190-011-0468-9
- [7] Malkin Z. M. The Influence of Galactic Aberration on Precession Parameters Determined from VLBI Observations. *Astronomy Reports*, 2011, Vol. 55, No. 9, 810–815. DOI: 10.1134/S1063772911090058

# SAI VLBI Analysis Center Report 2011

*Vladimir Zharov*

## Abstract

This report presents an overview of the SAI VLBI Analysis Center activities during 2011 and the plans for 2012. The AC SAI analyzes all IVS sessions for computations of the Earth orientation parameters (EOP), time series of source positions at the scope of new realizations of the ICRF, and performs research and software development aimed at improving the VLBI technique.

## 1. General Information

The SAI VLBI Analysis Center is located at Sternberg State Astronomical Institute of Lomonosov Moscow State University in Moscow, Russia. The Analysis Center participates in geodetic and astrometric VLBI analysis, software development, and research aimed at improving the VLBI technique.

## 2. Component Description

AC SAI performs data processing of all kinds of VLBI observation sessions. For VLBI data analysis we use the ARIADNA software package developed at SAI. All reductions are performed in agreement with the IERS Conventions (2003). A new version of the package is being developed that will use the IERS Conventions (2010).

ARIADNA uses files in NGS format as input data.

The latest version named as ORBITA is used on the correlator of the AstroSpace Center in support of the Radioastron mission.

## 3. Staff

- Vladimir Zharov, Prof.: development of the ARIADNA software, development of the methods of parameter estimation.
- Aleksander Akosta, post-graduate student: development of the ORBITA software, analysis of the Radioastron data
- Dmitry Duev, post-graduate student: VLBI data processing, troposphere modeling
- Nikolay Voronkov, scientific researcher: global solution
- Svetlana Nosova, engineer: VLBI data processing

## 4. Current Status and Activities

### • Software development for VLBI processing

The ARIADNA software is being developed to provide contributions to IVS products. The software is used for calculating all types of IVS products.

The latest version of the software called ORBITA is used for solving many tasks during the Radioastron mission: calculation of delay and delay rate for the ground-space interferometer,

orbit determination of the space telescope by numerical integration of the differential equations of motion and use of Doppler tracking, laser ranging and VLBI observations for improvement of the Radioastron orbit on the basis of the Kalman filter. The report about the first successful detection of the interference fringes – a correlated signal on ground-to-space baselines can be found online ([http://www.asc.rssi.ru/radioastron/news/newsl/en/newsl\\_10\\_en.pdf](http://www.asc.rssi.ru/radioastron/news/newsl/en/newsl_10_en.pdf)).

The successful detection of interference fringes demonstrates the overall adequacy of the technique used in the ORBITA software.

- **Routine analysis**

During 2011 the routine data processing was performed with the ARIADNA software using the least-squares method with rigid constraints. A new approach with non-rigid constraints will be developed for the generation of SINEX files too.

AC SAI operationally processed the 24-hour and Intensive VLBI sessions. The formation of databases for the VLBI sessions and processing of all sessions is fully automated. The EOP series `sai2011a.eops` and `sai2011a.eopi` were calculated. These series were computed with the catalog VTRF2008 of station positions and velocities.

- **Global solution**

N. Voronkov developed software to obtain a global solution. The radio source coordinates and velocities and the station coordinates and velocities were estimated as global parameters. EOP, troposphere wet zenith delay (approximated as a polynomial function), troposphere gradients, and station clocks (approximated as a polynomial function) were estimated as arc parameters for each session. An experimental catalog of the radio source positions and velocities was obtained.

- **Troposphere modeling**

At the stations with the meteorological data missing we used surface data files (temporal coverage: four-times daily, spatial coverage: 2.5 degrees latitude x 2.5 degrees longitude global grid) from NCEP/NCAR Reanalyses (<http://www.cdc.noaa.gov/data/gridded/data.ncep.reanalysis.surface.html>) for calculating air temperature, pressure, and relative humidity. For that purpose a program was written, which interpolates these data to the given coordinates of the station at the time of the observations.

A test version of the software was developed to use the troposphere zenith delay from the GNSS service in the VLBI analysis.

## 5. Future Plans

- Continue investigations of VLBI estimation of EOP, station coordinates, and troposphere parameters, and comparison with satellite techniques.
- Development and testing of the version of ARIADNA in which all reductions are performed according to the IERS Conventions (2010).
- Improvement of the ARIADNA software for processing of the GNSS troposphere zenith delays.

# SHAO Analysis Center 2011 Annual Report

Guangli Wang, Jinling Li, Minghui Xu, Li Guo, Fengchun Shu, Zhihan Qian, Liang Li

## Abstract

This report presents the activities of the Shanghai Astronomical Observatory (SHAO) Analysis Center in 2011. The SHAO Analysis Center performs data processing and analysis of the geodetic experiments of the Chinese VLBI Network (CVN), analyzes all of the IVS 24h sessions, and submits the analysis products (EOP, TRF, and CRF) to the IVS regularly. We have carried out research work on estimation of Solar acceleration and the consistency analysis of the UT1 time series from IVS Intensive sessions.

## 1. General Information

We are in charge of the data processing and analysis of the CVN experiments and analyzing the IVS data using the CALC/SOLVE software. The members involved in the IVS analysis activities are Guangli Wang, Jinling Li, Minghui Xu, Li Guo, Liang Li, Fengchun Shu, and Zhihan Qian.

## 2. Activities in 2011

### 2.1. Data Processing and Analysis of the CVN Geodetic Experiments

Since the year 2009, China has carried out the Project of Crustal Monitoring Network of the Chinese Mainland Geological Environment (CMNOC). In this project, the CVN carries out more than eight 24-hour experiments per year. SHAO undertakes the operations of CVN and data analysis.

The CVN started to conduct astrometric and geodetic VLBI experiments in 2006. But regular observations did not take place before 2010. Table 1 shows the statistical information about the CVN experiments.

The SHAO Analysis Center is in charge of the routine analysis of the CVN data, including:

- Calculation of the delay and delay rate of the CVN observations at each band, resolving group delay ambiguities, and computation of ionosphere calibrations utilizing the post-correlator software *pps*, which is developed based on software made especially for the post-correlation in the Chang'E Program.
- Generation of the VLBI group delay in the NGS format using the software *gngs*.
- Analysis of all CVN sessions using software *shops*, which is developed based on the software *OCCAM6.1E(Linux)* with modifications mainly in VLBI data processing models.

### 2.2. Regular Data Analysis of the IVS 24h Sessions and Product Submission

We restarted routinely analyzing all IVS 24h sessions using the CALC/SOLVE software, and in this year we also regularly submitted our analysis products (EOP, TRF, and CRF) to the IVS Data Centers.

Table 1. The statistical information of the CVN experiments.

Experiment Code	Date	Duration (hr)	Stations	Obs. Number	Delay wrms (ps)
s6602	20060601	10	ShBjKmUr	171	30.3
r7404a	20070404	24	ShBjKmUr	1561	57.3
r7620a	20070620	24	ShBjKmUr	479	32.7
r8919a	20080901	24	ShBjKmUr	282	36.1
g1003d	20100602	24	ShKmUr	545	65.8
g1004a	20100720	24	ShKmUr	368	48.5
g1005a	20100810	24	ShKmUr	414	64.5
r0902a	20100902	24	ShBjKmUr	1590	46.0
r1117a	20110117	24	ShBjKmUr	2534	34.3
r1325a	20110325	24	ShBjKmUr	1598	54.0
r1425a	20110425	23	ShBjKmUr	902	55.7
r1524a	20110524	24	ShKmUr	1136	44.4
t2078	20110720	24	ShKmUr	641	112
r1b14a	20111114	24	ShKmUr	1302	100.1
r1b28a	20111128	24	ShBjKmUr	–	–

Table 2. Statistical information of the results from the different INT1 types.

Year	1984 - 1994	1994 - 2000	2000 - 2011
Stations	Wetzell Westford	Wetzell Green Bank	Wetzell Kokee Park
Number of sessions	1854	1359	2374
Length of baseline (km)	5998	6724	10357
East-West-dimension (km)	5977	6669	10072
Avg. number of scans per session	9.6	17.2	20.9
Avg. normal error of $\Delta$ UT1 ( $\mu$ s)	124.6	26.2	11.7
Avg. offset w.r.t. C04/precision ( $\mu$ s)	-14.1 / 2.4	14.0 / 1.7	10.4 / 0.5
Standard derivation w.r.t. C04 ( $\mu$ s)	101.8	61.8	25.6

Table 3. Comparison of the results from the different Intensive types.

	Avg. number of scans per session	Avg. normal error ( $\mu$ s)	Avg. offset / precision w.r.t. C04 ( $\mu$ s)	Standard deviation w.r.t. C04 ( $\mu$ s)
INT1	20.9	11.7	10.4 / 0.5	25.6
INT2	29.7	10.3	10.3 / 0.9	21.4
INT3	70.2	8.6	31.0 / 2.8	28.3



### 2.3. Analysis of UT1 Determined from IVS Intensive Observations

We carried out an analysis of the IVS Intensive data from 1984.02 to 2011.08 with different observation networks, INT1, INT2 and INT3, and we discussed the progress of the UT1 accuracy. By comparing UT1 results from different networks, we have found a difference on the order of dozens of microseconds between the networks. The results from the IVS Intensive observations in which the Seshan station observed showed a similar performance to that of other stations. From the comparison and analysis of different UT1 series, there exists a level of  $10 \mu\text{s}$  uncertainty between UT1 estimations obtained from the IVS Intensive observations and from the IERS C04. The results are presented in Table 2 and Table 3.

### 2.4. Estimation of Solar Acceleration

The secular aberration drift observed as the apparent proper motion of extragalactic radio sources is caused by the acceleration of the coordinate origin, the Solar system barycenter. For 30 years, this effect will accumulate up to about  $200 \mu\text{as}$ , which is far beyond the declared several tens of  $\mu\text{as}$ -level of the ICRF2 accuracy. We estimated the acceleration as a global parameter by using the 30 years of global geodetic/astrometric VLBI data. This estimation is independent of any kinematic or dynamic model of the Milky Way or statistics hypothesis. The estimated acceleration in the direction of the Galactic center is  $0.75 \pm 0.05 \text{ cm}\cdot\text{s}^{-1}\cdot\text{yr}^{-1}$ , while the other two components are  $-0.02 \pm 0.06$  and  $0.40 \pm 0.05 \text{ cm}\cdot\text{s}^{-1}\cdot\text{yr}^{-1}$  in the direction along the Solar motion in the Galactic plane and in the direction normal to the Galactic plane, respectively.

## 3. Plans for 2012

We will continue to submit our analysis products to the IVS Data Centers regularly. In order to submit the CVN observations to the IVS, we will conduct the work of transferring the data format of CVN observations from NGS to netcdf. The research activities will focus on the ICRF with the consideration of the secular aberration and the study of the high frequency variations of EOP.

# Tsukuba VLBI Analysis Center

*Kensuke Kokado, Shinobu Kurihara, Ryoji Kawabata, Kentaro Nozawa*

## Abstract

The aim of activities at Tsukuba VLBI Analysis Center is to examine the VLBI data processing and analysis method to obtain EOP values within the shortest possible time after the VLBI observing session. The most successful result in 2011 was an ultra-rapid dUT1 measurement during the CONT11 session, which is a campaign of 15 days of continuous VLBI sessions. In this article, the improved data processing/analysis system and the results of our analysis activities are reported.

## 1. General Information

The Tsukuba VLBI Analysis Center is located at the Geospatial Information Authority of Japan (GSI). We became an IVS Operational Analysis Center on April 7, 2010 and started to submit an ultra-rapid dUT1 solution of IVS-INT2 sessions to IVS in January 2011. The rapid solution has been used for the calculation of USNO EOP daily solutions. We have also implemented the ultra-rapid dUT1 experiments during IVS 24-hour sessions in cooperation with the National Institute of Information and Communications Technology (NICT) and Onsala Space Observatory (OSO) in Sweden since 2007. These experiments were a good opportunity to improve the data processing/analysis program for ultra-rapid dUT1 measurement. In 2011, most of the experiments succeeded, and we could obtain dUT1 solutions during the 24-hour observing sessions.

## 2. Data Processing and Analysis System for Ultra-rapid Measurement

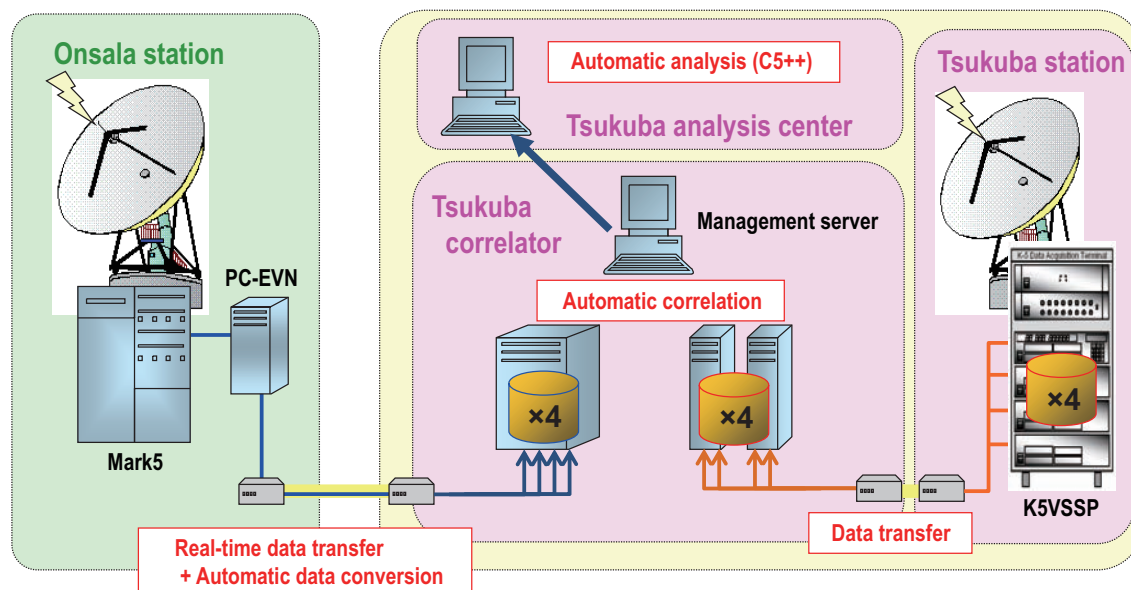

Figure 1. Ultra-rapid dUT1 measurement system.

The data processing system for the ultra-rapid dUT1 measurement is shown in Figure 1. The data of the foreign observatories, such as Wettzell, Onsala, or Hobart, is transferred in real-time

during the observation. The data from the Onsala or the Hobart station are converted to K5/VSSP format after the data transfer because the format of the transferred data is Mark 5B. On the other hand, the format of the transferred data from Wettzell is VDIF, and it is converted to K5/VSSP format with a real-time data transfer system developed by NICT at the same time of recording on a data server at Tsukuba correlator. It enables us to reduce the latency of VLBI sessions.

The converted data is correlated as soon as the data conversion is completed. We use about 16 servers for the correlation process, and the processes are completed within a few minutes after the observing session. When the correlation results for all of the data, or enough data for dUT1 analysis, are ready, the analysis program “c5++” developed by NICT runs automatically, and we can obtain a dUT1 solution within five minutes after the observing session. All of the programs run automatically, so we do not have to type any commands during the session. If any error occurs during data processing, the programs send any error e-mail messages to the operators. We used the data processing system for ultra-rapid dUT1 measurement on IVS-INT2 sessions, some of the 24-hour sessions, and CONT11 sessions.

### 3. Results of Our Activities

The Tsukuba VLBI Analysis Center implements three different kinds of ultra-rapid dUT1 measurements. This section shows the results of these dUT1 measurements.

#### 3.1. Ultra-rapid dUT1 Measurement in INT2 Sessions

The Tsukuba VLBI Analysis Center has implemented the ultra-rapid dUT1 measurement in INT2 sessions in 2009 and started to provide the solution “eopi” file to the IVS Data Center at the end of January, 2011. All of the solutions were analyzed by c5++, and results were provided within seven hours after the observing sessions. It is possible to provide the dUT1 solution within a few minutes after the observing sessions on the Tsukuba-Wettzell baseline session, but it is not possible to provide the solution so quickly for the sessions with the Kokee-Wettzell baseline, because the data from the Kokee station are not transferred in real-time. As the data transfer is completed about six hours after the session, the submission of the dUT1 solution is about seven hours after the observing session on the Tsukuba-Wettzell baseline. The automated data transfer or the data analysis program sometimes stopped due to some kinds of error, so we could not submit the dUT1 solution the same day in about 30% of the sessions. We try to solve the problem of this program every time the ultra-rapid dUT1 measurement fails.

#### 3.2. Ultra-rapid dUT1 Measurement in IVS 24-hour Sessions

In 2011, we also implemented the ultra-rapid dUT1 measurement in 18 IVS 24-hour sessions (e.g., R1, RD, and T2) in which the Tsukuba, Onsala, Wettzell, or Hobart station participated. In the case of 24-hour sessions, we can obtain a number of dUT1 values during the observing session because the data analysis is done every several tens of scans. We sometimes failed in the data transfer process from the Onsala station but succeeded in ultra-rapid dUT1 measurement in most of the sessions. Most of the failure is due to human error, so we may have to make a check sheet or automated check program for the preparation of data transfer.

The new approach in 2011 was that we implemented the ultra-rapid EOP experiment with the Onsala and Hobart stations. We processed the data of North-South baselines for estimating X/Y

parameters of polar motion and East-West baselines for dUT1 measurement. We implemented the experiment in the RD1106 session and an additional session named “UREO01” at the end of November. Although we had some problems with the data transfer, all of the data processing was completed within 24 hours after the observing session. We plan to improve the system and want to process all of the data without any problem with the next experiment. The solution of dUT1 and X/Y parameters of polar motion estimated from the UREO01 session are shown in Figures 2, 3, and 4.

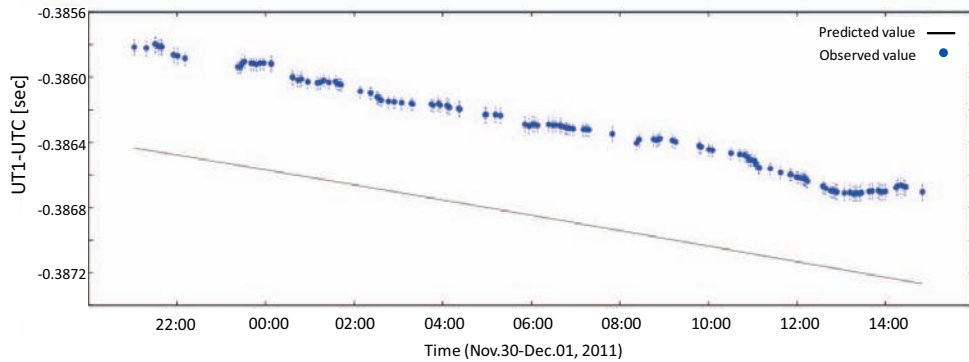

Figure 2. dUT1 values estimated from the “UREO01” session.

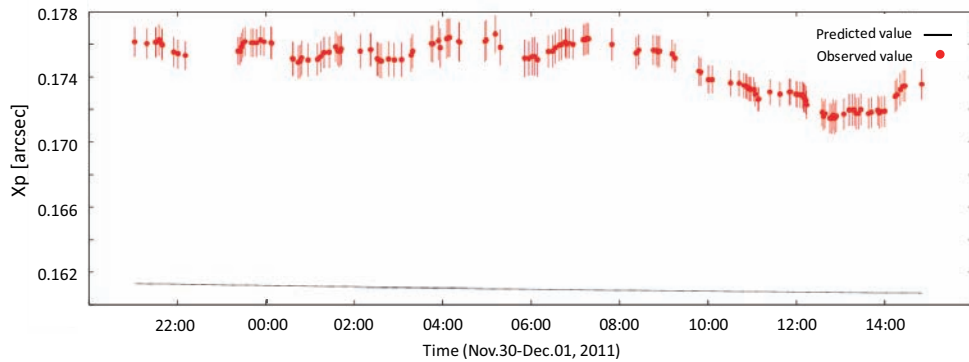

Figure 3. X-parameter of polar motion estimated from the “UREO01” session.

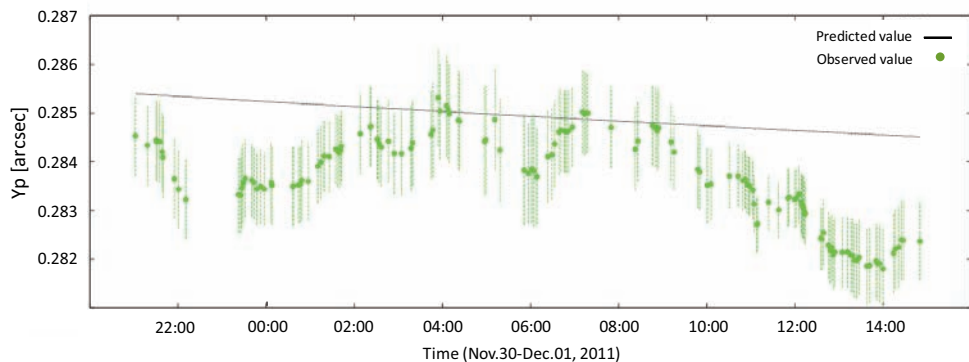

Figure 4. Y-parameter of polar motion estimated from the “UREO01” session.

### 3.3. Ultra-rapid dUT1 Measurement in the CONT11 Session

The ultra-rapid dUT1 measurement during the CONT11 campaign was performed on the Tsukuba-Onsala baseline. The data was transferred to the Tsukuba correlator, correlated, and analyzed in near real-time during the session. As CONT11 was a campaign of 15 days of continuous VLBI sessions, we could obtain continuous dUT1 values for 15 days about 30 minutes after the observation of each scan. Unfortunately, we were forced to stop the ultra-rapid dUT1 measurement for about one day from September 21 to September 22, because the Tsukuba station was affected by a big typhoon. We failed in data transfer from Onsala and could not analyze the data for about three hours on September 25 and 26, but we succeeded in the ultra-rapid dUT1 measurement for most of the scans of CONT11. The estimated dUT1 values are shown in Figures 5 and 6.

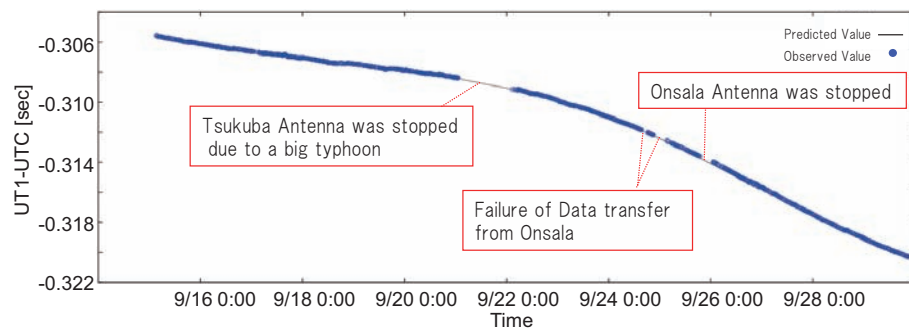

Figure 5. dUT1 values of the ultra-rapid dUT1 experiment during CONT11.

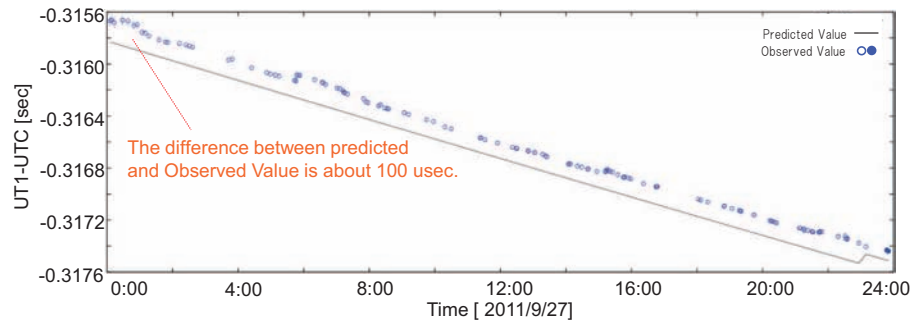

Figure 6. dUT1 values of the ultra-rapid dUT1 experiment on September 27.

## 4. Staff

- Kensuke Kokado (GSI): Correlation Chief, Management of overall activity
- Kentaro Nozawa (AES): Main operator of the analysis work

## 5. Plan for 2012

We will continuously implement an ultra-rapid dUT1 or EOP measurement with selected IVS 24-hour sessions and try to submit the rapid solutions to the IVS data center. In addition, we plan to analyze the data to determine the optimum analysis method for each 24-hour session.

## U.S. Naval Observatory VLBI Analysis Center

*David A. Boboltz, Alan L. Fey, Nicole Geiger, Kerry A. Kingham, David M. Hall*

### Abstract

This report summarizes the activities of the VLBI Analysis Center at the United States Naval Observatory for calendar year 2011. Over the course of the year, Analysis Center personnel continued analysis and timely submission of IVS-R4 databases for distribution to the IVS. During the 2011 calendar year, the USNO VLBI Analysis Center produced one periodic global solution designated usn2011a. Earth orientation parameters (EOP), based on this solution and updated by the latest diurnal (IVS-R1 and IVS-R4) experiments, were routinely submitted to the IVS. Sinex files based upon the bi-weekly 24-hr experiments were also submitted to the IVS.

During the 2011 calendar year, Analysis Center personnel focused much of their efforts on both the DiFX software correlator implementation at USNO and on implementing a program of daily Intensive sessions to measure UT1–UTC using two stations of the Very Long Baseline Array (VLBA) operated by the National Radio Astronomy Observatory (NRAO). High-speed network connections were established to the Mauna Kea, HI and Pie Town, NM stations for the purpose of electronically transferring the data back to USNO for correlation and analysis.

## 1. Introduction

The USNO VLBI Analysis Center is supported and operated by the United States Naval Observatory (USNO) in Washington, DC. The primary services provided by the Analysis Center are the analysis of diurnal experiments, the production of periodic global Terrestrial Reference Frame (TRF) and Celestial Reference Frame (CRF) solutions, and the submission to the IVS of Intensive (EOP-I) and session-based (EOP-S) Earth orientation parameters based on USNO global TRF solutions. Analysis Center personnel maintain the necessary software required to continue these services to the IVS including periodic updates of the GSFC CALC/SOLVE software package. In addition to operational VLBI analysis, Analysis Center personnel are actively engaged in research related to future reference frames, the electronic transfer of VLBI data, and software correlation.

## 2. Current Analysis Center Activities

### 2.1. IVS Experiment Analysis and Database Submission

During the 2011 calendar year, personnel at the USNO VLBI Analysis Center continued to be responsible for the timely analysis of the IVS-R4 experiments, with the resulting databases submitted within 24 hours of correlation for dissemination by the IVS. Analysis Center personnel continue to be responsible for the analysis and database submission for the periodic IVS-CRF experiments. In 2011, USNO scheduled and analyzed 11 CRF related experiments including IVS-CRF62 through IVS-CRF66 and IVS-CRDS50 through IVS-CRDS55. The analyzed databases were submitted to the IVS. Analysis Center personnel also continued analyzing IVS Intensive experiments for use in the USN-EOPI time series.

## 2.2. Global TRF Solutions, EOP, and Sinex Submission

USNO VLBI Analysis Center personnel continued to produce periodic global EOP/TRF solutions over the course of the 2011 calendar year. This year a single solution (usn2011a) was produced and submitted to the IVS. Analysis Center personnel continued to submit the USN-EOPS series, which are now based upon the 2011a solution and are updated with new IVS-R1/R4 experiments. The updated EOPS series was submitted to the IVS twice weekly within 24 hours of experiment correlation and is included in the IERS Bulletin A. Analysis Center personnel also continued routine submission of Sinex format files based upon the 24-hr VLBI sessions. In addition to EOPS and Sinex series, USNO VLBI Analysis Center personnel continued to produce and submit an EOPI series based upon the IVS Intensive experiments.

## 2.3. Celestial Reference Frame (CRF)

During the 2011 calendar year, Analysis Center personnel continued work on the production of global CRF solutions. In 2011, a single solution (crf2011a) was produced for local use within USNO. The global CRF solutions produced are routinely compared to the current ICRF (ICRF2).

## 2.4. Software Correlator

Over the course of the 2011 calendar year, Analysis Center personnel continued the implementation, testing, and evaluation of the DiFX software correlator. The software correlator implementation at USNO currently consists of four nodes (workstations) with a total of 28 processing cores and two Mark 5 data playback units. The correlator nodes and Mark 5 units are connected through a 1 Gbps ethernet switch. Since April 2011, Analysis Center personnel have been regularly correlating one IVS-INT1 (Kk-Wz) Intensive session per week on the software correlator in parallel with the WACO hardware correlator. In addition, the post-correlation calibration path has been fully exercised with the DiFX output converted to traditional Mark IV-style correlator output using the difx2mark4 software developed at Haystack Observatory. The Mark IV output has been fringe-fitted and calibrated within FOURFIT/HOPS, and geodetic databases have been produced using DBEDIT.

Analysis Center personnel continue to interface with colleagues from various institutions within the DiFX consortium, and they attended the DiFX meetings in Bonn, Germany (March 2011) and at Haystack Observatory in Westford, MA (December 2011). To facilitate the smooth transition to the software correlator and to expand USNO's involvement in the DiFX consortium, a software engineer (Dr. John Spitzak) was hired to work on the development of a graphical user interface (GUI) for DiFX.

## 2.5. VLBA Intensive Experiments

Over the course of the 2011 calendar year, Analysis Center personnel made considerable progress with regard to the implementation of a new Intensive series using two stations of the VLBA. USNO contracted with NRAO and the University of Hawaii to install and maintain 1Gbps fiber links to the stations at Pie Town, NM and Mauna Kea, HI. These fiber links were in service on March 1, 2011 for PT and on July 15, 2011 for MK. In addition, both stations were outfitted with the network infrastructure and new Mark 5C units necessary to record the data and e-transfer it back to USNO. Both fiber links have been tested, and data have been transmitted at speeds up

to 400 Mbps from each station back to USNO via the links.

A series of test observations began in September 2011 using the upgraded MK and PT stations. The wide-band tests were conducted using the newly available digital backends with sixteen 32 MHz wide channels at a data rate of 2 Gbps. Intensives run for 40 minutes with approximately 12 seconds per scan on source resulting in roughly 30 – 35 scans per session. The 12-second scan length allows the data size to be  $\sim 100$  GB per station per session, which makes for more manageable e-transfers. From the start, the VLBA Intensive tests have been correlated on the DiFX software correlator. Mark IV style output is generated using the difx2mark4 software, and the data are fringe-fitted using FOURFIT/HOPS. Geodetic-style databases are generated with DBEDIT and analyzed within SOLVE. The analyzed databases have been put into a SOLVE batch solution along with the other Intensive sessions for comparison. Figure 1 shows the differences between the VLBA MK-PT baseline UT1–UTC results and IERS C04 from October 2011 through January 2012. Differences between IERS C04 and the USN-EOPI and USN-EOPS series are also shown for comparison.

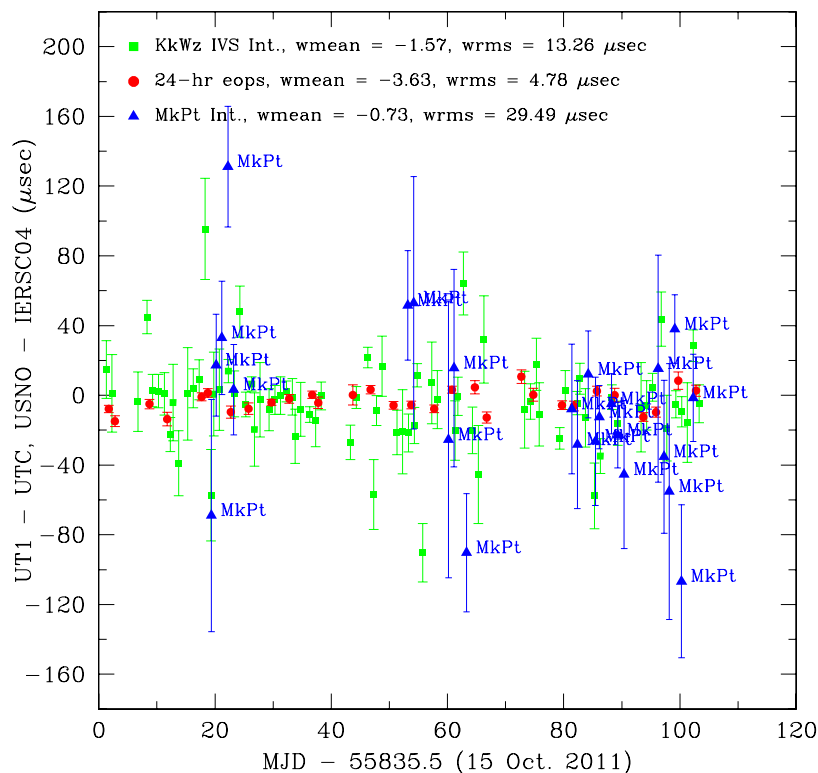

Figure 1. Differences in UT1-UTC between data from the VLBA Intensive test sessions using the MK-PT baseline and IERS C04. Also shown are differences between IERS C04 and both the USN-EOPI and USN-EOPS standard series for comparison. Error bars are  $1\sigma$  formal uncertainties.

The plan is for these sessions to become operational in the summer of 2012. Once fully operational, they will be scheduled as IVS-INT4 Intensive sessions, and data will be released to the IVS



for community-wide distribution.

### 3. Staff

The staff of the VLBI Analysis Center is drawn from individuals in both the Astrometry and Earth Orientation departments at the U.S. Naval Observatory. The staff and their responsibilities are as follows:

<b>Name</b>	<b>Responsibilities</b>
David Boboltz	VLBA Intensive program; software correlator implementation; VLBI data analysis.
Alan Fey	Periodic global CRF/TRF/EOP solutions and comparisons; CRF densification research; software correlator implementation; VLBI data analysis.
Nicole Geiger	software correlator implementation; VLBI data analysis; EOP, database and Sinex submission.
Kerry Kingham	Hardware correlator interface; software correlator implementation; VLBI data analysis.
David Hall	Hardware correlator interface; software correlator implementation; VLBI data analysis.

### 4. Future Activities

For the upcoming year, January 2012 – December 2012, USNO VLBI Analysis Center personnel plan to accomplish the following activities:

- Continue testing and evaluation of the USNO implementation of the DiFX software correlator. Streamline pre- and post-correlation processing.
- Procure a new software correlator system to replace the current WACO hardware correlator.
- Continue testing the electronic transfer of VLBI Intensive data from the MK and PT VLBA stations with regular operations beginning summer 2012.
- Continue analysis and submission of IVS-R4 experiments for dissemination by the IVS.
- Continue the production of periodic global TRF solutions and the submission of EOP-S estimates to the IVS updated by the IVS-R1/R4 experiments.
- Continue submission of Sinex format files based on the 24-hr experiments and begin production of a Sinex series based upon the Intensive experiments.
- Continue the analysis of Intensive experiments and submission of EOP-I estimates to the IVS.
- Continue the scheduling, analysis, and database submission for IVS-CRF and IVS-CRDS experiments.
- Continue the production of periodic global CRF solutions.

# USNO Analysis Center for Source Structure Report

*Alan L. Fey, David A. Boboltz, Ralph A. Gaume, Kerry A. Kingham*

## Abstract

This report summarizes the activities of the United States Naval Observatory Analysis Center for Source Structure for calendar year 2011 and the activities planned for the year 2012.

## 1. Analysis Center Operation

The Analysis Center for Source Structure is supported and operated by the United States Naval Observatory (USNO). The charter of the Analysis Center is to provide products directly related to the IVS determination of the “definition and maintenance of the celestial reference frame”. These include, primarily, radio frequency images of International Celestial Reference Frame (ICRF) sources, intrinsic structure models derived from the radio images, and an assessment of the astrometric quality of the ICRF sources based on their intrinsic structure.

The Web server for the Analysis Center is hosted by the USNO and can be accessed by pointing your browser to

[http://rorf.usno.navy.mil/ivs\\_saac/](http://rorf.usno.navy.mil/ivs_saac/)

The primary service of the Analysis Center is the Radio Reference Frame Image Database (RRFID), a Web accessible database of radio frequency images of ICRF sources. The RRFID contains 7,279 Very Long Baseline Array (VLBA) images of 782 sources at radio frequencies of 2.3 GHz and 8.4 GHz. Additionally, the RRFID contains 1,706 images of 282 sources at frequencies of 24 GHz and 43 GHz. The RRFID can be accessed from the Analysis Center Web page or directly at

<http://rorf.usno.navy.mil/rrfid.shtml>

The RRFID also contains 74 images of 69 Southern Hemisphere ICRF sources using the Australian Long Baseline Array (LBA) at a radio frequency of 8.4 GHz.

Images of ICRF sources can also be obtained from the Bordeaux VLBI Image Database (BVID) at

<http://www.obs.u-bordeaux1.fr/m2a/BVID/>

## 2. Current Activities

Maintaining the Radio Reference Frame Image Database (RRFID) as a Web accessible database of radio frequency images of ICRF sources.

## 3. Staff

The staff of the Analysis Center is drawn from individuals who work at the USNO. The staff are: Alan L. Fey, David A. Boboltz, Ralph A. Gaume, and Kerry A. Kingham.

#### 4. Future Activities

The Analysis Center currently has a program of active research investigating the effects of intrinsic source structure on astrometric position determination. Results from this program are published in the scientific literature.

The following activities for 2012 are planned:

- Continue imaging and analysis of VLBA 2.3/8.4/24/43 GHz experiments.
- Maintain the Radio Reference Frame Image Database (RRFID) as a Web accessible database of radio frequency images of ICRF sources.

#### 5. Relevant Publications

Publications of relevance to Analysis Center activities:

- “TANAMI: tracking active galactic nuclei with austral milliarcsecond interferometry. I. First-epoch 8.4 GHz images,” Ojha, R., Kadler, M., Böck, M., Booth, R., Dutka, M. S., Edwards, P. G., Fey, A. L., Fuhrmann, L., Gaume, R. A., Hase, H., Horiuchi, S., Jauncey, D. L., Johnston, K. J., Katz, U., Lister, M., Lovell, J. E. J., Müller, C., Plötz, C., Quick, J. F. H., Ros, E., Taylor, G. B., Thompson, D. J., Tingay, S. J., Tosti, G., Tzioumis, A. K., Wilms, J. and Zensus, J. A. 2010, *A&A*, 519, 45
- “The Celestial Reference Frame at 24 and 43 GHz. I. Astrometry,” Lanyi, G. E., Boboltz, D. A., Charlot, P., Fey, A. L., Fomalont, E. B., Geldzahler, B. J., Gordon, D., Jacobs, C. S., Ma, C., Naudet, C. J., Romney, J. D., Sovers, O. J. and Zhang, L. D. 2010, *AJ*, 139, 1695
- “The Celestial Reference Frame at 24 and 43 GHz. II. Imaging,” Charlot, P., Boboltz, D. A., Fey, A. L., Fomalont, E. B., Geldzahler, B. J., Gordon, D., Jacobs, C. S., Lanyi, G. E., Ma, C., Naudet, C. J., Romney, J. D., Sovers, O. J. and Zhang, L. D. 2010, *AJ*, 139, 1713



# Technology Development Centers

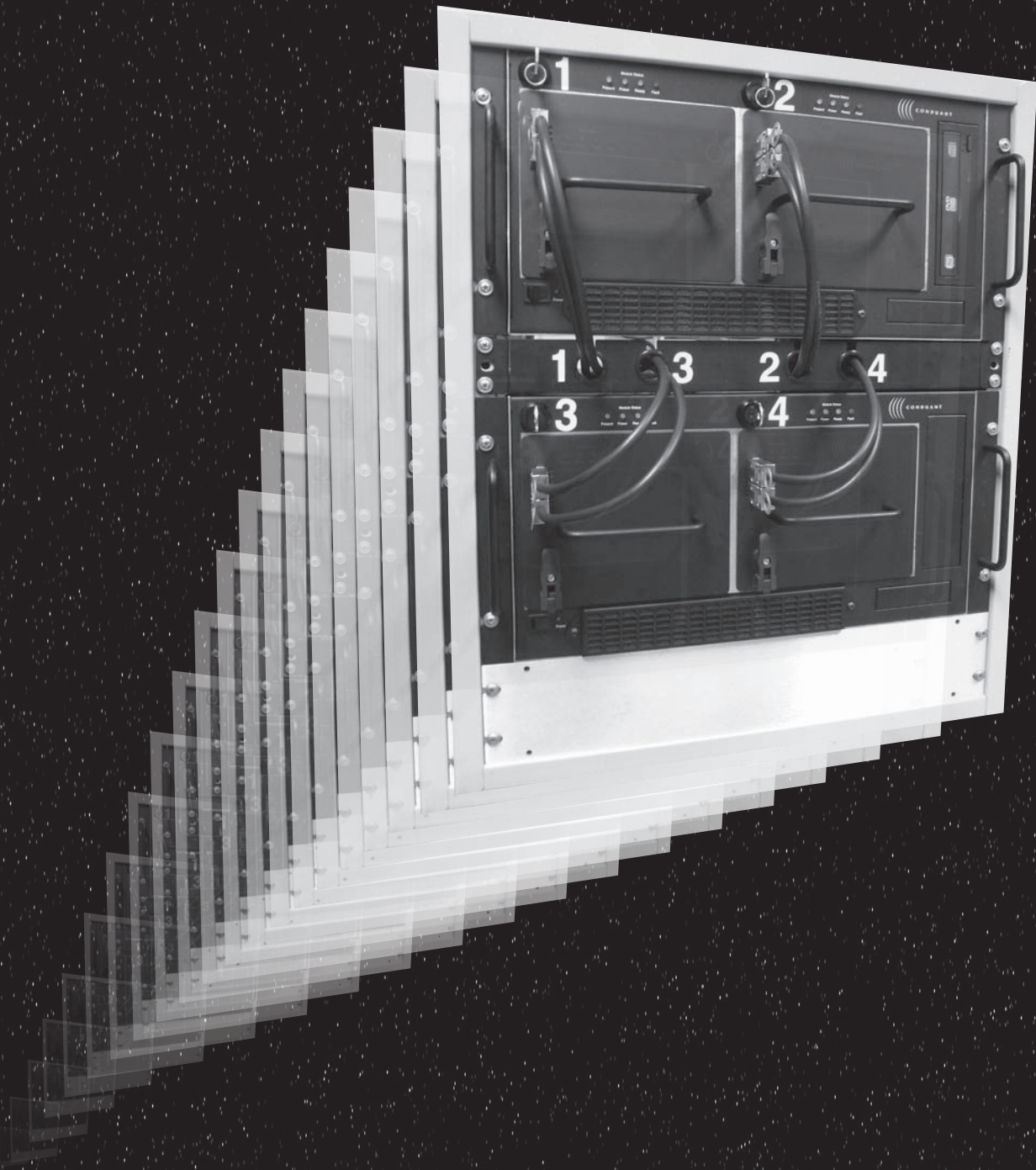

**Technology Development Centers**



# Canadian VLBI Technology Development Center

*Bill Petrachenko*

## Abstract

The Canadian VLBI Technology Development Center (TDC) is involved in activities related to the realization of VLBI2010.

## 1. Introduction

The Canadian TDC is a collaborative effort of the National partners interested in the advancement of VLBI technology, namely the Geodetic Survey Division of Natural Resources Canada (GSD/NRCan) and the Dominion Radio Astrophysical Observatory (DRAO) of the Herzberg Institute for Astrophysics of the National Research Council of Canada (DRAO/HIA/NRC).

## 2. VLBI2010 Committee (V2C)

The Canadian TDC is primarily focused on encouraging the realization of VLBI2010. This is done by Bill Petrachenko of NRCan, who is chairman of the V2C. In collaboration with others, this year's activity focused on the following areas.

- Development of algorithms for processing broadband data.
- Development of FPGA algorithms for VLBI2010 digital back ends.
- Development of specifications for VLBI2010 sub-systems.
- Execution of studies into the nature, impact, and mitigation of Radio Frequency Interference (RFI)
- Development of strategies for the mitigation of the impact of source structure.
- Participation in the VLBI2010 Project Executive Group.

## 3. DRAO Activities

Under the leadership of Gordon Lacy, designs are complete and fabrication plans in place for a 15-m off-axis Gregorian top-fed composite antenna that is light, stiff, efficient, and cost effective.

Under the leadership of Brent Carlson, correlator development at DRAO is focused on novel designs for the SKA.

Development also progresses in the areas of focal plane arrays and a general purpose high-capacity multi-FPGA signal processing platform.

# FFI Technology Development Center - Software Development

*Per Helge Andersen*

## Abstract

This report discusses the current status of the FFI Technical Development Center as well as upcoming changes.

## 1. Status and Future Changes

FFI is currently an Associate Analysis Center for IVS and ILRS, and a Technology Development Center for IVS. The Norwegian Mapping Authority (NMA) and FFI have a close cooperation in the analysis of space geodetic data using the GEOSAT software. NMA has recently been given the status of an Associate Analysis Center of IVS (28 October 2010). The plan is that NMA will apply to become a Technology Development Center for IVS and that FFI will end this formal role in 2012. The GEOSAT TD and AC activities at both institutions will be coordinated by NMA. This also implies that FFI will stop being an IVS Associate Analysis Center in 2012.

## 2. The GEOSAT Software and Activities in 2011

FFI's contribution to the IVS as a Technology Development Center focuses primarily on the development and validation of the GEOSAT software for a combined analysis at the observation level of data from VLBI, GPS (ground-based and LEO), SLR, DORIS, altimetry, accelerometry, and GRACE KBR. The advantages of the combination of independent and complementary space geodetic data at the observation level is discussed in Andersen [1].

Space borne accelerometry has been implemented, and a small set of data has been tested (GOCE and GRACE). Software to convert space-based gravity models and accelerometry / gradiometry data to geoid information is being implemented right now. A complete production line for altimetry (Topex, ENVISAT, JASON 1 and 2) has been implemented and tested. Map animations of sea level rise have been developed, so far based on GDR-orbits. Software for the analysis of cross-over data is being developed right now. In the near future the altimeter analyses will be based on orbits determined with GEOSAT instead of the GDR-orbits, to be more consistent with the TRF realized with GEOSAT. The cross-over software can be used for quality evaluation of the GDR and GEOSAT orbits.

The GEOSAT orbit model has been validated against external LEO orbits. The RMS difference between JPL GRACE orbits and internal GEOSAT orbits is typically 4 mm in each Cartesian direction. The corresponding RMS difference between external GOCE orbits (ESA official, approximately 250 km altitude) and internal GEOSAT orbits is typically 11 mm. This work will continue in 2012.

A lot of work has been done to improve the consistency between VLBI results from GEOSAT and results from the other IVS Analysis Centers.

- The VMF1 model for tropospheric refraction has been implemented.
- A LSQ-module quite similar to GSFC SOLVE, including continuous linear spline parameter representations, has been implemented and tested. The plan is however to use the UD-filter



estimator available in GEOSAT for the production of SINEX files. The LSQ estimator was implemented for the purpose of data editing and as an external check of the filter solutions.

- A misinterpretation of the NGS-format has been corrected, giving more consistent estimates of UT1-UTC.
- A number of options have been implemented for the detection and correction of clock breaks, for the suppression of one or more individual stations, for manual detection and rejection of individual outlier observations, and for validating the results.

NMA has now taken over a version of VLBI/GEOSAT with these improvements, and a production line for the routine generation of normal equations for IVS combination will be established in the near future. There are now options in GEOSAT so that the VLBI model is in compliance with the other VLBI analysis software packages.

### 3. Staff

Dr. Per Helge Andersen - Research Professor of Forsvarets forskningsinstitutt (FFI and NMA).  
Dr. Eirik Mysen - Research geodesist at the Norwegian Mapping Authority (NMA).  
Dr. Kristian Breili - Research geodesist at the Norwegian Mapping Authority (NMA).  
Dr. Halfdan Kierulf - Research geodesist at the Norwegian Mapping Authority (NMA).  
Dr. Oddgeir Kristiansen - Section Manager at the Norwegian Mapping Authority (NMA).

### References

- [1] Andersen, P. H. Multi-level arc combination with stochastic parameters. *Journal of Geodesy* (2000) 74: 531-551.

# GSFC Technology Development Center Report

*Ed Himwich, John Gipson*

## Abstract

This report summarizes the activities of the GSFC Technology Development Center (TDC) for 2011 and forecasts planned activities for 2012. The GSFC TDC develops station software including the Field System (FS), scheduling software (SKED), hardware including tools for station timing and meteorology, scheduling algorithms, and operational procedures. It provides a pool of individuals to assist with station implementation, check-out, upgrades, and training.

## 1. Technology Center Activities

The GSFC IVS Technology Development Center (TDC) develops hardware, software, algorithms, and operational procedures. It provides manpower for station visits for training and upgrades. Other technology development areas at GSFC are covered by other IVS components such as the GSFC Analysis Center. The current staff of the GSFC TDC consists of John Gipson and Ed Himwich, both employed by NVI, Inc. The remainder of this report covers the status of the main areas supported by the TDC.

## 2. Field System

The GSFC TDC is responsible for development, maintenance, and documentation of the Field System (FS) software package. The FS provides equipment control at VLBI stations. It interprets the .snp schedule and .prc procedure files (both as prepared by DRUDG from the .skd schedule). The FS controls the antenna, data acquisition hardware, and related ancillary equipment needed for making VLBI measurements. All major VLBI data acquisition backends are supported. The FS is customizable to allow it to control station specific equipment. It is used at all the IVS Network Stations (i.e., more than 30) and also at many stations that do VLBI only for astronomical observations. The only major VLBI facilities not using it are the VLBA and VERA.

There were no new releases of the FS during this period. However, several development projects were underway:

- **Patriot 12-m Interface.** A preliminary interface to Patriot 12-m antennas was developed. This was implemented using the position and velocity tracking mode in the Patriot antenna controller. All aspects of this appear to work, but final testing is delayed until next year when the antenna controller and receiver will be more nearly in their final configuration.
- **Satellite Tracking.** A satellite tracking capability was developed for the FS. This will allow an antenna to be pointed at a satellite in one of three modes: (1) Ephemeris, (2) Az-El, or (3) RA-Dec. The Ephemeris tracking mode is the most flexible and precise. A one second ephemeris for several hours is built in memory, which the *antcn* antenna interface can use to guide the antenna. However, this requires special programming of the antenna interface, and some antennas may not be able to support this mode. The Az-El mode is useful for geo-synchronous or possibly slowly moving satellites, if the antenna being used supports commanding with fixed Az-El coordinates. The RA-Dec mode is the most universal since all antennas support RA-Dec pointing, but it may have limited usefulness if the satellite is not

moving at a nearly sidereal rate. It is expected that the Az-El and RA-Dec modes will be enhanced to allow periodic recommanding of the position. This may help with tracking slow moving objects. However, depending on the behavior of the antenna, this may introduce unacceptable jumps in the antenna tracking. The open source *predict* program is used to calculate the pointing angles from the orbital elements.

- Holography. A new SNAP command **holog** was developed to support holographic measurements of antennas. In its simplest form, this command will move an antenna in a boustrophedon pattern around a grid centered on either an Az-El or RA-Dec commanded position. A user-defined SNAP procedure is run to collect data at each grid point. Various options are available including specifying a “return to center” interval for recalibration, changing the order in which the grid points are visited, and allowing single “cuts” to be made on each axis.

These new capabilities will be included in FS releases next year. Several other improvements are expected in future releases, including:

- Support for DBBC and RDBE racks
- Support for Mark 5C recorders
- Use of *idl2rpc* for remote operation
- A complete update to the documentation and conversion to a more modern format that will be easier to use
- Conversion of the FORTRAN source to use the *gfortran* compiler; this will enable use of the source level debugger, *gdb*, for development and field debugging
- *Chekr* support for Mark 5A and Mark 5B systems
- Use of the Mark IV Decoder for phase-cal extraction in the field
- FS Linux 9 (based on Debian *squeeze*) distribution
- Support for periodic firing of the noise diode during observations
- Distribution of the new *gnplt*.

### 3. SKED and DRUDG

The GSFC TDC is responsible for the development, maintenance, and documentation of SKED and DRUDG. These two programs are very closely related, and they operate as a pair for the preparation of the detailed observing schedule for a VLBI session and its proper execution in the field. In the normal data flow for geodetic schedules, first SKED is run at the Operation Centers to generate the *.skd* file that contains the full network observing schedule. Then stations use the *.skd* file as input to DRUDG for making the control files and procedures for their station. Catalogs are used to define the equipment, stations, sources, and observing modes which are selected when writing a schedule with SKED.

Changes to SKED and DRUDG are driven by changes in equipment and by feedback from the users. The following summarizes some of the important changes to these programs in 2011 and plans for 2012.

### 3.1. SKED

The only changes made to SKED this year were bug fixes and minor enhancements. The following is a list of bug fixes:

- Fixed a problem with writing out the lower sideband in VEX files.
- Fixed an issue in writing schedule files if the fan-out mode varied from station to station.
- Fixed a bug in **tag-along** mode that affects the calculation of slewing time. Previously the slewing time started from the last time the antenna was used. However, if the last time a station observed was a long time ago, the calculation was not accurate and could lead to problems with cable wrap.
- Made the list of valid correlators consistent with the list in the VLBI master files.

Following is a list of minor enhancements:

- Added the parameter **MaxAngle** which specifies the maximum distance to move.
- Added the command **NOW <time>** which sets the time of all stations to the current time. This was done to aid in the scheduling of CONT11.
- Increased the number of **downtimes** from 20 to 2000. CONT11 required around 450.

In addition we continued working on updating the SKED documentation. The last time the documentation was revised was in 1996. We expect to finish this project in 2012.

### 3.2. DRUDG

No changes were made to drudg during 2011.

### 3.3. Plans for Next Year

Plans for next year include:

- Releasing the new SKED documentation;
- Making VEX the native format for SKED and DRUDG
- Better source modeling
- Modifying SKED and DRUDG as necessary to support VLBI2010.

# Haystack Observatory Technology Development Center

*Chris Beaudoin, Brian Corey, Arthur Niell, Alan Whitney*

## Abstract

Technology development at MIT Haystack Observatory was focused on four areas in 2011: 1) Development of VLBI2010 receiver hardware, 2) Digital Backend development, 3) RFI compatibility at GGOS stations, and 4) Mark 6 VLBI Data System development.

## 1. Development of VLBI2010 Receiver Hardware

In 2011 Haystack Observatory was engaged in the development of a second receiver frontend for the new GGAO Cobham 12-m antenna as well as for the Westford antenna. Both receivers are based on the Caltech-designed/built QRFH shown in Figure 1 and the CRYO1-12 low-noise amplifiers, also developed at Caltech. The geometric design of these two feeds is quite different; the GGAO 12-m QRFH is circular [1] while the Westford QRFH is square. The difference in the geometric design is attributed to the difference in the Westford and GGAO 12-m reflector optical configurations; the GGAO 12-m requires a feed beamwidth of  $100^\circ$  while Westford requires a feed having  $160^\circ$  beamwidth.

Prior to installing the QRFH-based frontend on the GGAO 12-m antenna, Y-factor measurements of the frontend were conducted; these measurements demonstrated 30K noise temperature over 2-12 GHz. After installing the QRFH-based receiver on the GGAO 12-m, the broadband SEFD of the receiver was estimated from on-source/off-source total power measurements of Tau-rus A. Initially, the SEFD performance was poorer than expected due, it was discovered, to a misalignment of the subreflector. Repeated SEFD measurements were utilized to fine tune the position of the subreflector, and peak sensitivity was achieved when the subreflector was 15.9 mm further from the vertex than the original position. After re-aligning the subreflector, the receiver temperature was estimated by the Y-factor method, and the SEFD was immediately re-measured. Given the radio telescope's SEFD and system temperature, the aperture efficiency of the telescope was computed. Figure 2 shows the broadband aperture efficiency of the radio telescope as estimated from the measurements collected on day 249. The theoretically expected aperture efficiency of the 12-m radio telescope under illumination by its QRFH was computed by William Imbriale (JPL) using a custom physical-optics solver; Figure 2 shows this expectation as well. Given that the solution does not incorporate blockage losses from the support struts and subreflector, the agreement shown in Figure 2 is considered to be quite reasonable. The expected efficiency loss due to the supporting structure is under investigation.

Figure 2 also shows the system temperature of the complete receiver system, from frontend to backend in the control room, as measured on days 249 and 336. As can be seen, the system temperature on the first day increases significantly at higher frequencies. It was subsequently discovered that this was due to an unspecified increase in the noise figure of the microwave-over-fiber link. Additional gain, preceding the fiber link, was introduced to overcome the high frequency noise figure (at the expense of less saturation overhead) and led to the substantial improvement in receiver system temperature as shown in Figure 2 for day 336. Given the aperture efficiency reported in Figure 2 and the improvements in system temperature (day 336), the SEFD over the 3-12 GHz band is expected to be below 2500 Jy, which is the VLBI2010 goal. The fiber link was also

being driven into saturation by strong S-band RFI at GGAO. For this reason, a 3.9 GHz highpass pre-link filter was installed in the receiver; hence the system temperatures shown in Figure 2 are limited to 3 GHz on the low end of the spectrum. Until the GGAO receiver can accommodate S-band observing, it will not be fully compliant with VLBI2010 specifications. This is a topic of current investigation.

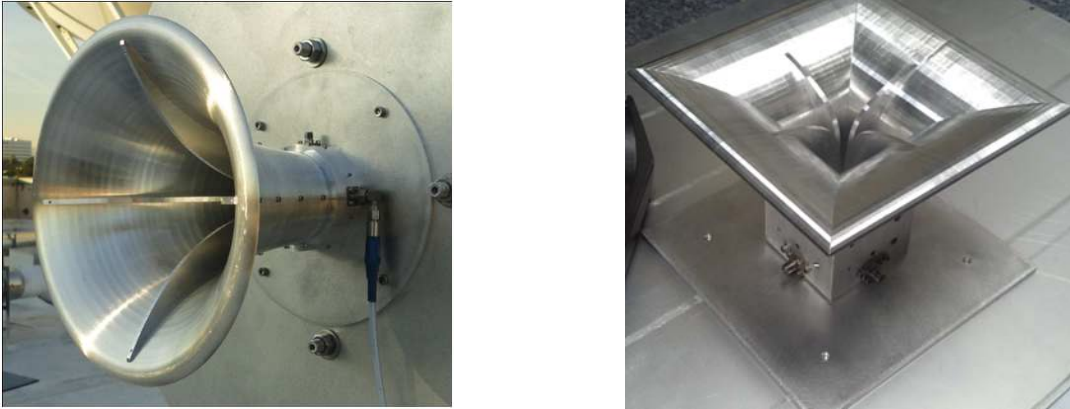

Figure 1. Broadband microwave feeds for NASA broadband receivers: (left) GGAO 12-m QRFH feed, (right) Westford 18-m QRFH feed.

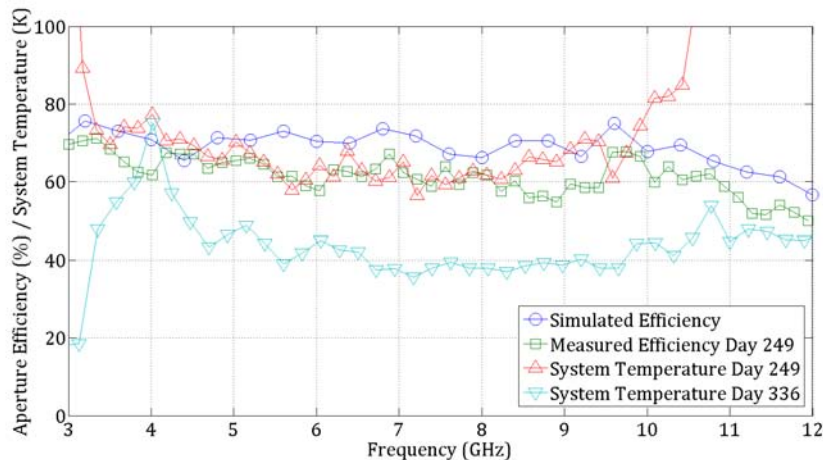

Figure 2. Simulated and measured (on day 249) aperture efficiencies of the GGAO 12-m under illumination by the QRFH. Also shown is the measured system temperature of the GGAO 12-m receiver on days 249 and 336 of year 2011, before and after the introduction of additional pre-fiber gain, respectively. Strong 4 GHz RFI was present on day 336.

## 2. Digital Backend Development

In the past year collaborations between Haystack and NRAO have continued to further the development of the RDBE subsystem. In 2011 the RDBE geodetic polyphase filter bank (PFB)

personality bitcode version 1.4 was officially released, and RDBEs can now be ordered through DigiCom<sup>1</sup> for new station construction and current station upgrades. The RDBE provides 16 user-selectable 32 MHz channels from a choice of 16 uniformly-spaced channels in each of the 512 MHz IF inputs. Initially, a PFB personality providing 8 MHz channels was also planned for development for compatibility with operational S/X observations. However, a development in the DiFX correlator now supports the correlation of channels of differing bandwidth, provided there is common spectral overlap in the channels. This feature of the DiFX software provides the final missing link required to allow RDBE backends to co-observe with stations incorporating legacy baseband converters.

### 3. RFI Compatibility at GGOS Stations

Haystack Observatory has been involved in studies of the compatibility of DORIS and the SLR aircraft radar with the VLBI2010 receiver since these two active techniques pose a potential to degrade VLBI data quality and, in the worst case, damage the frontend of the VLBI receiver at a fundamental GGOS station. To support this effort, X-band power level measurements of the SLR aircraft tracking radars at GGAO were conducted to verify the expected radiation properties of these systems. The results of this study have been reported in [2].

As described in [2] GGAO operates two SLR systems, NGSLR and Moblas7, both of which employ aircraft-tracking radars. To avoid potential damage to the 12-m frontend electronics, both SLR systems and the 12-m system now have programmed pointing masks to exclude observations within 30 degrees of the other technique. These masks are not intended to avoid degradation of broadband VLBI data; such masks would be prohibitively large and would severely impact operations [3]. For this reason, Haystack is involved in an electromagnetic-barrier study, the goal of which is to reduce the pointing restrictions on the unshielded radar and VLBI systems. The DORIS transmitter at GGAO does not pose a threat of damaging the electronics of the 12-m receiver.

### 4. Mark 6 Data System Development

The demand for greater VLBI observation sensitivity continues to push required data-acquisition and playback rates to higher and higher levels. The current Mark 5 generation of data systems tops out at sustained 4 Gbps per system. However, near-term demands are for 8 Gbps, pushing to sustained recording and playback at 16 Gbps within about a year. These rates are required to support the 1-mm global measurement precision demanded by the VLBI2010 system.

In order to meet these needs, Haystack Observatory, in collaboration with the High-End Network Computing Group at NASA/GSFC, has embarked on the design of a 16-Gbps VLBI data system. Unlike its Mark 5 predecessor, the Mark 6 system is based entirely on commercial-off-the-shelf hardware. The only exception is the continued use of customized 8-disk modules which are similar to the disk modules used in the Mark 5 system and which provide the necessary portability demanded by the geodetic VLBI application. We are partnering with Conduant Corporation of Longmont, CO, who also partnered with Haystack on the Mark 5 system, for development of specific items to support the custom Mark 6 disk modules, and who will also act as the manufacturer

---

<sup>1</sup>Digicom Electronics, Inc. info@digicom.org

and distributor of Mark 6 systems for the global VLBI community.

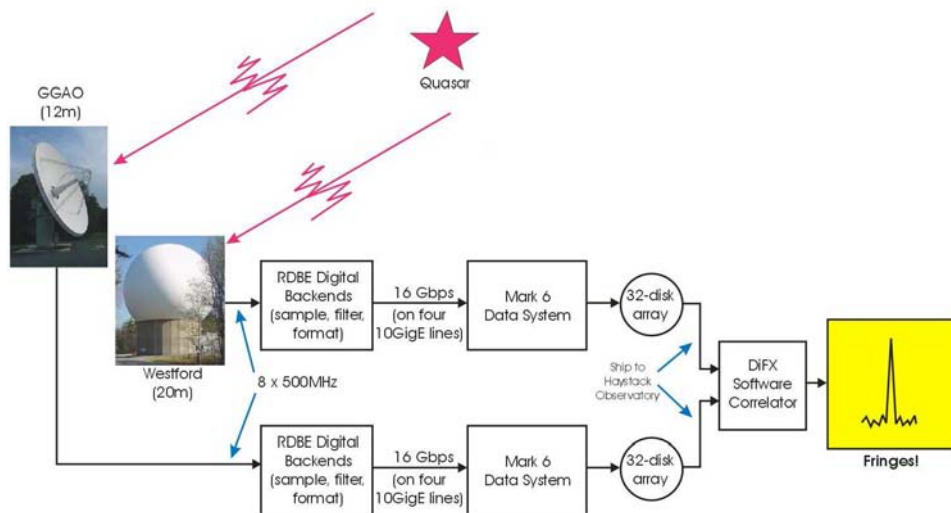

Figure 3. Diagram of the experimental setup for the 16 Gbps Mark 6 demonstration.

The cost of the Mark 6 system will be lower than that of the Mark 5 system, but the data-rate capability will be four times greater. This will help to significantly reduce the cost of supporting the new demand for higher data rates. The Mark 6 system is expected to be available for operational use in the latter half of 2012.

In late October 2011, early Mark 6 prototype systems were used in a VLBI demonstration experiment between the Westford 18-m and GGAO 12-m antennas. Figure 3 shows a diagram of the experiment setup. Eight duplicated 512 MHz bands were processed through RDBE backends to produce four 10GigE data streams of 4 Gbps each, which were recorded at each station to 32 disks on a Mark 6 system. The data were processed with the DiFX correlator at Haystack Observatory. The cross-correlation of all eight bands showed nominal results, verifying the operation of the prototype Mark 6 system.

## Acknowledgements

We wish to thank Ahmed Akigray (Caltech), Sandy Weinreb (Caltech), and Bill Imbriale (JPL) for their contributions to the development of the GGAO and Westford receiver frontends.

## References

- [1] Akgiray, A., Weinreb, S., Imbriale, W., and Beaudoin, C. "Circular Quadruple-Ridged Flared Horn Achieving Near-Constant Beamwidth Over Multi-Octave Bandwidth; Design, Measurements and System Performance," Submitted for Publication to IEEE Transactions on Antennas and Propagation.
- [2] Beaudoin, C. and Cappallo, S., MOBLAS7 and NG SLR Radar Power Level Measurements Collected at GGAO, MIT Haystack Observatory VLBI Broad Band Memo Series, No. 37, 2011.
- [3] Beaudoin, C., Corey, B.E., Petrachenko, W.T., "Radio frequency compatibility of VLBI, SLR, and DORIS at GGOS stations," poster presented at AGU 2010 fall meeting in San Francisco, CA.



# IAA Technology Development Center Report 2011

*Dmitry Marshalov, Evgeny Nosov, Leonid Fedotov, Dmitry Ivanov, Andrey Karpichev*

## 1. R1002M Data Acquisition System (DAS)

The new DAS R1002M is developed by IAA RAS for replacement of existing analog DASs of the VLBI network “Quasar” [1]. The R1002M system was set in operation at the Svetloe, Zelenchukskaya, and Badary observatories.

R1002M uses digital signal processing on video frequencies and provides enhanced performance. It is compatible with existing analog DASs. The system consists of 16 Base Band Converters (BBC), IF-distributor, Clock Generator, Data Stream Combining Board (DSCB), and auxiliary units (Figure 1). It has four IF-inputs which can be electronically connected to the BBCs in the required way by IF-distributor unit. The BBCs’ output data streams are combined via DSCB and available in its output in VSI-H format with up to 2048 Mbps data rate (Table 1). The DAS is well suited to work with the Mark 5B+ recording system, but it can also work with Mark 5B in case of 1024 Mbps and lower data rates. For proper synchronization, the DAS is required for 1PPS and 5 or 10 MHz signals. The clock generator automatically determines which input reference frequency (5 or 10 MHz) is used.

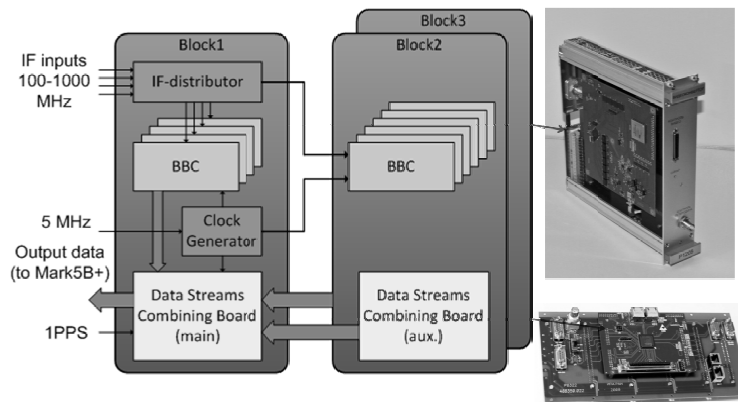

Figure 1. Simplified structure of R1002M DAS and pictures of the BBC and DSCB.

In R1002M the translation to baseband is performed by high quality analog mixer and local oscillator (LO). The output signals of the mixer are then digitized, and all subsequent processing is implemented by an FPGA. The digitizing is performed by 2-channels analog-to-digital converter (ADC) with a sample rate of 64 Msps (Figure 2). To separate the side bands a special multirate filter bank with complex-valued coefficients was developed and realized as FPGA. Use of this technique allows the achievement of a relatively high image rejection rate. The typical value for the digital BBC is  $-40$  to  $-45$  dB (at frequencies below 16 MHz) while in existing analog BBCs the typical value is about  $-20$  to  $-25$  dB.

A few additional switchable FIR-filters are used for forming six possible bandwidths: 0.5, 2, 4, 8, 16, and 32 MHz. The resulting amplitude-frequency characteristics of the digital BBCs are made similar to BBCs of existing analog DASs for improving compatibility between the systems.

Table 1. R1002M DAS specification

Input frequency range	100 to 1000 MHz
Number of IF-inputs	4
Number of channels (BBCs)	16
Selectable bandwidths	0.5, 2, 4, 8, 16, 32 MHz
Separated sidebands	Both lower and upper
Image rejection rate (typ.)	-40 to -45 dB
Commutation of input and output signals	Electronically
Local oscillators phase noise (rms)	$\leq 0.7^\circ$ (measured in 30 Hz÷30 MHz range)
Ripple of amplitude-frequency response of the BBCs	$\leq 0.3$ dB
Output data format	VSI-H
Output data rate	Up to 2 Gbps
Available control interfaces	RS-232, RS-485, 100/10 Ethernet
Total dimension (three 19" subracks)	445 × 950 × 315 mm

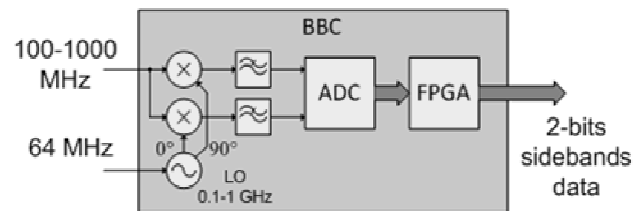

Figure 2. Simplified structure of the BBC.

From November 2011 all observations on the VLBI network “Quasar” have been performed by using R1002M DAS (Figure 3). It decreases the errors of EOP measurements (root-mean square deviation from the IERS 08 C04 series) on network “Quasar” to 0.38 mas for Celestial Pole position, 1 mas for Pole position, and 34 microseconds for Universal Time.

## 2. Broadband Phase Calibration System

The primary goal of the phase calibration system is to monitor the instrumental phase delay. For this purpose a spectrally pure reference signal is transmitted by cable to the mirror room of the radio telescope where it synchronizes generator of very short impulses of about 40 ps duration. In the current phase calibration system the impulses are injected through direction coupler into the input of receiver before the first LNA and passed with the received signal through receiver and data acquisition devices to digitization, after which the phases of the tones are extracted.

The broadband phase calibration system has been developed for the Russian VLBI new generation network. The goal of this phase calibration system is to radiate phase cal impulses from a special broadband feed (TEM horn, Figure 4) located ahead of the receiving feed. The main advantage of injecting phase cal ahead of the receiving feed is in putting most of the VLBI signal path into the phase calibration loop.

The broadband phase calibration system consists of TEM horn connected to the generator of picosecond-level impulses. The generator is placed into the thermo stating block, providing a time-



Figure 3. R1002M DAS and Mark 5B+ in Svetloe observatory.

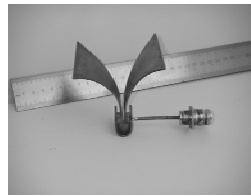

Figure 4. TEM horn.

constant temperature. All of the system together with power units is located in the all-weather plastic case, which easily mounts on a metal ware of a radio telescope.

The breadboard model of the broadband phase calibration system has been mounted on a radio telescope in the “Svetloe” observatory (Figure 5), and some testing on radiation of a phase calibration signal through a broadband horn has been carried out.

The impulses of two signals are registered upon exiting the receiver. The first impulse is from the regular generator of picosecond-level impulses, and the second is from the block of the broadband phase calibration system (Figure 6). These experiments showed the absence of multipath effects in the external radiation phase cal signal.

However, further research has revealed essential non-uniformity of phase calibration signal in different bands. Power of a cal signal upon exit of the S and X-band receivers differs by 10 dB. Analytical estimations (calculated by taking into account horn gain, losses in a radio line and gain of receivers) and experimental values of phase calibration power upon exit of the S and X-band receivers are represented in Table 2.

At the same time, in all channels of the receiver equipment the signal has sufficient (and at places even superfluous) power for the correct operation of the phase calibration system. It means that additional balance of power at various places along a frequency band is needed. Probably, the cascade of the adjustable filters located between the picosecond-level generator and the TEM horn is capable of solving this problem. But it demands additional research.

Table 2. Power of a cal signal upon exit of S and X-band receivers

Band	Power of a signal upon exit of receivers	
	Analytical estimations	Experimental
X	-80 dBm	-85 dBm
S	-70 dBm	-72 dBm



Figure 5. The breadboard model of the broadband phase calibration system mounted on a radio telescope (“Svetloe” observatory).

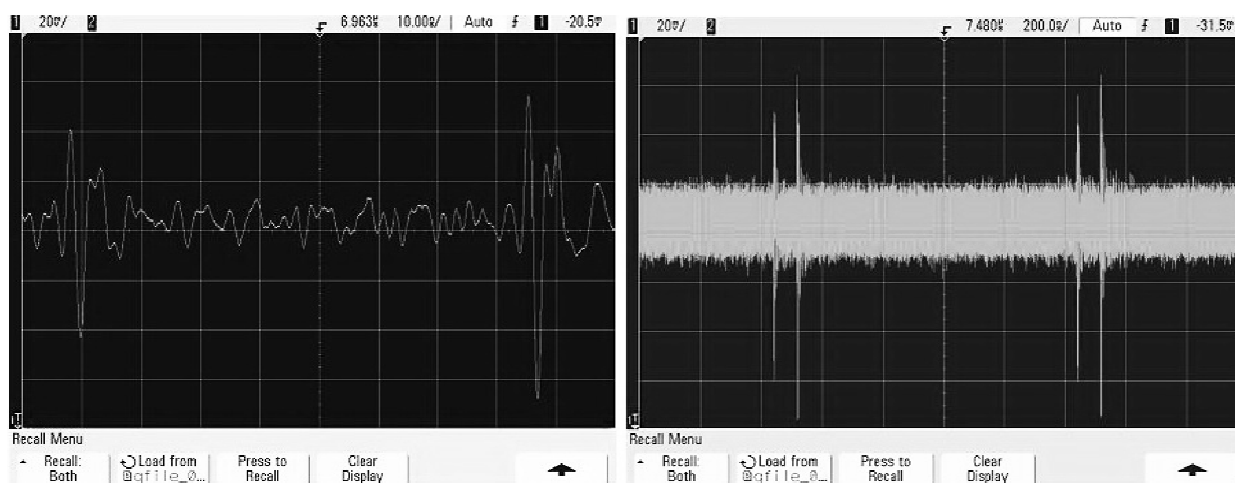

Figure 6. Oscillogram of output signal for S-band receiver.

## References

- [1] S. A. Grenkov, E. V. Nosov, L. V. Fedotov, N. E. Koltsov. A Digital Radio Interferometric Signal Conversion System. Instruments and Experimental Techniques, 2010, Vol. 53, No. 5. P. 675–681.

# Technology Development Center at NICT

*Kazuhiro Takefuji, Hideki Ujihara*

## Abstract

The National Institute of Information and Communications Technology (NICT) has led a development of the VLBI technique and has been keeping high activities in both observations and technical developments. This report gives a review of the Technology Development Center (TDC) at NICT and summarizes recent activities.

## 1. NICT as an IVS-TDC and Staff Members

The National Institute of Information and Communications Technology (NICT) has published a newsletter, “IVS NICT-TDC News (former IVS CRL-TDC News)”, at least once a year in order to inform readers about NICT’s development of VLBI-related technology as an IVS Technology Development Center. The newsletter is available at the following URL: <http://www2.nict.go.jp/w/w114/stmg/ivstdc/news-index.html>. Table 1 lists the staff members at NICT who are involved in the VLBI Technology Development Center at NICT.

Table 1. Staff Members of NICT TDC as of January 2012 (alphabetical).

AMAGAI, Jun	HASEGAWA, Shingo	HOBIGER, Thomas	ICHIKAWA, Ryuichi
KAWAI, Eiji	KONDO, Tetsuro	KOYAMA, Yasuhiro	MIYAUCHI, Yuka
SEKIDO, Mamoru	TAKEFUJI, Kazuhiro	TSUTSUMI, Masanori	UJIHARA, Hideki

## 2. Current Status and Activities

### 2.1. RF Direct Sampling System for Geodetic VLBI

We have carried out a test VLBI experiment by using a so-called “RF direct sampling” technique. In a conventional VLBI system, RF signals are converted to IF band signals, then converted to baseband signals using an analog baseband converter, then sampled and converted to digital signals. IF signals travel a few hundred meters down a coaxial cable or an optical cable; so temperature variations will affect the cable and change the internal group delay. Phase calibration, which inserts 1 or 5 MHz step comb signals in frequency before a low noise amplifier, will compensate for this group delay. However, if RF signals are sampled just after the low noise amplifier, a phase calibration system is not necessary. Recently it became possible to sample IF signals directly due to progress of the sampling device, and then a digital baseband converter, like ADS3000+ [1], was developed. Now some sampling devices have a wider input frequency bandwidth – more than 10 GHz. If RF signals such as 8 GHz band signals can be sampled directly, an IF converter is omissible from the receiving system. This will reduce the cost of the system associated with the converter and will increase the reliability of the system. ADX-831, developed by the ELECS INDUSTRY CO. LTD., is a sampler that has an input band width of 10 GHz.

We have carried out a test VLBI observation with ADX-831 to evaluate the feasibility of the RF direct sampling VLBI. The RF direct sampling system was installed at the Tsukuba 32-m and Kashima 11-m antennas. Figure 1 shows a system block diagram. The RF direct sampling has sampling modes of 2bit-1024Msps. According to the Nyquist theorem, it needs 18 GHz speed to record X-band (9 GHz) signal. However since the X-band bandwidth is around 1 GHz, a 1024 MHz sampling speed (under sampling of digital technique) was almost enough. The signal after 1024 MHz sampling (0 to 512 MHz) is exactly the same as the band-filtered signal (8192 to 8704 MHz). It acts like a “digital” base band converter. High order sampling is mainly used for filtered band; then the sampled band can be reconstructed to the original. But an anti-alias filter was not inserted before the sampler in this case, so other folded signals from out of band ( $\leq 8192$  MHz and  $\geq 8704$  MHz) will overlap. The overlapped signal will make noise (system temperature) increase, reducing the fringe amplitude. But we could detect fringes of overlapped signals with difference of fringe rotation (Figure 2). So we think that the reduced fringe amplitude will be canceled after bandwidth synthesis. This technique is named “DSAMS” (Direct Sampling Applied for Mixed Signals). DSAMS was also adopted to S/X band which were connected after LNA in RF frequency. Figure 3 shows synthesized S and X-band and their fringes [2].

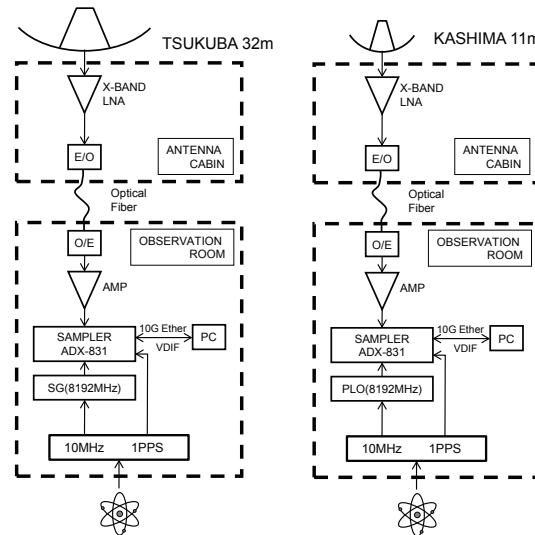

Figure 1. A system block diagram. RF direct sampling was operated at Kashima 11-m and Tsukuba 32-m.

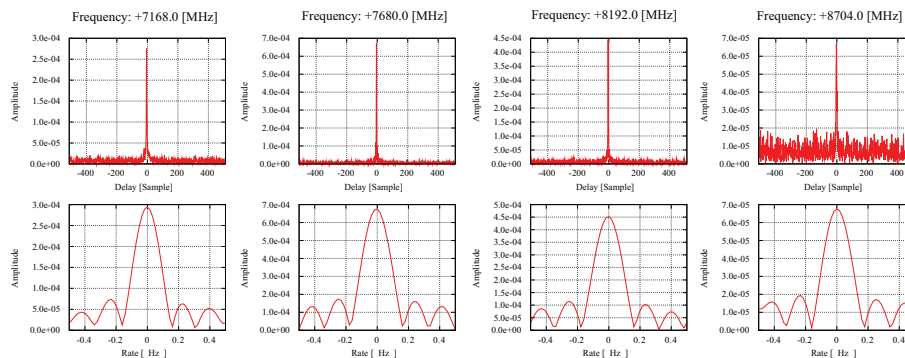

Figure 2. First fringes for DSAMS (Direct Sampling Applied for Mixed Signals) applied for X-band VLBI. The sampling mode of ADX-831 is 2bit-1024Msps. All four X-band fringes were simultaneously obtained with just one sampler.

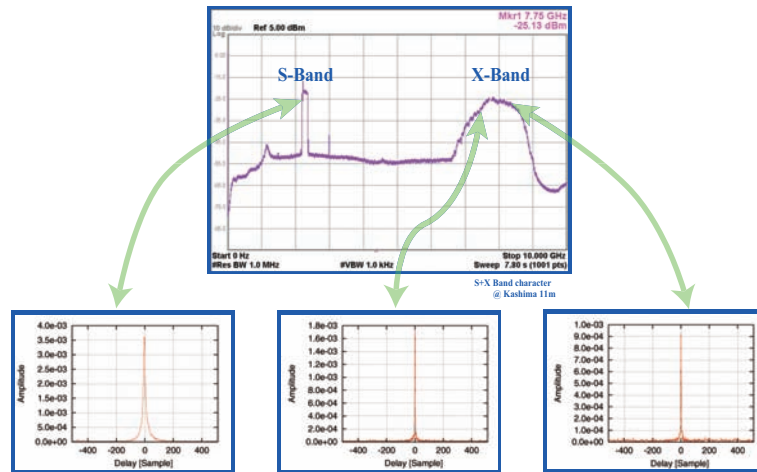

Figure 3. First fringe of DSAMS (Direct sampling applied for mixed signals) applied for geodetic VLBI. The sampling mode of ADX-831 is 2bit-1024Mps. Fringes of S-band and X-band were simultaneously obtained with only one sampler.

### 3. Development of Wide Band Feeds

Wideband feeds are being developed at NICT, NAOJ, and other Japanese universities for VLBI2010, SKA, and MARBLE. SKA is an international radio astronomy project for constructing the Square Kilometer Array. MARBLE is a small portable VLBI station developed by NICT and GSI in Japan. They all need wideband feed with a 1:10 or more frequency ratio.

We are now studying Arrayed Travel Wave Antennas (Arrayed TWA) with dual linear polarization for them, which is shown in Figure 4. Several elemental feeds were tested, and their beam patterns were measured at MET-LAB at Kyoto University in 2011. Grating robes are clearly seen [Figure 5], because of the lack of a central feed element, which was not yet placed properly. Also, numerical simulations were carried out with COMSOL for the feed elements [Figure 6]. The element size is ( $L = 280\text{mm}$ )  $\times$  ( $W = 120\text{mm}$ )  $\times$  ( $t = 1\text{mm}$ ), and the relative permittivity of the dielectric substrate is tested on  $\epsilon_r = 1, 2.2, 4, 10$ . We are now planning to assemble the elements into an Arrayed TWA for evaluation of beam shaping before installing it on the MARBLE.

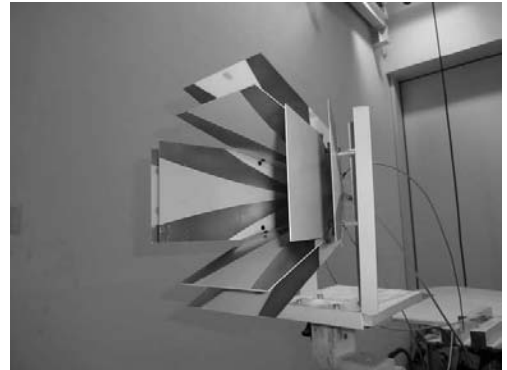
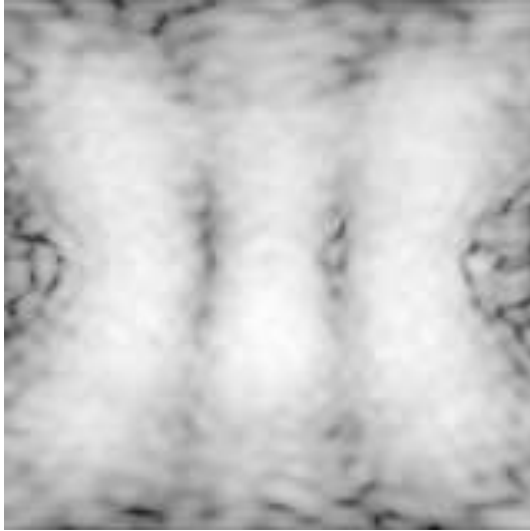
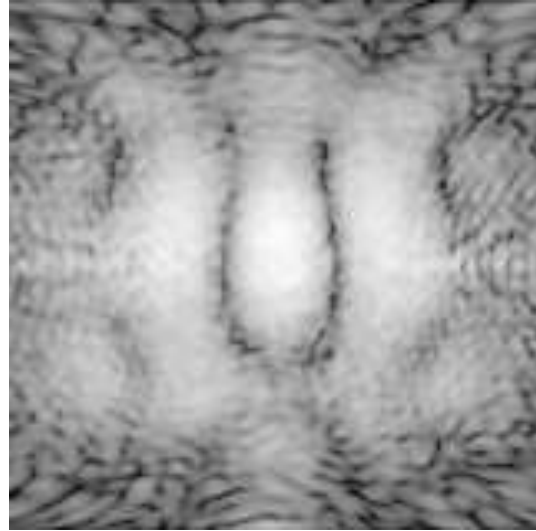

Figure 4. Experimental elements for wideband feeds.



Farfield pattern of the feed elements at 3 GHz



Farfield pattern of the feed elements at 4 GHz

Figure 5. Farfield patterns of experimental elements for the wideband feed [Figure 4].

Ey field on the element at 6 GHz  $\epsilon_r = 2.2$ Ey field on the element at 6 GHz  $\epsilon_r = 10$ 

Figure 6. Simulated E field component parallel to the substrate of feed element [Figure 4].

## References

- [1] Takefuji K., Koyama Y., Takeuchi H., First Fringe Detection with Next-Generation A/D Sampler ADS3000+, IVS TDC News, No. 30, pp.17-21, 2009.
- [2] Takefuji K., Kondo T., Sekido M., RF direct sampling applied for geodetic VLBI, 2012, in preparation.

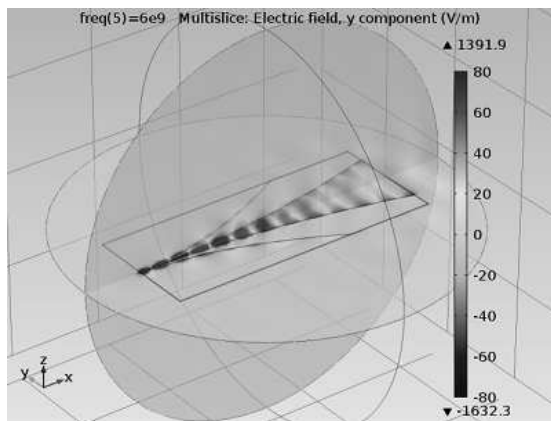
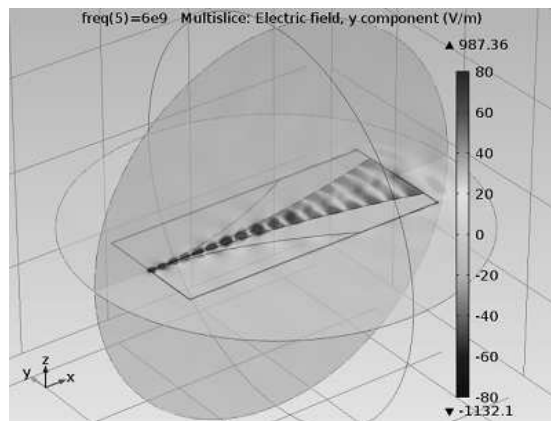

# Onsala Space Observatory – IVS Technology Development Center

*Miroslav Pantaleev, Ulf Klyenfall, Leif Helldner, Karl-Åke Johansson, Rüdiger Haas*

## Abstract

The present report describes in brief the technical development done during 2011 at the Onsala Space Observatory in relation to geodetic/astrometric VLBI. The activities focussed on the development of a front-end for VLBI2010 and the integration of a digital back end in the VLBI system.

## 1. A Front-end for VLBI2010

During 2011 the activities related to the improvement of the performance of an Eleven feed for VLBI2010 can be summarized as follows:

- design of passive balun
- design of new feed petals
- cryogenic tests and noise model

This work was done as a collaboration with the Antenna Group at the Department of Signals and Systems at Chalmers University of Technology. The integration of the Eleven feed into a cryogenic front-end suitable for VLBI2010 was done in collaboration with Omnisys AB.

### 1.1. Design of a Passive Balun

Two designs for passive feeding networks were developed at the Antenna Group during 2011. At the Onsala Space Observatory (OSO) we made the mechanical design suitable for cryogenic operation and produced two prototypes, see Figure 1.

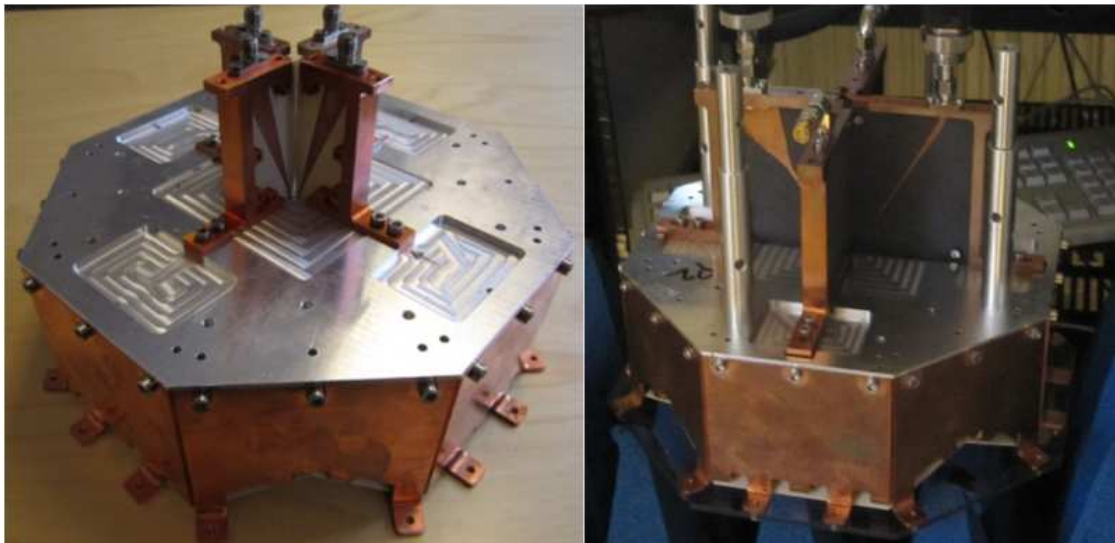

Figure 1. Balun-fed Eleven feeds with linear taper (left) and with Klopfenstein taper (right).

The design of the passive feeding solution to the Eleven feed consists of two passive ultra wideband (UWB) baluns and two UWB power dividers [1]. This feeding solution transforms the four differential ports of the feed to two single ended ports, one for each polarization. Therefore, four differential low noise amplifiers (LNAs) can be replaced by two single ended LNAs, which leads to a much simpler and lower cost system. Two versions of UWB baluns have been developed: a linear taper and a Klopfenstein taper one. Figure 2 shows the measured performance. The prototype with the Klopfenstein taper balun has an improved performance compared to the one with the linear taper balun.

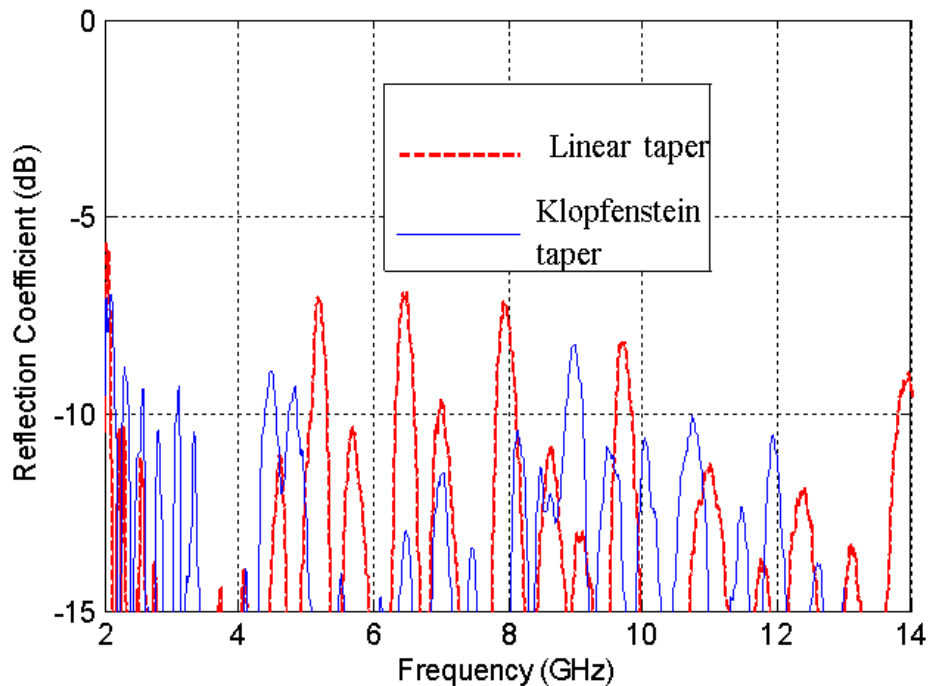

Figure 2. Measured reflection coefficient for the two balun-fed Eleven feed prototypes: linear taper (dashed line, red) and Klopfenstein taper (solid line, blue).

## 1.2. Design of New Feed Petals

During the last months of 2011 we were working with the mechanical implementation and prototype fabrication of a new circular Eleven feed that was designed by the Antenna Group at Chalmers. Figure 3 shows the CAD model of the production prototype. The circular Eleven feed is constructed of “circularly” curved folded dipoles on a flat printed circuit board (PCB), with the aim of making this antenna structure more rotationally symmetric at a very low manufacturing cost. According to the simulations, it is expected that the circular Eleven feed achieves a BOR1 (body of revolution type 1) efficiency of better than  $-1$  dB over a decade bandwidth of 1.3–14.0 GHz. This is a significant progress for decade-bandwidth feed technology.

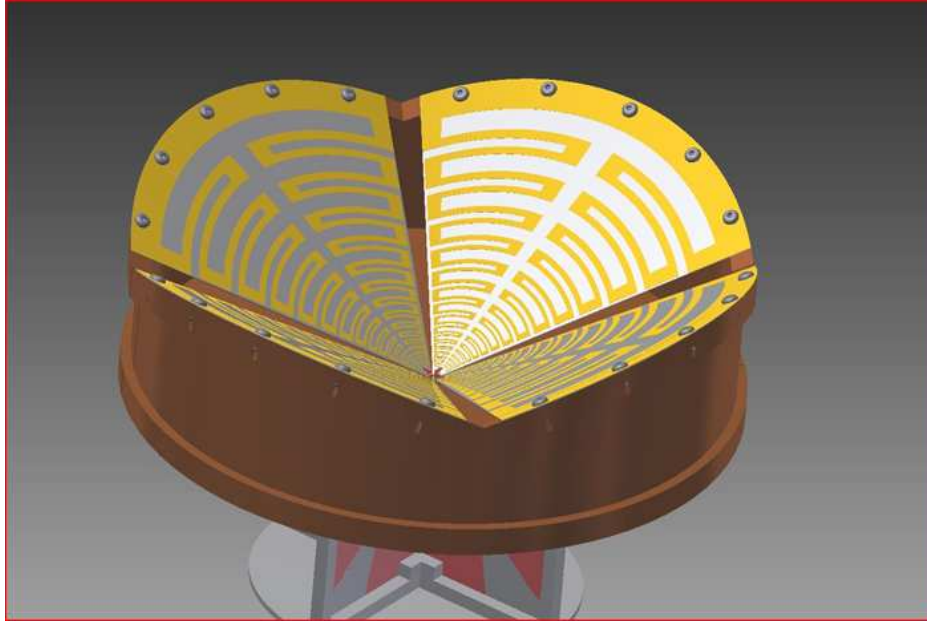

Figure 3. Drawing of the new circular Eleven feed.

### 1.3. Cryogenic Tests and Noise Model

To characterize the system noise, the 2–13 GHz Eleven feed prototype was integrated with a 20 K cryostat. The feed prototype has eight  $50\ \Omega$  ports, four for each polarization. Since only four LNAs were available for the tests, the ports for one polarization were terminated with  $50\ \Omega$  loads. The LNAs are CITCRY01-12 wideband cryogenic  $50\ \Omega$  amplifiers, purchased from Caltech. The feed system including the cryostat was placed outdoors, with the feed window pointing upwards. The receiver noise was measured by the Y-factor method using hot and cold loads. An absorber at ambient temperature is used as the hot load and the sky as the cold load. A metal pyramid is used as a shielding for the cryostat, in order to reduce the noise pick-up from the ground and the surroundings.

Although the tests were done at the observatory, which is a radio-quiet zone, a strong RFI was observed in the cold spectra from 2 to 3 GHz. Since the system was shielded with the absorber for the hot load measurement when measuring the hot load, the RFI cannot be calibrated out, and the measured Y-factor is not representative for the frequency range 2–3 GHz. A new algorithm for improving the data analysis in the 2–3 GHz band is under development.

The measured system noise temperature was compared with the one predicted by our noise model, shown in Figure 4. The model predictions agree well with the measurements.

## 2. Integration of a Digital Backend

In 2011 the observatory purchased a digital backend of type DBBC (Digital Base Band Converter) [2], and the work to adapt it to the observatory's instruments was initiated. For geodetic S/X-observations we use coaxial cables to carry the IF-signals from the 20-m telescope down to

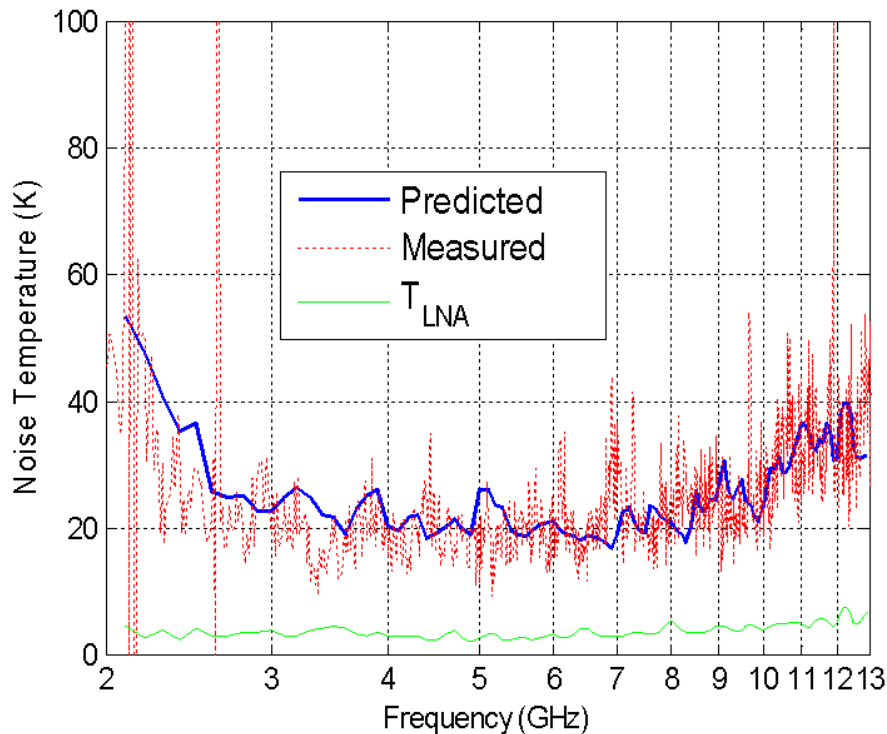

Figure 4. Measured (dashed line, red) and predicted system noise temperature (solid line, blue). The noise temperature of the LNAs is shown as thin solid line in green.

the VLBI backends (Mark IV and DBBC). This implies that the band pass has a slope, with attenuation increasing with increasing frequency. Since the dynamic range of the DBBC is limited, such a band pass slope will degrade the usable signal range of the digital system. We thus decided to introduce equalizers for the IF-signals, and the work to implement these is ongoing.

### 3. Outlook and Future Plans

We will continue to work on the development of an Eleven feed for VLBI2010. We also aim at preparing the 20-m telescope to become fully compatible with VLBI2010 within the next few years.

### References

- [1] Raza H, Yang J, Pantaleev M (2011) A compact UWB passive balun solution for cryogenic 2–13 GHz Eleven feed for future wideband radio telescopes. *5th Eur. Conf. on Antennas Propagat. (EuCAP2011)*, Rome, Italy, 11-15 April 2011.
- [2] Tuccari G (2004) DBBC - a wide band digital base band convertor, In: *International VLBI Service for Geodesy and Astrometry 2004 General Meeting Proceedings*, edited by Nancy R. Vandenberg and Karen D. Baver, NASA/CP-2004-212255, 234–237.

# Bibliography

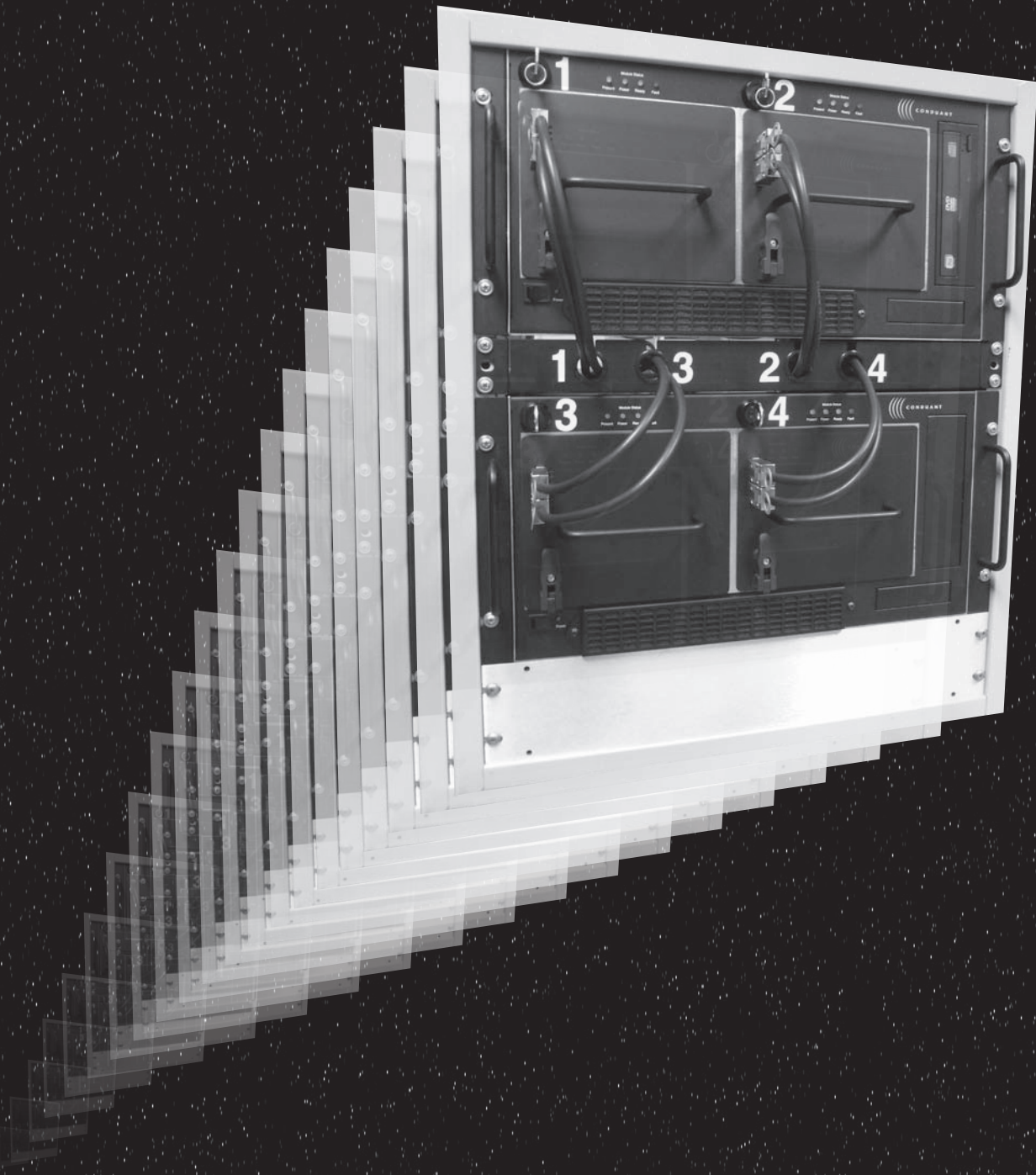

# Bibliography



---

## Bibliography

### 1. Introduction

The following bibliography compiles papers that were published in the field of geodetic and astrometric VLBI during the year 2011. There is no distinction between peer-reviewed, reviewed, or proceedings publications. This list is by no means exhaustive.

### 2. Geodetic and Astrometric VLBI Publications of 2011

- W. ALEF, H. ROTTMANN, A. BERTARINI, A. MÜSKENS: “Bonn Correlator Status Report”. In: Proceedings of the 20th Meeting of the European VLBI Group for Geodesy and Astrometry, edited by W. Alef, S. Bernhart, A. Nothnagel, Schriftenreihe des Instituts für Geodäsie und Geoinformation der Universität Bonn, Nr. 22, ISSN 1864-1113, 57–59, 2011.
- P. ANDERSEN: “FFI Analysis Center”. In: International VLBI Service for Geodesy and Astrometry 2010 Annual Report, edited by D. Behrend and K. Baver, NASA/TP-2011-215880, 192–193, 2011.
- P. ANDERSEN: “FFI Technology Development Center – Software Development”. In: International VLBI Service for Geodesy and Astrometry 2010 Annual Report, edited by D. Behrend and K. Baver, NASA/TP-2011-215880, 268, 2011.
- T. ARTZ, A. NOTHNAGEL, P. STEIGENBERGER, S. TESMER: “Evaluation of Combined Sub-daily UT1 Estimates from GPS and VLBI Observations”. In: Proceedings of the 20th Meeting of the European VLBI Group for Geodesy and Astrometry, edited by W. Alef, S. Bernhart, A. Nothnagel, Schriftenreihe des Instituts für Geodäsie und Geoinformation der Universität Bonn, Nr. 22, ISSN 1864-1113, 97–101, 2011.
- T. ARTZ, S. TESMER NÉE BÖCKMANN, A. NOTHNAGEL: “Assessment of periodic sub-diurnal Earth rotation variations at tidal frequencies through transformation of VLBI normal equation systems”. *Journal of Geodesy*, 85(9), doi:10.1007/s00190-011-0457-z, 565–584, 2011.
- S. BACHMANN, R. HEINKELMANN, M. GERSTL: “BKG/DGFI Combination Center Annual Report 2010”. In: International VLBI Service for Geodesy and Astrometry 2010 Annual Report, edited by D. Behrend and K. Baver, NASA/TP-2011-215880, 183–186, 2011.
- C. BARACHE, S. LAMBERT: “Paris Observatory (OPAR) Data Center”. In: International VLBI Service for Geodesy and Astrometry 2010 Annual Report, edited by D. Behrend and K. Baver, NASA/TP-2011-215880, 167–170, 2011.
- C. BEAUDOIN, B. COREY, A. NIELL, A. WHITNEY: “Haystack Observatory Technology Development Center”. In: International VLBI Service for Geodesy and Astrometry 2010 Annual Report, edited by D. Behrend and K. Baver, NASA/TP-2011-215880, 272–275, 2011.
- C. BEAUDOIN, B. WHITTIER: “Sensitivity evaluation of two VLBI2010 candidate feeds”. In: Proceedings of the 20th Meeting of the European VLBI Group for Geodesy and Astrometry, edited by W. Alef, S. Bernhart, A. Nothnagel, Schriftenreihe des Instituts für Geodäsie und Geoinformation der Universität Bonn, Nr. 22, ISSN 1864-1113, 71–73, 2011.
- D. BEHREND: “Coordinating Center Report”. In: International VLBI Service for Geodesy and

- Astrometry 2010 Annual Report, edited by D. Behrend and K. Baver, NASA/TP-2011-215880, 13–15, 2011.
- S. BERNHART, A. BERTARINI, A. MÜSKENS, W. ALEF: “The Bonn Astro/Geo Correlator”. In: International VLBI Service for Geodesy and Astrometry 2010 Annual Report, edited by D. Behrend and K. Baver, NASA/TP-2011-215880, 133–136, 2011.
- A. BERTARINI, A. ROY, B. COREY, C. WALKER, W. ALEF, A. NOTHNAGEL: “Effects on geodetic VLBI measurements due to polarization leakage in S/X receivers”. *Journal of Geodesy*, 85(10), doi:10.1007/s00190-011-0478-7, 715–721, 2011.
- I. BEZRUKOV, A. FINKELSTEIN, A. IPATOV, M. KAIDANOVSKY, A. MIKHAILOV, A. SALNIKOV, V. YAKOVLEV: “The Quasar Network Observations in e-VLBI Mode”. In: Proceedings of the 20th Meeting of the European VLBI Group for Geodesy and Astrometry, edited by W. Alef, S. Bernhart, A. Nothnagel, Schriftenreihe des Instituts für Geodäsie und Geoinformation der Universität Bonn, Nr. 22, ISSN 1864-1113, 49–51, 2011.
- G. BIANCO, G. COLUCCI, F. SCHIAVONE: “Matera CGS VLBI Station”. In: International VLBI Service for Geodesy and Astrometry 2010 Annual Report, edited by D. Behrend and K. Baver, NASA/TP-2011-215880, 54–57, 2011.
- D. BOBOLTZ, A. FEY, N. GEIGER, K. KINGHAM, D. HALL: “U.S. Naval Observatory VLBI Analysis Center”. In: International VLBI Service for Geodesy and Astrometry 2010 Annual Report, edited by D. Behrend and K. Baver, NASA/TP-2011-215880, 257–260, 2011.
- J. BÖHM, H. SPICAKOVA, L. URQUHART, P. STEIGENBERGER, H. SCHUH: “Impact of A Priori Gradients on VLBI-Derived Terrestrial Reference Frames”. In: Proceedings of the 20th Meeting of the European VLBI Group for Geodesy and Astrometry, edited by W. Alef, S. Bernhart, A. Nothnagel, Schriftenreihe des Instituts für Geodäsie und Geoinformation der Universität Bonn, Nr. 22, ISSN 1864-1113, 128–132, 2011.
- S. BÖHM, H. SCHUH: “Response of the Earth system to zonal tidal forcing examined by VLBI based dUT1 variations”. In: Proceedings of the ‘Journées 2010 Systèmes de Référence Spatio-temporels’, edited by N. Capitaine, Observatoire de Paris, 145–148, 2011.
- S. BOLOTIN, J. GIPSON, D. GORDON, D. MACMILLAN: “Current Status of Development of New VLBI Data Analysis Software”. In: Proceedings of the 20th Meeting of the European VLBI Group for Geodesy and Astrometry, edited by W. Alef, S. Bernhart, A. Nothnagel, Schriftenreihe des Instituts für Geodäsie und Geoinformation der Universität Bonn, Nr. 22, ISSN 1864-1113, 86–88, 2011.
- G. BOURDA, A. COLLIOUD, P. CHARLOT, R. PORCAS, S. GARRINGTON: “Towards an accurate alignment of the VLBI frame and the future Gaia frame – VLBI observations of optically-bright weak extragalactic radio sources: Status and future prospects”. In: Proceedings of the 20th Meeting of the European VLBI Group for Geodesy and Astrometry, edited by W. Alef, S. Bernhart, A. Nothnagel, Schriftenreihe des Instituts für Geodäsie und Geoinformation der Universität Bonn, Nr. 22, ISSN 1864-1113, 158–161, 2011.
- J. CAMPBELL: “EVGA – Looking back at the early beginnings”. In: Proceedings of the 20th Meeting of the European VLBI Group for Geodesy and Astrometry, edited by W. Alef, S. Bernhart, A. Nothnagel, Schriftenreihe des Instituts für Geodäsie und Geoinformation der Universität Bonn, Nr. 22, ISSN 1864-1113, 1–8, 2011.
- P. CHARLOT, A. BELLANGER, G. BOURDA, A. COLLIOUD, M. ZHANG, A. BAUDRY: “Report for



- 2010 from the Bordeaux IVS Analysis Center”. In: International VLBI Service for Geodesy and Astrometry 2010 Annual Report, edited by D. Behrend and K. Baver, NASA/TP-2011-215880, 179–182, 2011.
- A. COLLIOD: “IVS Live: All IVS on your desktop”. In: Proceedings of the 20th Meeting of the European VLBI Group for Geodesy and Astrometry, edited by W. Alef, S. Bernhart, A. Nothnagel, Schriftenreihe des Instituts für Geodäsie und Geoinformation der Universität Bonn, Nr. 22, ISSN 1864-1113, 14–18, 2011.
- F. COLOMER, J. GÓMEZ-GONZÁLEZ, J. LÓPEZ-FERNÁNDEZ, S. GARCÍA-ESPADA, P. DE VICENTE: “Instituto Geográfico Nacional of Spain”. In: International VLBI Service for Geodesy and Astrometry 2010 Annual Report, edited by D. Behrend and K. Baver, NASA/TP-2011-215880, 117–120, 2011.
- L. COMBRINCK, M. GAYLARD, J. QUICK, M. NICKOLA: “Hartebeesthoek Radio Astronomy Observatory (HartRAO)”. In: International VLBI Service for Geodesy and Astrometry 2010 Annual Report, edited by D. Behrend and K. Baver, NASA/TP-2011-215880, 35–38, 2011.
- R. CURTIS: “Kokee Park Geophysical Observatory”. In: International VLBI Service for Geodesy and Astrometry 2010 Annual Report, edited by D. Behrend and K. Baver, NASA/TP-2011-215880, 50–53, 2011.
- A. DELLER: “PSR $\pi$ : A large VLBA pulsar astrometry program”. In: Proceedings of the 20th Meeting of the European VLBI Group for Geodesy and Astrometry, edited by W. Alef, S. Bernhart, A. Nothnagel, Schriftenreihe des Instituts für Geodäsie und Geoinformation der Universität Bonn, Nr. 22, ISSN 1864-1113, 178–182, 2011.
- D. DETTMERING, R. HEINKELMANN, M. SCHMIDT: “Systematic differences between VTEC obtained by different space-geodetic techniques during CONT08”. *Journal of Geodesy*, 85(7), doi:10.1007/s00190-011-0473-z, 443–451, 2011.
- P. DE VICENTE, R. BOLAÑO, C. ALMENDROS: “DBBC installation and tests at the 40-m radiotelescope”. Informe Técnico OAN 2011-8, 24 pp., 2011.  
<http://www1.oan.es/informes/archivos/IT-OAN-2011-8.pdf>
- P. DE VICENTE, R. BOLAÑO, L. BARBAS: “Monitor setup and software for the T4 Science hydrogen maser 66”. Informe Técnico OAN 2011-5, 15 pp., 2011.  
<http://www1.oan.es/informes/archivos/IT-OAN-2011-5.pdf>
- P. DE VICENTE, S. GARCÍA-ESPADA: “Testing the VLBI system prior to the CONT11 campaign”. Informe Técnico OAN 2011-6, 31 pp., 2011.  
<http://www1.oan.es/informes/archivos/IT-OAN-2011-6.pdf>
- P. DE VICENTE, F. TERCERO, T. FINN, J. ABAD, J. FERNÁNDEZ, J. YAGÜE: “Installation and measurements of efficiency for the new membrane at the vertex of the 40-m radiotelescope”. Informe Técnico OAN 2011-4, 25 pp., 2011.  
<http://www1.oan.es/informes/archivos/IT-OAN-2011-4.pdf>
- K. DOI, K. SHIBUYA, Y. AOYAMA: “JARE Syowa Station 11-m Antenna, Antarctica”. In: International VLBI Service for Geodesy and Astrometry 2010 Annual Report, edited by D. Behrend and K. Baver, NASA/TP-2011-215880, 89–92, 2011.
- G. ENGELHARDT, V. THORANDT, D. ULLRICH: “VLBI Analysis at BKG”. In: Proceedings of the 20th Meeting of the European VLBI Group for Geodesy and Astrometry, edited by W. Alef, S. Bernhart, A. Nothnagel, Schriftenreihe des Instituts für Geodäsie und Geoinformation der

- Universität Bonn, Nr. 22, ISSN 1864-1113, 102–104, 2011.
- M. ETTL, A. NEIDHARDT, M. MÜHLBAUER, C. PLÖTZ, H. HASE, S. SOBARZO, C. HERRERA, E. OÑATE, P. ZAROR, F. PEDREROS, O. ZAPATO: “Experiences with regular remote attendance towards new observation strategies”. In: Proceedings of the 20th Meeting of the European VLBI Group for Geodesy and Astrometry, edited by W. Alef, S. Bernhart, A. Nothnagel, Schriftenreihe des Instituts für Geodäsie und Geoinformation der Universität Bonn, Nr. 22, ISSN 1864-1113, 35–37, 2011.
- M. ETTL, A. NEIDHARDT, H. ROTTMANN, M. MÜHLBAUER, C. PLÖTZ, E. HIMWICH, C. BEAUDOIN, A. SZOMORU: “Concepts for continuous quality monitoring and station remote control”. In: Proceedings of the 20th Meeting of the European VLBI Group for Geodesy and Astrometry, edited by W. Alef, S. Bernhart, A. Nothnagel, Schriftenreihe des Instituts für Geodäsie und Geoinformation der Universität Bonn, Nr. 22, ISSN 1864-1113, 22–25, 2011.
- A. FEY, D. BOBOLTZ, R. OJHA, R. GAUME, K. KINGHAM: “USNO Analysis Center for Source Structure Report”. In: International VLBI Service for Geodesy and Astrometry 2010 Annual Report, edited by D. Behrend and K. Baver, NASA/TP-2011-215880, 261–263, 2011.
- A. FINKELSTEIN, A. SALNIKOV, A. IPATOV, S. SMOLENTSEV, I. SURKIS, I. GAYAZOV, I. RAHIMOV, A. DYAKOV, R. SERGEEV, E. SKURIKHINA, S. KURDUBOV: “EOP determination from observations of Russian VLBI-network ‘Quasar’”. In: Proceedings of the 20th Meeting of the European VLBI Group for Geodesy and Astrometry, edited by W. Alef, S. Bernhart, A. Nothnagel, Schriftenreihe des Instituts für Geodäsie und Geoinformation der Universität Bonn, Nr. 22, ISSN 1864-1113, 82–85, 2011.
- D. GAMBIS, D. SALSTEIN, S. LAMBERT: “Use of atmospheric angular momentum forecasts for UT1 predictions: analyses over CONT08”. *Journal of Geodesy*, 85(7), doi:10.1007/s00190-011-0479-6, 435–441, 2011.
- S. GARCÍA-ESPADA, R. HAAS, F. COLOMER: “Application of ray-tracing through the high resolution numerical weather model HIRLAM applying the Conformal Theory of Refraction”. In: Proceedings of the 20th Meeting of the European VLBI Group for Geodesy and Astrometry, edited by W. Alef, S. Bernhart, A. Nothnagel, Schriftenreihe des Instituts für Geodäsie und Geoinformation der Universität Bonn, Nr. 22, ISSN 1864-1113, 133–137, 2011.
- I. GAYAZOV, E. SKURIKHINA: “Improved velocities of the ‘Quasar’ network stations”. In: Proceedings of the 20th Meeting of the European VLBI Group for Geodesy and Astrometry, edited by W. Alef, S. Bernhart, A. Nothnagel, Schriftenreihe des Instituts für Geodäsie und Geoinformation der Universität Bonn, Nr. 22, ISSN 1864-1113, 147–149, 2011.
- J. GIPSON: “Report on IVS-WG4”. In: Proceedings of the 20th Meeting of the European VLBI Group for Geodesy and Astrometry, edited by W. Alef, S. Bernhart, A. Nothnagel, Schriftenreihe des Instituts für Geodäsie und Geoinformation der Universität Bonn, Nr. 22, ISSN 1864-1113, 142–146, 2011.
- D. GORDON, C. MA, D. MACMILLAN, J. GIPSON, K. BAVER, S. BOLOTIN, K. LE BAIL: “GSFC VLBI Analysis Center”. In: International VLBI Service for Geodesy and Astrometry 2010 Annual Report, edited by D. Behrend and K. Baver, NASA/TP-2011-215880, 198–201, 2011.
- S. GULYAEV, T. NATUSCH, S. WESTON, N. PALMER, D. COLLETT: “Warkworth 12-m VLBI Station: WARK12M”. In: International VLBI Service for Geodesy and Astrometry 2010 Annual

- Report, edited by D. Behrend and K. Baver, NASA/TP-2011-215880, 105–108, 2011.
- R. HAAS, G. ELGERED, J. LÖFGREN, T. NING, H.-G. SCHERNECK: “Onsala Space Observatory - IVS Network Station”. In: International VLBI Service for Geodesy and Astrometry 2010 Annual Report, edited by D. Behrend and K. Baver, NASA/TP-2011-215880, 75–78, 2011.
- R. HAAS, T. HOBIGER, M. SEKIDO, Y. KOYAMA, T. KONDO, H. TAKIGUCHI, S. KURIHARA, K. KOKADO, D. TANIMOTO, K. NOZAWA, J. WAGNER, J. RITAKARI, A. MUJUNEN, M. UUNILA: “Near real-time monitoring of UT1 with geodetic VLBI”. In: Proceedings of the 20th Meeting of the European VLBI Group for Geodesy and Astrometry, edited by W. Alef, S. Bernhart, A. Nothnagel, Schriftenreihe des Instituts für Geodäsie und Geoinformation der Universität Bonn, Nr. 22, ISSN 1864-1113, 64–66, 2011.
- R. HAAS, H. SCHERNECK: “Onsala Space Observatory – IVS Analysis Center”. In: International VLBI Service for Geodesy and Astrometry 2010 Annual Report, edited by D. Behrend and K. Baver, NASA/TP-2011-215880, 240–243, 2011.
- K. HARADA, T. NAKAYAMA, T. KAMAJI, K. OZEKI: “8 Gbps High-Speed Sampling RF Direct A-D Converter ADX-831”. IVS NICT Technology Development Center News, No. 32, ISSN 1882-3432, 20–21, November 2011.
- H. HASE, D. BEHREND, C. MA, W. PETRACHENKO, H. SCHUH, A. WHITNEY: “The Future Global VLBI2010 Network of the IVS”. In: Proceedings of the 20th Meeting of the European VLBI Group for Geodesy and Astrometry, edited by W. Alef, S. Bernhart, A. Nothnagel, Schriftenreihe des Instituts für Geodäsie und Geoinformation der Universität Bonn, Nr. 22, ISSN 1864-1113, 78–81, 2011.
- R. HEINKELMANN, J. BÖHM, S. BOLOTIN, G. ENGELHARDT, R. HAAS, R. LANOTTE, D. MACMILLAN, M. NEGUSINI, E. SKURIKHINA, O. TITOV, H. SCHUH: “VLBI-derived troposphere parameters during CONT08”. *Journal of Geodesy*, 85(7), doi:10.1007/S00190-011-0459-x, 377–393, 2011.
- R. HEINKELMANN, M. SEITZ, M. GERSTL, H. DREWES: “DGFI Analysis Center Annual Report 2010”. In: International VLBI Service for Geodesy and Astrometry 2010 Annual Report, edited by D. Behrend and K. Baver, NASA/TP-2011-215880, 189–191, 2011.
- E. HIMWICH: “Network Coordinator Report”. In: International VLBI Service for Geodesy and Astrometry 2010 Annual Report, edited by D. Behrend and K. Baver, NASA/TP-2011-215880, 18–20, 2011.
- E. HIMWICH, J. GIPSON: “GSFC Technology Development Center Report”. In: International VLBI Service for Geodesy and Astrometry 2010 Annual Report, edited by D. Behrend and K. Baver, NASA/TP-2011-215880, 269–271, 2011.
- T. HOBIGER, J. AMAGAI, M. AIDA, T. GOTOH: “A GNSS-R system based on software-defined-radio”. IVS NICT Technology Development Center News, No. 32, ISSN 1882-3432, 7–10, November 2011.
- T. HOBIGER, M. SEKIDO, T. OTSUBO, T. GOTOH, T. KUBOOKA, H. TAKIGUCHI, H. TAKEUCHI: “VLBI analysis with c5++ – status quo and outlook”. In: Proceedings of the 20th Meeting of the European VLBI Group for Geodesy and Astrometry, edited by W. Alef, S. Bernhart, A. Nothnagel, Schriftenreihe des Instituts für Geodäsie und Geoinformation der Universität Bonn, Nr. 22, ISSN 1864-1113, 89–92, 2011.
- T. HOBIGER, H. TAKIGUCHI, R. ICHIKAWA, M. SEKIDO, Y. KOYAMA, T. KONDO: “Analysis

- Center at National Institute of Information and Communications Technology”. In: International VLBI Service for Geodesy and Astrometry 2010 Annual Report, edited by D. Behrend and K. Bayer, NASA/TP-2011-215880, 229–232, 2011.
- X. HONG, Q. FAN, B. XIA, T. AN: “Sheshan VLBI Station Report for 2010”. In: International VLBI Service for Geodesy and Astrometry 2010 Annual Report, edited by D. Behrend and K. Bayer, NASA/TP-2011-215880, 83–84, 2011.
- R. ICHIKAWA: “Preface”. IVS NICT Technology Development Center News, No. 32, ISSN 1882-3432, 1–4, November 2011.
- R. ICHIKAWA, E. KAWAI, M. SEKIDO: “Kashima 34-m Radio Telescope”. In: International VLBI Service for Geodesy and Astrometry 2010 Annual Report, edited by D. Behrend and K. Bayer, NASA/TP-2011-215880, 42–45, 2011.
- R. ICHIKAWA, M. KIMURA, M. SEKIDO: “VLBI Correlators in Kashima”. In: International VLBI Service for Geodesy and Astrometry 2010 Annual Report, edited by D. Behrend and K. Bayer, NASA/TP-2011-215880, 144–146, 2011.
- R. ICHIKAWA, H. TAKIGUCHI, M. SEKIDO, Y. KOYAMA: “Data Center at NICT”. In: International VLBI Service for Geodesy and Astrometry 2010 Annual Report, edited by D. Behrend and K. Bayer, NASA/TP-2011-215880, 163–166, 2011.
- G. ILIN: “Radio frequency interference at QUASAR Network Observatories”. In: Proceedings of the 20th Meeting of the European VLBI Group for Geodesy and Astrometry, edited by W. Alef, S. Bernhart, A. Nothnagel, Schriftenreihe des Instituts für Geodäsie und Geoinformation der Universität Bonn, Nr. 22, ISSN 1864-1113, 105–107, 2011.
- D. IVANOV, A. VYTNOV: “Experiment of Injecting Phase Cal ahead of the Feed: New Results”. In: Proceedings of the 20th Meeting of the European VLBI Group for Geodesy and Astrometry, edited by W. Alef, S. Bernhart, A. Nothnagel, Schriftenreihe des Instituts für Geodäsie und Geoinformation der Universität Bonn, Nr. 22, ISSN 1864-1113, 38–40, 2011.
- C. JACOBS: “JPL VLBI Analysis Center Report for 2010”. In: International VLBI Service for Geodesy and Astrometry 2010 Annual Report, edited by D. Behrend and K. Bayer, NASA/TP-2011-215880, 215–218, 2011.
- C. JACOBS, J. CLARK, L. SKJERVE, O. SOVERS, C. GARCÍA-MIRO, S. HORIUCHI: “The Celestial Reference Frame at X/Ka-band (8.4/32 GHz)”. In: Proceedings of the 20th Meeting of the European VLBI Group for Geodesy and Astrometry, edited by W. Alef, S. Bernhart, A. Nothnagel, Schriftenreihe des Instituts für Geodäsie und Geoinformation der Universität Bonn, Nr. 22, ISSN 1864-1113, 166–170, 2011.
- T. JIKE, S. MANABE, Y. TAMURA, M. SHIZUGAMI, VERA GROUP: “VERA Geodetic Activities”. In: International VLBI Service for Geodesy and Astrometry 2010 Annual Report, edited by D. Behrend and K. Bayer, NASA/TP-2011-215880, 60–63, 2011.
- P. KAUFMANN, A.M. PEREIRA DE LUCENA, A. SOMBRA DA SILVA: “Fortaleza Station: 2010 Status and Antenna Repair”. In: International VLBI Service for Geodesy and Astrometry 2010 Annual Report, edited by D. Behrend and K. Bayer, NASA/TP-2011-215880, 27–30, 2011.
- R. KAWABATA, S. KURIHARA, J. KURODA, M. ISHIHARA, K. KOKADO, R. ICHIKAWA, H. TAKIGUCHI, K. TAKEFUJI, M. KIMURA, Y. KOYAMA, A. ISHII, Y. MUKAI, K. NOZAWA, D. TANIMOTO: “Geodetic VLBI Observations by Compact Antennas”. IVS NICT Technology Development Center News, No. 32, ISSN 1882-3432, 26–27, November 2011.

- H. KIERULF: “NMA Analysis Center”. In: International VLBI Service for Geodesy and Astrometry 2010 Annual Report, edited by D. Behrend and K. Baver, NASA/TP-2011-215880, 233–235, 2011.
- K. KINGHAM, M. CARTER: “NEOS Operation Center”. In: International VLBI Service for Geodesy and Astrometry 2010 Annual Report, edited by D. Behrend and K. Baver, NASA/TP-2011-215880, 129–130, 2011.
- K. KINGHAM, D. HALL: “Washington Correlator”. In: International VLBI Service for Geodesy and Astrometry 2010 Annual Report, edited by D. Behrend and K. Baver, NASA/TP-2011-215880, 151–153, 2011.
- F. KIRSTEN, W. VLEMMINGS, M. KRAMER, P. FREIRE, H. VAN LANGEVELDE: “VLBI mapping of the globular cluster M15 – A pulsar proper motion analysis”. In: Proceedings of the 20th Meeting of the European VLBI Group for Geodesy and Astrometry, edited by W. Alef, S. Bernhart, A. Nothnagel, Schriftenreihe des Instituts für Geodäsie und Geoinformation der Universität Bonn, Nr. 22, ISSN 1864-1113, 108–111, 2011.
- K. KOKADO, S. KURIHARA, R. KAWABATA, K. NOZAWA: “Tsukuba VLBI Correlator”. In: International VLBI Service for Geodesy and Astrometry 2010 Annual Report, edited by D. Behrend and K. Baver, NASA/TP-2011-215880, 147–150, 2011.
- K. KOKADO, S. KURIHARA, R. KAWABATA, K. NOZAWA: “Tsukuba VLBI Analysis Center”. In: International VLBI Service for Geodesy and Astrometry 2010 Annual Report, edited by D. Behrend and K. Baver, NASA/TP-2011-215880, 253–256, 2011.
- K. KOKADO, S. KURIHARA, R. KAWABATA, K. NOZAWA, D. TANIMOTO: “Ultra-rapid dUT1 measurement with high-speed network”. IVS NICT Technology Development Center News, No. 32, ISSN 1882-3432, 28–31, November 2011.
- T. KONDO: “News – Success in an X-band VLBI using an RF direct sampling technique”. IVS NICT Technology Development Center News, No. 32, ISSN 1882-3432, 51, November 2011.
- S. KURDUBOV: “Estimation of Solar system acceleration from VLBI”. In: Proceedings of the 20th Meeting of the European VLBI Group for Geodesy and Astrometry, edited by W. Alef, S. Bernhart, A. Nothnagel, Schriftenreihe des Instituts für Geodäsie und Geoinformation der Universität Bonn, Nr. 22, ISSN 1864-1113, 112–113, 2011.
- S. KURIHARA: “VLBI2010 and GGOS”. IVS NICT Technology Development Center News, No. 32, ISSN 1882-3432, 40–41, November 2011.
- S. KURIHARA, K. KOKADO, R. KAWABATA, J. KURODA, M. ISHIHARA, D. TANIMOTO, Y. MUKAI: “Tsukuba 32-m VLBI Station”. In: International VLBI Service for Geodesy and Astrometry 2010 Annual Report, edited by D. Behrend and K. Baver, NASA/TP-2011-215880, 97–100, 2011.
- Y. KWAK, J. CHO: “KASI Combination Center Report”. In: International VLBI Service for Geodesy and Astrometry 2010 Annual Report, edited by D. Behrend and K. Baver, NASA/TP-2011-215880, 219–222, 2011.
- Y. KWAK, T. KONDO, T. GOTOH, J. AMAGAI, H. TAKIGUCHI, M. SEKIDO, R. ICHIKAWA, T. SASAO, J. CHO, T. KIM: “Validation Experiment of the GPS-VLBI Hybrid System”. In: Proceedings of the 20th Meeting of the European VLBI Group for Geodesy and Astrometry, edited by W. Alef, S. Bernhart, A. Nothnagel, Schriftenreihe des Instituts für Geodäsie und Geoinformation der Universität Bonn, Nr. 22, ISSN 1864-1113, 154–157, 2011.

- S. LAMBERT, C. BARACHE: “Paris Observatory Analysis Center OPAR: Report on Activities, January–December 2010”. In: International VLBI Service for Geodesy and Astrometry 2010 Annual Report, edited by D. Behrend and K. Baver, NASA/TP-2011-215880, 236–239, 2011.
- R. LANOTTE: “Matera CGS VLBI Analysis Center”. In: International VLBI Service for Geodesy and Astrometry 2010 Annual Report, edited by D. Behrend and K. Baver, NASA/TP-2011-215880, 187–188, 2011.
- K. LE BAIL, J. GIPSON: “Strategy to Improve the Homogeneity of Meteorological Data in Mark3 Databases”. In: Proceedings of the 20th Meeting of the European VLBI Group for Geodesy and Astrometry, edited by W. Alef, S. Bernhart, A. Nothnagel, Schriftenreihe des Instituts für Geodäsie und Geoinformation der Universität Bonn, Nr. 22, ISSN 1864-1113, 138–141, 2011.
- J. LOVELL, J. M. DICKEY, B. REID, S. ELLINGSEN, J. MCCALLUM: “Hobart, Mt. Pleasant Station and AuScope VLBI Project Report”. In: International VLBI Service for Geodesy and Astrometry 2010 Annual Report, edited by D. Behrend and K. Baver, NASA/TP-2011-215880, 39–41, 2011.
- S. LYTVYN, Y. YATSKIV: “IVS Analysis Center at Main Astronomical Observatory of National Academy of Sciences of Ukraine”. In: International VLBI Service for Geodesy and Astrometry 2010 Annual Report, edited by D. Behrend and K. Baver, NASA/TP-2011-215880, 227–228, 2011.
- D. MACMILLAN: “Assessing the Accuracy of Geodetic Measurements for the VLBI2010 Observing Network”. In: Proceedings of the 20th Meeting of the European VLBI Group for Geodesy and Astrometry, edited by W. Alef, S. Bernhart, A. Nothnagel, Schriftenreihe des Instituts für Geodäsie und Geoinformation der Universität Bonn, Nr. 22, ISSN 1864-1113, 74–77, 2011.
- Z. MALKIN: “Study of Astronomical and Geodetic Series using the Allan Variance”. *Kinematics Phys. Celest. Bodies*, 27(1), doi:10.3103/S0884591311010053, 42–49, 2011.
- Z. MALKIN: “The impact of celestial pole offset modelling on VLBI UT1 intensive results”. *Journal of Geodesy*, 85(9), doi:10.1007/s00190-011-0468-9, 617–622, 2011.
- Z. MALKIN: “The Influence of Galactic Aberration on Precession Parameters Determined from VLBI Observations”. *Astronomy Reports*, 55(9), doi:10.1134/S1063772911090058, 810–815, 2011.
- Z. MALKIN: “Pulkovo IVS Analysis Center (PUL) 2010 Annual Report”. In: International VLBI Service for Geodesy and Astrometry 2010 Annual Report, edited by D. Behrend and K. Baver, NASA/TP-2011-215880, 247–249, 2011.
- Z. MALKIN: “Comparison of CPO and FCN empirical models”. In: Proceedings of the ‘Journées 2010 Systèmes de Référence Spatio-temporels’, edited by N. Capitaine, Observatoire de Paris, 172–175, 2011.
- Z. MALKIN: “On computation of a common mean”. arXiv:1110.6639, 12 pp., 2011.
- Z. MALKIN, N. MILLER: “Amplitude and phase variations of the Chandler wobble from 164-yr polar motion series”. In: Proceedings of the ‘Journées 2010 Systèmes de Référence Spatio-temporels’, edited by N. Capitaine, Observatoire de Paris, 208–209, 2011.
- T. MIYAMURA, K. FUJISAWA, H. OGAWA, K. NOZAWA, K. KIMURA: “Development of a cooled low noise receiver at 22 GHz to be installed on Yamaguchi 32-m radio telescope”. *IVS NICT Technology Development Center News*, No. 32, ISSN 1882-3432, 22–23, November 2011.

- M. MIYOSHI, K. NIINUMA, Y. HAGIWARA, N. KAWAGUCHI, J. NAKAJIMA, Y. IRIMAJIRI, Y. KOYAMA, M. SEKIDO, H. UJIHARA, K. ISHITSUKAI, Y. ASAKI, Y. KATO, M. TSUBOI, T. KASUGA, A. TOMIMATSU, M. TAKAHASHI, Y. ERIGUCHI, S. YOSHIDA, S. KOIDE, R. TAKAHASHI, T. OKA: “A First Black Hole Imager at Andes”. IVS NICT Technology Development Center News, No. 32, ISSN 1882-3432, 38–39, November 2011.
- S. MÜHLE, R. CAMPBELL, A. SZOMORU: “Recent Developments at the Joint Institute for VLBI in Europe (JIVE)”. In: Proceedings of the 20th Meeting of the European VLBI Group for Geodesy and Astrometry, edited by W. Alef, S. Bernhart, A. Nothnagel, Schriftenreihe des Instituts für Geodäsie und Geoinformation der Universität Bonn, Nr. 22, ISSN 1864-1113, 52–56, 2011.
- V. NAFISI, M. MADZAK, J. BÖHM, H. SCHUH, A. ARDALAN: “Ray-traced tropospheric slant delays in VLBI analysis”. Österreichische Zeitschrift für Vermessung und Geoinformation (VGI), ISSN 1605-1653, Heft 2, 149–153, 2011.
- M. NEGUSINI, P. SARTI, C. ABBONDANZA: “Italy INAF Data Center Report”. In: International VLBI Service for Geodesy and Astrometry 2010 Annual Report, edited by D. Behrend and K. Bayer, NASA/TP-2011-215880, 162, 2011.
- M. NEGUSINI, P. SARTI, C. ABBONDANZA: “Italy INAF Analysis Center Report”. In: International VLBI Service for Geodesy and Astrometry 2010 Annual Report, edited by D. Behrend and K. Bayer, NASA/TP-2011-215880, 213–214, 2011.
- A. NEIDHARDT, M. Ettl, H. ROTTMANN, C. PLÖTZ, M. MÜHLBAUER, H. HASE, W. ALEF, S. SOBARZO, C. HERRERA, C. BEAUDOIN, E. HIMWICH: “New technical observation strategies with e-control (new name: e-RemoteCtrl)”. In: Proceedings of the 20th Meeting of the European VLBI Group for Geodesy and Astrometry, edited by W. Alef, S. Bernhart, A. Nothnagel, Schriftenreihe des Instituts für Geodäsie und Geoinformation der Universität Bonn, Nr. 22, ISSN 1864-1113, 26–30, 2011.
- A. NEIDHARDT, G. KRONSNABL, T. KLÜGEL, H. HASE, K. PAUSCH, W. GÖLDI, VLBI TEAM WETTZELL: “VLBI2010 – Current status of the TWIN radio telescope project at Wettzell, Germany”. In: Proceedings of the 20th Meeting of the European VLBI Group for Geodesy and Astrometry, edited by W. Alef, S. Bernhart, A. Nothnagel, Schriftenreihe des Instituts für Geodäsie und Geoinformation der Universität Bonn, Nr. 22, ISSN 1864-1113, 67–70, 2011.
- A. NEIDHARDT, G. KRONSNABL, R. SCHATZ: “Geodetic Observatory Wettzell: 20-m Radio Telescope and Twin Telescope”. In: International VLBI Service for Geodesy and Astrometry 2010 Annual Report, edited by D. Behrend and K. Bayer, NASA/TP-2011-215880, 113–116, 2011.
- A. NIELL: “Haystack Observatory Analysis Center”. In: International VLBI Service for Geodesy and Astrometry 2010 Annual Report, edited by D. Behrend and K. Bayer, NASA/TP-2011-215880, 202–204, 2011.
- C. NIELSEN: “Ny-Ålesund 20-meter Antenna”. In: International VLBI Service for Geodesy and Astrometry 2010 Annual Report, edited by D. Behrend and K. Bayer, NASA/TP-2011-215880, 68–70, 2011.
- T. NILSSON, J. BÖHM, S. BÖHM, M. MADZAK, V. NAFISI, L. PLANK, H. SPICAKOVA, J. SUN, C. TIERNO ROS, H. SCHUH: “Status and future plans for the Vienna VLBI Software VieVS”. In: Proceedings of the 20th Meeting of the European VLBI Group for Geodesy and Astrometry, edited by W. Alef, S. Bernhart, A. Nothnagel, Schriftenreihe des Instituts für Geodäsie und

- Geoinformation der Universität Bonn, Nr. 22, ISSN 1864-1113, 93–96, 2011.
- T. NILSSON, J. BÖHM, H. SCHUH: “Universal time from VLBI single-baseline observations during CONT08”. *Journal of Geodesy*, 85(7), doi:10.1007/s00190-010-0436-9, 415–423, 2011.
- T. NILSSON, J. BÖHM, H. SCHUH: “Impacts of the 2010 Chile Earthquake on Earth rotation”. In: Proceedings of the ‘Journées 2010 Systèmes de Référence Spatio-temporels’, edited by N. Capitaine, Observatoire de Paris, 176–179, 2011.
- C. NOLL: “CDDIS Data Center Summary for the IVS 2010 Annual Report”. In: International VLBI Service for Geodesy and Astrometry 2010 Annual Report, edited by D. Behrend and K. Baver, NASA/TP-2011-215880, 159–161, 2011.
- E. NOSOV: “Next-Generation DAS for the Russian VLBI-Network”. In: Proceedings of the 20th Meeting of the European VLBI Group for Geodesy and Astrometry, edited by W. Alef, S. Bernhart, A. Nothnagel, Schriftenreihe des Instituts für Geodäsie und Geoinformation der Universität Bonn, Nr. 22, ISSN 1864-1113, 41–43, 2011.
- A. NOTHNAGEL, A. MÜSKENS: “The Bonn Geodetic VLBI Operation Center”. In: International VLBI Service for Geodesy and Astrometry 2010 Annual Report, edited by D. Behrend and K. Baver, NASA/TP-2011-215880, 123–124, 2011.
- A. NOTHNAGEL, S. TESMER NÉE BÖCKMANN, T. ARTZ: “Analysis Coordinator Report”. In: International VLBI Service for Geodesy and Astrometry 2010 Annual Report, edited by D. Behrend and K. Baver, NASA/TP-2011-215880, 16–17, 2011.
- A. ORFEI, A. ORLATI, G. MACCAFERRI, F. MANTOVANI: “The Medicina Station Status Report”. In: International VLBI Service for Geodesy and Astrometry 2010 Annual Report, edited by D. Behrend and K. Baver, NASA/TP-2011-215880, 58–59, 2011.
- T. OTSUBO, T. HOBIGER, T. GOTOH, T. KUBO-OKA, M. SEKIDO, H. TAKIGUCHI, H. TAKEUCHI: “Software ‘c5++’ for Combined Space-Geodetic Analysis”. *IVS NICT Technology Development Center News*, No. 32, ISSN 1882-3432, 5–6, November 2011.
- M. PANTALEEV, R. HAAS, L. HELLDNER, L. PETTERSSON, K. JOHANSSON, B. KLEIN: “Onsala Space Observatory – IVS Technology Development Center”. In: International VLBI Service for Geodesy and Astrometry 2010 Annual Report, edited by D. Behrend and K. Baver, NASA/TP-2011-215880, 280–283, 2011.
- A. PANY, J. BÖHM, D. MACMILLAN, H. SCHUH, T. NILSSON, J. WRESNIK: “Monte Carlo simulations of the impact of troposphere, clock and measurement errors on the repeatability of VLBI positions”. *Journal of Geodesy*, 85(1), doi:10.1007/s00190-010-0415-1, 39–50, 2011.
- B. PETRACHENKO: “Canadian VLBI Technology Development Center”. In: International VLBI Service for Geodesy and Astrometry 2010 Annual Report, edited by D. Behrend and K. Baver, NASA/TP-2011-215880, 267, 2011.
- J. PIETZNER, A. NOTHNAGEL: “Geodetic VLBI Intensive Scheduling based on Singular Value Decomposition”. In: Proceedings of the 20th Meeting of the European VLBI Group for Geodesy and Astrometry, edited by W. Alef, S. Bernhart, A. Nothnagel, Schriftenreihe des Instituts für Geodäsie und Geoinformation der Universität Bonn, Nr. 22, ISSN 1864-1113, 9–13, 2011.
- L. PLANK, J. BÖHM, H. SCHUH: “First steps of processing VLBI data of space probes with VieVS”. In: Proceedings of the 20th Meeting of the European VLBI Group for Geodesy and Astrometry, edited by W. Alef, S. Bernhart, A. Nothnagel, Schriftenreihe des Instituts für



- Geodäsie und Geoinformation der Universität Bonn, Nr. 22, ISSN 1864-1113, 60–63, 2011.
- C. PLÖTZ, R. WOJZIAK, A. NEIDHARDT: “German Antarctic Receiving Station (GARS) OHiggins”. In: International VLBI Service for Geodesy and Astrometry 2010 Annual Report, edited by D. Behrend and K. Baver, NASA/TP-2011-215880, 71–74, 2011.
- M. POIRIER: “Westford Antenna”. In: International VLBI Service for Geodesy and Astrometry 2010 Annual Report, edited by D. Behrend and K. Baver, NASA/TP-2011-215880, 109–112, 2011.
- J. REDMOND, I. DIEGEL: “Goddard Geophysical and Astronomical Observatory”. In: International VLBI Service for Geodesy and Astrometry 2010 Annual Report, edited by D. Behrend and K. Baver, NASA/TP-2011-215880, 31–34, 2011.
- J. REYNOLDS, T. TZIOUMIS: “Parkes 2010 IVS Report”. In: International VLBI Service for Geodesy and Astrometry 2010 Annual Report, edited by D. Behrend and K. Baver, NASA/TP-2011-215880, 79–82, 2011.
- M. ROTHACHER, D. ANGERMANN, T. ARTZ, W. BOSCH, H. DREWES, M. GERSTL, R. KELM, D. KÖNIG, R. KÖNIG, B. MEISEL, H. MÜLLER, A. NOTHNAGEL, N. PANAFIDINA, B. RICHTER, S. RUDENKO, W. SCHWEGMANN, M. SEITZ, P. STEIGENBERGER, S. TESMER, V. TESMER, D. THALLER: “GGOS-D: Homogeneous reprocessing and rigorous combination of space geodetic observations”. *Journal of Geodesy*, 85(10), doi:10.1007/s00190-011-0475-x, 679–705, 2011.
- A. SANTAMARÍA-GÓMEZ, S. GARCÍA-ESPADA: “Simulating the estimation of the 40-m radio-telescope Invariant Reference Point at the Yebes Observatory”. Informe Técnico OAN 2011-9, 23 pp., 2011.  
<http://www1.oan.es/informes/archivos/IT-OAN-2011-9.pdf>
- P. SARTI, C. ABBONDANZA, L. PETROV, M. NEGUSINI: “Height bias and scale effect induced by antenna gravity deformations in geodetic VLBI data analysis”. *Journal of Geodesy*, 85(1), doi:10.1007/s00190-010-0410-6, 1–8, 2011.
- M. SCHINDELEGGER, J. BÖHM, D. SALSTEIN, H. SCHUH: “High-resolution atmospheric angular momentum functions related to Earth rotation parameters during CONT08”. *Journal of Geodesy*, 85(7), doi:10.1007/s00190-011-0458-y, 425–433, 2011.
- H. SCHUH, J. BÖHM, S. BÖHM, V. NAFISI, T. NILSSON, A. PANY, L. PLANK, H. SPICAKOVA, J. SUN, K. TEKE, C. TIerno ROS: “Vienna IGG Special Analysis Center Annual Report 2010”. In: International VLBI Service for Geodesy and Astrometry 2010 Annual Report, edited by D. Behrend and K. Baver, NASA/TP-2011-215880, 209–212, 2011.
- M. SEITZ, R. HEINKELMANN, P. STEIGENBERGER, T. ARTZ: “Common Realization of Terrestrial and Celestial Reference Frame”. In: Proceedings of the 20th Meeting of the European VLBI Group for Geodesy and Astrometry, edited by W. Alef, S. Bernhart, A. Nothnagel, Schriftenreihe des Instituts für Geodäsie und Geoinformation der Universität Bonn, Nr. 22, ISSN 1864-1113, 123–127, 2011.
- E. SKURIKHINA, S. KURDUBOV, V. GUBANOV: “IAA VLBI Analysis Center Report 2010”. In: International VLBI Service for Geodesy and Astrometry 2010 Annual Report, edited by D. Behrend and K. Baver, NASA/TP-2011-215880, 205–208, 2011.
- S. SOBARZO, E. OÑATE, C. HERRERA, P. ZAROR, F. PEDREROS, O. ZAPATA, H. HASE: “Geodetic Observatory TIGO in Concepción”. In: International VLBI Service for Geodesy and

- Astrometry 2010 Annual Report, edited by D. Behrend and K. Baver, NASA/TP-2011-215880, 93–96, 2011.
- H. SPICAKOVA, L. PLANK, T. NILSSON J. BÖHM, H. SCHUH: “Terrestrial reference frame solution with the Vienna VLBI Software VieVS and implication of tropospheric gradient estimation”. In: Proceedings of the 20th Meeting of the European VLBI Group for Geodesy and Astrometry, edited by W. Alef, S. Bernhart, A. Nothnagel, Schriftenreihe des Instituts für Geodäsie und Geoinformation der Universität Bonn, Nr. 22, ISSN 1864-1113, 118–122, 2011.
- J. SUN, A. PANY, T. NILSSON, J. BÖHM, H. SCHUH: “Status and future plans for the VieVS scheduling package”. In: Proceedings of the 20th Meeting of the European VLBI Group for Geodesy and Astrometry, edited by W. Alef, S. Bernhart, A. Nothnagel, Schriftenreihe des Instituts für Geodäsie und Geoinformation der Universität Bonn, Nr. 22, ISSN 1864-1113, 44–48, 2011.
- I. SURKIS, V. KEN, A. MELNIKOV, V. MISHIN, V. SHANTYR, V. ZIMOVSKY: “IAA Correlator Center”. In: International VLBI Service for Geodesy and Astrometry 2010 Annual Report, edited by D. Behrend and K. Baver, NASA/TP-2011-215880, 141–143, 2011.
- F. TAKAHASHI, T. SHINNO, M. UCHIDA, K. SHIOZAWAI, T. YANAGI, T. KATAYAMA, T. KAJIWARA: “Major Results of Medical ICT Experiments using Space Technology –WINDS VSAT, Interferometer, VLBI and QZS–”. IVS NICT Technology Development Center News, No. 32, ISSN 1882-3432, 42–50, November 2011.
- K. TAKEFUJI, T. KONDO, H. TAKIGUCHI: “Technology Development Center at NICT”. In: International VLBI Service for Geodesy and Astrometry 2010 Annual Report, edited by D. Behrend and K. Baver, NASA/TP-2011-215880, 276–279, 2011.
- K. TAKEFUJI, M. TSUTSUMI, Y. MIYAUCHI, R. ICHIKAWA, Y. KOYAMA: “Estimation of WiFi instruments with DoREMI system (Distribution of Radio Emission Measurement Interferometer)”. IVS NICT Technology Development Center News, No. 32, ISSN 1882-3432, 15–19, November 2011.
- H. TAKIGUCHI, R. ICHIKAWA: “Kashima and Koganei 11-m VLBI Stations”. In: International VLBI Service for Geodesy and Astrometry 2010 Annual Report, edited by D. Behrend and K. Baver, NASA/TP-2011-215880, 46–49, 2011.
- H. TAKIGUCHI, M. KIMURA, T. KONDO, A. ISHII, T. HOBIGER, R. ICHIKAWA, Y. KOYAMA, Y. TAKAHASHI, F. NAKAGAWA, M. NAKAMURA, R. TABUCHI, S. TSUTSHIYA, S. HAMA, T. GOTOH, M. FUJIEDA, M. AIDA, T. LI, J. AMAGAI: “Inter-comparison Study of Time and Frequency Transfer between VLBI and Other Techniques”. IVS NICT Technology Development Center News, No. 32, ISSN 1882-3432, 32–37, November 2011.
- E. TANÍR, K. TEKE: “KTU-GEOD IVS Analysis Center Annual Report 2010”. In: International VLBI Service for Geodesy and Astrometry 2010 Annual Report, edited by D. Behrend and K. Baver, NASA/TP-2011-215880, 223–226, 2011.
- K. TEKE, J. BÖHM, T. NILSSON, H. SCHUH, P. STEIGENBERGER, R. DACH, R. HEINKELMANN, P. WILLIS, R. HAAS, S. GARCÍA-ESPADA, T. HOBIGER, R. ICHIKAWA, S. SHIMIZU: “Multi-technique comparison of troposphere zenith delays and gradients during CONT08”. *Journal of Geodesy*, 85(7), doi:10.1007/s00190-010-0434-y, 395–413, 2011.
- F. TERCERO, J. SERNA, T. FINN, J. LÓPEZ FERNÁNDEZ: “The CDT Ultra Wide-Band Anechoic Chamber”. *Informe Técnico OAN 2011-13*, 15 pp., 2011.

- <http://www1.oan.es/informes/archivos/IT-OAN-2011-13.pdf>
- C. THOMAS, D. MACMILLAN: “CORE Operation Center Report”. In: International VLBI Service for Geodesy and Astrometry 2010 Annual Report, edited by D. Behrend and K. Bayer, NASA/TP-2011-215880, 125–128, 2011.
- V. THORANDT, A. NOTHNAGEL, G. ENGELHARDT, D. ULLRICH, T. ARTZ, S. TESMER NÉE BÖCKMANN, J. PIETZNER: “The BKG/IGGB VLBI Analysis Center”. In: International VLBI Service for Geodesy and Astrometry 2010 Annual Report, edited by D. Behrend and K. Bayer, NASA/TP-2011-215880, 194–197, 2011.
- V. THORANDT, R. WOJDZIAK: “BKG Data Center”. In: International VLBI Service for Geodesy and Astrometry 2010 Annual Report, edited by D. Behrend and K. Bayer, NASA/TP-2011-215880, 157–158, 2011.
- C. TIerno ROS, J. BÖHM, H. SCHUH: “Use of GNSS-derived TEC maps for VLBI observations”. In: Proceedings of the 20th Meeting of the European VLBI Group for Geodesy and Astrometry, edited by W. Alef, S. Bernhart, A. Nothnagel, Schriftenreihe des Instituts für Geodäsie und Geoinformation der Universität Bonn, Nr. 22, ISSN 1864-1113, 114–117, 2011.
- O. TITOV: “Geoscience Australia Analysis Center”. In: International VLBI Service for Geodesy and Astrometry 2010 Annual Report, edited by D. Behrend and K. Bayer, NASA/TP-2011-215880, 175–178, 2011.
- O. TITOV, D. JAUNCEY, H. JOHNSTON, R. HUNSTEAD, L. CHRISTENSEN: “Optical spectra of southern flat-spectrum IVS radio sources”. In: Proceedings of the 20th Meeting of the European VLBI Group for Geodesy and Astrometry, edited by W. Alef, S. Bernhart, A. Nothnagel, Schriftenreihe des Instituts für Geodäsie und Geoinformation der Universität Bonn, Nr. 22, ISSN 1864-1113, 174–177, 2011.
- O. TITOV, S. LAMBERT: “The first VLBI detection of the secular aberration drift”. In: Proceedings of the 20th Meeting of the European VLBI Group for Geodesy and Astrometry, edited by W. Alef, S. Bernhart, A. Nothnagel, Schriftenreihe des Instituts für Geodäsie und Geoinformation der Universität Bonn, Nr. 22, ISSN 1864-1113, 171–173, 2011.
- M. TITUS, R. CAPPALLO, B. COREY, K. DUDEVOIR, A. NIELL, A. WHITNEY: “Haystack Observatory VLBI Correlator”. In: International VLBI Service for Geodesy and Astrometry 2010 Annual Report, edited by D. Behrend and K. Bayer, NASA/TP-2011-215880, 137–140, 2011.
- V. TORNATORE: “New Associate Analysis Center Established at PMD”. In: International VLBI Service for Geodesy and Astrometry 2010 Annual Report, edited by D. Behrend and K. Bayer, NASA/TP-2011-215880, 244–246, 2011.
- V. TORNATORE, R. HAAS, D. DUEV, S. POGREBENKO, S. CASEY, G. MOLERA CALVÉS, A. KEIMPEMA: “Single baseline GLONASS observations with VLBI: data processing and first results”. In: Proceedings of the 20th Meeting of the European VLBI Group for Geodesy and Astrometry, edited by W. Alef, S. Bernhart, A. Nothnagel, Schriftenreihe des Instituts für Geodäsie und Geoinformation der Universität Bonn, Nr. 22, ISSN 1864-1113, 162–165, 2011.
- D. TROFIMOV, V. VITYAZEV: “Analysis Center of Saint Petersburg University”. In: International VLBI Service for Geodesy and Astrometry 2010 Annual Report, edited by D. Behrend and K. Bayer, NASA/TP-2011-215880, 173–174, 2011.
- G. TUCCARI: “Noto Station Status Report”. In: International VLBI Service for Geodesy and

- Astrometry 2010 Annual Report, edited by D. Behrend and K. Baver, NASA/TP-2011-215880, 64–67, 2011.
- G. TUCCARI: “DBBC3”. In: Proceedings of the 20th Meeting of the European VLBI Group for Geodesy and Astrometry, edited by W. Alef, S. Bernhart, A. Nothnagel, Schriftenreihe des Instituts für Geodäsie und Geoinformation der Universität Bonn, Nr. 22, ISSN 1864-1113, 19–21, 2011.
- H. UJIHARA, K. TAKEFUJI, M. SEKIDO, R. ICHIKAWA, Y. KOYAMA: “Development of Weak Radiation Power Measurement Technique”. IVS NICT Technology Development Center News, No. 32, ISSN 1882-3432, 11–14, November 2011.
- A. VOLVACH, A. DMITROTSIA, V. ANDREATTA: “Stations of Space Geodesy and Geodynamics of CrAO: Simeiz VLBI, Simeiz-1873 SLR, CrAO-GPS”. In: International VLBI Service for Geodesy and Astrometry 2010 Annual Report, edited by D. Behrend and K. Baver, NASA/TP-2011-215880, 85–88, 2011.
- G. WANG, J. LI, M. XU, L. GUO, F. SHU, Z. QIAN, B. ZHANG: “SHAO Analysis Center 2010 Annual Report”. In: International VLBI Service for Geodesy and Astrometry 2010 Annual Report, edited by D. Behrend and K. Baver, NASA/TP-2011-215880, 252, 2011.
- A. WHITNEY: “IVS Technology Coordination Report”. In: International VLBI Service for Geodesy and Astrometry 2010 Annual Report, edited by D. Behrend and K. Baver, NASA/TP-2011-215880, 21–24, 2011.
- A. WHITNEY, D. LAPSLEY, M. TAVENIKU: “Mark 6: A Next-Generation VLBI Data System”. In: Proceedings of the 20th Meeting of the European VLBI Group for Geodesy and Astrometry, edited by W. Alef, S. Bernhart, A. Nothnagel, Schriftenreihe des Instituts für Geodäsie und Geoinformation der Universität Bonn, Nr. 22, ISSN 1864-1113, 31–34, 2011.
- H. WIESEMAYER, A. NOTHNAGEL: “Very Long Baseline Interferometry”. Encyclopedia of Solid Earth Geophysics, Encyclopedia of Earth Sciences Series, Part 18, doi:10.1007/978-90-481-8702-7\_99, 1509–1515, 2011.
- Y. YONEKURA: “Present Status of Ibaraki station (Takahagi and Hitachi 32-m Radio Telescopes)”. IVS NICT Technology Development Center News, No. 32, ISSN 1882-3432, 24–25, November 2011.
- A. YUSUP, X. LIU: “Nanshan VLBI Station Report for 2010”. In: International VLBI Service for Geodesy and Astrometry 2010 Annual Report, edited by D. Behrend and K. Baver, NASA/TP-2011-215880, 101–104, 2011.
- V. ZHAROV, M. KAUFMAN: “SAI VLBI Analysis Center Report 2010”. In: International VLBI Service for Geodesy and Astrometry 2010 Annual Report, edited by D. Behrend and K. Baver, NASA/TP-2011-215880, 250–251, 2011.
- N. ZUBKO, M. POUTANEN: “Crustal movements in Europe observed with EUROPE and IVS-T2 VLBI networks”. In: Proceedings of the 20th Meeting of the European VLBI Group for Geodesy and Astrometry, edited by W. Alef, S. Bernhart, A. Nothnagel, Schriftenreihe des Instituts für Geodäsie und Geoinformation der Universität Bonn, Nr. 22, ISSN 1864-1113, 150–153, 2011.

# IVS Information

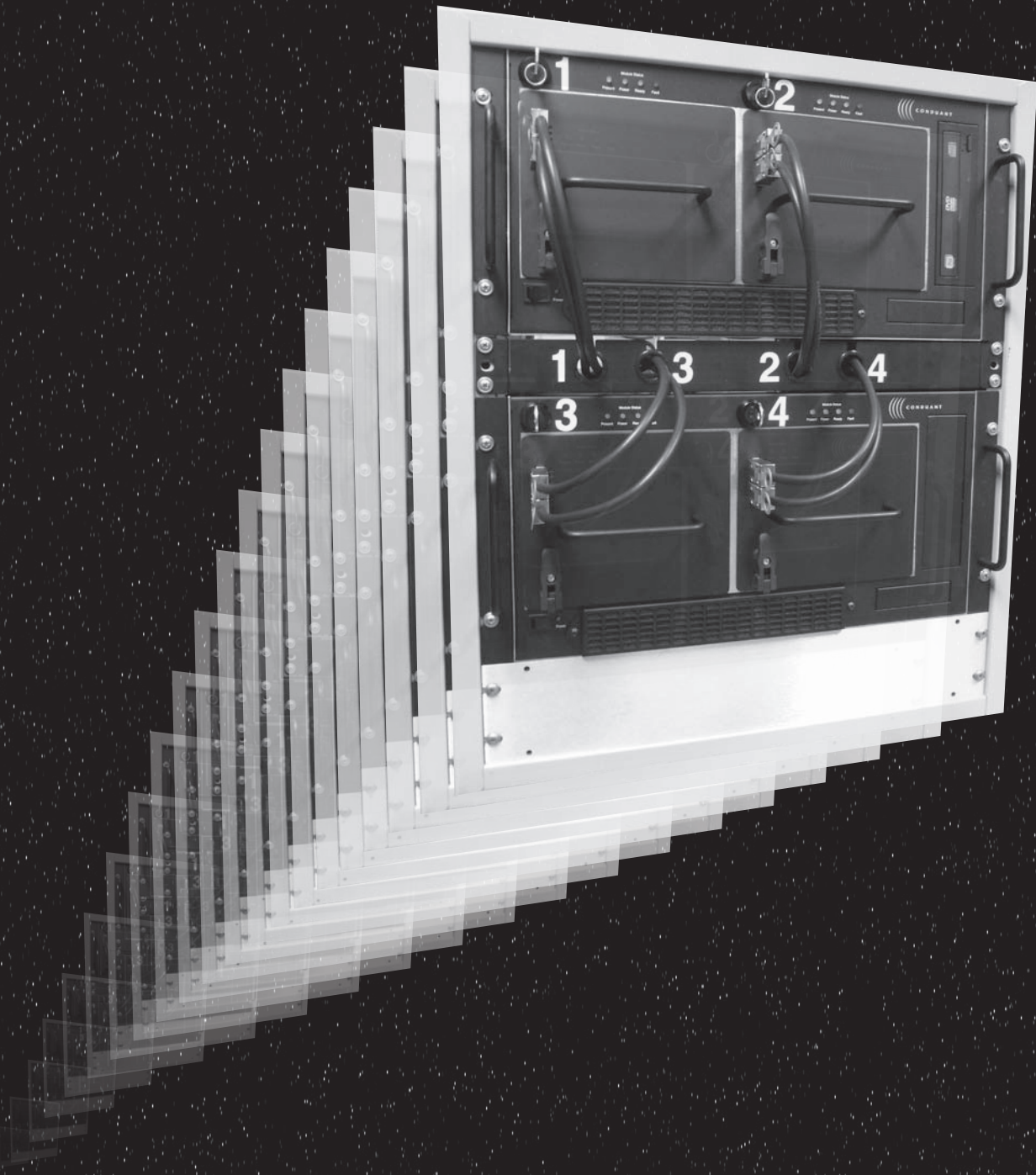

# IVS Information



---

## IVS Terms of Reference

### 1. Summary

#### 1.1. Charter

The International VLBI Service for Geodesy and Astrometry (IVS) is an international collaboration of organizations which operate or support Very Long Baseline Interferometry (VLBI) components. IVS provides a service which supports geodetic and astrometric work on reference systems, Earth science research, and operational activities. IVS is a Service of the International Association of Geodesy (IAG) and of the International Astronomical Union (IAU).

#### 1.2. Objectives

IVS fulfills its charter through the following objectives.

1. foster and carry out VLBI programs. This is accomplished through close coordination of the participating organizations to provide high-quality VLBI data and products.
2. promote research and development activities in all aspects of the geodetic and astrometric VLBI technique.
3. advance the education and training of VLBI participants through workshops, reports, and other means.
4. support the integration of new components into IVS.
5. interact with the community of users of VLBI products. IVS represents VLBI in the Global Geodetic Observing System (GGOS) of the IAG and interacts closely with the International Earth Rotation and Reference Systems Service (IERS).

In support of these objectives, IVS coordinates VLBI observing programs, sets performance standards for VLBI stations, establishes conventions for VLBI data formats and data products, issues recommendations for VLBI data analysis software, sets standards for VLBI analysis documentation, and institutes appropriate VLBI product delivery methods to ensure suitable product quality and timeliness. IVS coordinates its activities with the astronomical community because of the dual use of many VLBI facilities and technologies for both astronomy and astrometry/geodesy.

#### 1.3. Data Products

VLBI data products contribute uniquely to these important activities:

- defining and maintaining the celestial reference frame,
- monitoring universal time (UT1),
- monitoring the coordinates of the celestial pole (nutations and precession).

These results are the foundation of many scientific and practical applications requiring the use of an accurate quasi-inertial reference frame, such as high-precision positioning, navigation, and timing. In addition IVS provides a variety of VLBI products with differing applications, timeliness, detail, and temporal resolution, such as:

- all components of Earth orientation parameters,
- terrestrial reference frame,
- baseline lengths,
- tropospheric parameters.

All VLBI data and products are publicly available in appropriate formats from IVS Data Centers.

#### **1.4. Research**

The IVS data and products are used for research in many areas of geodesy, geophysics, and astronomy, such as:

- UT1 and polar motion excitation over periods of hours to decades,
- solid Earth interior research (e.g., mantle rheology, anelasticity, libration, core modes),
- characterization of celestial reference frame sources and improvements to the frame,
- tidal variations (solid Earth, oceanic, and atmospheric),
- improvements in the terrestrial reference frame, especially in the scale,
- climate studies (e.g., sea level change, deglaciation, water vapor),
- regional and global geodynamics,
- general relativity.

To support these activities, there are ongoing research efforts to improve and extend the VLBI technique in areas such as:

- instrumentation, data acquisition, and correlation,
- data analysis techniques,
- spacecraft tracking and navigation (Earth-orbiting and interplanetary)
- combination of VLBI data and results with other techniques.

## **2. Permanent Components**

IVS acquires, correlates, and analyzes VLBI data to produce geodetic, astrometric, and other results that are archived and publicized. IVS accomplishes its objectives through the following permanent components:

- Network Stations,
- Operation Centers,
- Correlators,
- Analysis Centers,
- Data Centers,
- Technology Development Centers,
- Coordinating Center.



## 2.1. Network Stations

The IVS observing network consists of high performance VLBI stations.

- Stations may either be dedicated to geodesy or have multiple uses (including astronomical observations or satellite tracking applications).
- Stations comply with performance standards for data quality and operational reliability specified by the Directing Board.
- Stations provide local tie information, timing and meteorological data to the IVS Data Centers.
- VLBI data acquisition sessions are conducted by groups of Network Stations that may be distributed either globally or over a geographical region.

## 2.2. Operation Centers

The IVS Operation Centers coordinate the routine operations of specific networks. Operation Center activities include:

- planning network observing programs,
- supporting the network stations in improving their performance,
- generating the detailed observing schedules for use in data acquisition sessions by IVS Network Stations, item posting the observing schedule to an IVS Data Center for distribution and archiving.

IVS Operation Centers follow guidelines from the Coordinating Center for timeliness and schedule file formats.

## 2.3. Correlators

The IVS Correlators process raw VLBI data. Their other tasks are to:

- provide timely feedback to the Network Stations about data quality,
- jointly maintain the geodetic/astrometric community's media pool and transport,
- manage electronic data transfer,
- make processed data available to the Data Centers,
- regularly compare processing techniques, models, and outputs to ensure that data from different Correlators are identical.

## 2.4. Analysis Centers

The IVS coordinates VLBI data analysis to provide high-quality products for its users. The analyses are performed by

- Operational Analysis Center,
- Associate Analysis Centers,

- Special Analysis Centers for Specific Observing Sessions, and
- Combination Centers

All Analysis Centers maintain and/or develop appropriate VLBI analysis software.

Operational Analysis Centers are committed to producing results to the specifications of the IVS Analysis Coordinator and always on schedule to meet IVS requirements. In addition, Operational Analysis Centers may produce Earth orientation parameters, station coordinates, and source positions in regular intervals.

Operational Analysis Centers place their final results in IVS Data Centers for dissemination to researchers and other users. They adhere to IVS recommendations for the creation of high-quality products and their timely archiving and distribution. Any deviations that an Operational Analysis Center makes from IVS recommendations are properly documented. Operational Analysis Centers provide timely feedback about station performance. In addition to these regular services, Operational Analysis Centers may also perform any task of an Associate Analysis Center.

Associate Analysis Centers are committed to regularly submit specialized products using complete series or subsets of VLBI observing sessions. The analysis is performed for specific purposes as recognized by the Directing Board, such as exploitation of VLBI data for new types of results, investigations of regional phenomena, reference frame maintenance, or special determinations of Earth orientation parameters. The Associate Analysis Centers place their final results in IVS Data Centers for dissemination to researchers and other users. They adhere to IVS recommendations for the creation of high-quality products and their timely archiving and distribution. Any deviations that an Associate Analysis Center makes from IVS recommendations are properly documented.

Special Analysis Centers for Specific Observing Sessions have responsibility for ongoing series-related investigations of one or more existing session types. They perform detailed and comparative analyses of each session of a series within a reasonable time after correlation. In addition, they report deficits and technical complications to the observing sites, the correlators, and to the schedulers as well as to the IVS Network and Analysis Coordinators.

Combination Centers are committed to produce combination results from the individual submissions of the Operational Analysis Centers as official IVS products. For this purpose they monitor the quality of the submissions. The official IVS products include, but are not limited to, EOP time series derived from session-based results for 24-hour network sessions and 1-hour Intensive sessions. Combination Centers also contribute to the generation of the official IVS input to International Terrestrial Reference Frame (ITRF) computations. The combination work is done in a timely fashion and in close cooperation with the IVS Analysis Coordinator.

## 2.5. Data Centers

The IVS Data Centers are repositories for VLBI observing schedules, station log files, data and products. Data Centers may mirror other Data Centers to make the distribution and maintenance of data more efficient and reliable.

- Data Centers are the primary means of distributing VLBI products to users.
- Data Centers work closely with the Coordinating Center and with the Analysis Centers to ensure that all the information and data required by IVS components are quickly and reliably available.

Data Centers provide the following functions:

- receive and archive schedule files from Operation Centers,
- receive and archive log files and ancillary data files from the Network Stations,
- receive and archive data products from the Analysis Centers,
- provide access and public availability to IVS data products for all users.

## 2.6. Technology Development Centers

The IVS Technology Development Centers contribute to the development of new VLBI technology for improvement of the VLBI technique. They:

- investigate new equipment and approaches,
- develop, test, and document new hardware, firmware, and software for operations,
- assist with deployment, installation, and training for any new approved technology,
- maintain and support operational equipment.

## 2.7. Coordinating Center

The IVS Coordinating Center is responsible for coordination of both the day-to-day and the long-term activities of IVS, consistent with the directives and policies established by the Directing Board. Specifically, the Coordinating Center monitors, coordinates, and supports the activities of the Network Stations, Operation Centers, Correlators, Data Centers, Analysis Centers, and Technology Development Centers. The Coordinating Center works closely with the Technology Coordinator, the Network Coordinator, and the Analysis Coordinator to coordinate IVS activities.

The primary functions of the Coordinating Center are to:

- coordinate observing programs approved by the Directing Board,
- create and maintain the master schedule of observing sessions in coordination with IVS Network Stations and astronomical observing programs,
- foster communications among all components of the IVS,
- coordinate the best use of community resources,
- develop standard procedures for IVS components,
- organize training in VLBI techniques,
- organize workshops and meetings, including IVS technical meetings,
- produce and publish reports of activities of IVS components,
- maintain the IVS information system and archive all documents, standards, specifications, manuals, reports, and publications,
- coordinate IVS outreach and educational activities,
- provide liaison with the IAU, IAG, GGOS, IERS, and other organizations,
- provide the Secretariat of the Directing Board.

## 2.8. Becoming a Permanent Component

IVS will accept proposals at any time to become a permanent component. Such proposals will be reviewed for approval by the Directing Board.

## 3. Coordinators

Specific IVS activities regarding network data quality, products, and technology are accomplished through the functions performed by three coordinators: a Network Coordinator, an Analysis Coordinator, and a Technology Coordinator.

### 3.1. Network Coordinator

The IVS Network Coordinator is selected by the Directing Board from responses to an open solicitation to all IVS components. The Network Coordinator represents the IVS Network Stations on the Directing Board and works closely with the Coordinating Center. The Network Coordinator is responsible for stimulating the maintenance of a high quality level in the station operation and data delivery. The Network Coordinator performs the following functions:

- monitors adherence to standards in the network operation,
- participates in the quality control of the data acquisition performance of the network stations,
- tracks data quality and data flow problems and suggests actions to improve the level of performance,
- coordinates software development for station control and monitoring.

The Network Coordinator works closely with the geodetic and astronomical communities who are using the same network stations for observations. The Network Coordinator takes a leading role in ensuring the visibility and representation of the network stations.

### 3.2. Analysis Coordinator

The IVS Analysis Coordinator is selected by the Directing Board from responses to an open solicitation to the IVS Analysis Centers. The Analysis Coordinator is responsible for coordinating the analysis activities of IVS and for stimulating VLBI product development and delivery. The Analysis Coordinator performs the following functions:

- fosters comparisons of results from different VLBI analysis software packages and different analysis strategies,
- encourages documentation of analysis and combination software,
- participates in comparisons of results from different space geodetic techniques,
- monitors Analysis Centers' products for high quality results and for adherence to IVS standards and IERS Conventions,
- ensures that IVS analysis and combination products are archived and are available to the scientific community, and
- supervises the formation of the official IVS products specified by the IVS Directing Board.

The Analysis Coordinator plays a leadership role in the development of methods for generation and distribution of VLBI products so that the products reach the users in a timely manner. The Analysis Coordinator interacts with GGOS and the IERS and promotes the use of VLBI products by the broader scientific community. The Analysis Coordinator works closely with the astronomical communities who are using some of the same analysis methods and software.

### **3.3. Technology Coordinator**

The IVS Technology Coordinator is selected by the Directing Board from responses to an open solicitation to the IVS Technology Development Centers. The Technology Coordinator performs the following functions:

- stimulates advancement of the VLBI technique,
- maintains awareness of all current VLBI technologies and ongoing development,
- coordinates development of new technology among all IVS Technology Development Centers,
- encourages technical compatibility with the astronomical community,
- encourages and oversees development of VLBI-related technical standards,
- coordinates the distribution of and access to technical documents and standards,
- helps promulgate new technologies to the IVS community.

The Technology Coordinator works closely with the astronomical community, both to maintain technical compatibility between the geodetic and astronomical communities and to take advantage of technology development activities in the astronomical community.

## **4. Directing Board**

### **4.1. Roles and Responsibilities**

The Directing Board sets objectives, determines policies, adopts standards, and sets the scientific and operational goals for IVS. The Directing Board exercises general oversight of the activities of IVS including modifications to the organization that are deemed appropriate and necessary to maintain efficiency and reliability. The Directing Board may determine appropriate actions to ensure the quality of the IVS products.

The Directing Board will receive and review proposals for non-IVS research programs that request IVS resources.

### **4.2. Membership**

The Directing Board consists of representatives of the IVS components, members at-large, appointed members, and ex officio members. The members are:

Representatives of IVS Components (see below):

- Correlators and Operation Centers representative (1)
- Analysis and Data Centers representatives (2)

- Networks representatives (2)
- Technology Development Centers representative (1)

Elected by the Directing Board upon recommendation from the Coordinating Center (see below):

- Members at large (3)

Selected by Directing Board upon review of proposals from IVS Member Organizations:

- Coordinating Center Director
- Network Coordinator
- Analysis Coordinator
- Technology Coordinator

Appointed members:

- IAU representative
- IAG representative
- IERS representative

Through a reciprocity agreement between IVS and IERS, the IVS serves as the VLBI Technique Center for IERS, and as such its designated representative(s) serve on the IERS Directing Board. In turn, the IERS Directing Board designates a representative to the IVS Directing Board. This arrangement is to assure full cooperation between the two services.

Total number: 16

The members appointed by IAU, IAG, and IERS are not subject to institutional restrictions.

The six members who are the representatives of the IVS components are elected by the IVS Associate Members. All elected members serve staggered four-year terms once renewable.

At-large members are intended to ensure representation on the Directing Board of each of the components of IVS and to balance representation from as many countries and institutions and IVS interests as possible. At-large members serve two-year terms once renewable.

A Directing Board member who departs before the end of his/her term is replaced by a person selected by the Directing Board. The new member will serve until the next official elections. The position will then be filled for a full term.

An individual can only serve two consecutive full terms on the Board in any of the representative and at-large positions. Partial terms are not counted to this limit. After serving two consecutive full terms, an individual becomes eligible again for a position on the Board following a two-year absence.

The three Coordinators are selected by the Directing Board on the basis of proposals from IVS Member Organizations. On a two-thirds vote the Directing Board may call for new proposals for any Coordinator when it determines that a new Coordinator is required. Coordinators are encouraged to give at least six months notice before resigning.

### **4.3. Elections**

Election of Board members from the IVS components shall be conducted by a committee of three Directing Board members, the chair of which is appointed by the chair of the Directing Board. The committee solicits nominations for each representative from the relevant IVS components. For each position, the candidate who receives the largest number of votes from the Associate Members will be elected. In case of a tie the Directing Board will make the decision.

### **4.4. Chair**

The chair is one of the Directing Board members and is elected by the Board for a term of four years with the possibility of reelection for one additional term. The chair is the official representative of IVS to external organizations.

### **4.5. Decisions**

Most decisions by the Directing Board are made by consensus or by simple majority vote of the members present. In case of a tie, the chair decides how to proceed. If a two-thirds quorum is not present, the vote shall be held later by electronic mail. A two-thirds vote of all Board members is required to modify the Terms of Reference, to change the chair, or to replace any of the members before their normal term expires.

### **4.6. Meetings**

The Directing Board meets at least annually, or more frequently if meetings are called by the chair or at the request of at least three Board members. The Board will conduct periodic reviews of the IVS organization and its mandate, functions, and components.

## **5. Definitions**

### **5.1. Member Organizations**

Organizations that support one or more IVS components are IVS Member Organizations. Individuals associated with IVS Member Organizations may become IVS Associate Members.

### **5.2. Affiliated Organizations**

Organizations that cooperate with IVS on issues of common interest, but do not support an IVS component, are IVS Affiliated Organizations. Affiliated Organizations express an interest in establishing and maintaining a strong working association with IVS to mutual benefit. Individuals affiliated with IVS Affiliated Organizations may become IVS Corresponding Members.

### **5.3. Associate Members**

Individuals associated with organizations that support an IVS component may become IVS Associate Members. Associate Members take part in the election of the incoming members of the Directing Board representing the IVS components.

#### 5.4. Corresponding Members

IVS Corresponding Members are individuals who express interest in receiving IVS publications, wish to participate in workshops or scientific meetings organized by IVS, or generally are interested in IVS activities. Ex officio Corresponding Members are the following:

- IAG Secretary General
- Chair of GGOS
- President of IAG Commission 1 – Reference Frames
- President of IAG Commission 3 - Earth Rotation and Geodynamics
- President of IAU Division I – Fundamental Astronomy
- President of IAU Commission 8 – Astrometry
- President of IAU Commission 19 – Rotation of the Earth
- President of IAU Commission 31 – Time
- President of IAU Commission 40 – Radio Astronomy
- President of URSI Commission 52 – Relativity in Fundamental Astronomy
- President of URSI Commission J – Radio Astronomy

Individuals are accepted as IVS Corresponding Members upon request to the Coordinating Center.

*Last modified: 23 September 2011*



## IVS Member Organizations

(alphabetized by country)

Organization	Country
Commonwealth Scientific and Industrial Research Organisation (CSIRO)	Australia
Geoscience Australia	Australia
University of Tasmania	Australia
Vienna University of Technology	Austria
Centro de Rádio Astronomia e Aplicações Espaciais	Brazil
Dominion Radio Astrophysical Observatory	Canada
Geodetic Survey Division, Natural Resources Canada	Canada
Instituto Geográfico Militar	Chile
Universidad de Concepción	Chile
Chinese Academy of Sciences	China
Laboratoire d'Astrophysique de Bordeaux	France
Observatoire de Paris	France
Bundesamt für Kartographie und Geodäsie	Germany
Deutsches Geodätisches Forschungsinstitut	Germany
Forschungseinrichtung Satellitengeodäsie, TU Munich	Germany
Institut für Geodäsie und Geoinformation der Universität Bonn	Germany
Max-Planck-Institut für Radioastronomie	Germany
Agenzia Spaziale Italiana	Italy
Istituto di Radioastronomia INAF	Italy
Politecnico di Milano DIAR	Italy
Geospatial Information Authority of Japan	Japan
National Astronomical Observatory of Japan	Japan
National Institute of Information and Communications Technology	Japan
National Institute of Polar Research	Japan
Auckland University of Technology	New Zealand
Norwegian Defence Research Establishment	Norway
Norwegian Mapping Authority	Norway
Astronomical Institute of St.-Petersburg University	Russia
Institute of Applied Astronomy	Russia
Pulkovo Observatory	Russia
Sternberg State Astronomical Institute, Lomonosov Moscow State University	Russia
Hartebeesthoek Radio Astronomy Observatory	South Africa
Korea Astronomy and Space Science Institute	South Korea
Instituto Geográfico Nacional	Spain
Chalmers University of Technology	Sweden
Karadeniz Technical University	Turkey
Laboratory of Radioastronomy of Crimean Astrophysical Observatory	Ukraine

Members

---

Organization	Country
Main Astronomical Observatory, National Academy of Sciences, Kiev	Ukraine
Jet Propulsion Laboratory	USA
NASA Goddard Space Flight Center	USA
U. S. Naval Observatory	USA

---

## IVS Affiliated Organizations

Organization	Country
Australian National University	Australia
University of New Brunswick	Canada
FÖMI Satellite Geodetic Observatory	Hungary
Joint Institute for VLBI in Europe (JIVE)	Netherlands
Westerbork Observatory	Netherlands
National Radio Astronomy Observatory	USA

## IVS Associate Members

Name	Institution	Country	E-mail
Alef, Walter	Max-Planck-Institut für Radioastronomie	Germany	walef@mpifr-bonn.mpg.de
Amagai, Jun	National Institute of Information and Communications Technology	Japan	amagai@nict.go.jp
Andersen, Per Helge	Norwegian Defence Research Establishment	Norway	per-helge.andersen@ffi.no
Andreeva, Tatiana	Institute of Applied Astronomy	Russia	ats@urania.rtf32s.nw.ru
Artz, Thomas	Institut für Geodäsie und Geoinformation der Universität Bonn	Germany	thomas.artz@uni-bonn.de
Barache, Christophe	Observatoire de Paris	France	Christophe.Barache@obspm.fr
Baudry, Alain	Laboratoire d'Astrophysique de Bordeaux	France	baudry@obs.u-bordeaux1.fr
Bauernfeind, Erhard	Geodetic Observatory	Germany	bauernfeind@fs.wetzell.de
Baver, Karen	NVI, Inc.	USA	karen.d.baver@nasa.gov
Beaudoin, Christopher	MIT Haystack Observatory	USA	cbeaudoin@haystack.mit.edu
Beck, Norman	Natural Resources Canada	Canada	beck@nrca.gc.ca
Behrend, Dirk	NVI, Inc.	USA	Dirk.Behrend@nasa.gov
Bellanger, Antoine	Laboratoire d'Astrophysique de Bordeaux	France	bellanger@obs.u-bordeaux1.fr
Berdnikov, Anton	Institute of Applied Astronomy	Russia	
Bergman, Per	Onsala Space Observatory	Sweden	bergman@oso.chalmers.se
Bernhart, Simone	Institut für Geodäsie und Geoinformation der Universität Bonn	Germany	simone@mpifr-bonn.mpg.de
Bertarini, Alessandra	Institut für Geodäsie und Geoinformation der Universität Bonn	Germany	abertari@mpifr-bonn.mpg.de
Bianco, Giuseppe	Agenzia Spaziale Italiana	Italy	bianco@asi.it
Bielmaier, Ewald	Geodetic Observatory	Germany	bielmaier@fs.wetzell.de
Boboltz, David	U. S. Naval Observatory	USA	dboboltz@usno.navy.mil
Böhm, Johannes	Institute of Geodesy and Geophysics	Austria	johannes.boehm@tuwien.ac.at
Böhm, Sigrid	Institute of Geodesy and Geophysics	Austria	sigrid.boehm@tuwien.ac.at

Name	Institution	Country	E-mail
Boer, Armin	BKG/Project TIGO	Chile	armin.boer@bkg.bund.de
Bolotin, Sergei	NVI, Inc.	USA	sergei.bolotin@nasa.gov
Bougeard, Mireille	Observatoire de Paris	France	mireille.bougeard@obspm.fr
Bourda, Geraldine	Laboratoire d'Astrophysique de Bordeaux	France	bourda@obs.u-bordeaux1.fr
Buttaccio, Salvo	Istituto di Radioastronomia INAF	Italy	s.buttaccio@ira.inaf.it
Cappallo, Roger	MIT Haystack Observatory	USA	rcappallo@haystack.mit.edu
Carlson, Brent	Dominion Radio Astrophysical Observatory	Canada	bcarlson@drao.nrc.ca
Carter, Merri Sue	U. S. Naval Observatory, Flagstaff Station	USA	msc@nofs.navy.mil
Charlot, Patrick	Laboratoire d'Astrophysique de Bordeaux	France	charlot@obs.u-bordeaux1.fr
Cho, Junggho	Korea Astronomy & Space Science Institute	Korea	jojh@kasi.re.kr
Collioud, Arnaud	Laboratoire d'Astrophysique de Bordeaux	France	collioud@obs.u-bordeaux1.fr
Colomer, Francisco	Instituto Geográfico Nacional	Spain	f.colomer@oan.es
Colucci, Giuseppe	Telespazio SpA	Italy	giuseppe.colucci@telespazio.com
Combrinck, Ludwig	Hartebeesthoek Radio Astronomy Observatory	South Africa	ludwig@bootes.hartrao.ac.za
Conway, John	Onsala Space Observatory	Sweden	jconway@chalmers.se
Corey, Brian	MIT Haystack Observatory	USA	bcorey@haystack.mit.edu
Curtis, Ronald	ITT Information Systems	USA	ronald.curtis@exelisinc.com
Dassing, Reiner	Bundesamt für Kartographie und Geodäsie	Germany	reiner.dassing@bkg.bund.de
Del Rosso, Domenico	Telespazio SpA	Italy	domenico.delrosso@telespazio.it
de-Vicente, Pablo	Instituto Geográfico Nacional	Spain	p.devicente@oan.es
Diakov, Alexey	Institute of Applied Astronomy	Russia	ipazel@mail.svkchr.ru
Dickey, John	University of Tasmania	Australia	John.Dickey@utas.edu.au
Diegel, Irv	Honeywell TSI	USA	irv.diegel@honeywell-tsi.com
Doi, Koichiro	National Institute of Polar Research	Japan	doi@nipr.ac.jp
Dong, Yousuo	Urumqi Astronomical Observatory	China	dongys@ms.xjb.ac.cn
Drewes, Hermann	Deutsches Geodätisches Forschungsinstitut	Germany	drewes@dgfi.badw.de
Dube, Maurice	SSAI	USA	maurice.p.dube@nasa.gov

Name	Institution	Country	E-mail
Elgered, Gunnar	Onsala Space Observatory	Sweden	kge@chalmers.se
Engelhardt, Gerald	Bundesamt für Kartographie und Geodäsie	Germany	gerald.engelhardt@bkg.bund.de
Engen, Bjorn	Norwegian Mapping Authority	Norway	bjorn.engen@statkart.no
Evangelista, Mark	Honeywell TSI	USA	mark.evangelista@honeywell-tsi.com
Fan, Qingyuan	Shanghai Astronomical Observatory	China	qyfan@center.shao.ac.cn
Fedotov, Leonid	Institute of Applied Astronomy	Russia	flv@ipa.nw.ru
Fey, Alan	U. S. Naval Observatory	USA	afey@usno.navy.mil
Fukuzaki, Yoshihiro	Geospatial Information Authority of Japan	Japan	fukuzaki@gsi.go.jp
Gambis, Daniel	Observatoire de Paris	France	daniel.gambis@obspm.fr
García-Espada, Susana	Instituto Geográfico Nacional	Spain	s.gespada@oan.es
Gaume, Ralph	U. S. Naval Observatory	USA	rgaume@usno.navy.mil
Gipson, John	NVI, Inc.	USA	john.m.gipson@nasa.gov
Gomez, Frank	Raytheon	USA	frank.g.gomez@nasa.gov
Gómez-González, Jesús	Instituto Geográfico Nacional	Spain	gomez@oan.es
Gordon, David	NVI, Inc.	USA	david.gordon-1@nasa.gov
Govind, Ramesh	Geoscience Australia	Australia	ramesh.govind@ga.gov.au
Gubanov, Vadim	Institute of Applied Astronomy	Russia	gubanov@quasar.ipa.nw.ru
Gulyaev, Sergei	Auckland University of Technology	New Zealand	sergei.gulyaev@aut.ac.nz
Haas, Rüdiger	Onsala Space Observatory	Sweden	rudiger.haas@chalmers.se
Hall, David	U. S. Naval Observatory	USA	dhall@usno.navy.mil
Hammargren, Roger	Onsala Space Observatory	Sweden	rogham@chalmers.se
Hanssen, Rune	Norwegian Mapping Authority	Norway	rune.hanssen@statkart.no
Hase, Hayo	BKG/Project TIGO	Chile	hayo.hase@bkg.bund.de
Heinkelmann, Robert	Deutsches Geodätisches Forschungsinstitut	Germany	heinkelmann@dgfi.badw.de
Helldner, Leif	Onsala Space Observatory	Sweden	helldner@chalmers.se
Herrera, Cristian	TIGO/Universidad de Concepción	Chile	cristian.herrera@tigo.cl
Himwich, Ed	NVI, Inc.	USA	Ed.Himwich@nasa.gov
Hirabaru, Masaki	National Institute of Information and Communications Technology	Japan	masaki@nict.go.jp
Hobiger, Thomas	National Institute of Information and Communications Technology	Japan	hobiger@nict.go.jp

Name	Institution	Country	E-mail
Hong, Xiaoyu	Shanghai Astronomical Observatory	China	xhong@center.shao.ac.cn
Honma, Mareki	National Astronomical Observatory of Japan	Japan	honmamr@cc.nao.ac.jp
Huang, Xinyong	Shanghai Astronomical Observatory	China	xhuang@center.shao.ac.cn
Hugentobler, Urs	Geodetic Observatory	Germany	urs.hugentobler@bv.tu-muenchen.de
Ichikawa, Ryuichi	National Institute of Information and Communications Technology	Japan	richi@nict.go.jp
Ihde, Johannes	Bundesamt für Kartographie und Geodäsie	Germany	johannes.ihde@bkg.bund.de
Ilijin, Gennadiy	Institute of Applied Astronomy	Russia	
Ipatov, Alexander	Institute of Applied Astronomy	Russia	ipatov@ipa.rssi.ru
Ipatova, Irina	Institute of Applied Astronomy	Russia	ipatova@isida.ipa.rssi.ru
Ishihara, Misao	Geospatial Information Authority of Japan	Japan	vlbi@gsi.go.jp
Ishii, Atsutoshi	National Institute of Information and Communications Technology	Japan	ishii@nict.go.jp
Ivanov, D.V.	Institute of Applied Astronomy	Russia	
Jacobs, Chris	Jet Propulsion Laboratory	USA	chris.jacobs@jpl.nasa.gov
Jara, Cristobal	TIGO/Universidad de Concepción	Chile	cristobal.jara@tigo.cl
Jike, Takaaki	National Astronomical Observatory of Japan	Japan	jike@miz.nao.ac.jp
Johansson, Jan	Onsala Space Observatory	Sweden	jmj@chalmers.se
Johansson, Karl-Åke	Onsala Space Observatory	Sweden	karlake@chalmers.se
Johnson, Heidi	MIT Haystack Observatory	USA	hjohnson@haystack.mit.edu
Johnston, Kenneth	U. S. Naval Observatory	USA	kjj@astro.usno.navy.mil
Karasawa, Masao	Geospatial Information Authority of Japan	Japan	vlbi@gsi.go.jp
Kaufmann, Pierre	Centro de Rádio Astronomia e Aplicações Espaciais	Brazil	kaufmann@usp.br
Kawabata, Ryoji	Geospatial Information Authority of Japan	Japan	r-kawabata@gsi.go.jp
Kawaguchi, Noriyuki	National Astronomical Observatory of Japan	Japan	kawagu.nori@nao.ac.jp
Kawai, Eiji	National Institute of Information and Communications Technology	Japan	kawa@nict.go.jp
Kaydanovsky, Michael	Institute of Applied Astronomy	Russia	kmn@isida.ipa.rssi.ru

Name	Institution	Country	E-mail
Kayıkçı, Emine Tanır	Karadeniz Technical University	Turkey	etanir@ktu.edu.tr
Kharinov, Mikhail	Institute of Applied Astronomy	Russia	kharinov@ipa.rssi.ru
Kimura, Moritaka	National Institute of Information and Communications Technology	Japan	mkimura@nict.go.jp
Kingham, Kerry	U. S. Naval Observatory	USA	kak@usno.navy.mil
Kobayashi, Hideyuki	National Astronomical Observatory of Japan	Japan	hideyuki.kobayashi@nao.ac.jp
Kokado, Kensuke	Geospatial Information Authority of Japan	Japan	vlbi@gsi.go.jp
Kondo, Tetsuro	National Institute of Information and Communications Technology	Japan	kondo@nict.go.jp
Korkin, Edward	Institute of Applied Astronomy	Russia	korkin@isida.ipa.rssi.ru
Koyama, Yasuhiro	National Institute of Information and Communications Technology	Japan	koyama@nict.go.jp
Kronsnabl, Gerhard	Bundesamt für Kartographie und Geodäsie	Germany	gerhard.kronsnabl@bkg.bund.de
Kuboki, Hiromitsu	National Institute of Information and Communications Technology	Japan	kuboki@nict.go.jp
Kudryashova, Maria	Astronomical Institute of St.-Petersburg	Russia	kudryashova@mercury.astro.spbu.ru
Kurdubov, Sergey	Institute of Applied Astronomy	Russia	ksl@quasar.ipa.nw.ru
Kurihara, Shinobu	Geospatial Information Authority of Japan	Japan	skuri@gsi.go.jp
Kuroda, Jiro	Geospatial Information Authority of Japan	Japan	vlbi@gsi.go.jp
Labelle, Ruth	SSAI	USA	ruth.e.labelle@nasa.gov
Lambert, Sébastien	Observatoire de Paris	France	sebastien.lambert@obspm.fr
Langkaas, Line	Norwegian Mapping Authority	Norway	Line.Langkaas@statkart.no
Lanotte, Roberto	Telespazio SpA	Italy	lanotte@asi.it
Lauber, Pierre	Geodetic Observatory	Germany	lauber@fs.wetzell.de
Lavrov, Alexey	Institute of Applied Astronomy	Russia	
Le Bail, Karine	NVI, Inc.	USA	karine.lebail@nasa.gov
Li, Bing	Shanghai Astronomical Observatory	China	bing@center.shao.ac.cn
Li, Huihua	Shanghai Astronomical Observatory	China	hhl@center.shao.ac.cn
Li, Jinling	Shanghai Astronomical Observatory	China	jll@center.shao.ac.cn
Liang, Shiguang	Shanghai Astronomical Observatory	China	sgliang@center.shao.ac.cn



Name	Institution	Country	E-mail
Lindqvist, Michael	Onsala Space Observatory	Sweden	Michael.Lindqvist@chalmers.se
Liu, Xiang	Urumqi Astronomical Observatory	China	liux@ms.xjb.ac.cn
Long, Jim	NASA Goddard Space Flight Center	USA	jim.l.long@nasa.gov
Lonsdale, Colin	MIT Haystack Observatory	USA	clonsdale@haystack.mit.edu
Lovell, Jim	University of Tasmania	Australia	Jim.Lovell@utas.edu.au
Lowe, Stephen	Jet Propulsion Laboratory	USA	steve.lowe@jpl.nasa.gov
Lucena, Antonio	Centro de Rádio Astronomia e Aplicações Espaciais	Brazil	macilio@roen.inpe.br
Luzum, Brian	U. S. Naval Observatory	USA	bjl@maia.usno.navy.mil
Ma, Chopo	NASA Goddard Space Flight Center	USA	chopo.ma-1@nasa.gov
Maccaferri, Giuseppe	Istituto di Radioastronomia INAF	Italy	g.maccaferri@ira.inaf.it
Machida, Morito	Geospatial Information Authority of Japan	Japan	machida@gsi.go.jp
MacMillan, Dan	NVI, Inc.	USA	daniel.s.macmillan@nasa.gov
Malkin, Zinovy	Pulkovo Observatory	Russia	malkin@gao.spb.ru
Manabe, Seiji	National Astronomical Observatory of Japan	Japan	manabe@miz.nao.ac.jp
Mantovani, Franco	Istituto di Radioastronomia INAF	Italy	f.mantovani@ira.inaf.it
Mardyshkin, Vyacheslav	Institute of Applied Astronomy	Russia	vvm@isida.ipa.rssi.ru
Marshalov, Dmitry	Institute of Applied Astronomy	Russia	
Mathiassen, Geir	Norwegian Mapping Authority	Norway	matgei@statkart.no
Matsuzaka, Shigeru	Geospatial Information Authority of Japan	Japan	shigeru@gsi.go.jp
McCarthy, Dennis	U. S. Naval Observatory	USA	dmc@maia.usno.navy.mil
Melnikov, Alexey	Institute of Applied Astronomy	Russia	melnikov@quasar.ipa.nw.ru
Michailov, Andrey	Institute of Applied Astronomy	Russia	agm@isida.ipa.rssi.ru
Miller, Natalia	Pulkovo Observatory	Russia	natmiller@list.ru
Mitchell, Donald	Honeywell TSI	USA	kokee@pele.kpgo.hawaii.edu
Müskens, Arno	Institut für Geodäsie und Geoinformation der Universität Bonn	Germany	mueskens@mpifr-bonn.mpg.de

Name	Institution	Country	E-mail
Mukai, Yasuko	Geospatial Information Authority of Japan	Japan	mukai@gsi.go.jp
Nakajima, Junichi	National Institute of Information and Communications Technology	Japan	nakaji@nict.go.jp
Nanni, Mauro	Istituto di Radioastronomia INAF	Italy	m.nanni@ira.inaf.it
Natusch, Tim	Auckland University of Technology	New Zealand	tim.natusch@aut.ac.nz
Negusini, Monia	Istituto di Radioastronomia INAF	Italy	m.negusini@ira.inaf.it
Neidhardt, Alexander	Geodetic Observatory	Germany	neidhardt@fs.wetzell.de
Nicolson, George	Hartebeesthoek Radio Astronomy Observatory	South Africa	george@bootes.hartrao.ac.za
Niell, Arthur	MIT Haystack Observatory	USA	aniell@haystack.mit.edu
Nielsen, Carl-Petter	Norwegian Mapping Authority	Norway	carl-petter.nielsen@statkart.no
Nikitin, Pavel	Crimean Astrophysical Observatory	Ukraine	nikitin@crao.crimea.ua
Nilsson, Tobias	Institute of Geodesy and Geophysics	Austria	tobias.nilsson@tuwien.ac.at
Noll, Carey	NASA Goddard Space Flight Center	USA	Carey.Noll@nasa.gov
Nothnagel, Axel	Institut für Geodäsie und Geoinformation der Universität Bonn	Germany	nothnagel@uni-bonn.de
Nozawa, Kentarou	Geospatial Information Authority of Japan	Japan	nozawa@gsi.go.jp
Ogaja, Clement	Geoscience Australia	Australia	Clement.Ogaja@ga.gov.au
Olofsson, Hans	Onsala Space Observatory	Sweden	hans.olofsson@chalmers.se
Oñate, Eric	TIGO/Universidad del Bío Bío	Chile	eric.onate@tigo.cl
Orfei, Sandro	Istituto di Radioastronomia INAF	Italy	a.orfei@ira.inaf.it
Petrachenko, William	Natural Resources Canada	Canada	Bill.Petrachenko@nrc-cnrc.gc.ca
Pettersson, Lars	Onsala Space Observatory	Sweden	d8lars@chalmers.se
Plank, Lucia	Institute of Geodesy and Geophysics	Austria	lucia.plank@tuwien.ac.at
Plötz, Christian	Bundesamt für Kartographie und Geodäsie	Germany	christian.ploetz@bkg.bund.de
Poirier, Michael	MIT Haystack Observatory	USA	mpoirier@haystack.mit.edu
Qian, Zhihan	Shanghai Astronomical Observatory	China	qzh@center.shao.ac.cn
Quick, Jonathan	Hartebeesthoek Radio Astronomy Observatory	South Africa	jon@bootes.hartrao.ac.za

Name	Institution	Country	E-mail
Rahimov, Ismail	Institute of Applied Astronomy	Russia	rahimov@urania.rtf32s.nw.ru
Redmond, Jay	Honeywell TSI	USA	jay.redmond@honeywell-tsi.com
Reid, Brett	University of Tasmania	Australia	brett.reid@utas.edu.au
Rekkedal, Svein	Norwegian Mapping Authority	Norway	svein.rekkedal@statkart.no
Richter, Bernd	Bundesamt für Kartographie und Geodäsie	Germany	bernd.richter@bkg.bund.de
Rioja, Maria	Instituto Geográfico Nacional	Spain	mj.rioja@oan.es
Romero-Wolf, Andres	Jet Propulsion Laboratory	USA	andrew.romero-wolf@jpl.nasa.gov
Ruszczyk, Chester	MIT Haystack Observatory	USA	chester@haystack.mit.edu
Salnikov, Alexander	Institute of Applied Astronomy	Russia	salnikov@isida.ipa.rssi.ru
Sarti, Pierguido	Istituto di Radioastronomia INAF	Italy	p.sarti@ira.inaf.it
Schatz, Raimund	Geodetic Observatory	Germany	schatz@fs.wetzell.de
Scherneck, Hans-Georg	Onsala Space Observatory	Sweden	hgs@chalmers.se
Schuh, Harald	Institute of Geodesy and Geophysics	Austria	harald.schuh@tuwien.ac.at
Schwarz, Walter	Bundesamt für Kartographie und Geodäsie	Germany	walter.schwarz@bkg.bund.de
Schwegmann, Wolfgang	Bundesamt für Kartographie und Geodäsie	Germany	wolfgang.schwegmann@bkg.bund.de
Sciarretta, Cecilia	Telespazio SpA	Italy	cecilia@asi.it
Searle, Anthony	Natural Resources Canada	Canada	asearle@NRCan.gc.ca
Sekido, Mamoru	National Institute of Information and Communications Technology	Japan	sekido@nict.go.jp
Seitz, Manuela	Deutsches Geodätisches Forschungsinstitut	Germany	seitz@dgfi.badw.de
Shao, Minghui	Urumqi Astronomical Observatory	China	nanshan@ms.xjb.ac.cn
Shibuya, Kazuo	National Institute of Polar Research	Japan	shibuya@nipr.ac.jp
Shishikin, Alexandr	Institute of Applied Astronomy	Russia	
Shu, Fengchun	Shanghai Astronomical Observatory	China	sfc@center.shao.ac.cn
Skurikhina, Elena	Institute of Applied Astronomy	Russia	sea@quasar.ipa.nw.ru
Smolentsev, Sergey	Institute of Applied Astronomy	Russia	smolen@isida.ipa.rssi.ru
Smythe, Dan	MIT Haystack Observatory	USA	dsmythe@haystack.mit.edu

Name	Institution	Country	E-mail
Sobarzo, Sergio	TIGO/Universidad de Concepción	Chile	sergio.sobarzo@tigo.cl
Sousa, Don	MIT Haystack Observatory	USA	dsousa@haystack.mit.edu
Sovers, Ojars	Remote Sensing Analysis Inc.	USA	ojars@oregonfast.net
Spicakova, Hana	Institute of Geodesy and Geophysics	Austria	hana@mars.hg.tuwien.ac.at
Stanghellini, Carlo	Istituto di Radioastronomia INAF	Italy	c.stanghellini@ira.inaf.it
Steppe, Alan	Jet Propulsion Laboratory	USA	as@logos.jpl.nasa.gov
Surkis, Igor	Institute of Applied Astronomy	Russia	surkis@isida.ipa.rssi.ru
Takashima, Kazuhiro	Geospatial Information Authority of Japan	Japan	takasima@gsi.go.jp
Tagiguchi, Hiroshi	National Institute of Information and Communications Technology	Japan	htaki@nict.go.jp
Tamura, Yoshiaki	National Astronomical Observatory of Japan	Japan	tamura@miz.nao.ac.jp
Tanimoto, Daisuke	Geospatial Information Authority of Japan	Japan	vlbi@gsi.go.jp
Tao, An	Shanghai Astronomical Observatory	China	antao@center.shao.ac.cn
Tateyama, Claudio	Centro de Rádio Astronomia e Aplicações Espaciais	Brazil	tateyama@craam.mackenzie.br
Teke, Kamil	Hacettepe University	Turkey	kteke@hacettepe.edu.tr
Thomas, Cynthia	NVI, Inc.	USA	cynthia.c.thomas@nasa.gov
Thorandt, Volkmar	Bundesamt für Kartographie und Geodäsie	Germany	volkmar.thorandt@bkg.bund.de
Thornton, Bruce	U. S. Naval Observatory	USA	blt@usno.navy.mil
Titov, Oleg	Geoscience Australia	Australia	Oleg.Titov@ga.gov.au
Titus, Mike	MIT Haystack Observatory	USA	mtitus@haystack.mit.edu
Todorova, Sonja	Institute of Geodesy and Geophysics	Austria	stodo@mars.hg.tuwien.ac.at
Tomasi, Paolo	Istituto di Radioastronomia INAF	Italy	tomasi@ira.inaf.it
Trigilio, Corrado	Istituto di Radioastronomia INAF	Italy	ctrigilio@oact.inaf.it
Tsutsumi, Masanori	National Institute of Information and Communications Technology	Japan	tsutsumi@nict.go.jp
Tuccari, Gino	Istituto di Radioastronomia INAF	Italy	g.tuccari@ira.inaf.it
Ullrich, Dieter	Bundesamt für Kartographie und Geodäsie	Germany	dieter.ullrich@bkg.bund.de
Venturi, Tiziana	Istituto di Radioastronomia INAF	Italy	t.venturi@ira.inaf.it

Name	Institution	Country	E-mail
Verdugo, Carlos	TIGO/Universidad de Concepción	Chile	carlos.verdugo@tigo.cl
Vespe, Francesco	Agenzia Spaziale Italiana	Italy	vespe@asi.it
Vityazev, Veniamin	Astronomical Institute of St.-Petersburg	Russia	vityazev@list.ru
Volvach, Alexandr	Crimean Astrophysical Observatory	Ukraine	volvach@crao.crimea.ua
Vytnov, Alexander	Institute of Applied Astronomy	Russia	vytnov@isida.ipa.rssi.ru
Wang, Guangli	Shanghai Astronomical Observatory	China	wgl@center.shao.ac.cn
Wang, Jinqing	Shanghai Astronomical Observatory	China	jqwang@center.shao.ac.cn
Wang, Lingling	Shanghai Astronomical Observatory	China	llwang@center.shao.ac.cn
Wang, Na	Urumqi Astronomical Observatory	China	Na.wang@ms.xjb.ac.cn
Wang, Weixia	Urumqi Astronomical Observatory	China	wangwx@ms.xjb.ac.cn
Wei, Wenren	Shanghai Astronomical Observatory	China	wwr@center.shao.ac.cn
Whitney, Alan	MIT Haystack Observatory	USA	awhitney@haystack.mit.edu
Wojdziak, Reiner	Bundesamt für Kartographie und Geodäsie	Germany	reiner.wojdziaak@bkg.bund.de
Yatskiv, Yaroslav	Main Astronomical Observatory	Ukraine	yatskiv@mao.kiev.ua
Ye, Shuhua	Shanghai Astronomical Observatory	China	ysh@center.shao.ac.cn
Yusup, Aili	Urumqi Astronomical Observatory	China	aliyu@ms.xjb.ac.cn
Zeitlhöfler, Reinhard	Geodetic Observatory	Germany	zeitlhoefler@fs.wettzell.de
Zhang, Ali	Urumqi Astronomical Observatory	China	zhangal@uao.ac.cn
Zhang, Jin	Urumqi Astronomical Observatory	China	zhangj@ms.xjb.ac.cn
Zhang, Xiuzhong	Shanghai Astronomical Observatory	China	xzhang@shao.ac.cn
Zhao, Rongbing	Shanghai Astronomical Observatory	China	zhaorb@center.shao.ac.cn
Zheng, Weimin	Shanghai Astronomical Observatory	China	zhwm@shao.ac.cn
Zhou, Ruixian	Shanghai Astronomical Observatory	China	zrx@center.shao.ac.cn

## IVS Permanent Components

(listed by types, within types alphabetical by component name)

### Network Stations

Component Name	Sponsoring Organization	Country
Radioastronomical Observatory Badary	Institute of Applied Astronomy RAS	Russia
Fortaleza, Radio Observatório Espacial do Nordeste (ROEN)	Centro de Rádio Astronomia e Aplicações Espaciais	Brazil
Goddard Geophysical and Astronomical Observatory	NASA Goddard Space Flight Center	USA
Hartebeesthoek Radio Astronomy Observatory	Foundation for Research and Development	South Africa
Hobart 12-m and 26-m, Katherine and Yarragadee	University of Tasmania	Australia
Kashima 34-m	National Institute of Information and Communications Technology (NICT)	Japan
Key Stone Project Kashima 11-m	National Institute of Information and Communications Technology (NICT)	Japan
Key Stone Project Koganei	National Institute of Information and Communications Technology (NICT)	Japan
Kokee Park Geophysical Observatory	National Earth Orientation Service (NEOS)	USA
Matera	Agenzia Spaziale Italiana (ASI)	Italy
Medicina	Istituto di Radioastronomia	Italy
Mizusawa 10-m	National Astronomical Observatory of Japan (NAOJ)	Japan
Noto (Sicily)	Istituto di Radioastronomia	Italy
Ny-Ålesund Geodetic Observatory	Norwegian Mapping Authority	Norway
ERS/VLBI Station O'Higgins	Bundesamt für Kartographie und Geodäsie (BKG)	Germany
Onsala Space Observatory	Chalmers University of Technology	Sweden
Parkes Observatory	CSIRO Astronomy and Space Science	Australia
Seshan	Joint Laboratory for Radio Astronomy (JLRA), CAS and Shanghai Observatory, CAS	China
Simeiz	Laboratory of Radioastronomy of Crimean Astrophysical Observatory	Ukraine
Svetloe Radio Astronomy Observatory	Institute of Applied Astronomy RAS	Russia
JARE Syowa Station	National Institute of Polar Research	Japan

Transportable Integrated Geodetic Observatory (TIGO)	Universidad de Concepción (UdeC), Instituto Geográfico Militar (IGM), Bundesamt für Kartographie und Geodäsie (BKG)	Germany, Chile
Tsukuba VLBI Station	Geospatial Information Authority of Japan (GSI)	Japan
Nanshan VLBI Station	Chinese Academy of Sciences	China
Warkworth Observatory	Auckland University of Technology	New Zealand
Westford Antenna, Haystack Observatory	NASA Goddard Space Flight Center	USA
Geodätisches Observatorium Wettzell	Bundesamt für Kartographie und Geodäsie (BKG) and Forschungseinrichtung Satellitengeodäsie der Technischen Universität München (FESG)	Germany
Observatorio Astronómico Nacional - Yebes	Instituto Geográfico Nacional	Spain
Radioastronomical Observatory Zelenchukskaya	Institute of Applied Astronomy RAS	Russia

### Operation Centers

Component Name	Sponsoring Organization	Country
Institut für Geodäsie und Geoinformation (IGGB)	Universität Bonn	Germany
CORE Operation Center	NASA Goddard Space Flight Center	USA
NEOS Operation Center	National Earth Orientation Service (NEOS)	USA

### Correlators

Component Name	Sponsoring Organization	Country
Astro/Geo Correlator at MPI	Bundesamt für Kartographie und Geodäsie, Institut für Geodäsie und Geoinformation der Universität Bonn, Max-Planck-Institut für Radioastronomie	Germany
MIT Haystack Correlator	NASA Goddard Space Flight Center	USA
Institute of Applied Astronomy Correlator	Institute of Applied Astronomy RAS	Russia
National Institute of Information and Communications Technology (NICT)	National Institute of Information and Communications Technology (NICT)	Japan
Tsukuba VLBI Center	Geospatial Information Authority of Japan (GSI)	Japan
Washington Correlator	National Earth Orientation Service (NEOS)	USA

### Data Centers

Component Name	Sponsoring Organization	Country
BKG, Leipzig	Bundesamt für Kartographie und Geodäsie	Germany
Crustal Dynamics Data Information System (CDDIS)	NASA Goddard Space Flight Center	USA
GeoDAF	Agenzia Spaziale Italiana (ASI)	Italy
Italy INAF	Istituto di Radioastronomia INAF	Italy
National Institute of Information and Communications Technology	National Institute of Information and Communications Technology	Japan
Observatoire de Paris	Observatoire de Paris	France

### Analysis Centers

Component Name	Sponsoring Organization	Country
Astronomical Institute of St.-Petersburg University	Astronomical Institute of St.-Petersburg University	Russia
Geoscience Australia	Geoscience Australia	Australia
BKG/DGFI Combination Center	Bundesamt für Kartographie und Geodäsie and Deutsches Geodätisches Forschungsinstitut	Germany
Laboratoire d'Astrophysique de Bordeaux	Laboratoire d'Astrophysique de Bordeaux	France
Centro di Geodesia Spaziale (CGS)	Agenzia Spaziale Italiana	Italy
DGFI	Deutsches Geodätisches Forschungsinstitut	Germany
Forsvarets forskningsinstitutt (FFI)	Norwegian Defence Research Establishment	Norway
IGGB-BKG Analysis Center	Institut für Geodäsie und Geoinformation der Universität Bonn and Bundesamt für Kartographie und Geodäsie	Germany
Goddard Space Flight Center	NASA Goddard Space Flight Center	USA
Haystack Observatory	MIT Haystack Observatory and NASA Goddard Space Flight Center	USA
Institute of Applied Astronomy Analysis Center	Institute of Applied Astronomy RAS	Russia
Institute of Geodesy and Geophysics (IGG)	Institute of Geodesy and Geophysics (IGG) of Vienna University of Technology	Austria
Italy INAF	Istituto di Radioastronomia INAF	Italy
Jet Propulsion Laboratory	Jet Propulsion Laboratory	USA
Karadeniz Technical University (KTU)	Karadeniz Technical University	Turkey
Korea Astronomy and Space Science Institute	Korea Astronomy and Space Science Institute	South Korea



Main Astronomical Observatory	Main Astronomical Observatory, National Academy of Sciences, Kiev	Ukraine
National Astronomical Observatory of Japan	National Astronomical Observatory of Japan	Japan
National Institute of Information and Communications Technology	National Institute of Information and Communications Technology	Japan
Norwegian Mapping Authority (NMA)	Norwegian Mapping Authority (NMA)	Norway
Observatoire de Paris	Observatoire de Paris	France
Onsala Space Observatory	Chalmers University of Technology	Sweden
Politecnico di Milano DIAR	Politecnico di Milano DIAR (PMD)	Italy
Pulkovo Observatory	Pulkovo Observatory	Russia
Sternberg State Astronomical Institute	Lomonosov Moscow State University	Russia
Shanghai Observatory	Shanghai Observatory, Chinese Academy of Sciences	China
Tsukuba VLBI Analysis Center	Geospatial Information Authority of Japan (GSI)	Japan
U. S. Naval Observatory Analysis Center	U. S. Naval Observatory	USA
U. S. Naval Observatory Analysis Center for Source Structure	U. S. Naval Observatory	USA

### Technology Development Centers

Component Name	Sponsoring Organization	Country
Canadian VLBI Technology Development Center	NRCan, DRAO	Canada
Forsvarets forskningsinstitutt (FFI)	Norwegian Defence Research Establishment	Norway
Goddard Space Flight Center	NASA Goddard Space Flight Center	USA
Haystack Observatory	MIT Haystack Observatory and NASA Goddard Space Flight Center	USA
Institute of Applied Astronomy Technology Development Center	Institute of Applied Astronomy RAS	Russia
National Institute of Information and Communications Technology	National Institute of Information and Communications Technology	Japan
Onsala Space Observatory	Chalmers University of Technology	Sweden

## Addresses of Institutions of Authors Contributing to this Report

(listed alphabetically by country)

### CSIRO Astronomy and Space Science

PO Box 76  
Epping  
NSW 1710  
Australia  
<http://www.atnf.csiro.au>

### Geoscience Australia

PO Box 378  
Canberra ACT  
2601  
Australia  
<http://ga.gov.au>

### University of Tasmania

School of Mathematics and Physics  
University of Tasmania  
Private Bag 37  
Hobart 7001  
Australia  
<http://auscope.phys.utas.edu.au>

### Institute of Geodesy and Geophysics/University of Technology, Vienna

Gusshausstrasse 27-29  
1040 Vienna  
Austria  
<http://www.hg.tuwien.ac.at>

### CRAAM, Universidade Presbiteriana Mackenzie, São Paulo

CRAAM  
Instituto Presbiteriano Mackenzie  
Rua da Consolação 896  
01302-907 São Paulo  
SP  
Brazil  
<http://www.craam.mackenzie.br>

### Instituto Nacional de Pesquisas Espaciais

Estrada do Fio 6000  
Bairro Tupuiú  
1760-000 Eusébio  
CE  
Brazil  
<http://www.roen.inpe.br>

Geodetic Survey Division, Natural Resources Canada  
615 Booth St.  
Ottawa  
Ontario  
Canada K1A 0E9  
<http://www.geod.nrcan.gc.ca>

Bundesamt für Kartographie und Geodäsie - TIGO  
Casilla 4036  
Correo 3  
Concepción  
Chile  
<http://www.bkg.bund.de>

Universidad de Concepción - TIGO  
Concepción  
Chile  
<http://www.udec.cl>

Shanghai Astronomical Observatory, Chinese Academy of Sciences  
80 Nandan Road  
Shanghai 200030  
China  
<http://www.shao.ac.cn/eng/>

Xinjiang Astronomical Observatory, NAO-CAS  
40-5 South Beijing Road  
Urumqi  
Xinjiang Uygur Autonomous Region  
830011  
China  
<http://www.uao.ac.cn>

Laboratoire d'Astrophysique de Bordeaux  
2 rue de l'Observatoire  
BP 89  
33271 Floirac Cedex  
France  
<http://www.obs.u-bordeaux1.fr>

Observatoire de Paris, SYRTE, CNRS/UMR8630  
61 avenue de l'Observatoire  
75014 Paris  
France  
<http://www.obspm.fr>

Bundesamt für Kartographie und Geodäsie, BKG  
Richard-Strauss-Allee 11  
60598 Frankfurt am Main  
Germany  
<http://www.bkg.bund.de>

Deutsches Geodätisches Forschungsinstitut, DGFI

Alfons-Goppel-Strasse 11  
80539 München  
Germany  
<http://www.dgfi.badw.de>

Geodätisches Observatorium Wettzell

Bundesamt für Kartographie und Geodäsie (BKG) and  
Forschungseinrichtung Satellitengeodäsie (FESG)  
Sackenrieder Str. 25.  
D-93444 Bad Kötzing  
Germany  
<http://www.fs.wettzell.de>

Institut für Geodäsie und Geoinformation der Universität Bonn

Nussallee 17  
D-53115 Bonn  
Germany  
<http://vlbi.geod.uni-bonn.de>

Max-Planck-Institute for Radioastronomy

Auf dem Hügel 69  
53121 Bonn  
Germany  
<http://www.mpifr-bonn.mpg.de>

Agenzia Spaziale Italiana

Centro di Geodesia Spaziale (CGS)  
Contrada Terlecchia  
75100 Matera  
Italy  
<http://www.asi.it>

Istituto di Radioastronomia–Bologna

Via P. Gobetti 101  
40129 Bologna  
Italy  
<http://www.ira.inaf.it>

Istituto di Radioastronomia, Medicina

C.P. 14  
40060 Villafontana  
Bologna  
Italy  
<http://www.med.ira.inaf.it>

Istituto di Radioastronomia INAF, Stazione VLBI di Noto  
C.P. 161  
I-96017 Noto SR  
Italy  
<http://www.noto.ira.inaf.it>

Politecnico di Milano, DIIAR  
Politecnico di Milano University  
DIIAR  
Sezione Rilevamento  
Piazza Leonardo da Vinci 32  
I-20133 Milano  
Italy  
<http://www.diiar.polimi.it>

Geospatial Information Authority of Japan  
Code 305-0811  
Kitasato 1  
Tsukuba  
Ibaraki  
Japan  
<http://www.spacegeodesy.go.jp/vlbi/en>

Mizusawa VLBI Observatory, NAOJ  
2-12 Hoshigaoka-cho  
Mizusawa-kuk  
Oshu-shi  
Iwateken  
023-0861  
Japan  
<http://www.miz.nao.ac.jp>

National Institute of Information and Communications Technology  
893-1 Hirai  
Kashima  
Ibaraki 314-08501  
Japan  
<http://www2.nict.go.jp/w/w114/stmg/index.e.html>

National Institute of Polar Research  
10-3  
Midori-cho  
Tachikawa-shi  
Tokyo 190-8518  
Japan  
<http://www.nipr.ac.jp>

Institute for Radio Astronomy and Space Research, Auckland University of Technology  
Private Bag 92006  
Auckland 1142  
New Zealand  
<http://www.irasr.aut.ac.nz>

Forsvarets forskningsinstitutt (FFI) (Norwegian Defence Research Establishment)  
FFI/III  
Box 25  
2007 Kjeller  
Norway  
<http://www.ffi.no/>

Norwegian Mapping Authority (NMA)  
Kartverksveien 21  
3507 Hønefoss  
Norway  
<http://www.kartverket.no/>

Institute of Applied Astronomy of Russian Academy of Sciences (IAA)  
nab. Kutuzova 10  
St. Petersburg  
191187  
Russia  
<http://www.ipa.nw.ru>

Pulkovo Observatory  
Pulkovskoe Ch. 65  
St. Petersburg  
196140  
Russia  
<http://www.gao.spb.ru>

Sobolev Astronomical Institute of Saint Petersburg University  
Universitetskii pr. 28  
Starii Peterhof  
Saint Petersburg  
198504  
Russia  
<http://www.astro.spbu.ru>

Sternberg State Astronomical Institute (SAI) of Lomonosov Moscow State University  
Universitetskij prospekt 13  
Moscow  
119991  
Russia  
<http://www.sai.msu.ru>

HartRAO, NRF

PO Box 443

Krugersdorp

1740

South Africa

<http://www.hartrao.ac.za>

Korea Astronomy and Space Science Institute

305-348

South Korea

<http://www.kasi.re.kr>

Instituto Geográfico Nacional

Calle General Ibañez de Ibero 3

E-28003 Madrid

Spain

<http://www.ign.es/>

Observatório Astronómico Nacional

Calle Alfonso XII 3

E-28014 Madrid

Spain

<http://www.oan.es/>

Onsala Space Observatory (OSO)

SE-439 92

Onsala

Sweden

<http://www.oso.chalmers.se>

Hacettepe University, Department of Geomatics Engineering

Beytepe

06800

Ankara

Turkey

<http://geomatik.hacettepe.edu.tr>

Karadeniz Technical University, Department of Geomatics Engineering

Trabzon

61080

Turkey

<http://www.harita.ktu.edu.tr>

Main Astronomical Observatory, National Academy of Sciences of Ukraine

Main Astronomical Observatory

27 Akademika Zabolotnoho St.

Kiev

03680

Ukraine

<http://www.mao.kiev.ua>

Radio Astronomy Lab of Crimean Astrophysical Observatory  
RT-22  
Katsively  
Yalta Crimea 98688  
Ukraine  
<http://www.crao.crimea.ua>

Jet Propulsion Laboratory, California Institute of Technology  
Mail Stop 238-600  
4800 Oak Grove Dr.  
Pasadena, CA 91109  
USA  
<http://www.jpl.nasa.gov>

Kokee Park Geophysical Observatory  
Kokee State Park  
P.O. Box 538  
Waimea, Hawaii 96796  
USA  
[http://lupus.gsfc.nasa.gov/kokee\\_park.htm](http://lupus.gsfc.nasa.gov/kokee_park.htm)

MIT Haystack Observatory  
Off Route 40  
Westford, MA 01886  
USA  
<http://www.haystack.mit.edu/>

NASA Goddard Space Flight Center  
Code 698.2  
Greenbelt, MD 20771  
USA  
<http://www.nasa.gov>

U.S. Naval Observatory  
3450 Massachusetts Ave. NW  
Washington, DC 20392  
USA  
<http://www.usno.navy.mil>

U.S. Naval Observatory, Flagstaff Station  
10391 West Naval Observatory Rd.  
Flagstaff, AZ 86001  
USA  
<http://www.nofs.navy.mil>



---

## List of Acronyms

AAM	Atmosphere Angular Momentum
AARNet	Australia Academic and Research Network
AAS	American Astronomical Society
AC	(IVS) Analysis Center
ACF	AutoCorrelation Function
ACU	Antenna Control Unit
AD	Analog-to-Digital
ADB	Analog to Digital Board
ADC	Analog to Digital Converter
ADEV	Allan DEVIation
AEB	Agência Espacial Brasileira (Brazilian Space Agency) (Brazil)
AER	Atmospheric and Environmental Research, Inc. (USA)
AES	Advanced Engineering Services Co., Ltd (Japan)
AGILE	Astro-rivelatore Gamma ad Immagini LEggero satellite (Italy)
AGN	Active Galactic Nuclei
AGU	American Geophysical Union
AIPS	Astronomical Image Processing System
AIUB	Astronomical Institute, University of Bern (Switzerland)
ALMA	Atacama Large Millimeter Array
AMRFP	Access to Major Research Facilities Program
ANU	Australian National University (Australia)
AO	Astronomical Object
AOA	Allen Osborne Associates
AOC	Array Operation Center (Japan)
AOG	Auxilliary Output Generator
APEX	Atacama Pathfinder EXperiment (Chile)
API	Application Programming Interface
APPS	Advanced Precise Positioning System
APSG	Asia-Pacific Space Geodynamics program
APT	Asia Pacific Telescope
APTF	Asian Pacific Time and Frequency
ARC	Astrometric Radiointerferometric Correlator
ARIES	Astronomical Radio Interferometric Earth Surveying program
ARO	Algonquin Radio Observatory (Canada)
ASC	Astro Space Center (Russia)
ASD	Allan Standard Deviation
ASI	Agenzia Spaziale Italiana (Italy)
ASKAP	Australian Square Kilometre Array Pathfinder (Australia)
ATA	Advanced Technology Attachment
ATA	Allen Telescope Array (USA)
ATCA	Australia Telescope Compact Array (Australia)
ATM	Asynchronous Transfer Mode

ATNF	Australia Telescope National Facility (Australia)
AUSLIG	AUstralian Surveying and Land Information Group (now Geoscience Australia (GA)) (Australia)
AUT	Auckland University of Technology (New Zealand)
A-WVR	Advanced Water Vapor Radiometer
BAdW	Bayerische Akademie der Wissenschaften (Bavarian Academy of Sciences and Humanities) (Germany)
BBC	Base Band Converter
BdRAO	Badary Radio Astronomical Observatory (Russia)
BEK	Bayerische Kommission für die internationale Erdmessung (Germany)
BIPM	Bureau International de Poids et Mesures (France)
BKG	Bundesamt für Kartographie und Geodäsie (Germany)
BMC	Basic Module of Correlator
BOR1	Body Of Revolution type 1
BOSSNET	BOSon South NETwork
BPE	Bernese Processing Engine
BPF	Band Pass Filter
BVID	Bordeaux VLBI Image Database
BW	Band Width
BWG	Beam WaveGuide
CACS	Canadian Active Control System
CAGS	Council of Astronomical and Geophysical data analysis Services
CARAVAN	Compact Antenna of Radio Astronomy for VLBI Adapted Network (Japan)
CAS	Chinese Academy of Sciences (China)
CASPER	Center for Astronomy Signal Processing and Electronics Research (USA)
CAY	Centro Astronómico de Yebes (Spain)
CC	(IVS) Combination Center
CC	(IVS) Coordinating Center
CDDIS	Crustal Dynamics Data Information System (USA)
CDP	Crustal Dynamics Project
CDT	Centro de Desarrollo Tecnológico at Yebes Observatory (Spain)
CE	Conformité Européene
CE-1	Chang'E-1 (China)
CfA	Harvard-Smithsonian Center for Astrophysics (USA)
CGE	Centrum für Geodätische Erdsystemforschung (Germany)
CGLBI	Canadian Geodetic Long Baseline Interferometry
CGPS	Continuous GPS
CGS	Centro di Geodesia Spaziale (Italy)
CHAMP	Challenging Mini-Satellite Payload
CIB	Correlator Interface Board
CIP	Celestial Intermediate Pole
CLARA	Cooperación Latino Americana de Redes Avanzadas
CLIWA-NET	Cloud LIquid WATER NETwork
CMB	Core-Mantle Boundary

---

CMNOC	Crustal Monitoring Network Of the Chinese mainland geological environment (China)
CMONC	Crustal Movement Observation Network of China (China)
CMVA	Coordinated Millimeter VLBI Array
CNES	Centre National d'Etudes Spatiales (France)
CNIG	Centro Nacional de Información Geográfica (Spain)
CNR	Consiglio Nazionale delle Ricerche (Italy)
CNRS	Centre National de la Recherche Scientifique (France)
CNS	Communication, Navigation and Surveillance systems, Inc. (USA)
CODA	Correlator Output Data Analyzer
COL	Combination at the Observation Level
CONGO	COoperative Network for GIOVE Observation
CORE	Continuous Observations of the Rotation of the Earth
CORS	Continuously Operating Reference Stations
COTS	Commercial-Off-The-Shelf
CP	Circularly Polarized
CPO	Celestial Pole Offset
CPP	IERS Combination Pilot Project
CRAAE	Centro de Rádio Astronomia e Aplicações Espaciais (Brazil)
CRAAM	Centro de Rádio Astronomia e Astrofísica Mackenzie (Brazil)
CrAO	Crimean Astrophysical Observatory (Ukraine)
CRDS	Celestial Reference frame Deep South
CRESTech	Centre for Research in Earth and Space Technology (Canada)
CRF	Celestial Reference Frame
CRL	Communications Research Laboratory (now NICT) (Japan)
CRS	Celestial Reference System
CSA	Canadian Space Agency (Canada)
C-SART	Constrained Simultaneous Algebraic Reconstruction Technique
CSCU	Cryogenic System Control Unit
CSIR	Council for Scientific and Industrial Research (South Africa)
CSIRO	Commonwealth Scientific and Industrial Research Organisation (Australia)
CSRIFS	Combined Square Root Information Filter and Smoother
CSRS	Canadian Spatial Reference System
CSTnet	China Science and Technology Network (China)
CTVA	Canadian Transportable VLBI Antenna
CUTE	CRL and University Telescopes Experiment (Japan)
CVN	Chinese VLBI Network
CW	Continuous Wave
CWDM	Coarse Wavelength Division Multiplexer
CYLAR	CDT Yebes Laser Ranging
DAO	GSFC Data Assimilation Office (USA)
DAR	Data Acquisition Rack
DAS	Data Acquisition System
DASOS	DAS Operating System
DAT	Digital Audio Tape

DBBC	Digital Base Band Converter
DBE	Digital BackEnd
DDC	Digital DownConverter
DDOR	Delta Differenced One-way Range
DeltaDOR	Delta Differenced One-way Range
DFG	Deutsche Forschungsgemeinschaft (German Research Foundation) (Germany)
DFT	Discrete Fourier Transform
DGFI	Deutsches Geodätisches ForschungsInstitut (Germany)
DGK	Deutsche Geodätische Kommission (Germany)
dGPS	differential GPS
DHC	de Havilland Canada Company
DIAR	Dipartimento di Ingegneria Idraulica, Ambientale, Infrastrutture viarie, Rilevamento (Italy)
DIISR	Department of Innovation, Industry, Science and Research (Australia)
DIM	Data Input Module
DISTART	Dipartimento di Ingegneria delle Strutture, dei Trasporti, delle Acque, del Rilevamento del Territorio (Italy)
DLR	Deutsches Zentrum für Luft- und Raumfahrt (German Aerospace Center)
DNSC	Danish National Space Center (Denmark)
DOM	Data Output Module
DOMES	Directory Of MERIT Sites
DORIS	Doppler Orbitography and Radiopositioning Integrated by Satellite
DPFU	Degrees Per Flux Unit
DPN	Dual Pseudo-random Noise
DR	Dichroic Reflector
DRAGON	Dynamic Resource Allocation through GMPLS over Optical Networks
DRAO	Dominion Radio Astrophysical Observatory (Canada)
DSAMS	Direct Sampling Applied for Mixed Signals
DSCB	Data Stream Combining Board
DSCIG	Direcção de Serviços de Cartografia e Informação Geográfica (Portugal)
DSIF	Deep Space Instrumentation Facility
DSN	Deep Space Network
DSNA	Deep Space Network Array (USA)
DSP	Digital Signal Processor
DSS	Deep Space Station
DTU10	Danmarks Tekniske Universitet (Denmark)
D-VLBI	Differential VLBI
EAN	Eastern Asia VLBI Network
EAS	European Astronomical Society
ECMWF	European Centre for Medium-Range Weather Forecasts
EDM	Electronic Distance Measurement
EFTF	European Frequency and Time Forum
EGAE	Experiment Guided Adaptive Endpoint
EGS	European Geophysical Society
EGU	European Geosciences Union

---

EIA	Environmental Impact Assessment
ELSA	European Leadership in Space Astrometry
ENC GNSS	European Navigation Conference on Global Navigation Satellite Systems
ENSG	L'École Nationale des Sciences Géographiques
ENSO	El-Niño/Southern Oscillation
ENVISAT	ENVironmental SATellite
EOP	Earth Orientation Parameter
EOP-PC	Earth Orientation Parameter Product Center (France)
EOS	Earth Observing System
EOT	Empirical Ocean Tide
EOT8A	Empirical Ocean Tide 2008 model from multi-mission satellite Altimetry
ERP	Earth Rotation Parameter
ERS	European Remote Sensing Satellites
ESA	European Space Agency
ESO	European Southern Observatory
ETS-8	Engineering Test Satellite 8
ETSIT	Escuela Técnica Superior de Ingenieros de Telecomunicación
ETS-Lindgren	EMC Test Systems-Lindgren (USA)
ETS-VIII	Engineering Test Satellite 8
EU	European Union
EuCAP	European Conference on Antennas and Propagation
EUREF	EUropean REFerence Frame
EVGA	European VLBI for Geodesy and Astrometry
EVLA	Expanded Very Large Array
e-VLBI	Electronic VLBI
EVN	European VLBI Network
EXPReS	Express Production Real-time e-VLBI Service
FACH	Fuerza Aérea de Chile (Air Force of Chile) (Chile)
FAGS	Federation of Astronomical and Geophysical data analysis Services
FCN	Free Core Nutation
FEM	Finite Element Modeling
FES	Finite Element Solution
FESG	Forschungseinrichtung Satellitengeodäsie/Technical University of Munich (Germany)
FFI	Forsvarets ForskningsInstitutt (Norwegian Defence Research Establishment) (Norway)
FFT	Fast Fourier Transform
FFTS	Fast Fourier Transform Spectrometer
FGS	Forschungsgruppe Satellitengeodäsie (Germany)
FICN	Free Inner Core Nutation
FILA	FIRst LAsT
FINEP	Financiadora de Estudos e Projetos (Brazilian Innovation Agency) (Brazil)
FIR	Finite Impulse Response
FITS	Flexible Image Transport System
FOV	Field Of View

FPDP	Front Panel Data Port
FPGA	Field-programmable Gate Array
FS	Field System
FTP	File Transfer Protocol
FWF	Fonds zur Förderung der wissenschaftlichen Forschung (Austrian Science Fund)
GA	Geoscience Australia (Australia)
GALAXY	Giga-bit Astronomical Large Array with cross connect
GAPE	Great Alaska and Pacific Experiment
GARNET	GSI Advanced Radiotelescope NETwork (Japan)
GARR	Gruppo per l'Armonizzazione delle Reti della Ricerca (Italian Academic and Research Network) (Italy)
GARS	German Antarctic Receiving Station (Germany)
GASP	GLAST-AGILE Support Program
GBT	Green Bank Telescope (USA)
GCGO	Gilmore Creek Geophysical Observatory (USA)
GDR	altimeter Geophysical Data Record
GEMD	Geospatial and Earth Monitoring Division (Australia)
GeoDAF	Geodetic Data Archiving Facility (Italy)
GEX	Giga-bit series VLBI EXperiment
GFZ	GeoForschungsZentrum (Germany)
GGAO	Goddard Geophysical and Astronomical Observatory (USA)
GGFC	Global Geophysical Fluids Center
GGN	Global GPS Network
GGOS	Global Geodetic Observing System
GGP	Global Geodynamics Project
GICO	GIga-bit COrrrelator
GINS	Géodésie par Intégrations Numériques Simultanées
GIOVE	Galileo In-Orbit Validation Element
GISTM	GPS Ionospheric Scintillation and TEC Monitor
GIUB	Geodetic Institute of the University of Bonn (now IGGB) (Germany)
GLAST	Gamma ray Large Area Space Telescope (USA)
GLDAS	Global Land Data Assimilation System
GLONASS	GLObal NAvigation Satellite System (Russia)
GLORIA	GLObal Radio Interferometry Analysis
GMF	Global Mapping Function
GMPLS	Generalized MultiProtocol Label Switching
GMST	Greenwich Mean Sideral Time
GNS Science	Geological and Nuclear Sciences Research Institute (New Zealand)
GNSS	Global Navigation Satellite Systems
GOCE	Gravity field and steady-state Ocean Circulation Explorer
GOT	Goddard/Grenoble Ocean Tide
GOW	Geodetic Observatory Wettzell
GP-B	Gravity Probe B
GPS	Global Positioning System
GPT	Global Pressure and Temperature

---

GR	General Relativity
GRACE	Gravity Recovery and Climate Experiment (USA)
GREAT-ESF	Gaia Research for European Astronomy Training — European Science Foundation
GREF	German GPS REference network
GRGS	Groupe de Recherches de Géodésie Spatiale (France)
GSD	Geodetic Survey Division of Natural Resources Canada (Canada)
GSFC	Goddard Space Flight Center (USA)
GSI	Geospatial Information Authority of Japan (formerly Geographical Survey Institute) (Japan)
GSK	Generalized Spectral Kurtosis
GSOS	GPS Surface Observing System
GSS	Generator of Synchronization Signals
GST	Greenwich Sideral Time
HAMTIDE	Hamburg direct data Assimilation Methods for TIDEs
HartRAO	Hartebeesthoek Radio Astronomy Observatory (South Africa)
HAT-Lab	High Advanced Technology-Lab (Italy)
HEMT	High Electron Mobility Transistor
HF	High Frequency
HIA	Herzberg Institute for Astrophysics (Canada)
HIRLAM	High Resolution Limited Area Model
Honeywell TSI	Honeywell Technology Solutions Inc. (USA)
HOPS	Haystack Observatory Postprocessing System
HPBW	Half Power Beam Width
HPC	High Performance Compute
HSI	High Speed Input bus
HSIR	High Speed Input Replicated bus
HTS	High Temperature Superconductor
HTSI	Honeywell Technology Solutions Incorporated (USA)
HVAC	Heating, Ventilation, and Air Conditioning
IAA	Institute of Applied Astronomy (Russia)
IAG	International Association of Geodesy
IAPG	Institute of Astronomical and Physical Geodesy (Germany)
IAU	International Astronomical Union
IBGE	Instituto Brasileiro de Geografia e Estatística (Brazil)
IBM	International Business Machines Corporation (USA)
iBOB	Interconnect Break Out Board
ICRAR	International Centre for Radio Astronomy Research (Australia)
ICRF	International Celestial Reference Frame
ICRF2	2nd Realization of the International Celestial Reference Frame
ICRS	International Celestial Reference System
IDS	International DORIS Service
IDV	IntraDay Variability
IERS	International Earth Rotation and Reference Systems Service
IETF	Internet Engineering Task Force

IF	Intermediate Frequency
IGFN	Italian Space Agency GPS Fiducial Network (Italy)
IGFS2	second International Symposium of the Gravity Field of the earth
IGG	Institute of Geodesy and Geophysics (Austria)
IGGB	Institut für Geodäsie und Geoinformation der Universität Bonn (Germany)
IGGOS	Integrated Global Geodetic Observing System (now GGOS)
IGM	Instituto Geográfico Militar (Chile)
IGN	Institut Geographique National (France)
IGN	Instituto Geográfico Nacional (Spain)
IGS	International GNSS Service
IISGEO	International Institute for Space Geodesy and Earth Observation
I-JUSE	Institute of Japanese Union of Scientists and Engineers (Japan)
IKAROS	Interplanetary Kite-craft Accelerated by Radiation of the Sun (Japan)
ILRS	International Laser Ranging Service
IMC	Interface Module of Correlator
IMF	Isobaric Mapping Function
INACH	Institute for Antarctic Research Chile
INAF	Istituto Nazionale di Astrofisica (Italy)
INGV	Institute of Geophysics and Volcanology (Italy)
INPE	Instituto Nacional de Pesquisas Espaciais (Brazil)
InSAR	Interferometric Synthetic Aperture Radar
IP	Internet Protocol
IPWV	Integrated Precipitable Water Vapor
IRA	Istituto di RadioAstronomia (Italy)
IRAS	InfraRed Astronomy Satellite
IRASR	Institute for Radio Astronomy and Space Research (New Zealand)
IRIS	International Radio Interferometric Surveying
IRP	Invariant Reference Point
IRSR	Institute for Radiophysics and Space Research (New Zealand)
ISACCO	Ionospheric Scintillations Arctic Campaign Coordinated Observation
ISAS	Institute of Space and Astronautical Science (Japan)
ISBN	International Standard Book Number
ISI	Information Sciences Institute (USA)
ISV	Instantaneous State Vector
ITIS	Istituto di Tecnologia Informatica Spaziale (Italy)
ITRF	International Terrestrial Reference Frame
ITRS	International Terrestrial Reference System
ITSS	(Raytheon) Information Technology and Science Services (USA)
IUGG	International Union of Geodesy and Geophysics
IVOA	International Virtual Observatory Alliance
IVP	Invariant Point
IVS	International VLBI Service for Geodesy and Astrometry
IWV	Integrated Water Vapor
IYA	International Year of Astronomy
JADE	Japanese Dynamic Earth observation by VLBI



---

JARE	Japanese Antarctic Research Expedition (Japan)
JAXA	Japan Aerospace Exploration Agency (Japan)
JENAM	Joint European and National Astronomy Meeting
JGN	Japan Gigabit Network (Japan)
JGR	Journal of Geophysical Research
JHB	JoHannesBurg
JIVE	Joint Institute for VLBI in Europe
JLRA	Joint Laboratory for Radio Astronomy (China)
JMA	Japan Meteorological Agency (Japan)
JPL	Jet Propulsion Laboratory (USA)
JSPS	Japanese Society for the Promotion of Science (Japan)
JST	Japan Standard Time
KARAT	KAshima RAy-tracing Tools (Japan)
KARATS	KAshima RAy-Tracing Service (Japan)
KAREN	Kiwi Advanced Research and Education Network (New Zealand)
KASI	Korea Astronomy and Space Science Institute (Korea)
KAT	Karoo Array Telescope (South Africa)
KBR	K-Band Ranging
KEG	Kommission für Erdmessung und Glaziologie (Germany)
KPGO	Koike Park Geophysical Observatory (USA)
KPSS	Kwiatkowski-Phillips-Schmidt-Shin
KSP	KeyStone Project (Japan)
KSRC	Kashima Space Research Center (Japan)
KSTC	Kashima Space Technology Center
KTU	Karadeniz Technical University (Turkey)
KTU-GEOD	Karadeniz Technical University (KTU), Department of Geomatics Engineering (Turkey)
KVG	Korea VLBI system for Geodesy (Korea)
KVM	Keyboard, Video, and Mouse
KVN	Korean VLBI Network
LAB	Laboratoire d'Astrophysique de Bordeaux (France)
LAGEOS	LAser GEOdynamic Satellite
LAMOST	Large Sky Area Multi-object Fiber Spectroscopic Telescope (China)
LAREG	Laboratoire de Recherches en Géodésie (France)
LBA	Long Baseline Array (Australia)
LCP	Left Circular Polarization
LCS	Long baseline array Calibrator Survey
LD	Laser Diode
LEA	Lab of Ephemeris Astronomy (Russia)
LED	Light-Emitting Diode
LEIF	Large Equipment and Infrastructure Funding
LEO	Low Earth Orbit
LHC	Left Hand Circular
LIEF	Large Infrastructure and Equipment Funding
LINZ	Land Information New Zealand (New Zealand)

LLR	Lunar Laser Ranging
LNA	Low Noise Amplifier
LN MAG	Lab of New Methods in Astrometry and Geodynamics (Russia)
LO	Local Oscillator
LOC	Local Organizing Committee
LOD	Length Of Day
LPF	Low Pass Filter
LPI	Lebedev Physical Institute (Russia)
LRS	Laser Ranging System
LSB	Lower Side Band
LSC	Least Squares Collocation
LSF	Large Scale Facility
LSGER	Lab of Space Geodesy and Earth Rotation (Russia)
LSM	Least Squares Method
LSQM	Least Squares Method
MAO	Main Astronomical Observatory (Ukraine)
MARBLE	Multiple Antenna Radio-interferometry for Baseline Length Evaluation
MBH	Mathews/Bufett/Herring Nutation Model
MCB	Monitor and Control Bus
MCI	Monitor and Control Infrastructure
MDION	Multi-Dimensional IONosphere modeling
MEI	Multivariate ENSO Index
MERIT	Monitoring of Earth Rotation and Intercomparison of the Techniques of Observation and Analysis
METLAB	Microwave Energy Transmission LABORatory (Japan)
MEX	Mars Express
MIT	Massachusetts Institute of Technology (USA)
MITEQ	Microwave Information Transmission EQUIPMENT (USA)
MJD	Modified Julian Date
MLRO	Matera Laser Ranging Observatory (Italy)
MNHD	Mineral and Natural Hazard Division (Australia)
MOBLAS	MOBILE LASER
MODEST	MODEL and ESTimate
MOU	Memorandum of Understanding
MPI	Max-Planck-Institute (Germany)
MPIfR	Max-Planck-Institute for Radioastronomy (Germany)
MPM	Millimeter-wave Propagation Model
MRO	Mars Reconnaissance Orbiter
MRO	Metsähovi Radio Observatory (Finland)
MSL	Mars Science Laboratory
MTLRS	Modular Transportable Laser Ranging System
NAO	National Astronomical Observatories (China)
NAO	National Astronomical Observatory (Japan)
NAOC	National Astronomical Observatories of China (China)
NAOJ	National Astronomical Observatory of Japan (Japan)

---

NAR	Noise-Adding Radiometer
NASA	National Aeronautics and Space Administration (USA)
NASU	National Academy of Sciences of Ukraine (Ukraine)
NCAR	National Center for Atmospheric Research (USA)
NCEP	National Centers for Environmental Prediction (USA)
NCRIS	National Collaborative Research Infrastructure Strategy (Australia)
NDBC	National Data Buoy Center
NDRE	Norwegian Defence Research Establishment (Norway)
NEA	Near-Earth Asteroid
NENS	Near Earth Network Services
NEOS	National Earth Orientation Service (USA)
NEQ	Normal Equation System
NESDIS	National Environmental Satellite, Data, and Information Service (USA)
NetCDF	Network Common Data Form
NEXPreS	Novel EXploration Pushing Robust e-VLBI Services
NGII	National Geographic Information Institute (Korea)
NGS	National Geodetic Survey (USA)
NGSLR	Next Generation Satellite Laser Ranging
NICT	National Institute of Information and Communications Technology (Japan)
NII	National Institute of Informatics (Japan)
NIPR	National Institute of Polar Research (Japan)
NMA	Norwegian Mapping Authority (Norway)
NMF	Niell Mapping Function
NNR	No-Net-Rotation
NNT	No-Net-Translation
NOAA	National Oceanic and Atmospheric Administration (USA)
NOFS	U.S. Naval Observatory, Flagstaff Station (USA)
NORAD	North American Aerospace Defense Command
NOT	Nordic Optical Telescope
NRAO	National Radio Astronomy Observatory (USA)
NRCan	Natural Resources Canada (Canada)
NRF	National Research Foundation (South Africa)
NSF	National Science Foundation (USA)
NTT	New Technology Telescope (Chile)
NTT	Nippon Telegraph and Telephone Corporation (Japan)
NVI	NVI, Inc. (USA)
NWP	Numerical Weather Prediction
NySMAC	Ny-Ålesund Science Managers Committee
OAM	Observatorio Astronómico de Madrid (Spain)
OAN	Observatorio Astronómico Nacional (Spain)
OCA	Observatoire de la Côte d'Azur (France)
OCARS	Optical Characteristics of Astrometric Radio Sources
OPAR	Observatoire de Paris (France)
OPC	(IVS) Observing Program Committee
ORCA	Optical ReCeiver/splitter/Amplifier

OS	Operating System
OSI	Operator Software Impact
OSO	Onsala Space Observatory (Sweden)
OTL	Ocean Tidal Loading
PARNASSUS	Processing Application in Reference to NICT's Advanced Set of Softwares Usable for Synchronization
PASJ	Publications of the Astronomical Society of Japan
PASP	Publications of the Astronomical Society of the Pacific
PATA	Parallel Advanced Technology Attachment
PCAL	Phase CALibration
PCB	Printed Circuit Board
PCU	Power Control Unit
PEACESAT	Pan-Pacific Education and Communication Experiments by Satellite
PERSAC	Pulkovo EOP and Reference Systems Analysis Center (Russia)
PF	Processing Factor
PFB	Polyphase Filter Bank
PIVEX	Platform Independent VLBI EXchange format
PLC	Programmable Logic Controller
PLO	Phase Locked Oscillator
PM	Polar Motion
PMD	Politecnico di Milano DIAR (Italy)
PNR	Peak to Noise Ratio
POLARIS	POLar motion Analysis by Radio Interferometric Surveying
POP	Point of Presence
PPN	Parameterized Post-Newtonian
PPP	Precise Point Positioning
PRAO	Pushchino Radio Astronomy Observatory (Russia)
PRARE	Precise RAnge and Range-rate Equipment
PSD	Power Spectrum Density
QDOR	Quadruply Differenced One-way Ranging
QRFH	Quad Ridge Feed Horn
QRHA	Quad-Ridge Horn Antenna
QZSS	Quasi Zenith Satellite System (Japan)
RAEGE	Red Atlántica de Estaciones Geodinámicas y Espaciales
RAS	Russian Academy of Sciences (Russia)
RCP	Right Circular Polarization
RCU	Receiver Control Unit
RDBE	Roach Digital Back End
RDV	Research and Development sessions using the VLBA
RedCLARA	CLARA (Cooperación Latino Americana de Redes Avanzadas) network
REFAG	Reference Frames for Applications in Geosciences
REGINA	REseau GNSS pour l'IGS et la Navigation (GNSS Receiver Network for IGS and Navigation) (France)
REPA	REsidual Plotting and Ambiguity resolution
REUNA	Red Universitaria Nacional (Chile)

---

RF	Radio Frequency
RFCN	Retrograde Free Core Nutation
RFI	Radio Frequency Interference
RHC	Right Hand Circular
ROACH	Reconfigurable Open Architecture Computing Hardware
ROEN	Rádio-Observatório Espacial do Nordeste (Brazil)
ROM	Real Observatorio de Madrid (Spain)
RRFID	Radio Reference Frame Image Database
RS-232C	Recommended Standard-232C
RT	Radio Telescope
RTK	Real-Time Kinematic
RTNF	Radio Telescope National Facility (New Zealand)
RTP	Real-Time Protocol
RTW	Radio Telescope in Wettzell
SAC	Satellite Application Centre
SAGE	Small Advanced Geodetic e-VLBI System
SAI	Sternberg State Astronomical Institute (Russia)
SAN	Storage Area Network
SAR	Synthetic Aperture Radar
SATA	Serial Advanced Technology Attachment
SBIR	Small Business Innovation Research
SCG	SuperConducting Gravimeter
SCNS	Space Communications Network Services
SCR	Silicon Controlled Rectifier
SDK	Software Development Kit
SDM	Signal Distribution Modules
SDSS	Signal Distribution and Synchronization System
SEAC	Sociedad Española de Aplicaciones Cibernéticas (Spain)
SEFD	System Equivalent Flux Density
SETI	Search for Extraterrestrial Intelligence
SGL	Space Geodynamics Laboratory (Canada)
SGT	Stinger Ghaffarian Technologies (USA)
SHAO	SHanghai Astronomical Observatory (China)
SI	Special Issue
SI	Structure Index
SIMD	Single Instruction Multiple Data
SINEX	Solution INdependent EXchange
SISMA	Seismic Information System for Monitoring and Alert
SK	Spectral Kurtosis
SKA	Square Kilometre Array
SLR	Satellite Laser Ranging
SMART	Small Missions for Advanced Research and Technology
SMHI	Swedish Meteorological and Hydrological Institute (Sweden)
SNAP	Standard Notation for Astronomical Procedures
SNR	Signal to Noise Ratio

SNSN	Swedish National Seismic Network (Sweden)
SOD	Site Occupation Designator
SOSW	Satellite Observing System Wettzell (Germany)
SPb	Saint-Petersburg (Russia)
SPbU	Saint-Petersburg University (Russia)
SPEED	Short Period and Episodic Earth rotation Determination
SPU	Saint-Petersburg University (Russia)
SPV	Signal Path Variation
SRIF	Square Root Information Filter
SRT	Sardinia Radio Telescope (Italy)
SRTM	Shuttle Radar Topography Mission
SSA	Singular Spectrum Analysis
SSAI	Science Systems and Applications, Inc. (USA)
STDN	Satellite Tracking Data Network (NASA)
STEREO	Solar TERrestrial RELations Observatory
SU	Station Unit
SVD	Singular Value Decomposition
SvRAO	Svetloe Radio Astronomical Observatory (Russia)
SWT	SW Technology (USA)
SYRTE	SYstème de Références Temps-Espace
TAC	Totally Accurate Clock
TAI	Temps Atomique International (International Atomic Time)
TAL	Terrestrial Air Link
TANAMI	Tracking Active galactic Nuclei with Austral Milliarcsecond Interferometry (Australia)
TanDEM-X	TerraSAR-X add-on for Digital Elevation Measurement (Germany)
TAO	Telecommunications Advanced Organization (Japan)
TCE	Time Comparison Equipment
TDC	(IVS) Technology Development Center
TEC	Total Electron Content
TECU	Total Electron Content Units
TEM	Transverse ElectroMagnetic
TEMPO	Time and Earth Motion Precision Observations
TENET	Tertiary Education and Research Network of South Africa (South Africa)
TERENA	Trans-European Research and Education Networking Association
TerraSAR	Terra Synthetic Aperture Radars (Germany)
TerraSAR-X	Terra Synthetic Aperture Radars X-band (Germany)
TID	Traveling Ionospheric Disturbance
TIGA-PP	GPS TIdE GAUge Benchmark Monitoring Pilot Project
TIGO	Transportable Integrated Geodetic Observatory (Germany, Chile)
TLE	Two Line Elements
TLRS	Transportable Laser Ranging System
TMR	Training and Mobility of Researchers program of the European Community
ToR	IVS Terms of Reference
TOW	Technical Operations Workshop

---

TRF	Terrestrial Reference Frame
TSPM	Test Synchronization Pulsar gating Module
TTW	TWIN-Telescope Wettzell (Germany)
TU	Technische Universität
TUM	Technical University of Munich (Germany)
TWA	Travel Wave Antennas
TWSTFT	Two-Way Satellite Time and Frequency Transfer
UAO	Urumqi Astronomical Observatory (China)
UBB	Universidad del Bío Bío (Chile)
UC Berkeley	University of California, Berkeley (USA)
UD	Upper Diagonal
UDC	Up-Down Converter
UEN	Up East North
UMTS	Universal Mobile Telecommunications System
UNAVCO	University NAVSTAR Consortium
UNICAMP	Universidade Estadual de Campinas (Brazil)
UNISEC	UNiversity Space Engineering Consortium (Japan)
UNITEC-1	UNisec Technological Experiment Carrier-1 (Japan)
UREO	Ultra-Rapid Earth Orientation
URSI	Union Radio-Scientifique Internationale
USB	Unified S-Band
USB	Upper Side Band
USNO	United States Naval Observatory (USA)
USP	Universidade de São Paulo (Brazil)
USS	Uniform Sky Strategy
UT	Universal Time
UT1	Universal Time
UTAS	University of TASmania (Australia)
UTC	Coordinated Universal Time
u-VLBI	Ultra High Sensitivity VLBI
UWB	Ultra WideBand
V2PEG	VLBI2010 Project Executive Group
VC	Video Converter
VCS	VLBA Calibrator Survey
VDBE	VLBA Digital BackEnd
VDIF	VLBI Data Interchange Format
VEGA	Venus-Halley project (Russia)
VERA	VLBI Exploration of Radio Astrometry
VEX	Venus EXpress
VEX	VLBI EXchange format
VHDL	Very High-level Design Language
VieVS	Vienna VLBI Software
VLA	Very Large Array (USA)
VLBA	Very Long Baseline Array (USA)
VLBI	Very Long Baseline Interferometry

VMF	Vienna Mapping Function
VO	Virtual Observatory
VSI	VLBI Standard Interface
VSI-C	Metsähovi VSI-H Converter board
VSI-H	VLBI Standard Interface Hardware
VSI-S	VLBI Standard Interface Software
VSN	Volume Serial Number
VSOP	VLBI Space Observatory Program
VSR	VLBI Science Recorder
VSSP	Versatile Scientific Sampling Processor
VTEC	Vertical Total Electron Content
VTM	Vienna TEC (Total Electron Content) Model
VTP	VLBI Transport Protocol
VTRF	VLBI Terrestrial Reference Frame
WACO	WAshington COrrrelator (USA)
WEBT	Whole Earth Blazar Telescope
WEGENER	Working Group of European Geoscientists for the Establishment of Networks for Earth-science Research
WG	Working Group
WGS84	World Geodetic System 1984
WIDAR	Wideband Interferometric Digital ARchitecture
WLRS	Wettzell Laser Ranging System (Germany)
WMAP	Wilkinson Microwave Anisotropy Probe
WVR	Water Vapor Radiometer
WVSR	Wideband VLBI Science Recorder
WWW	World Wide Web
XDM	eXperimental Development Model
ZcRAO	Zelenchukskaya Radio Astronomical Observatory (Russia)
ZTD	Zenith Total Delay
ZWD	Zenith Wet Delay





**REPORT DOCUMENTATION PAGE**

*Form Approved*  
OMB No. 0704-0188

The public reporting burden for this collection of information is estimated to average 1 hour per response, including the time for reviewing instructions, searching existing data sources, gathering and maintaining the data needed, and completing and reviewing the collection of information. Send comments regarding this burden estimate or any other aspect of this collection of information, including suggestions for reducing this burden, to Department of Defense, Washington Headquarters Services, Directorate for Information Operations and Reports (0704-0188), 1215 Jefferson Davis Highway, Suite 1204, Arlington, VA 22202-4302. Respondents should be aware that notwithstanding any other provision of law, no person shall be subject to any penalty for failing to comply with a collection of information if it does not display a currently valid OMB control number.

**PLEASE DO NOT RETURN YOUR FORM TO THE ABOVE ADDRESS.**

<b>1. REPORT DATE (DD-MM-YYYY)</b> 30-06-2012		<b>2. REPORT TYPE</b> Technical Publication		<b>3. DATES COVERED (From - To)</b>	
<b>4. TITLE AND SUBTITLE</b> International VLBI Service for Geodesy and Astrometry 2011 Annual Report				<b>5a. CONTRACT NUMBER</b>	
				<b>5b. GRANT NUMBER</b>	
				<b>5c. PROGRAM ELEMENT NUMBER</b>	
<b>6. AUTHOR(S)</b> Karen D. Baver, Dirk Behrend				<b>5d. PROJECT NUMBER</b>	
				<b>5e. TASK NUMBER</b>	
				<b>5f. WORK UNIT NUMBER</b>	
<b>7. PERFORMING ORGANIZATION NAME(S) AND ADDRESS(ES)</b> Goddard Space Flight Center Greenbelt, MD 20771				<b>8. PERFORMING ORGANIZATION REPORT NUMBER</b>	
<b>9. SPONSORING/MONITORING AGENCY NAME(S) AND ADDRESS(ES)</b> National Aeronautics and Space Administration Washington, DC 20546-0001				<b>10. SPONSORING/MONITOR'S ACRONYM(S)</b> NASA GSFC	
				<b>11. SPONSORING/MONITORING REPORT NUMBER</b> NASA/TP-2012-217505	
<b>12. DISTRIBUTION/AVAILABILITY STATEMENT</b> Unclassified-Unlimited, Subject Category: 46 Report available from the NASA Center for Aerospace Information, 7115 Standard Drive, Hanover, MD 21076. (443) 757-5802					
<b>13. SUPPLEMENTARY NOTES</b> Karen Baver, NVI, Inc., Greenbelt, MD; Dirk Behrend, NVI, Inc., Greenbelt, MD					
<b>14. ABSTRACT</b> This volume of reports is the 2011 Annual Report of the International VLBI Service for Geodesy and Astrometry (IVS). The individual reports were contributed by VLBI groups in the international geodetic and astrometric community who constitute the components of IVS. The 2011 Annual Report documents the work of these IVS components over the period January 1, 2011 through December 31, 2011. The reports document changes, activities, and progress of the IVS. The entire contents of this Annual Report also appear on the IVS Web site at <a href="http://ivscc.gsfc.nasa.gov/publications/ar2011">http://ivscc.gsfc.nasa.gov/publications/ar2011</a> .					
<b>15. SUBJECT TERMS</b> Geodesy, astrometry, VLBI, geophysics, Earth orientation, very long baseline interferometry, radio astronomy, geodynamics, reference frames, terrestrial reference frame, celestial reference frame, length of day, Earth system science, Earth rotation.					
<b>16. SECURITY CLASSIFICATION OF:</b>			<b>17. LIMITATION OF ABSTRACT</b>	<b>18. NUMBER OF PAGES</b>	<b>19a. NAME OF RESPONSIBLE PERSON</b>
<b>a. REPORT</b>	<b>b. ABSTRACT</b>	<b>c. THIS PAGE</b>			Chopo Ma
Unclassified	Unclassified	Unclassified	Unclassified	366	<b>19b. TELEPHONE NUMBER (Include area code)</b> (301) 614-6101

Back cover:

*A major step in technology development is the Mark 6 data system, which is being developed at Haystack Observatory. Mark 6 will support sustained recording and playback of data at a rate of 16 Gbps. The back cover shows the prototype for the Mark 6 data recorder rack. Photo courtesy of Alan Whitney.*

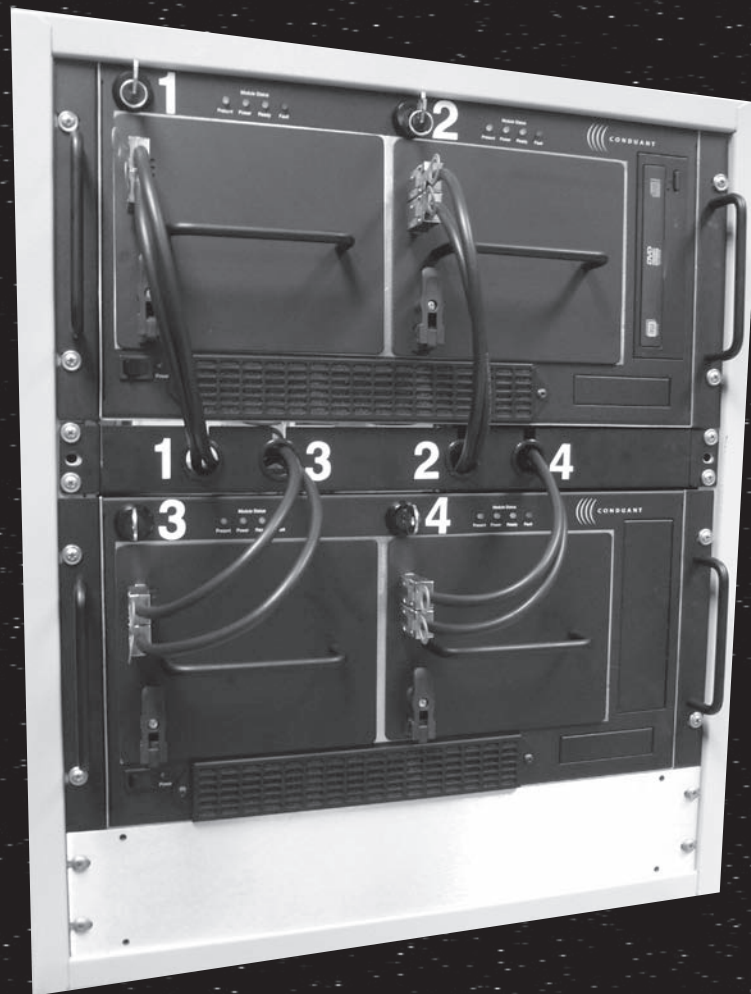
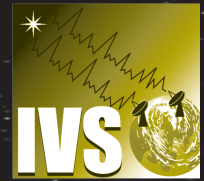

International VLBI Service for Geodesy and Astrometry

IVS Coordinating Center  
NASA Goddard Space Flight Center  
Code 698.2  
Greenbelt, MD 20771

<http://ivscc.gsfc.nasa.gov>  
[ivscc@ivscc.gsfc.nasa.gov](mailto:ivscc@ivscc.gsfc.nasa.gov)  
phone: 301-614-5939  
fax: 301-286-0239