

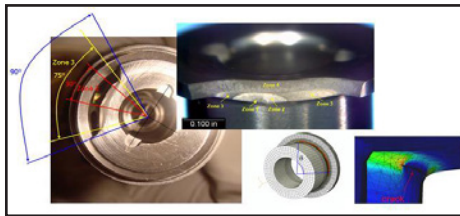

National Aeronautics and
Space Administration

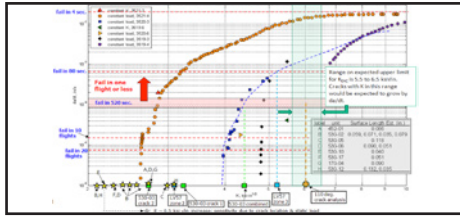
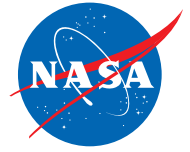

Marshall Space Flight Center

damage tolerance assessment branch

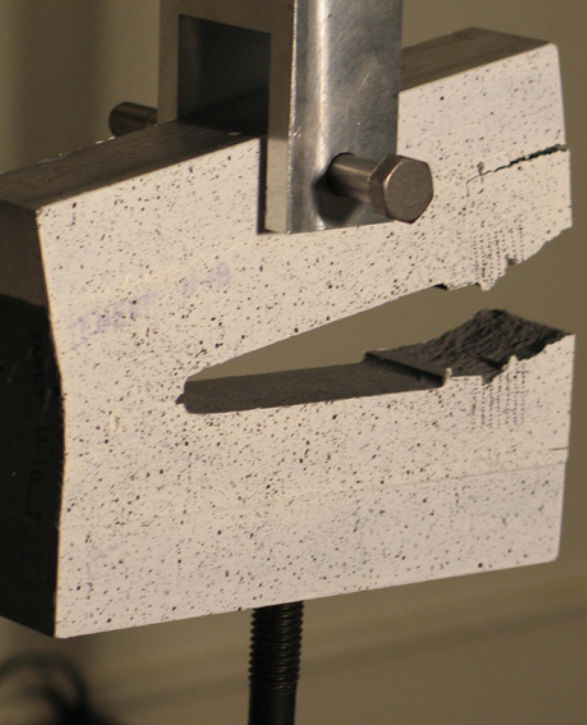

Fracture Test of Solid Motor Inert Propellant

Infrared Thermography of the External Tank Nosecone



Eddy Current Testing of a hole

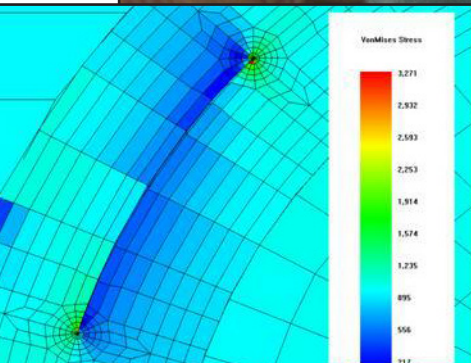

Close-up of 45° crack with Von Mises stress map display and 100x exaggerated deformation.

EM20 Damage Tolerance Assessment Branch

.....



The Damage Tolerance Assessment Branch evaluates the ability of a structure to perform reliably throughout its service life in the presence of a defect, crack, or other form of damage. Such assessment is fundamental to the use of structural materials and requires an integral blend of materials engineering, fracture testing and analysis, and nondestructive evaluation. The vision of the Branch is to increase the safety of manned space flight by improving the fracture control and the associated nondestructive evaluation processes through development and application of standards, guidelines, advanced test and analytical methods.

The Branch also strives to assist and solve non-aero-space related NDE and damage tolerance problems, providing consultation, prototyping and inspection services.

Damage Tolerance Assessment Branch Contacts

Dr. Wayne R. Gamwell, Branch Chief
wayne.r.gamwell@nasa.gov, 256-544-2592

Mr. Mike Suits, Deputy Branch Chief
mike.suits@nasa.gov, 256-544-8336

EM20 Nondestructive Evaluation Team

Nondestructive Evaluation is a wide group of analysis techniques used in science and industry to evaluate the properties of a material, component or system without causing damage. The terms nondestructive testing (NDT), nondestructive inspection (NDI), and nondestructive evaluation (NDE) are also commonly used to describe this technology. Because NDE does not permanently alter the article being inspected, it is a highly-valuable technique that can save both money and time in product evaluation, troubleshooting, and research. Common NDE methods include ultrasonic, magnetic-particle, liquid penetrant, radiographic, eddy-current, thermographic, x-ray computed tomographic and shearographic testing. NDE is a commonly-used tool in forensic engineering, mechanical engineering, electrical engineering, civil engineering, systems engineering, aeronautical engineering, medicine, and art.

Nondestructive Evaluation Mission

The mission of the NDE Team is to develop and maintain an effective sustaining engineering capability to responsively support MSFC and NASA spaceflight hardware by utilizing the best available NDE tools, which are then applied to materials and structures to verify the required integrity and to reliability detect characteristic flaws. This evaluation is accomplished without causing physical or chemical changes to the part being inspected, or otherwise impairing its adequacy for operational service. The NDE capability spans both metallic and non-metallic materials and structures. The NDE Team also works integrally with the Damage Tolerance Assessment Team to provide quantified initial flaw screening capability for fracture analysis safe-life determination in metallic structures and to help determine the effects of defects in damage tolerant non-metallic structures.

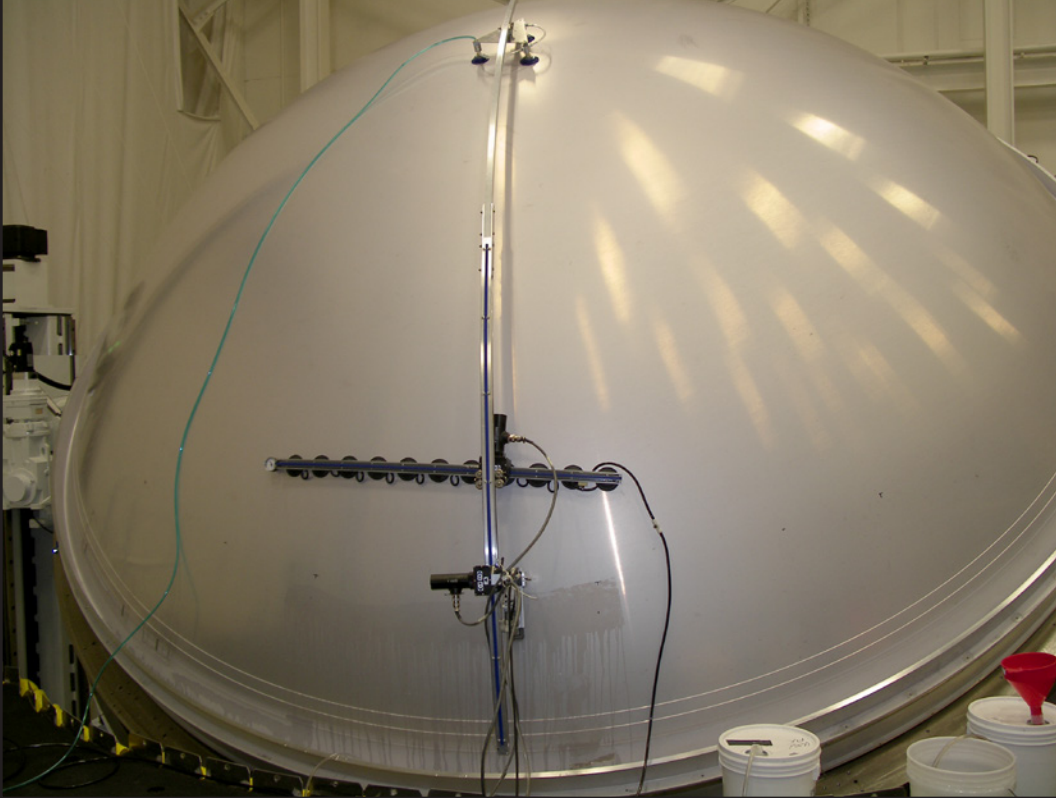

Phased Array Ultrasonic Testing of a Common Bulkhead.

Recent Activities

- Development of on-pad radiographic techniques for detection and evaluation of cracked 2090 aluminum stringers on the Space Shuttle External Tank (ET).
- Development of NDE for locating defects in the spray-on-foam-insulation of the Space Shuttle ET.
- Development of eddy current testing techniques for Space Shuttle Main Engine Flow Liners
- Development of thermographic testing techniques for cold wall leak detection of the Space Shuttle Main Engine.
- Development of phased array ultrasonic testing for friction stir welding and friction stir plug welding.

REACTION		NEWTON'S 3 RD LAW	ACTION		
RESPONSE/OUTPUT		NDE METHOD	INPUT		
VISIBLE BLEEDOUT	Penetrant (PT)		CAPILLARY	MECHANICAL	
RESONANCE	Mechanical Impedance Analysis (MIA)		COMPRESSION / TENSION		
MEASURED ULTRASOUND	Acoustic Emission		PRESSURE		
SURFACE DISPLACMENT	Shearography (SH)		ATMOSPHERIC		
TEMPERATURE	Thermography (IRT)		HEAT		
MEASURED ULTRASOUND	Laser Ultrasonics (Laser UT)		LIGHT		
	Ultrasonics (UT)/Phased Array UT		SOUND		
LEAKAGE FIELD	Magnetic Particle (MT)		INDUCTION		ELECTRICAL
FIELD IMPEDANCE CHANGE	Eddy Current (ET)				
	Electromagnetic Acoustical				
VOLTAGE CHANGE	Electrical Potential Drop (da dN)				
DIELECTRIC DIFFERENCES	Microwave/Millimeter Wave (MMW)			SPECTRUM	
DIELECTRIC DIFFERENCES	Terahertz (THz)				
IMAGE	Visible				
DENSITY PHOTON COUNT	Computed Tomography (CT)				
DENSITY PHOTON COUNT	Backscatter X-Ray				
LATENT FILM DENSITY	Radiographic (RT)			MAGNETIC	

VISUAL

PHYSICS

ENERGY

LOAD

INDUCTION

SPECTRUM

Nondestructive Evaluation Methods Development at Marshall

- Evaluate the structural integrity of objects, materials, and systems for internal and external defects without impairing its future usefulness.
- The NDE team works problems from technique development to demonstration to implementation and finally integration with production tooling and process flow.

The MSFC NDE team includes the following endeavors:

- Composite materials screening and advanced single and multi-layer bondline interrogation.
- Supports advanced Friction Stir Weld development, providing process verification.
- Supports mechanical properties allowables testing.
- Supports Agency-wide working groups in NDE including the NASA NDE Working Group (NNWG), the NASA Engineering Safety Center (NESC) NDE Technical Discipline Team, the Chief Engineer's NDE Technical Specialist Team and

the NASA standards office for NDE requirements documents.

- Supports the development and qualification of test articles to provide clear and rational NDE and proof logic.
- Develops large scale automated NDE processes.
- Develops verification, validation and certification programs for advanced NDE methods by proper inspector training and validated probability of detection studies.



Microwave/Millimeter Wave Testing

- Active American Society of Nondestructive Testing (ASNT) Certifications in all conventional methods as well as in-house NAS-410 certification of inspectors.

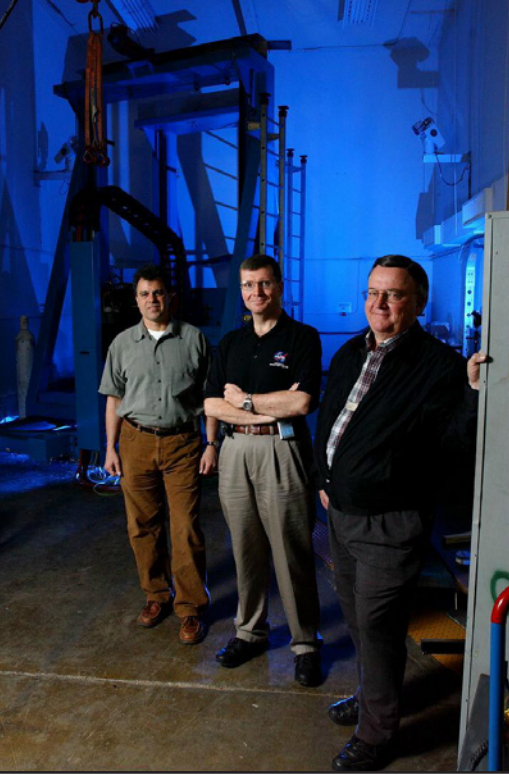

Computed Tomography Testing

At Marshall the Nondestructive Evaluation Team provides:

- The innovative application of conventional and advanced NDE methods and processes to manned and unmanned space flight systems, components and materials.
- Leadership in the development of NASA NDE Standards and NDE Requirements for manned flight systems.
- Consultation and expertise for anomaly investigations in support of manned flight systems.
- Active membership on the MSFC Fracture Control Board.
- One of the most advanced microwave NDE laboratories in the world.
- Portable real-time radiography for dynamic motor test environments.
- Conventional NDE services utilizing state-of-the-art ultrasound, radiography, eddy current fluorescent dye penetrant, magnetic particle, thickness measurement, bond testing, and borescopic (visual) systems.
- Advanced NDE services such as Terahertz imaging, thermography, backscatter x-ray, laser ultrasound, laser shearography, high-resolution/high energy computed tomography.
- The design and validation of capability studies for new NDE applications.
- The design and fabrication of realistic NDE reliability and calibration standards.

NDE Spin-offs

The following are just a few of the non-aerospace related tasks that the MSFC NDE team has worked:

- Thermography of aircraft brake disks.
- Ultrasonic leak detection of diesel engine components.
- Radiography testing of packages looking for explosives.
- Eddy Current and penetrant testing of aircraft parts.
- Eddy current of bolts holding Saturn V to its display fixture.
- Ultrasonic testing of helicopter swash plates and rotor components.
- Computed tomography of a car tires/parts, logs, time capsule, fossils.
- Ultrasonic testing on bond lines in Department of Defense Missiles.
- Laser shearography and ultrasonic testing on graphite golf shafts.

Nondestructive Evaluation

Team Contact

Mr. James Walker, Team Lead
james.l.walker@nasa.gov, 256-961-1784

EM20 Damage Tolerance Team

Damage Tolerance is a property of a structure relating to its ability to sustain defects safely until repair can be affected to meet usage requirements. The approach to engineering design to account for damage tolerance is based on the assumption that flaws can exist in any structure and such flaws sometimes propagate with usage. This approach is commonly used in aerospace engineering to manage the extension of cracks in structures through the application of the principles of fracture mechanics. A structure is considered to be damage tolerant if a maintenance program has been implemented that will result in the detection and repair of manufacturing defects, accidental damage, and fatigue cracking before such damage reduces the residual strength of the structure below an acceptable limit, or if the structure can meet service life requirements in the presence of a defect without repair.

Damage Tolerance Mission

The mission of the Damage Tolerance Team is to develop and maintain an effective sustaining engineering capability to responsively support MSFC and NASA spaceflight hardware by utilizing the best available fracture assessment tools and theories for thorough, accurate, and decisive solutions to engineering problems. The Team also pursues further development of engineering capability in damage tolerance testing and analysis to be implemented in assessment of issues facing MSFC and NASA programs.



Unanticipated Sample Failures Indicating Notch Sensitivity in Hydrogen

Recent Activities

- Failure analysis and test evaluation for debris liberation estimates supporting Shuttle Main Propulsion System valve fracture.
- Material test data evaluation supporting Shuttle External Tank Stiffener Rib fracture.
- Computation of acceptable disbond sizes for a cryogenic tank common bulkhead honeycomb sandwich structure.
- Determination of the critical defect location in a friction stir plug weld configuration for a propellant tank structure.
- Understanding of impact damage influence on the design of an interstage honeycomb thrust structure.

Damage Tolerance/Fracture Control and Analysis at Marshall

- Material characterization planning, data evaluation, and generation of design curves for metallic fracture and composites damage tolerance data.
- Analytical predictions in fracture mechanics for metallic hardware and residual strength for composite hardware.
- Component test objectives for damage evaluation and proof test.
- Fracture control and damage tolerance guidance for mitigation of failure due to defects or damage.

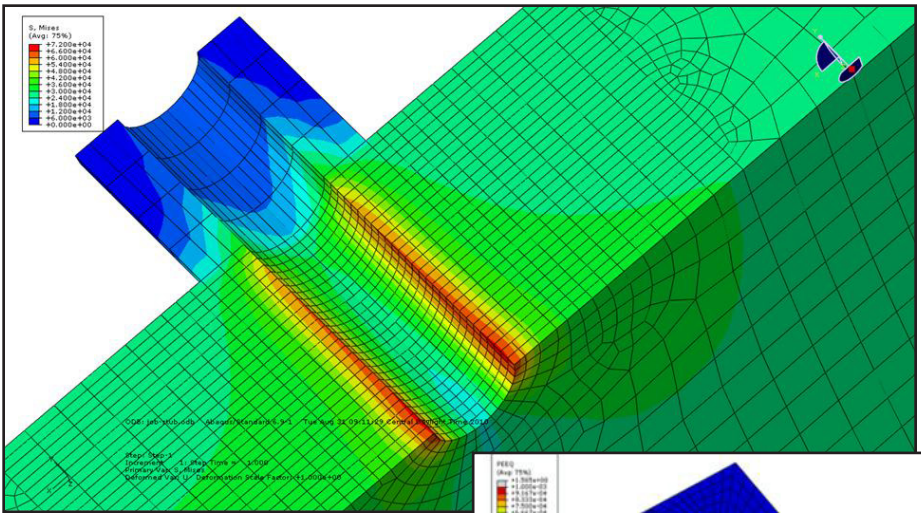

Finite Element Predictions for a Pressure Vessel Nozzle Interface

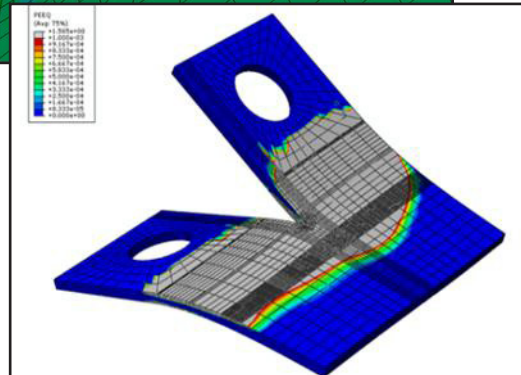

Finite Element Analysis of Mode III Fracture

The MSFC Damage Tolerance Team provides:

- Customized experimental techniques developed to assess toughness and fatigue crack growth in metallic materials, as well as damage tolerance of structures or components under unique loads and environments.
- Development of methodologies for experimentally assessing damage tolerance of solid composite laminates and honeycomb cored composite structures.
- Advanced analysis of fracture and fatigue in metallic structures using finite element and boundary element techniques.
- Structural assessment in accordance with all common codes and criteria (e.g., NASGRO®, API, or R6 failure assessment diagrams, constraint-corrected J_{Ic} , etc.)
- Specialized fracture analysis for short-life, high-stress components commonly found in launch vehicle applications.
- Development of advanced analysis software and techniques applicable to launch vehicle structures and materials.
- Consultation on fracture control implementation for new and advanced programs at MSFC and throughout NASA.
- Chairmanship and technical support for the MSFC Fracture Control Board.
- Development and refinement of NASA and industry guidelines and standards.
- Emphasis on innovative approaches to the implementation of fracture control for advanced materials and structures.
- Support to the NASA Engineering and Safety Center (NESC).



Failed Compression-After-Impact Specimen

Damage Tolerance Spin-offs

The following represent a few of the activities pursued to advance engineering capability in damage tolerance assessment:

- Support for development of finite element modules for integration with FEA Crack Software.
- Support for development of integration between the NASGRO® and FASTRAN Analysis Codes.
- Support for investigations into delamination effects in Aluminum-Lithium alloys.
- Support for investigations into boundary element and finite element integrated crack turning predictions.

Damage Tolerance Team Contact

Mr. Wayne Gregg, Team Lead
wayne.gregg@nasa.gov, 256-544-5501

National Aeronautics and Space Administration
George C. Marshall Space Flight Center
Huntsville, AL 35812
www.nasa.gov/marshall

www.nasa.gov