

HIGH FIDELITY SIMULATIONS OF PLUME IMPINGEMENT TO THE INTERNATIONAL SPACE STATION

Forrest E. Lumpkin III, NASA Johnson Space Center
Jeremiah J. Marichalar, Jacobs Technology – ESCG
Benedicte D. Stewart, MTS Inc.
Houston, TX

ABSTRACT

With the retirement of the Space Shuttle, the United States now depends on recently developed commercial spacecraft to supply the International Space Station (ISS) with cargo. These new vehicles supplement ones from international partners including the Russian Progress, the European Autonomous Transfer Vehicle (ATV), and the Japanese H-II Transfer Vehicle (HTV). Furthermore, to carry crew to the ISS and supplement the capability currently provided exclusively by the Russian Soyuz, new designs and a refinement to a cargo vehicle design are in work. Many of these designs include features such as nozzle scarfing or simultaneous firing of multiple thrusters resulting in complex plumes. This results in a wide variety of complex plumes impinging upon the ISS. Therefore, to ensure safe “proximity operations” near the ISS, the need for accurate and efficient high fidelity simulation of plume impingement to the ISS is as high as ever. A capability combining computational fluid dynamics (CFD) and the Direct Simulation Monte Carlo (DSMC) techniques has been developed to properly model the large density variations encountered as the plume expands from the high pressure in the combustion chamber to the near vacuum conditions at the orbiting altitude of the ISS. Details of the computational tools employed by this method, including recent software enhancements and the best practices needed to achieve accurate simulations, are discussed. Several recent examples of the application of this high fidelity capability are presented. These examples highlight many of the real world, complex features of plume impingement that occur when “visiting vehicles” operate in the vicinity of the ISS.

INTRODUCTION

The International Space Station (ISS) is a large and complex spacecraft, assembled in orbit from components delivered on multiple launches. In addition, supplies including propellant, scientific equipment, nitrogen and oxygen gases, water, and food need to be continuously replenished. As such, proximity operations (rendezvous, docking, berthing, and departure) of a wide variety of spacecraft with the ISS are key part of the vehicle’s design and concept of operations. During proximity operation, spacecraft must fire reaction control system (RCS) rocket engines to control their position and attitude relative to the ISS. The resulting plumes from RCS engine firings present a potential risk to the ISS due to elevated structural and heat loads that may damage the ISS when the RCS plumes impinge upon it. Therefore, sufficient knowledge of the RCS flow fields and the resulting impingement pressures and heat rates are necessary when designing the proximity operations for these so-called “visiting vehicles”. As a result, constraints including the allowable thruster firing locations and orientations relative to ISS, allowable thruster firing duration, and the required timing between subsequent firings of the thruster are included in the design details of these proximity operations. These constraints are incorporated in flight rules and affect the flight control logic used on the spacecraft.

The Applied Aeroscience and CFD Branch at the NASA Johnson Space Center (NASA-JSC) is responsible for ensuring that adequate flow field models exist for evaluation of the plume environments associated with the various visiting vehicles. In addition, the branch develops and supplies models for assessing plume impingement effects such as impingement pressure and heating. The Applied Aeroscience and CFD Branch then supplies these models to other organizations. For example, the Boeing ISS Loads and Dynamics team employs the models to assess the structural effects of plume impingement. For plume impingement heating, the branch itself assesses the heat rates, heat loads, and ISS thermal response, and therefore is, for this application, its own customer for the models.

The vast majority of plume impingement assessments for both impingement pressure and impingement heating employ engineering math models to provide rapid results. While high fidelity computational modeling provides more precise information, the computational cost would be prohibitive to apply to all the necessary cases. Many trajectories covering a wide range of parameters such as spacecraft mass properties for both nominal and off-nominal scenarios must be assessed, and each trajectory may have dozens to hundreds of plume firings. Therefore, an engineering approach assessing plume impingement effects is necessary as a practical matter. Such an approach has been developed at NASA-JSC and applied over a two-decade period dating from the Shuttle-Mir Program through the assembly of the ISS to today's ISS operations. High fidelity modeling has been used as a tool to develop, assess, and supplement, when certain assumptions break down, the engineering models.

To further understand the role played by high fidelity modeling, the basics of the engineering methodology will now be described. The engineering approaches used to assess plume impingement consist of two steps. The first step is to estimate the flow parameters such as density, velocity, and dynamic pressure for the plume flow field undisturbed by the impingement target. The required math models are based upon the semi-empirical source flow assumption. The source flow assumption states that when sufficiently far downstream in the plume, the fluxes of mass, momentum, and energy appear to have emanated from a single point in space, the so-called source. With this assumption, these fluxes must be proportional to $1/r^2$ where r is the distance from the source. The dependence of the fluxes upon the other independent spatial variables must be determined empirically. For a general case, such as a "scarfed" nozzle, there are two additional spatial variables, typically referred to with the symbols θ and ϕ (i.e. spherical co-ordinates). This reduces to the single variable θ when the nozzle and flow field are axis-symmetric. The second step is an impingement assessment step where the size, shape, and orientation of the impingement target together with plume flow values are used to estimate impingement coefficients. As a simple example, the modified Newtonian method may be used to compute the pressure coefficient at the impingement point. The impingement pressure is then determined by multiplying the dynamic pressure from the source flow model developed in the first step with this modified Newtonian pressure coefficient. In the NASA-JSC approach, models which bridge the modified Newtonian pressure, appropriate for continuum hypersonic flow, with the value for free molecular flow are applied to more accurately capture the appropriate physics. Similar techniques are used in estimating the impingement shear stress and the impingement heat rate. Assumptions such as line of sight shading and superposition of multiple plume flow fields are often applied with care to approximate respectively the real world complications of one component of ISS "shading" another from the plume and the effect of more than one RCS engine firing at a time. Care is necessary, as these assumptions are known to not be conservative. Therefore, when these assumptions are employed in an effort to approximate real world complications, additional factors or increments must be applied to ensure the assessment bounds the worst case.

High fidelity assessments are a key tool in both building the engineering math models and assessing their performance in complex, real world, plume impingement scenarios that often occur during actual or planned ISS proximity operations. NASA-JSC has developed an approach that uses Navier-Stokes based computational fluid dynamics (CFD) and the Direct Simulation Monte Carlo (DSMC) method to simulate on-orbit plumes and plume impingement. CFD may be used separately or in combination with DSMC. For example, CFD is often used to simulate the nozzle and plume flow field, and the results are used to determine the dependence of the source flow model on the spatial variables θ and ϕ referenced in the preceding paragraph. This is especially important for the complex plumes resulting from "scarfed" RCS nozzles such as were present on the Space Shuttle Orbiter and are currently present on the SpaceX Dragon spacecraft. Such plumes are three dimensional in nature and the dependence on ϕ is required. For assessing effects such as the interaction of the plume with a complex impingement target such as ISS and for assessing the firing of multiple RCS engines simultaneously, a high fidelity approach combining CFD and the direct simulation Monte Carlo (DSMC) method is employed. These high fidelity techniques have matured significantly since the Shuttle-Mir and during the ISS programs. Today, high fidelity modeling plays a more significant role than in previous decades when ground test and flight test were more of a necessity. The remainder of the paper will provide an overview of the methodology of these high fidelity techniques and illustrate how the current maturity of the associated tools and

computational capabilities is enabling assessments of increased complexity and at increased frequency. In addition to providing continuing improvements to the engineering methods, this capability is also providing benefits to the ISS Program in terms of improved performance and decreased risk.

METHODOLOGY

The NASA-JSC approach to completely model with high fidelity techniques the impingement of on-orbit plumes on satellites is to separate the problem into two pieces. The first piece is the flow in the nozzle and downstream of the nozzle before there is any effect to the plume from the impingement target. CFD, approximate numerical solutions of the Navier-Stokes equations with thermo-chemical non-equilibrium, is used to simulate this “upstream” portion of the flow. As mentioned above, these CFD solutions are often used to develop the source flow models used in engineering assessments of plume impingement. Since the Navier-Stokes equations are derived using the continuum assumption, only the portion of the CFD simulation where this assumption is valid can be considered accurate. The second piece of the flow is the “downstream” portion of the flow, and the direct simulation Monte Carlo (DSMC) method is employed. DSMC differs from traditional CFD in that the flow is represented as a large number of simulated molecules rather than a numerical solution to the continuum based Navier-Stokes equations. Collisions between simulated molecules are treated with a Monte Carlo technique based upon probabilities derived from the kinetic theory of gases. These collisions are decoupled from molecular motion, distinguishing DSMC from the Molecular Dynamics technique. DSMC is applicable to flows ranging from free molecular to continuum; however, the computational cost increases as the mean free path decreases in size relative to length scales characterizing the flow to be simulated. The decomposition of the simulation into two pieces is illustrated in figure 1.

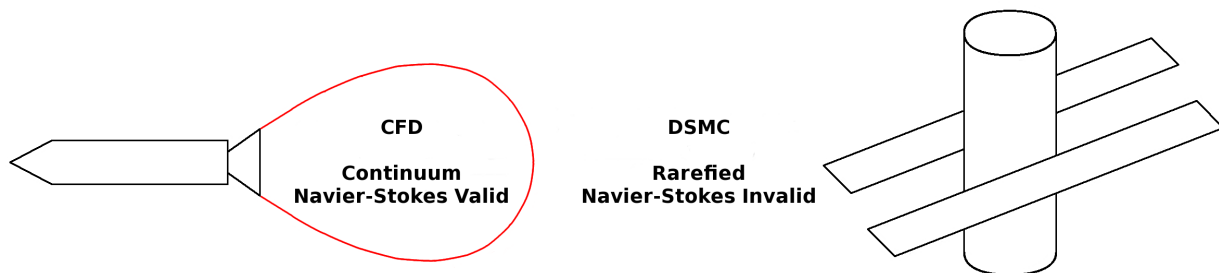

Fig. 1. Illustration of the separation of a high fidelity plume impingement simulation into “upstream” and “downstream” pieces. CFD is used upstream where the continuum assumption holds and the Navier-Stokes equations are valid whereas DSMC is used downstream where the flow becomes rarefied and the Navier-Stokes equations may no longer accurately model flow physics.

As the density increases, the mean free path decreases. The cost of DSMC therefore increases with the applicability of the continuum assumption. A strategy to optimize simulation performance is to split the simulation at the point where the continuum assumption is assumed to fail. The parameter introduced by Bird, which increases with rarefaction, is often used to determine the location of this surface.¹ Typical values of this parameter range from 0.03 to 0.05. In practice however this may not be possible as the disturbance to the free plume from the impingement target may extend into this continuum portion of the flow. Also, when simulating more than one RCS engine, one may wish, in order to simplify the interface between the CFD and DSMC regions, to place all plume-to-plume interactions in the DSMC piece. The CFD/DSMC interface is therefore often located where the parameter of Bird is significantly less than the cited values.² Under such scenarios, the size of DSMC portion of the simulation must be increased at the cost of computational performance in order to achieve the desired accuracy or simulation simplicity. Since it is not often clear a priori where to place the CFD/DSMC interface, experience and a process of trial-and-error then become important.

Two CFD codes have been used over the years for the upstream simulation: the commercially available General Aerodynamic Simulation Program (GASP) code and the NASA developed Data Parallel Line Relaxation (DPLR) code.³⁻⁴ Both of these codes employ the finite volume approach and include finite rate thermo-chemical non-equilibrium. Both codes were developed to be applied to hypersonic re-entry

problems, but have been applied to many other applications including vacuum plumes. The Chemical Equilibrium with Applications (CEA) code is used to estimate the proper chamber conditions to apply as a boundary condition for the inlet for both CFD solvers.⁵ Specifically the user supplies the propellants, chamber pressure, and, in the case of bipropellant engines, the oxidizer to fuel ratio to CEA. CEA will then compute the chamber temperature, density, and species mole fractions. The thrust and mass flow rate, along with the nozzle contour, for a given thruster are provided by the engine manufacturer, and the mass flow rate together with the computed chamber density and nozzle inlet area are used to compute the gas velocity at the inlet. The exit boundary condition can be problematic. Both codes support an extrapolation boundary condition appropriate for supersonic flow at the exit; however, this boundary condition can cause issues during the relaxation from the assumed initial condition. In the case of GASP, the approach typically taken was to initialize the flow domain with chamber conditions and to then prescribe a low pressure at the exit. Once the solution had progressed such that supersonic flow was well established from the nozzle throat out into the plume, the boundary condition would be changed from the low exit pressure to supersonic extrapolation. The timing of this change is important as if done either too early or too late, the plume would not relax to the desired steady state condition with supersonic flow over the entire exit. In the case of DPLR, the code does not have the ability to change the boundary condition during the run. Therefore, the solution domain is initialized with a density several orders of magnitude lower than at the inlet and with a large supersonic velocity so that the extrapolation boundary condition may be used continuously during relaxation of the solution from the initial to the steady state. In some cases different initial conditions in the nozzle and plume were required to achieve the desired result, particularly if simulating a large plume where the flow is very rarefied at the exit. Grid sequencing is a provided feature for both solvers and facilitates achieving the desired results. Low temperatures in the plume cause issues with GASP as these temperatures are below the valid range for the curve fits used for the chemical rate terms and for the transport properties such as viscosity. Chemical reactions and viscous terms are therefore disabled in the plume portion of the flow domain to achieve reasonable results with GASP. Disabling these terms in the plume is however not considered an issue. First, at these locations in the plume the chemistry is essentially frozen with almost no chemical reactions occurring. Second, the physics in the plume is dominated by convection, and the diffusion of mass, momentum and energy as modeled with the transport terms have only a minor effect in the plume. Furthermore, rarefaction is becoming important in much of the plume region and the modeling of viscous effects and heat conductivity effects in the Navier-Stokes equations is beginning to break down. So, any small error from disabling transport phenomena in this region is irrelevant, as this portion of the CFD solution will be discarded and replaced by results from the DSMC simulation. For DPLR, disabling the chemistry and viscous terms is not necessary as the equations for reaction rates and transport properties have low temperature limiters thereby simplifying the procedure to achieve the desired result when using DPLR.

For the downstream portion of the flow, the DSMC Analysis Code (DAC) developed by NASA was employed.⁶⁻⁷ DAC is a general purpose DSMC code which is being used by a number of NASA centers, DoD facilities, U.S. aerospace companies, and U.S. universities. DAC has a number of features allowing for the efficient DSMC simulation of complex problems. DAC was designed to support complex geometries and boundary conditions, to cope with large variations in density, to effectively utilize parallel computing capability, to be portable to a large number of computer architectures, and to use automation extensively to relieve the user of time consuming tasks. Many key features of DAC that were developed to meet these design goals are given in the remainder of this section.

DAC uses an unstructured triangular grid to represent surface geometry and other computational boundaries, (such as a plume inflow boundary). The use of unstructured triangles allows for arbitrarily complex geometries to be modeled; however, the user must prepare these surfaces resulting in the most labor intensive step in performing a DAC simulation. Modern grid generation tools however ease the creation of such surface meshes, and such a grid generation tool used by NASA-JSC for DAC simulations is the GRIDGEN code developed by Pointwise, Inc.⁸

While many DSMC codes require the user to perform the often labor intensive step of preparing the volume mesh, DAC automates this time consuming step using a two-level Cartesian network that is able to handle flows with large variations in density. The pre-processor included in the DAC software suite automatically creates the volume mesh with the following steps. The user defines the boundaries and the

number of divisions in each Cartesian direction for a rectangular parallelepiped computational domain surrounding the surface mesh. The pre-processor uses this input to divide the computational volume into constant size Level-I Cartesian elements. Then, one or more Level-II Cartesian elements are formed within each Level-I volume. DSMC computational cells then are created from Level-II volumes taking into account the possible clipping of the volumes by the triangular surface elements. Level-II volumes may be split into more than one computational cell in the case of thin surfaces completely dividing a Level-II volume into two or more non-contiguous regions. An example would be a thin solar array slicing a Level-II volume into two unconnected regions. Recent enhancements have been made to DAC to improve the robustness of the “volume clipping” routines.⁹ Level-II volumes are intended to achieve mean free path resolution locally. The ratio of simulated molecules to real molecules and the computational time step may vary from one Level-I volume to another to improve the simulation accuracy and efficiency. This topology for the DSMC computational cell network enables the simulation of extremely complex flows.

The procedure to use the rich set of meshing capabilities described above is as follows. For an initial solution, the pre-processing software assumes inflow boundary conditions everywhere and creates a volume and cell network appropriate for this assumption – essentially a uniform network of cells with uniform global values for the time step and the ratio of real to simulated molecules. The pre-processing software then is able to use the initial solution to create a more appropriate volume and cell network using a solution adaptive technique, and the solution adaptation process may be repeated as required. With default settings for an adaptation, the pre-processor will create a cell network with mean free path resolution throughout the computational domain by dividing the Level-I volumes into multiple Level-II volumes where required. The pre-processor will also use information from the previous solution to set the local time step and ratio of real to simulated molecules for each Level-I volume in order to maintain time steps below the mean time between collisions and to maintain the number of simulated molecules in a cell near a computationally optimum value of 10. The user however may alter the default settings and therefore has fine control over the adaptation process. For example, a target cell size larger or smaller than a mean free path can be requested. Also, the maximum and minimum number of Level-II volumes per Level-I volume can be specified thereby limiting the smallest or largest size for a Level-II volume. These controls are specified independently for regions near surfaces and away from surfaces. The distance that defines the region “near” surface may also be controlled. A typical DAC grid is shown in figure 2 illustrating how, on the windward side of this lifting body, the Level-I volumes are divided into multiple Level-II volumes to achieve mean free path resolution where the flow density is large.

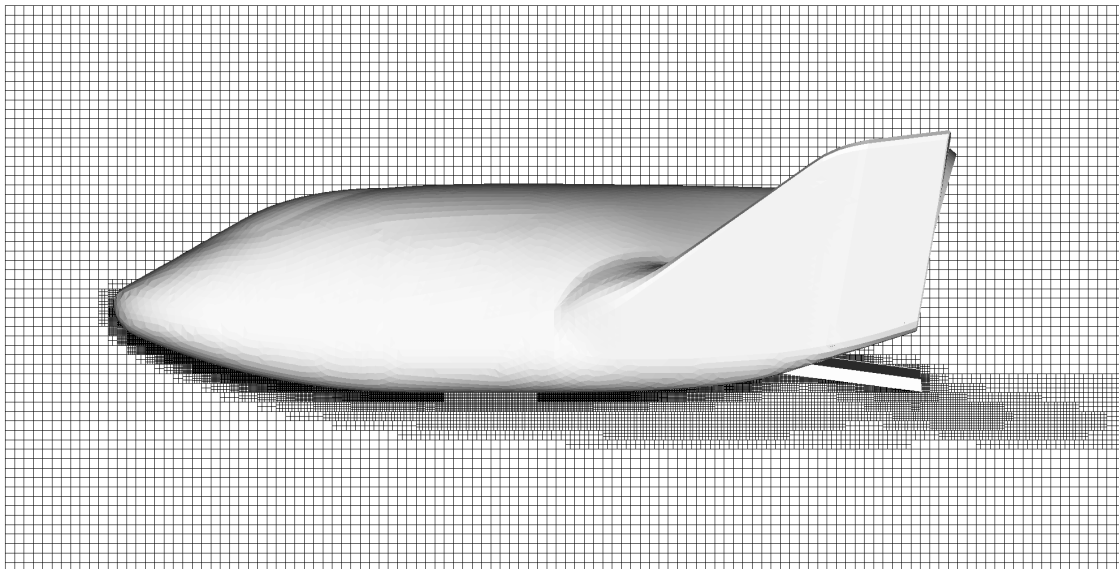

Fig. 2. Typical DAC volume and cell network for a re-entry vehicle.

While being a general purpose DSMC code, DAC was developed with the intent of being an easy to use and efficient code for the simulation of on-orbit plumes. DAC was designed to allow any triangulated surface to be an inflow boundary for the DSMC simulation. It is therefore possible to create a triangulated surface with a grid generation tool and use a CFD plume solution to determine the appropriate inflow molecular flux at that boundary. The required parameters at the inflow boundary are the local values of number density, the components of the velocity vector and the total temperature. With this information DAC is able to sample from the appropriate Maxwellian distribution to obtain the proper incoming distribution of simulated molecules. This capability in DAC enables the two “piece” approach illustrated in figure 1. Only a few other DSMC codes offer this feature. Figure 3 shows such a plume inflow surface.

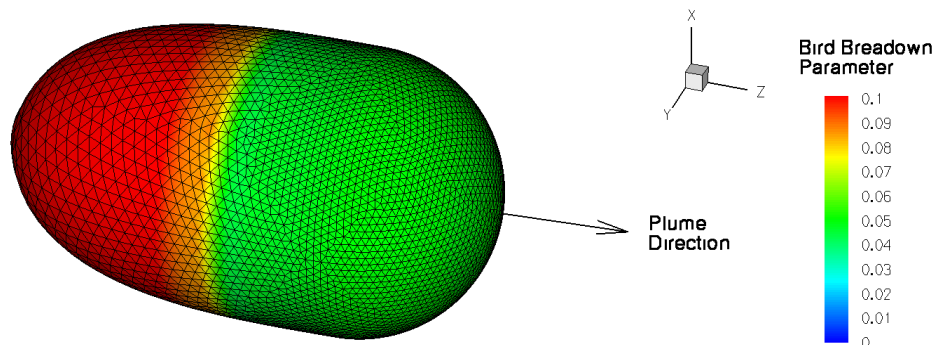

Fig. 3. Example of plume inflow boundary appropriate for use in DAC.

DAC has additional features that facilitate the simulation of complex flows. Domain decomposition is employed to create parallel versions of both the pre-processor and the simulation codes. Specifically, the Message Passing Interface (MPI) software library is used to allow multiple threads across distributed memory systems to each work on a small portion of the domain and use messages to communicate information between the threads when necessary.¹⁰ This allows very large simulations to be performed, and the current limit on problem size is just over two billion molecules although software updates are planned to extend this limit. The data files are designed to be independent of the number of software threads employed. This allows a user, for example, to stop a simulation and then resume on a larger or smaller number of threads if desired without having to perform any manipulation on the data files. During a run, DAC monitors parallel performance and dynamically alters the distribution of computational cells assigned to each thread as needed to balance the computational load among the threads. The use of Cray style pointers enables dynamic memory allocation, and pre-processor directives enable the portability of the source code to several architectures.

Finally, DAC has advanced options for the selection of candidate molecules for collision that improve performance. In DSMC, to simulate the correct physics, the molecules in a collision candidate pair should be close to one another – within a mean free path. Since, in traditional DSMC, both candidates for a collision are selected at random from the population inside the cell, the sides of computational cells should be about a mean free path in length. Much larger cells allow for molecules separated by many mean free paths to collide thereby providing a non-physical mechanism for the transport of momentum and energy. Bird developed “sub-cells” for collision partner selection so that the mean free path restriction on cell size may be relaxed somewhat.¹¹ DAC on the other hand has an option to select the nearest neighbor in the cell as the second candidate molecule after the first candidate has been chosen at random. This method has been shown to provide similar benefits as compared to sub-cells without the additional programming difficulty.¹²⁻¹³ The search for the nearest neighbor is not cost prohibitive since the adaptation process targets the ratio of simulated to real molecules such that 10 simulated molecules per cell is typical and cells with very large numbers of molecules are rare. There are other options in DAC to search for the nearest neighbor in certain directions such as perpendicular to directions with large gradients in macroscopic parameters such as may be found in a boundary layer.

RESULTS

This section presents selected examples of simulations of plumes and plume impingement performed recently. Figure 4 presents a dual jet plume simulation for the SpaceX Dragon spacecraft that recently completed a successful cargo re-supply mission to the ISS. All of the reaction control system engines on Dragon are scarfed as the vehicle shape is driven somewhat by aerodynamics due to the spacecraft's capability to re-enter and return cargo from the ISS to Earth. The results shown in figure 4 are for the simultaneous firing of two scarfed (33.6°) roll jets. The figure shows the energy flux in the plume as obtained with DAC for a single cutting plane. The flow direction is essentially from bottom to top in the figure. A three dimensional CFD solution was obtained for each jet using DPLR and DSMC inflow boundaries were developed with these CFD solutions. The blue bulb shaped regions labeled D1T2 and D2T1 represent the CFD regions of the simulation. The interaction region is aligned nearly vertically between the two jets and is demarked by the two slender orange contours in the middle of the figure. Such simulations were used to create augmentation factors for use when superposing single jet source flow estimates developed for SpaceX Dragon RCS jets in engineering assessments of dual jet firings.

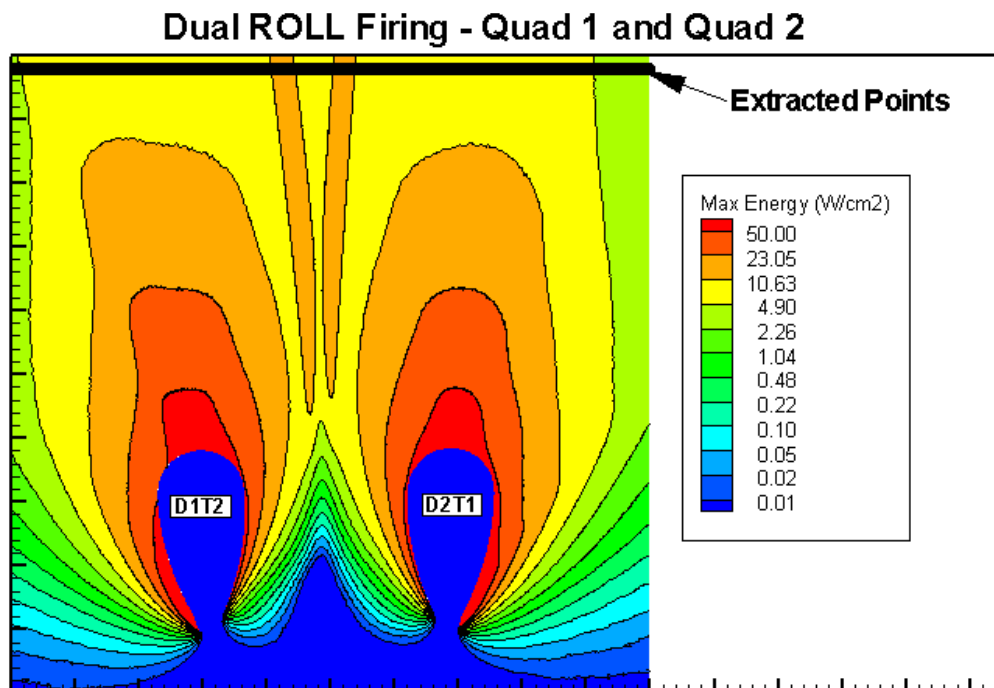

Fig. 4. Energy flux contours for a dual jet firing of SpaceX Dragon roll RCS thrusters.

Figure 5 shows the impingement of SpaceX thrusters on the Space Station Remote Manipulator System (SSRMS) Canadarm2 from a SpaceX Dragon RCS jet firing using the high fidelity CFD/DSMC approach. The SSRMS is used to grapple the Dragon during berthing and release operations and is therefore often one of the ISS components most affected by plume impingement from Dragon and other vehicles that berth to the ISS rather than dock. The figure gives a slice of flow density and heating rates to the end effector of the SSRMS. This particular case was one of the most stressing as predicted by engineering tools particularly for the small camera box indicated by the label “Extracted Points #1” in the figure. For this particular case, it was believed that the engineering tools should work well for the location on the end effector labeled “Extracted Points #3” but predict unreasonable high heating for the small camera box. The high fidelity assessment was performed to quantify the conservatism. The comparison of engineering results and high fidelity results are shown in the two plots given in figure 6. In both plots, three curves of heat flux values are given for a line of selected points along the exterior surface. In these plots, the curve labeled “Max Energy” corresponds to assuming all the local energy in the source flow plume model is transferred to the impingement target – essentially a modified Stanton number of 1 – which is known to have large conservatism unless the flow is near free molecular. The “bridging function” curve refers to a

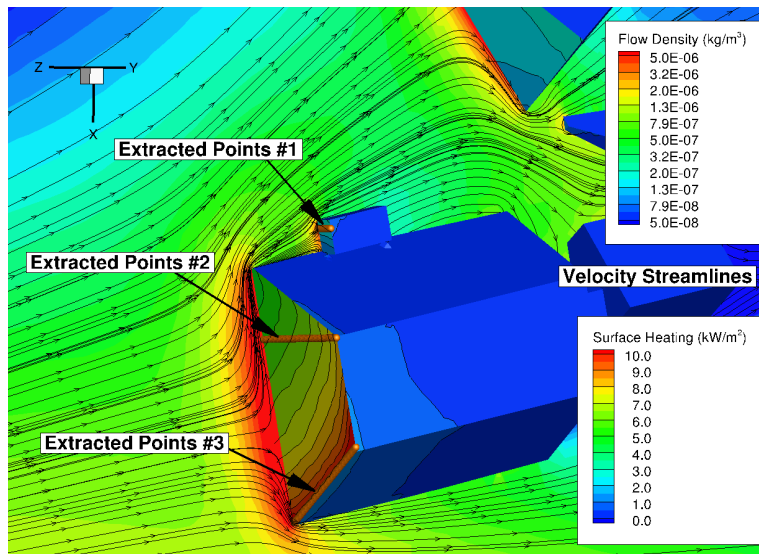

Fig. 5. Plume impingement from the SpaceX Dragon spacecraft to the end effector of the SSRMS Canadarm2.

more sophisticated engineering assessment that estimates the heat flux with an empirical relationship to bridge between continuum and free molecular correlations for the modified Stanton number. The third curve on the two plots labeled DSMC gives the high fidelity results. The plot on the left gives the results for the camera box (Extracted Points #1) and the plot on the right gives the results on the leading edge of the SSRMS end effector (Extracted Points #3). In the engineering assessment the camera box was treated as an independent component and, to ensure conservatism, any shading provided by the SSRMS end effector was not considered. From figure 6 it can be seen that the maximum energy approach is conservative. It can also be seen in the plot on the right that the bridging function approach compares extremely well with high fidelity results. This is not surprising as this is a situation where the engineering approach is expected to perform well. Finally, the amount of conservatism for the heating rate to the camera box (Extracted Points #1) as determined by the bridging function approach is about an order of magnitude. This is also not surprising as the end effector is providing significant shading of the camera box from the plume and this effect was not modeled in the engineering approach. These results validate the current strategy to use engineering methods to identify stressing cases and then to use high fidelity assessments on the small subset of cases where the engineering results identify potential concerns.

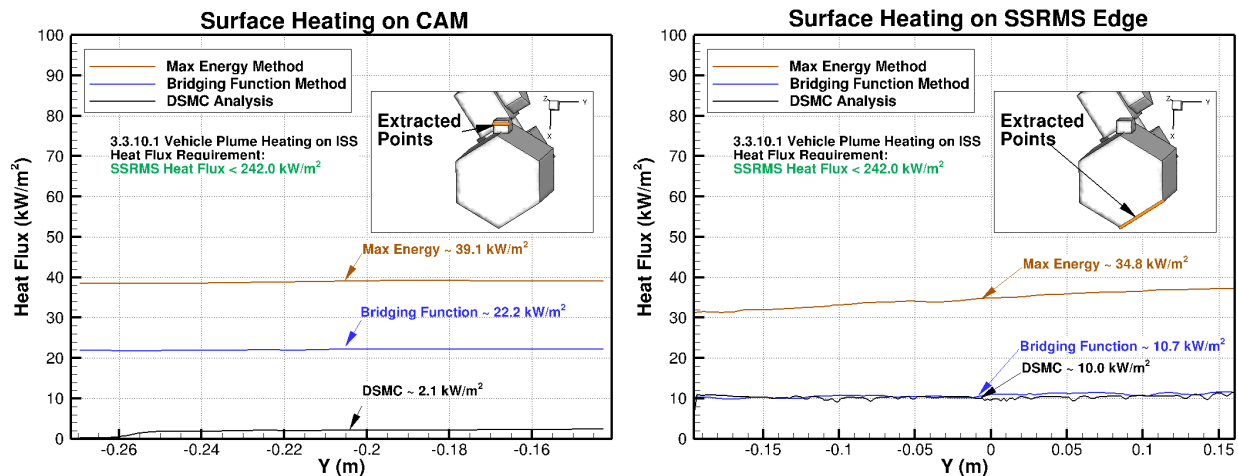

Fig. 6. Comparisons of high fidelity and engineering assessment of plume impingement heating from the SpaceX Dragon spacecraft to the end effector of the SSRMS Canadarm2.

Figure 7 shows the high fidelity results for a case identified as stressing from engineering assessment for impingement of the RCS jet (an Aerojet R-1E) from the Japan Aerospace Exploration Agency (JAXA) H-II Transfer Vehicle (HTV) to the JAXA Exploration Module (JEM) component of the ISS. This case is from a database of likely trajectories used to certify the proximity operation design does not result in excessive plume impingement effects. In other words, this case does not represent an actual flight event. Only DSMC results are shown as the CFD “piece” is represented by the small, red bulbous surface attached to the HTV. A cutting plane of number density contours is presented for the flow field and the heat flux is presented on the surface of the ISS. The peak heat flux to the JEM is significant at about 14 solar fluxes.

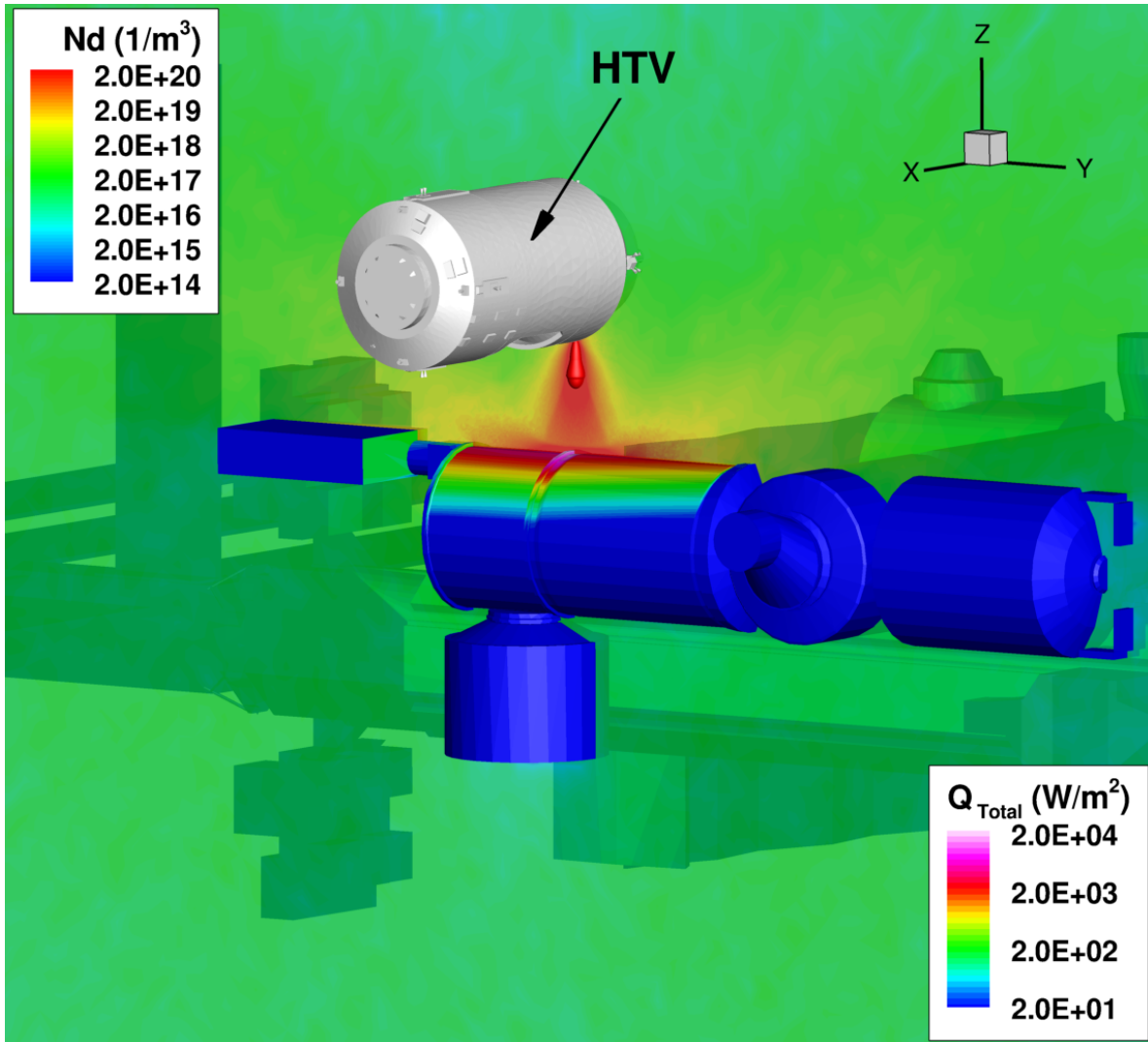

Fig. 7. High fidelity simulation with CFD and DSMC of plume impingement from the HTV to the ISS.

Finally, figure 8 shows the results for an actual flight event with the HTV that occurred on Sep. 12, 2012. This case was an abort case during the fly away of the third HTV mission from the ISS. A small, unplanned translation was imparted to the HTV during the release from the SSRMS. This precipitated an abort where the four main engines of the HTV fired for about 10 seconds. CFD results for the Aerojet R-4D engine have been used to set the inflow boundary condition for the DSMC simulation. Results for this engine configuration were presented in reference 2 for the plume alone without any plume impingement being simulated. The simulation is a close approximation to actual events as while the first two flights of HTV used the R-4D, a similar Japanese produced engine was used on the third flight of the HTV. The top half of figure 8 shows the four inflow boundaries for the main engine plumes with colored

contours of number density from four different viewing angles. The Soyuz 31S spacecraft was most affected by plume impingement from the abort. The high fidelity assessment of this event was performed to assess the readiness of the 31S vehicle to return to Earth. The bottom half of the figure shows the estimated heat flux to the Soyuz 31S with a peak value slightly in excess of one solar flux. While this is a fairly modest value, the length of the burn (10.625 seconds) resulted in a significant heat load. Assessments of the thermal response of the Soyuz solar array demonstrated that the event did not cause in excessive temperatures on the array, and the multi-national team investigating the event was able to clear any concern regarding the health of Soyuz 31S.

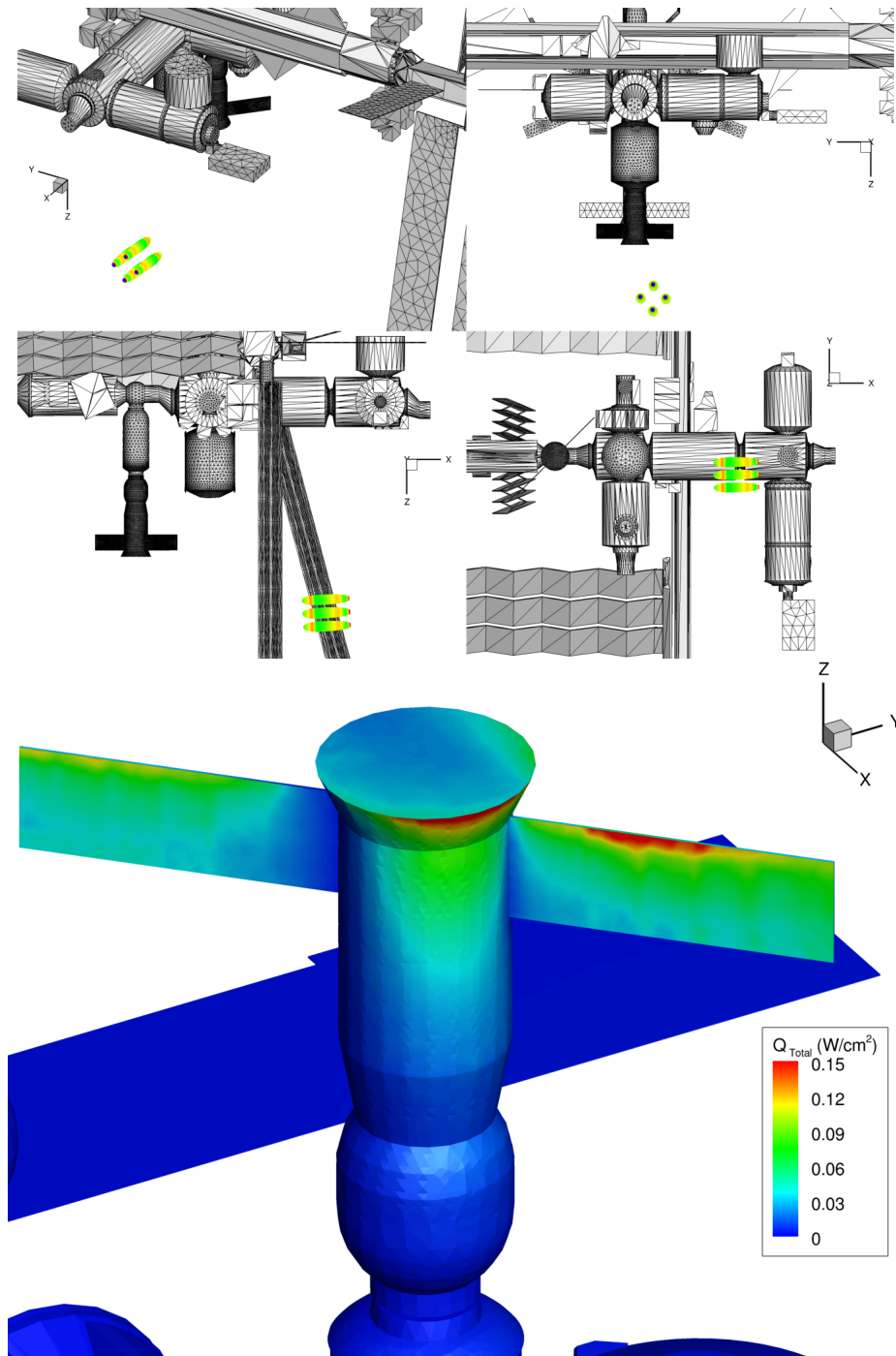

Fig. 8. High fidelity simulation with CFD and DSMC of plume impingement as occurred during the HTV abort on Sep. 12, 2012.

CONCLUDING REMARKS

The Applied Aerospace and CFD Branch at NASA-JSC continues to support the International Space Station Program by ensuring that the ISS is protected from adverse effects resulting from plume impingement. High fidelity modeling plays a key and growing part of this effort, and the approach combining CFD and DSMC developed to assess such effects continues to improve. Recent experience demonstrates that this capability provides important results that improve lower fidelity engineering tools and proves invaluable in assessing events such as the recent HTV main engine abort.

ACKNOWLEDGEMENTS

The authors greatly appreciate the contributions of Mr. Andrew Prisbell in performing the assessment of plume impingement from the SpaceX Dragon to the ISS SSRMS.

REFERENCES

1. Bird, G. A., *Breakdown of Continuum Flow in Free Jets and Rocket Plumes*, 12th International Symposium on Rarefied Gas Dynamics, *Progress in Aeronautics and Astronautics*, (1981).
2. Lumpkin, F. E., III, and Larin, M. E., *Simulation of the Plume from the Firing of Four R4D Engines on the H-2 Transfer Vehicle using the GASP and DAC Codes*, 29th JANNAF Exhaust Plume Technology Subcommittee Meeting, (2006).
3. Walters, R. W., Cinnella, P., and Slack D. C., *A Status Report on GASP - A General Aerodynamic Simulation Program*, 7th National Aerospace Plane Symposium, Paper No. 9, NASA Lewis Research Center, (1989).
4. Wright, M. J., Candler, G. V. and Bose, D., *Data-Parallel Line Relaxation Method for Navier-Stokes Equations*, *AIAA Journal*, **36**, 1603-1609, (1998).
5. McBride, B. J., and Gordon, S., *Computer Program for Calculation of Complex Chemical Equilibrium Compositions and Applications – II. Users Manual and Program Description*, NASA RP-1311, NASA Lewis Research Center, (June 1996).
6. LeBeau, G. J., *A parallel implementation of the direct simulation Monte Carlo method*, *Computer Methods in Applied Mechanics and Engineering*, **174**, 319-337, (1999).
7. LeBeau, G. J., and Lumpkin, F. E., III, *Application highlights of the DSMC Analysis Code (DAC) software for simulating rarefied flows*, *Computer Methods in Applied Mechanics and Engineering*, **191**, 595-609, (2001).
8. Chawner, J. R., Matus, R. J., and Steinbrenner, J. P., *Evolution of GRIDGEN's Data Hierarchy to Unstructured Grids*, 6th International Grid Conference, Greenwich, United Kingdom, (Jun. 6, 1998).
9. Zhang, C., and Schwartzenuber, T. E., *Robust cut-cell algorithms for DSMC implementations employing multi-level Cartesian grids*, *Computers & Fluids*, **69**, 122-135, (2012).
10. Message Passing Interface Forum, *MPI: A Message-Passing Interface Standard*, Computer Science Dept. Technical Report CS-94-230, *University of Tennessee* (1994).
11. Bird, G. A., *The G2/A3 Program System Users Manual*, G.A.B. Consulting Pty Ltd, Killara, N.S.W, Australia, (1992).
12. LeBeau, G. J., Boyles, K. A., and Lumpkin, F. E., III, *Virtual Sub-Cells for the Direct Simulation Monte Carlo Method*, AIAA Paper No. 2003-1031, 41st AIAA Aerospace Sciences Meeting and Exhibit, (Jan. 2003).
13. Boyles, K. A., LeBeau, G. J., Lumpkin, F. E., III, and Blanchard, R. C., *The Use of Virtual Sub-cells in DSMC Analysis of Orbiter Aerodynamics at High Altitudes Upon Re-entry*, AIAA Paper No. 2003-1030, 41st AIAA Aerospace Sciences Meeting and Exhibit, (Jan. 2003).



High Fidelity Simulations of Plume Impingement to the International Space Station

Forrest E. Lumpkin III, Ph.D., *NASA Johnson Space Center, Houston, TX*

Jeremiah J. Marichalar, *Jacobs Technology – ESCG, Houston, TX*

Benedicte D. Stewart, Ph.D., *MTS Inc., Houston, TX*

Presentation to the
33rd JANNAF Exhaust Plume and Signatures Subcommittee Meeting
Dec. 4, 2012

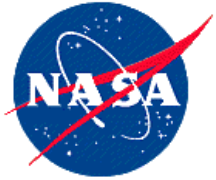

Outline



- Introduction
 - International Space Station (ISS) Proximity Operations.
 - Background: Engineering Methods for Plume Impingement.
- Methodology
 - Overview.
 - Computational Fluid Dynamics (CFD) Region.
 - Direct Simulation Monte Carlo (DSMC) Region.
 - CFD/DSMC Interface.
- Selected Results
 - SpaceX Dragon Dual Roll Jet Plume.
 - SpaceX Dragon Plume Impingement to Canadarm2.
 - Japan Aerospace Exploration Agency (JAXA) H-II Transfer Vehicle (HTV) Plume Impingement to ISS.
 - JAXA HTV Main Engine Abort Event of Sep. 12, 2012.
- Concluding Remarks



Introduction



- The International Space Station (ISS) is largest and most complex spacecraft ever built.
 - Assembled from components delivered on multiple launches.
 - Resupplied multiple times per year by a variety of spacecraft.
- Proximity operations (rendezvous, docking, berthing, separation) a key part of the ISS design and concept of operations.
 - Variety of spacecraft have, do, or will operate in close proximity to ISS.
 - Shuttle Orbiter, Soyuz, Progress, European Space Agency (ESA) Autonomous Transfer Vehicle (ATV), Japan Aerospace Exploration Agency (JAXA) H-II Transfer Vehicle (HTV), SpaceX Dragon, Orbital Sciences Cygnus, to-be-determined commercial crew spacecraft, and possibly NASA Orion.
 - These spacecraft are often termed “visiting vehicles”.
 - Many of these “visiting vehicles” did not exist when ISS was designed.
- Protecting the ISS from any adverse affects due to plume impingement is an important component of the planning and performance of proximity operations
 - Places constraints on Reaction Control System (RCS) thruster firings
 - Thruster location and orientation at firing, firing duration, firing frequency



Introduction: Proximity Operation Illustration

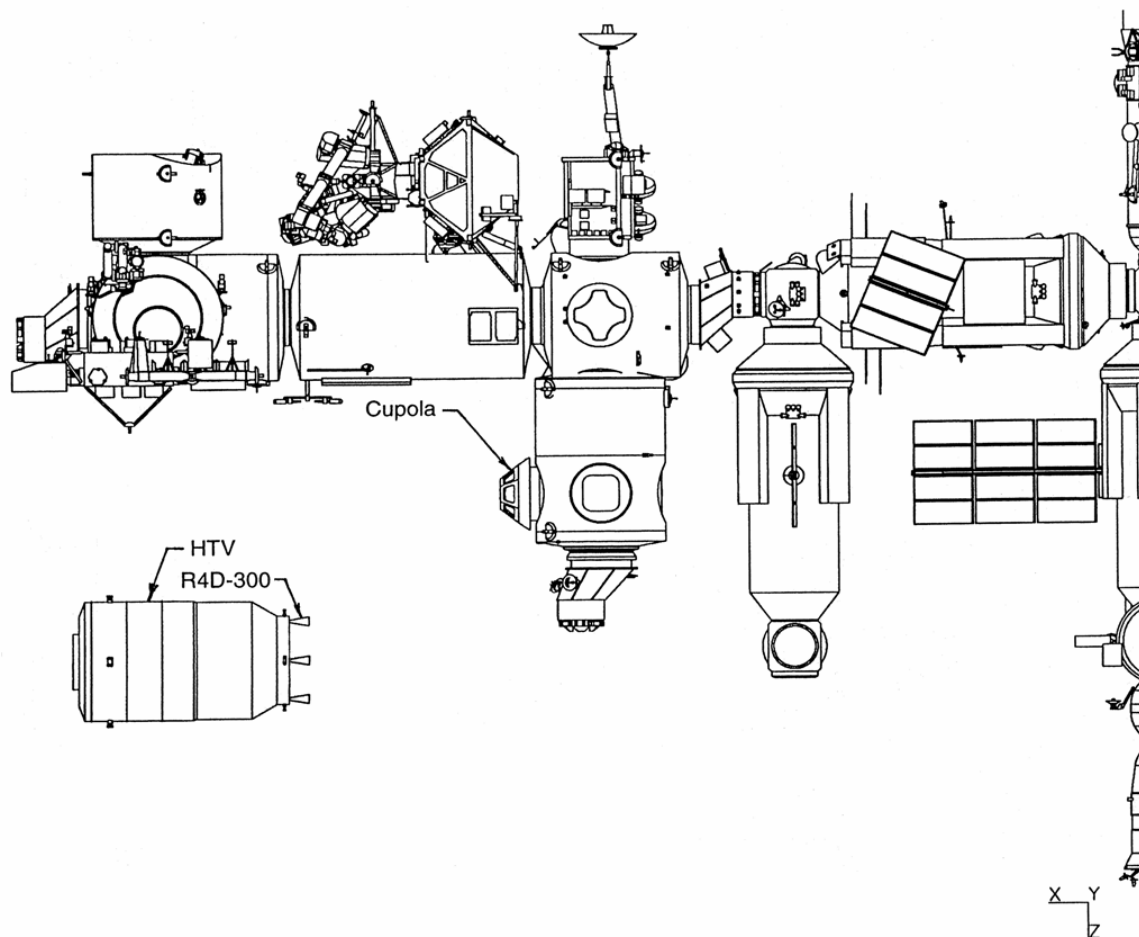



Assessing Plume Impingement



- For each vehicle, a database of proximity operations trajectories is developed.
 - Typically hundreds to thousands of trajectories to cover all possible scenarios
 - Variations in mass properties, mission phase (approach vs. separation), failures, etc.
 - Each trajectory may contain hundreds to thousands of thruster firings.
- Simple engineering methods are needed to assess a complete database whereas high fidelity modeling plays an important supporting role.
 - High fidelity modeling too expensive for assessment of a complete database.
 - High fidelity modeling used to develop and validate engineering models.
 - High fidelity modeling used for special cases (e.g. anomalies).
 - Separate engineering models for plume environment (e.g. source flow model) and plume impingement (e.g. modified Newtonian).

Plume Modeling

$$\rho = \rho(r, \theta) = f(r)g(\theta) = \frac{g(\theta)}{r^2}; \quad u = u_{\text{lim}} = \sqrt{2\gamma T / (\gamma - 1)}$$
$$P = c_p q = (c_{p0} \sin^2 \alpha) (\frac{1}{2} \rho u^2)$$

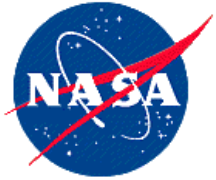

High Fidelity Modeling Methodology



- The complete on-orbit plume impingement problem has a density flow field which spans several orders of magnitude
 - Several atmospheres in the thruster combustion chamber to ~ 0.001 torr in the plume.
 - Navier-Stokes based computational fluid dynamics (CFD) not globally valid.
 - Direct Simulation Monte Carlo (DSMC) cost prohibitive at highest densities
- NASA-JSC method is to apply both CFD and DSMC to the problem
 - CFD in the “upstream” portion where Navier-Stokes equations are valid
 - DSMC in the “downstream”/impingement portion where cost is feasible
 - This decoupling works of the flow is supersonic at the interface

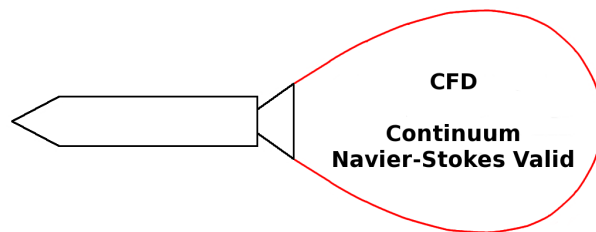

DSMC
Rarefied
Navier-Stokes Invalid

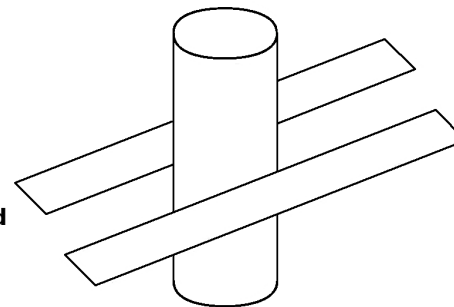



CFD Simulation



- Simulations have been performed for axi-symmetric jets, scarfed jets, axi-symmetric dual jets, and scarfed dual jets.
- Early simulations used the GASP commercial CFD code from Aerosoft.
 - Chemical reactions and viscous terms disabled in the plume due to low temperatures.
- Data Parallel Line Relaxation (DPLR) from NASA-Ames used now.
- Chemical Equilibrium and Application code of NASA-Glenn used to compute conditions in the combustion chamber.
 - Input: Propellants, chamber pressure. Output: density, temperature, mole fractions.
- GRIDGEN software from Pointwise used to generate structured finite volume grids
- Application of supersonic exit boundary condition requires care
 - In GASP must switch from low pressure BC to extrapolation BC during run.
 - In DPLR extrapolation BC used from initial state but a prescribed initial state required.
 - Without this treatment both codes will allow flow to enter at the exit boundary
- CFD results used in developing engineering source flow plume models.
 - For example in determining $g(\theta)$



Example CFD Result: R-4D-300

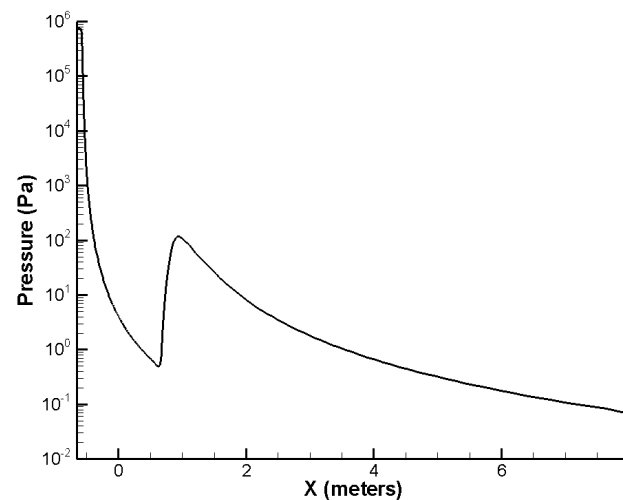
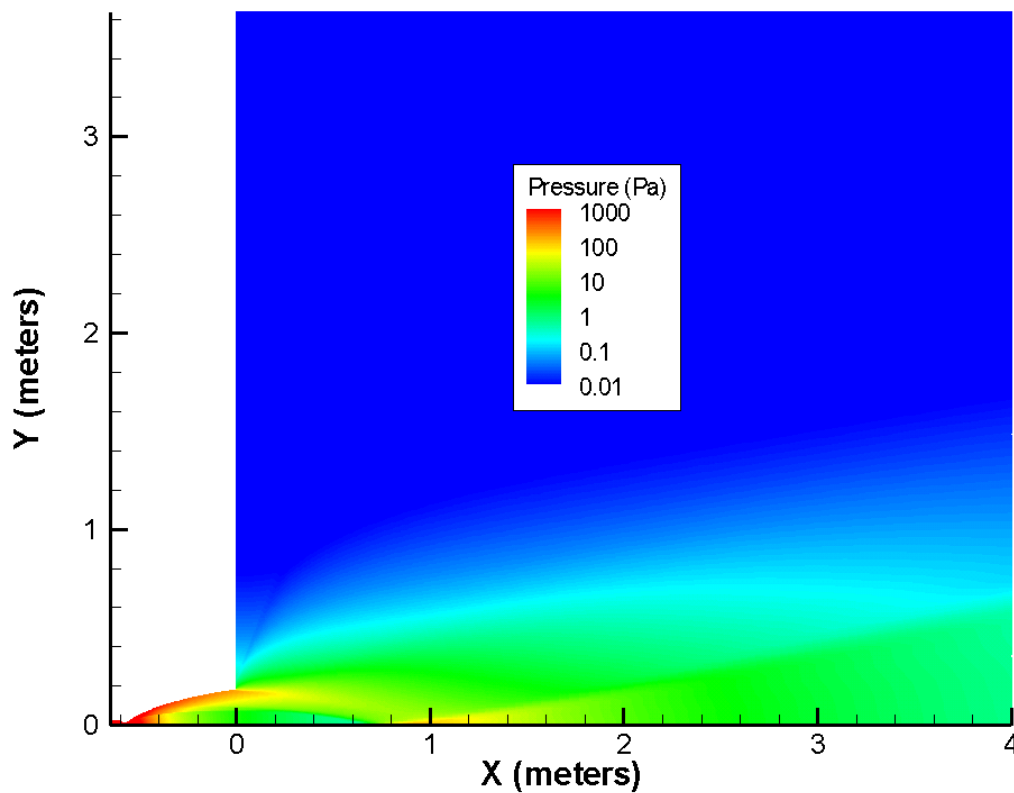

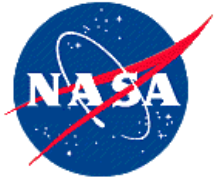

DSMC Simulation



- DSMC simulations employ the DSMC Analysis Code (DAC)
 - Developed at NASA-JSC.
 - Co-winner in 2002 of NASA Software of the Year.
 - Widely used with U.S. Government, Industry, and academia.
 - Design as a general purpose DSMC code with the following goals:
 - Support for complex geometries and boundary conditions
 - Ability to simulate flows with large variations in density
 - Automated volume meshing for ease of use and to satisfy DSMC simulation guidelines
 - Effectively use parallel computational problems to enable the simulation of large and complex problems.
 - Portability
- Key DAC features
 - Surfaces including complex boundaries represented with unstructured triangular meshes.
 - Two level Cartesian mesh for flow volume.
 - CFD/DSMC plume capability enabled with surfaces which can serve as an in flow boundary with non-uniform conditions.

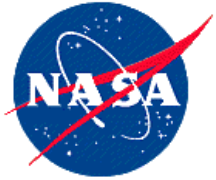

DSMC Analysis Code (DAC) Meshing Implementation



- A 2-level Cartesian grid system, completely uncoupled from the surface representation, is automatically generated by the software.
 - Relieves the user of this traditionally time consuming task, and insures that the fundamental constraints that govern the accuracy of the simulation are satisfied.
 - Cells are used to group neighboring molecules and also act as flow field sampling zones.

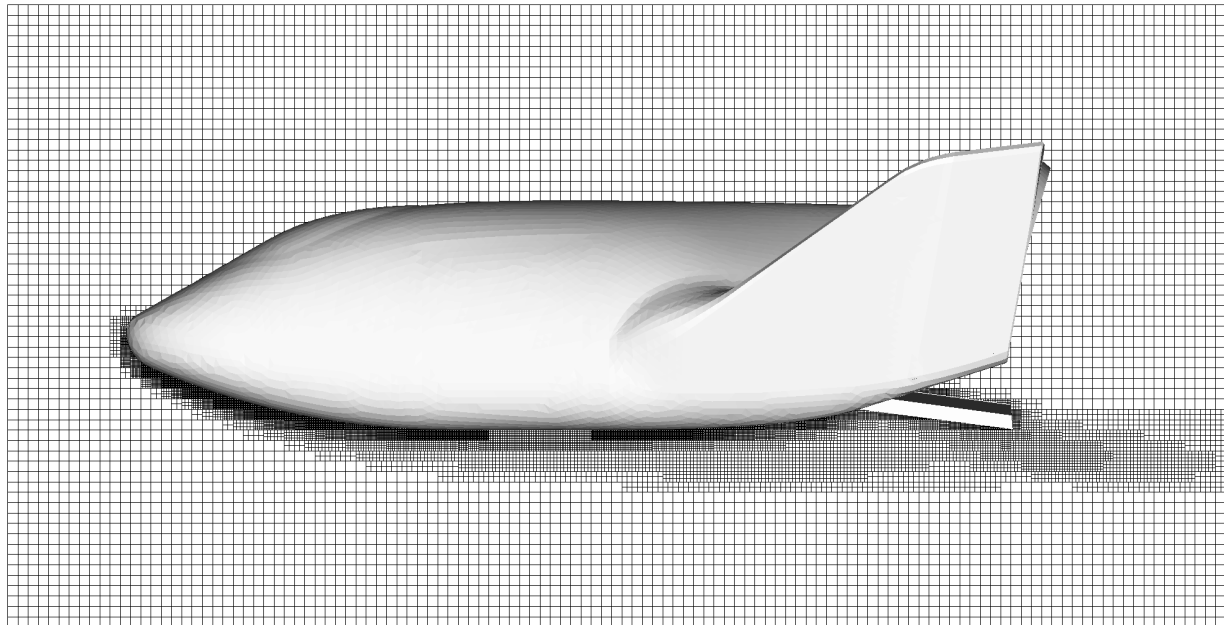



CFD/DSMC Interface for Plumes



- User may specify surface type in DAC.
 - Solid wall and non-uniform in flow boundary most commonly used types.
- Non-uniform in flow boundary used for the CFD/DSMC interface.
 - Each node on the surface stores the density, temperature, and velocity components interpolated from the CFD solution.
 - For each triangle, at each time step, simulated molecules are introduced based upon sampling from the appropriate Maxwellian distribution.

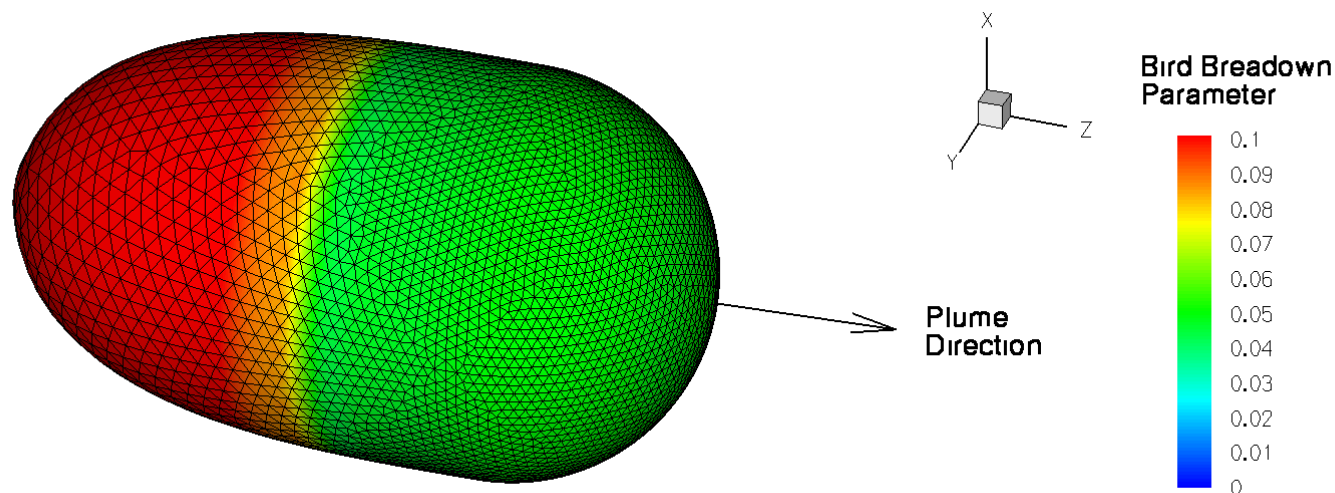



Example Results



SpaceX Dragon Dual Roll Jet Plume



- SpaceX Dragon roll jets have a moderate 33.6° scarf angle.
- DPLR used to compute a three dimensional CFD solution for a single roll jet
- DAC used to simulate the “downstream” plume including the dual jet interaction.
 - Results used in developing a dual jet augmentation factor of engineering assessments of plume heating to ISS.

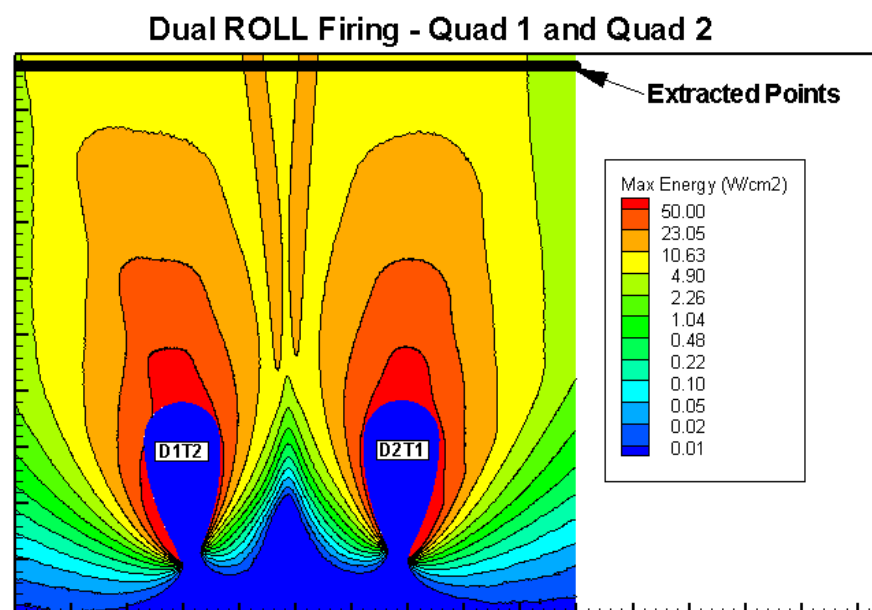



SpaceX Dragon Plume Impingement to Space Station Remote Manipulator System



- The Space Station Remote Manipulator System (SSRMS) Canadarm2 is used to berth the SpaceX Dragon to and from the ISS.
 - Canadarm2 therefore can experience high plume heating rates.
 - High Fidelity Simulation performed to assess performance of engineering methods.

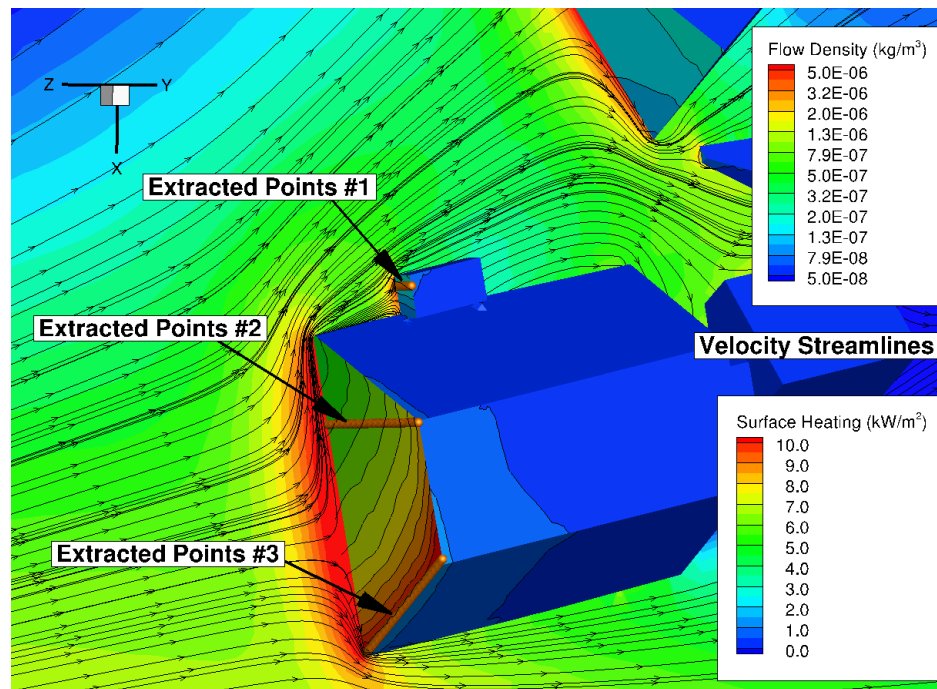



Comparison of High Fidelity and Engineering Methods for SpaceX Impingement to SSRMS



- Maximum energy method conservative by a comfortable margin as expected.
- Bridging function method perform very well for SSRMS leading edge
- Bridging function is conservative for the “camera box” (extracted points #1) due to shadowing from the SSRMS end effector
 - Shadowing not used in these engineering assessments since a line of sight approximation would not be conservative due to the flow not being free molecular.
 - DSMC automatically accounts for protection provided by the end effector.

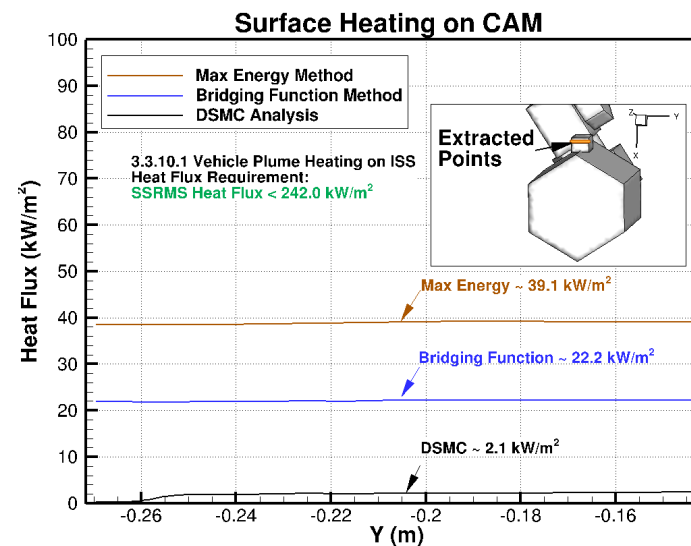
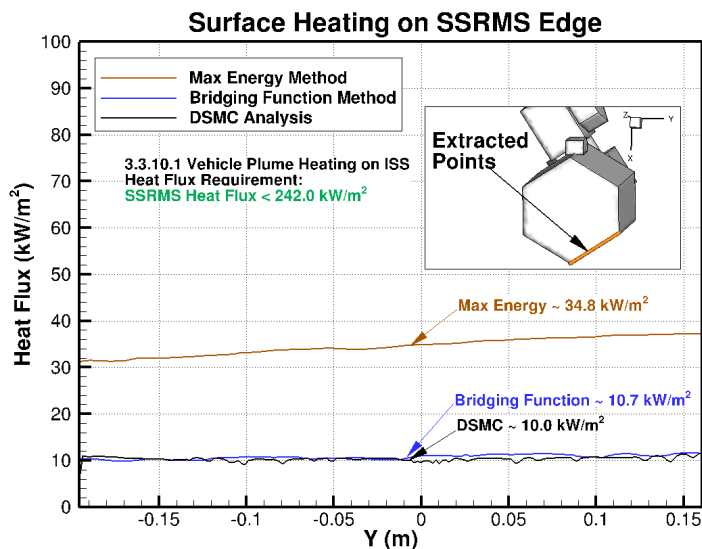



Impingement from HTV on to ISS



- A high fidelity simulation for a high heating case from the database of the impingement heating from HTV RCS thruster to ISS was performed.
 - High fidelity results show a heating equivalent to approximately 14 solar fluxes.

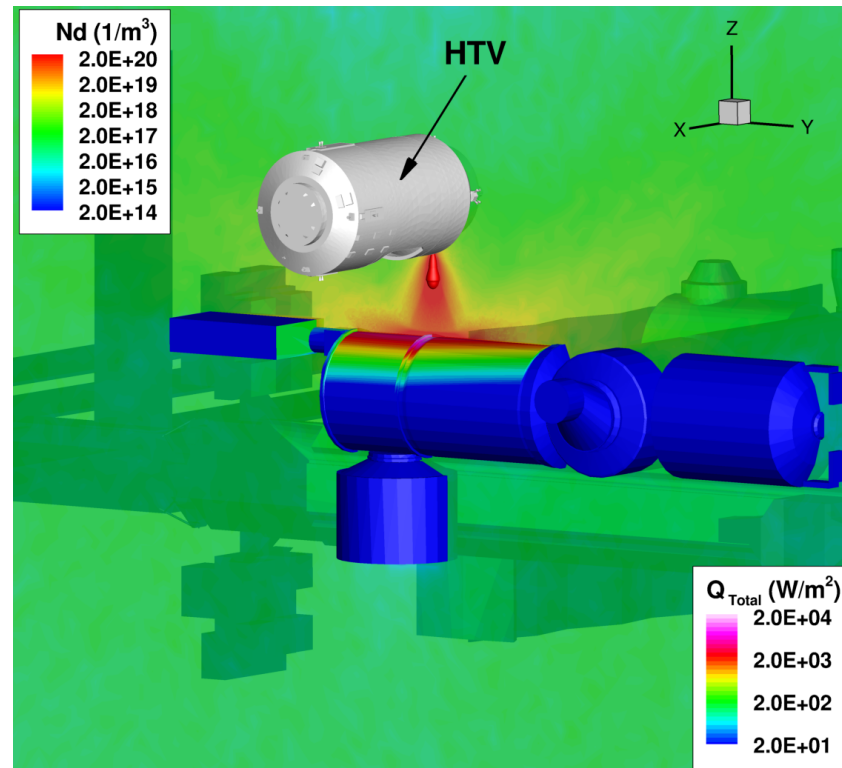



Main Engine Abort Event on Sep. 12, 2012



- On Sep. 12, 2012 due to an unplanned impulse being applied to the third HTV mission during departure, a main engine collision avoidance maneuver (CAM) was performed.
 - The four main engines fired for 10.625 seconds.
 - The Soyuz 31S vehicle experienced the most significant plume impingement during the event.
 - A high fidelity assessment was performed to assess the plume heating to the Soyuz 31S.
 - Main engines modeled with the R-4D-300 used on HTV1 and HTV2.
 - CFD for new Japanese main engine on HTV3 not available.
 - Use of R-4D considered appropriate as the two engines have very similar performance.
 - The heating rates to the Soyuz were provided to the Energiya specialists in Russia who certified the vehicle for re-entry.
 - Soyuz 31S returned safely with her 3 member international crew on Nov. 18-19, 2012.



Main Engine Abort Event on Sep. 12, 2012

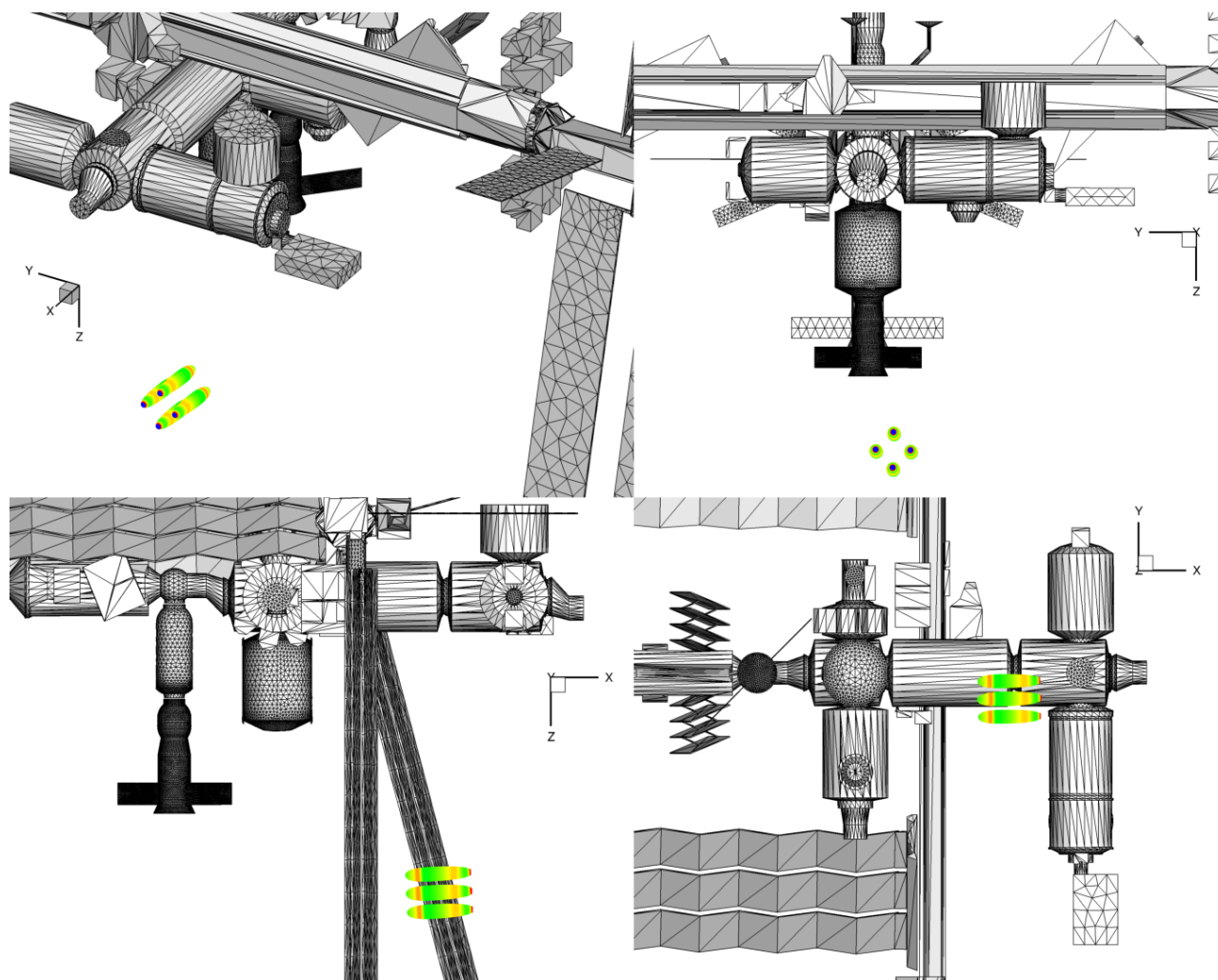

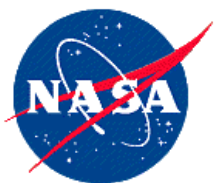

Main Engine Abort Event on Sep. 12, 2012

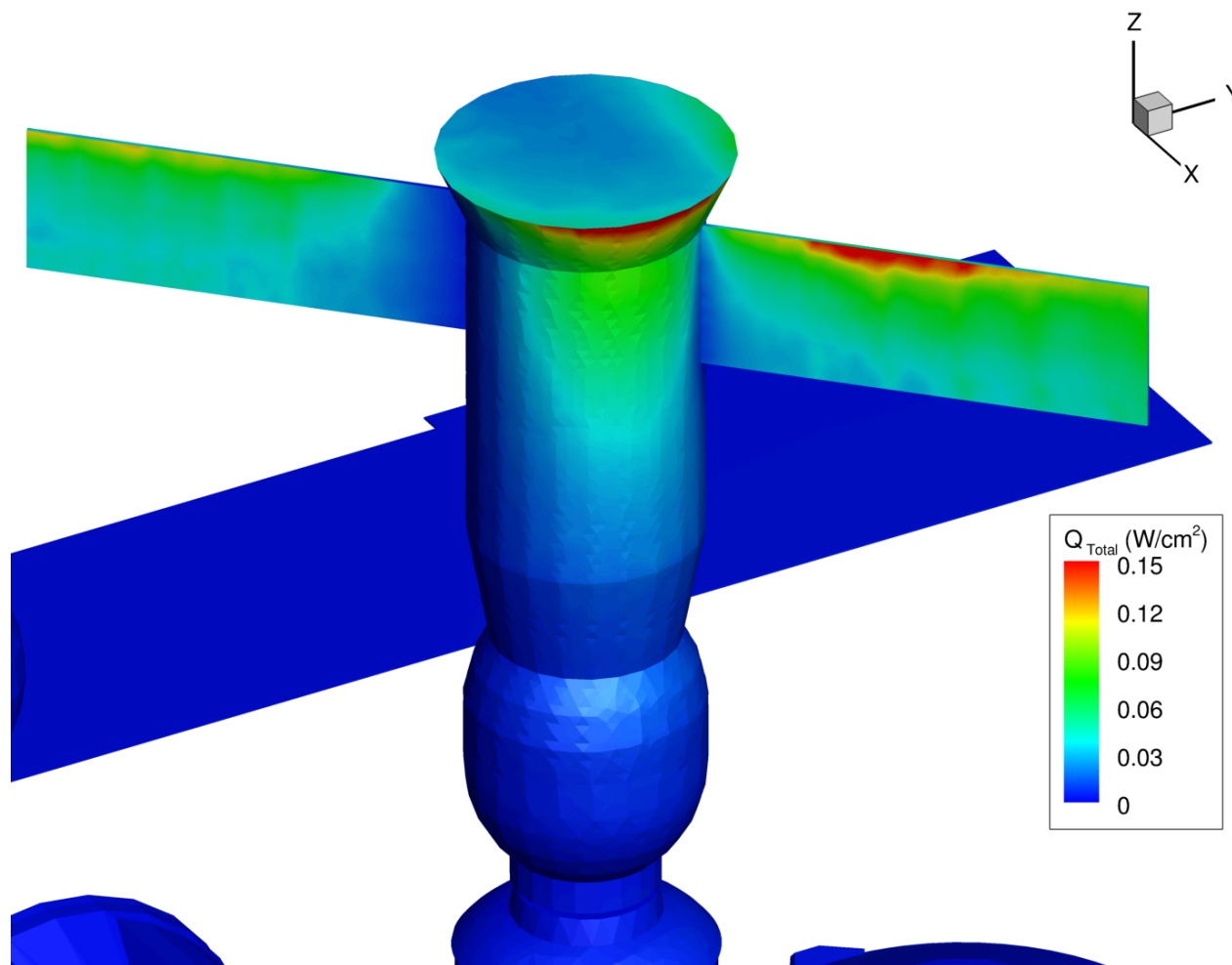



Concluding Remarks



- High fidelity modeling of plume impingement to the ISS plays a key roll in protecting the ISS from adverse effects.
 - High fidelity modeling used to develop and validate engineering models.
 - High fidelity modeling used for special cases where engineering models are known to be in error.
 - Conservative approaches and/or large safety factors are typically applied and high fidelity modeling can be used to “buy” back some of the margin if needed.
 - Such a conservative approach would be to not include line of sight shadowing such as for the example shown of the camera box on the SSRMS being impinged by Dragon.
 - High fidelity modeling is an important tool when investigating anomalies such as the HTV3 main engine abort of Sep. 12, 2012.
 - High fidelity modeling capability benefits the ISS program with improved performance and decreased risk.
- NASA-JSC continues to improve the high fidelity methodology
 - Suggesting improvements to CFD developers
 - DAC enhancements in work including
 - Increased problem size (number of simulated molecules).
 - Improved thermo-chemical modeling.
 - Investigation of improved meshing schemes (three Cartesian levels)