

National Aeronautics and Space Administration



## SCAN Testbed, Overview and Opportunity for Experiments

Richard Reinhart  
SCAN Testbed Principal Investigator

Sandra Johnson, Deputy Principal Investigator  
NASA Glenn Research Center, Cleveland, Ohio

Co-Principal Investigators: James Lux, Greg Heckler, Jacqueline Myrann  
ISS Research & Development Conference  
Denver CO, June 2012

[www.nasa.gov](http://www.nasa.gov)

National Aeronautics and Space Administration



## SCAN Testbed Research & Technology Goals & Objectives

- **INVESTIGATE the APPLICATION of SDRS TO NASA MISSIONS**
  - Mission advantages and development/verification/operations aspects
  - On-Orbit Reconfiguration
  - More process intensive functions within the radio subsystem
- **SDR TECHNOLOGY DEVELOPMENT**
  - SDR Platforms to TRL-7
  - SDR platform hardware & waveform compliant to STRS, Foster Agency adoption
  - Understand/characterize space effects and SDR performance
- **VALIDATE FUTURE MISSION OPERATIONAL CAPABILITIES**
  - Capability representative of future missions
    - Comm data rate, performance, navigation, GPS, data processing
  - Understand SDR performance (reliability, SEE, telemetry, instrumentation)
  - Multiple and simultaneous RF Links (Ka-band, S-band, L-band/GPS)
  - Experimenter sw applications (On-board networking, DTN, routing, and security applications)

[www.nasa.gov](http://www.nasa.gov)



# SCAN Testbed Overview



- ◆ **Sponsored by the NASA Space Communications and Navigation (SCaN) Program.**
  - ◆ Across multiple Center; GRC, JPL, GSFC, JSC
- ◆ **Launch to the International Space Station (ISS) on JAXA H-II Transfer Vehicle (HTV-3) summer 2012**
  - ◆ Utilizes a Flight Releasable Attachment Mechanism (FRAM)-based payload interface and is installed on the Expedite the Processing of Experiments to Space Station (ExPRESS) Logistics Carrier (ELC) at the ISS P3 location.
- ◆ **The Flight System is a Class D payload planned to operate for five years on ISS (min design life is two years).**
  - ◆ Ground System includes a flight-Like system for new radio software development

Future Home of SCAN Testbed

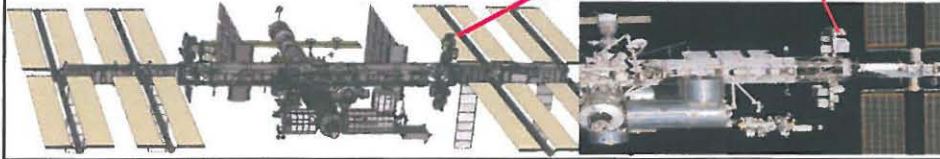
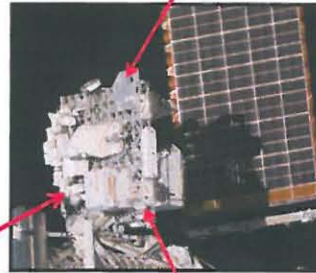

# Concept of Operations & Connectivity

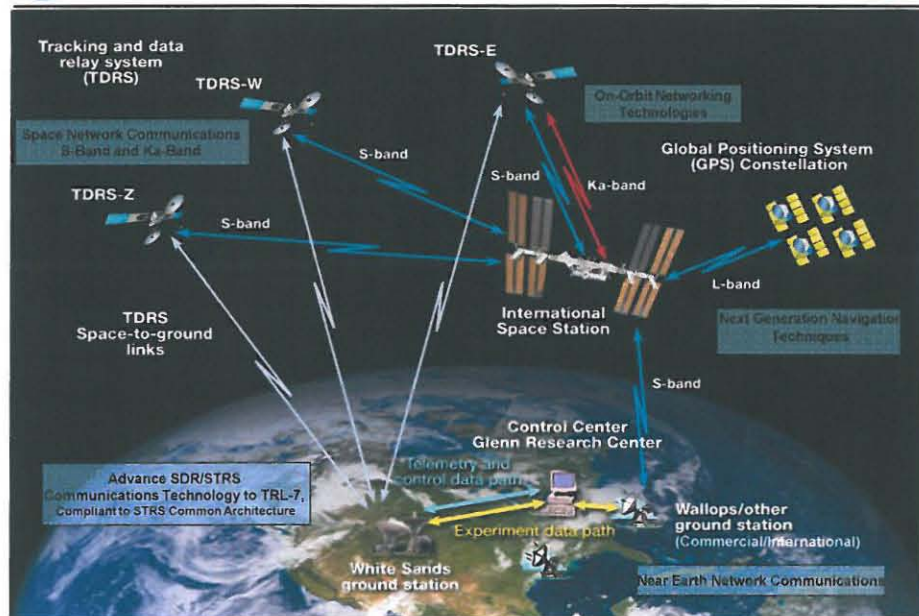





# SCAN Testbed - Flight System Overview



## Flight System Subsystems

- Mechanical/Thermal
- Avionics/Electrical
- SDRs
- RF/Antennas
- APS

EXPRESS Pallet Adapter (ExPA)-  
Flight Releasable Attachment Mechanism (FRAM)

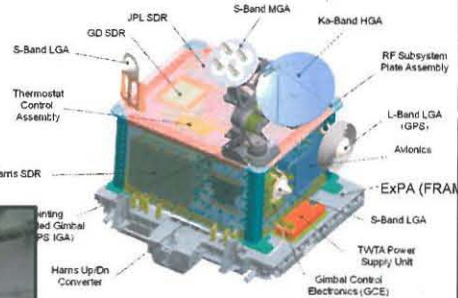

JAXA Experiment

SCAN Testbed Experiment

Installed on an EM-MP for HTV Integration

Flight System Mass w/out ExPA, lb	486
ExPA Mass, lb	260
Total Mass, lb	746

5

National Aeronautics and Space Administration



## SDRs are the core "instrument" of the SCAN Testbed Communication System

### STRS SDRs

- Software Abstraction
- Single Standard on SDR and WF

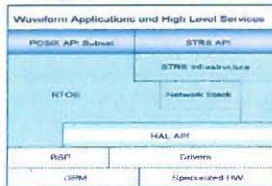

### JPL/L-3 CE

- S-band SDR
- 6 MHz wide channel
- L-band receive (GPS)
- Virtex II, Sparc Processor (100 MIPS), RTEMs
- 10 Mbps Class

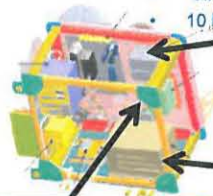

### General Dynamics

- S-band SDR
- 6 MHz wide channel
- Virtex II, ColdFire Processor (60 MIPS), VxWorks, CRAM (Chalcogenide RAM) Memory
- 10 Mbps Class



### Harris

- Ka-band SDR
- 225 MHz wide channel
- Virtex IV, AiTech-PowePC Processor (~700 MIPS), DSP (1 GFLOP), VxWorks, Scrubbing ASIC
- First Ka-band transceiver
- >100 Mbps Class



www.nasa.gov



## Software Defined Radio "SDR 101"

- Hardware and software that converts user data to over-the-air signals
- Hardware – Signal processing, RF, power, thermal
  - Shift from fixed hardware to flexible, reprogrammable hardware (FPGA, processor)
  - Traditional hardware remains at RF front end (ADC, DAC, filters, amplifiers)
- Software – Application (aka waveform), Managing (STRS)
  - Application Software – communication, navigation, networking functions
    - e.g. modulation, coding, filtering, data framing, routing, orbit determination
  - Managing Software – Controls the application software on the radio platform.
    - Loads/unloads application code and data to/from memory
    - Responsible for interprocess communications between software components
    - Provide platform services (timing, file manager, events)

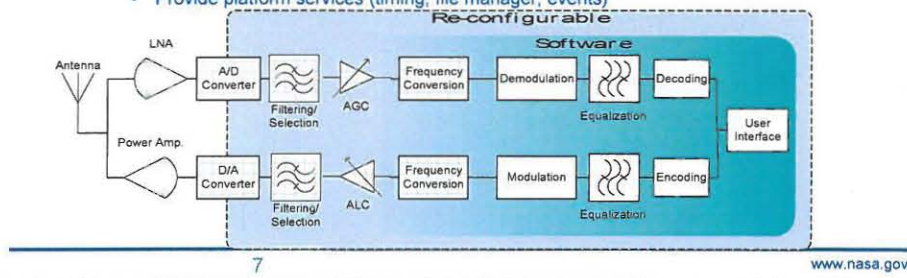

7

www.nasa.gov



## STRS Simplified View

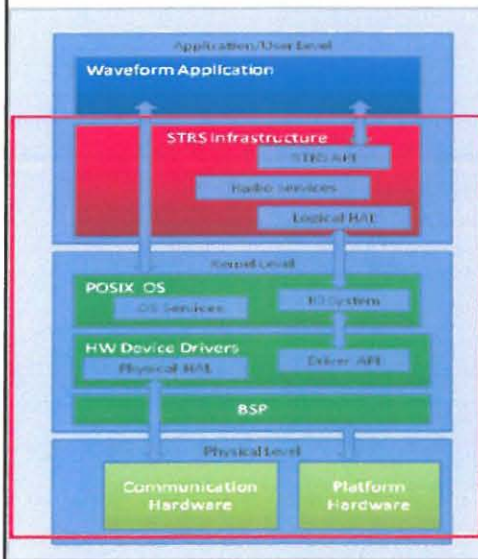

- Abstract app sw from underlying HW
  - Reduce mission dependence on radio provider for reconfigurations years after development/launch.
  - Minimum set of hardware and software interface
- Promote portability/reuse
  - Avoid proprietary application designs/implementations.
- Mission flexibility, for different levels of available resources. – scalable
- Architecture simplified by mission planning and hw resource allocation.
  - No radio hardware discovery or dynamic WF allocation change across hardware – fewer resources (e.g. power, memory)
- Enable waveform component contributions to repository for reuse

www.nasa.gov





## STRS Interface Highlights

APIs separate waveform from operating environment – enabling waveform portability.

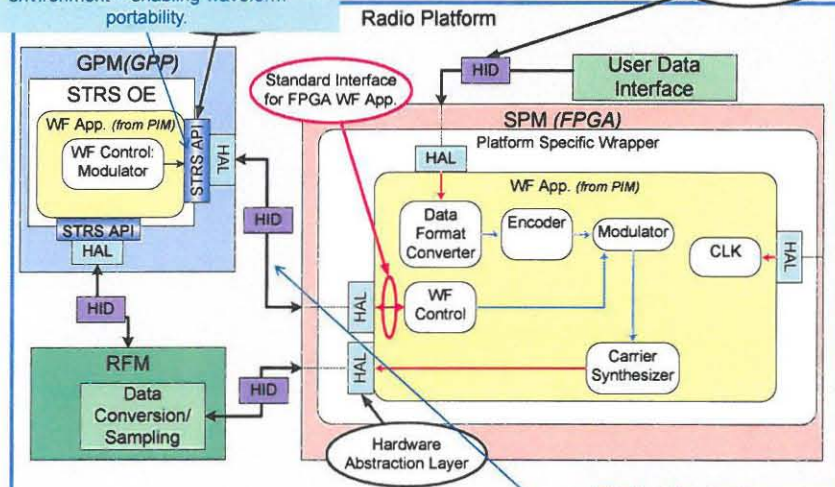

HID identifies hardware resources available to waveform developer, separating WF from HW dependency.



## SDR Developer/Operations Roles

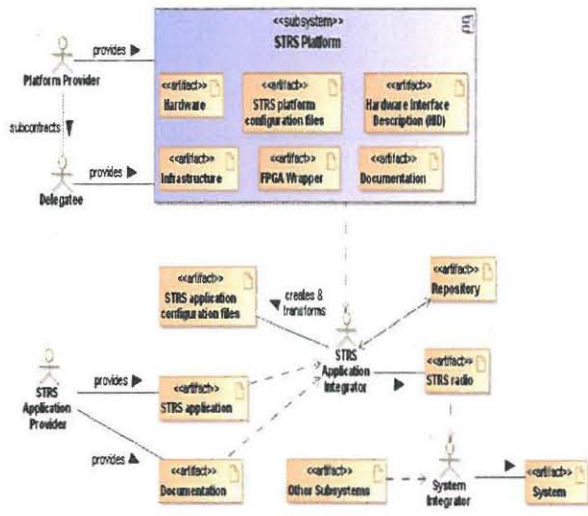

- Platform Supplier
  - Hardware
  - Operating Environment
- Waveform Developer
  - Waveform App
- SDR Integrator
  - Combines waveform applications with the platform.
  - non-SDR model, the integration is done at the radio manufacturer
- System Integrator
  - integrates the complete radio (hw/wf) with the rest of the spacecraft.



## SCaN Testbed Experiment Waveforms (Launch Capability)

TDRSS Mode	Platform Provider	Waveform Provider	Transmit (Return) Link		Receive (Forward) Link		Coding/Decoding
			Modulation	User Data Rate (kbps)	De-modulation	User Data Rate (kbps)	
S-band DG1, Mode 1	GD	GD	SQPN	24, 192	QPSK	18, 72	Rate 1/2 Viterbi
S-band DG1, Mode 2	GD	GD	SQPN	24, 192	QPSK	18, 72	Rate 1/2 Viterbi
S-band DG1, Mode 3	GD	GD	QPSK	<1000	QPSK	1000	Rate 1/2 Viterbi
S-band DG2	GD	GD	SQPSK	<1000	QPSK	1000	Rate 1/2 Viterbi
S-band DG1 Mode 2	JPL	GRC/GSFC	BPSK	24	BPSK	18	Rate 1/2 Viterbi
S-band DG2	JPL	GRC/GSFC	BPSK	192	BSPK	155	Rate 1/2 Viterbi
Ka-band DG2	Harris	Harris	SQPSK	100 Mbps 12.5 Mbps	BPSK	12.5 Mbps 3 Mbps	Rate 1/2 Viterbi

Specific waveform variations lead to numerous (>100) configurations



## Flight Test and Measurements Provide Validation of New Technologies

- **SDR Platform Technology**
  - Reconfiguration (time, reliability, operations)
  - Application Integration
  - Space Effects (SEU, processing, memory, thermal, power)
- **System Architectures**
  - Connectivity: TDRSS and ground...relay and surface
  - Multi-band, multi-TDRSS links
  - Multiple access techniques (TDRSS)
- **Communication Applications**
  - Link capacity – data rate, bandwidth efficiency, coding schemes
  - Adaptive communications
  - Data link protocol verifications
  - Link performance
    - Error performance/rate (BER), Eb/No (SNR)
    - Error distribution
  - Link characterizations



## Flight Test and Measurements Provide Validation of New Technologies

- **Demo SDR-based GPS**
  - Comm and navigation functions time-multiplexed on common hardware
  - Improved position, velocity, time (PVT)
  - TASS enhancement of GPS navigation
  - Re-broadcast of GPS corrections to other s/c
  - Navigation data fusion
- **Evaluation of new GPS**
  - New signals (L5) to be added without rebuilding hardware
- **Precision relative navigation**
  - Rendezvous and docking
- **On-Board Routing**
  - Connectivity, network characterization, link statistics
- **Delay/Disruption Tolerant Networking (DTN)**
  - Automated store-n-forward
  - Adaptive routing
  - Traffic prioritization
  - Link layer error control/cross link optimization
- **IP in Space**
- **Common Command/Data Interface Experiments**
- **Distributed Processing**
  - Efficiency, reliability



## Experimenter Access Points within SCaN TestBed System

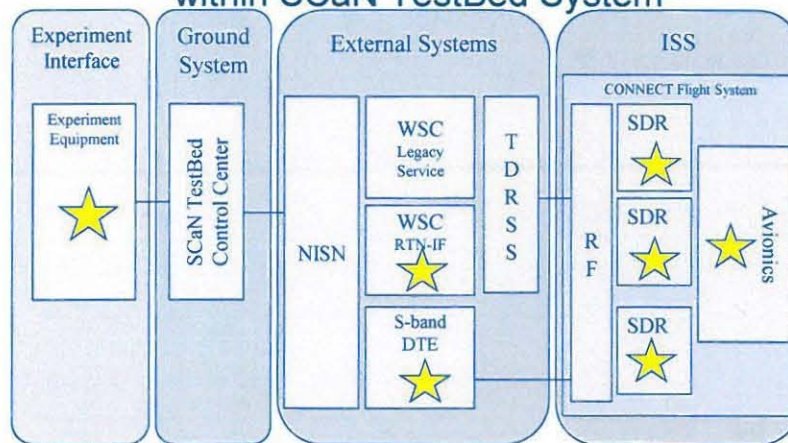

★ = Experiment Element (e.g. sw, fw, hw, component)

Experimenters have access to  
Flt SDRs, avionics, Gnd SDR, various ground points





## Call for Experiment Proposals

- After Commissioning is complete, the testbed will be available for experiments
- Experiment announcement call in mid 2012 for external experiments
  - The call will go to NASA, industry, academic partners and other government agencies
  - Experiments selected will complement experiments already selected from internal to NASA and through the SBIR process
- Goal is to develop an experiments program to utilize the SCaN Testbed for the benefit of the Space Communication and Navigation (SCaN) Program, and NASA

<http://www.fedbizopps.gov/>



## Summary – SDR Experiment on ISS

- SCaN Testbed scheduled for launch in mid-2012
- Experiments Program seeks participation by NASA, industry, academia, and OGA to use the SCAN Testbed.
  - Call for experiments released in mid 2012.
- Broad participation will create a forum to exchange ideas and results, create new experiments, new partnerships, and disseminate results
- STRS abstracts waveform from underlying hardware
  - Increase the base of domain experts around a common standard.
  - Seeking input to STRS by other agencies (standardization effort in FY12)
- SCAN Testbed reduces the risk of infusing SDRs and their applications (comm, nav, networking) into NASA missions





# Backup



## Acronym List (1 of 2)

- API – Application Programming Interface
- ASIC – Application Specific Integrated Circuit
- BER – Bit Error Rate
- BPSK – Bi-Phase Shift Keying
- BSP – Board Support Package
- CE – Cincinnati Electronics
- DSP – Digital Signal Processing
- DTE – Direct to Earth
- DTN – Disruptive Tolerant Networking
- EDAC – Error Detection and Correction
- ELC – EXPRESS Logistics Carrier
- FPGA – Field Programmable Gate Array
- FW - Firmware
- GD – General Dynamics
- GPM – General Processing Module
- GPS – Global Positioning System
- GRC – Glenn Research Center
- GSFC – Goddard Space Flight Center
- HAL – Hardware Abstraction Layer
- HID – Hardware Interface Definition
- HGA – High Gain Antenna
- HPA – High power Amplifier
- HW - Hardware
- JPL – Jet Propulsion Lab
- JSC – Johnson Space Center
- LGA – Low Gain Antenna



## Acronym List (2 of 2)

- OE – Operating Environment
- OGA – Other Government
- QPSK – Quadrature Phase Shift Keying
- PVT – Position, Velocity, Time
- RF – Radio Frequency
- RTN - Return
- RTOS – Real Time Operating System
- SDR – Software Defined Radio
- SEE – Space Environment Effects
- SEU – Single Event Upset
- SN – Space Network
- SNR – Signal-to-Noise Ratio
- SQPN – Staggered QPSK PN Spread
- SQPSK – Staggered Quadrature Phase Shift Keying
- STRS – Space Telecommunications Radio System
- SW - Software
- TDRS – Tracking Data Relay Satellite
- TDRSS – Tracking Data Relay Satellite System
- TRL – Technology Readiness level
- TWTA – Traveling Wave Tube Amplifier
- V2 – Virtex II
- V4 – Virtex IV
- WSC – White Sands Complex
- WF - Waveform



## SDRs are the core of the SCaN TestBed Communication System

### STRS SDRs

- Advance STRS/SDR Platforms to TRL-7
- Single standard on SDR and WF

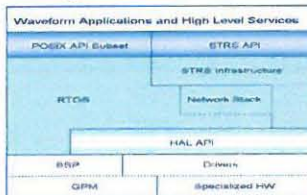

- Compliance verified w/ -tools
- inspection
- observation

### JPL/L-3 CE

- L-band receive (GPS)
- S-band SDR
- Tx: 2.2-2.3 GHz, 7W
- Rx: 2.025-2.12 GHz, (6 MHz channels)
- Virtex II, Sparc Processor (100 MIPS), RTEMs OS, EDAC



### General Dynamics

- S-band SDR
- Tx: 2.2-2.3 GHz, 8W
- Rx: 2.025-2.12 GHz (6MHz channels)
- Virtex II, ColdFire Processor (60 MIPS), VxWorks OS, CRAM (Chalcogenide RAM) Memory



### Harris

- Ka-band SDR
- Tx: 25.650 GHz, 225 MHz
- Rx: 22.680 GHz, 50 MHz
- Virtex IV, AiTech-PowePC Processor (~700 MIPS), DSP (1 GFLOP), VxWorks OS, Scrubbing ASIC
- First Ka-band transceiver
- GSE – Avionics Comm/Telem Simulator

