

GLEX-2012.03.1.8x12731

ROBOTIC LUNAR LANDER DEVELOPMENT STATUS

Dr. Greg Chavers

NASA Marshall Space Flight Center, USA, greg.chavers@nasa.gov

Benjamin Ballard*, Barbara A. Cohen†, Timothy McGee‡, Joshua Moore§, Cheryl Reed**, Cindy Stemple††

NASA Marshall Space Flight Center and John Hopkins University Applied Physics Laboratory have developed several mission concepts to place scientific and exploration payloads ranging from 10 kg to more than 200 kg on the surface of the moon. The mission concepts all use a small versatile lander that is capable of precision landing. The results to date of the lunar lander development risk reduction activities including high pressure propulsion system testing, structure and mechanism development and testing, and long cycle time battery testing will be addressed. The most visible elements of the risk reduction program are two fully autonomous lander flight test vehicles. The first utilized a high pressure cold gas system (Cold Gas Test Article) with limited flight durations while the subsequent test vehicle, known as the Warm Gas Test Article, utilizes hydrogen peroxide propellant resulting in significantly longer flight times and the ability to more fully exercise flight sensors and algorithms. The development of the Warm Gas Test Article is a system demonstration and was designed with similarity to an actual lunar lander including energy absorbing landing legs, pulsing thrusters, and flight-like software implementation. A set of outdoor flight tests to demonstrate the initial objectives of the WGTA program was completed in Nov. 2011, and will be discussed.

I. INTRODUCTION

The Robotic Lunar Lander (RLL) Development team started in 2005 to develop small and medium lunar landers in support of NASA's Exploration Systems Mission Directorate. Much work has gone into developing mission concepts and promoting risk reduction activities. One of the largest activities involves test articles, and the successful lunar descent demonstration of the Cold Gas Test Article and the Warm Gas Test Article will be discussed.

II. MISSION CONCEPT

To optimize mass and reduce complexity, current trade studies suggest separation from the launch vehicle following the trans-lunar injection burn. During the trans-lunar phase following separation, the vehicle must use its propulsion system to perform trajectory correction maneuvers, attitude control (including spin stabilization), nutation damping, and

targeting for the landing site. At lunar approach, a solid rocket motor (SRM) will slow the vehicle. After separation from the SRM casing, the vehicle will use bi-propellant thrusters to control the descent to the surface. Smaller Attitude Control System (ACS) thrusters will help maintain stability during this phase.

Preferred landing sites are in the polar regions of the moon, due to the increased likelihood of volatiles in these regions. On-board navigation will be essential for autonomously landing at a preselected site. As concentrations of volatiles may be much higher in the permanently shaded regions of the rugged craters, a rover may be delivered and deployed. This would require a larger class of lander to handle payloads more than 200 kg.

III. LANDER ARCHITECTURE

Landing craft designed to meet these types of missions require very specific capabilities. Referred

* Johns Hopkins University Applied Physics Laboratory, USA, Ben.Ballard@jhuapl.edu

† NASA Marshall Space Flight Center, USA, Barbara.A.Cohen@nasa.gov

‡ Johns Hopkins University Applied Physics Laboratory, USA, Timothy.McGee@jhuapl.edu

§ NASA Marshall Space Flight Center, USA, Joshua.Moore@nasa.gov

** Johns Hopkins University Applied Physics Laboratory, USA, Cheryl.Reed@jhuapl.edu

†† NASA Marshall Space Flight Center, USA, Cindy.Stemple@nasa.gov

to as small and medium landers, they must have precision landing capability and be accommodating of a wide variety of payloads.

Two configurations are being studied and matured. The small tripod lander is based around a concept called Solar Array Battery (SAB). As an ideal configuration for an equatorial lander, science data could be collected at a single stationary location. Concept for the tripod lander is shown in Table 1.

Should a mobility aspect be desired, a medium sized pallet lander would be required. Current design points allow for approximately a 400 kg rover to be delivered to the lunar surface. An SRM such as the Star-48V would provide the primary braking burn,

Power	<ul style="list-style-type: none"> Solar array for cruise and lunar day Secondary batteries for lunar night Power system electronics
Propulsion	<ul style="list-style-type: none"> Bi-Propellant 445 N axial DACS Engines (6) 30 N ACS DACS Engines (12) 2 Custom metal diaphragm tanks
Avionics	<ul style="list-style-type: none"> Integrated Flight Computer and Power Distribution
RF	<ul style="list-style-type: none"> S-band 1-WRF transmit power Antenna coverage for nearside operations
GN&C	<ul style="list-style-type: none"> Star Tracker (dual) IMU Radar Altimeter Landing Cameras (2)
Structure	<ul style="list-style-type: none"> Composite Primary Structure

Table 1: Solar Array Battery concept

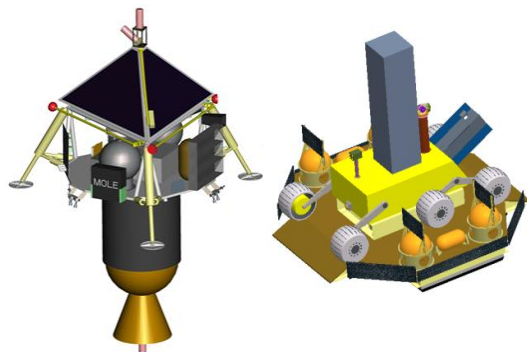

Figure 1: Solar Array Battery Tripod (left) and Medium Pallet concept (right)

Power	<ul style="list-style-type: none"> Body mounted solar panel for cruise phase power, jettisoned at SRM burnout during landing Rover power maintenance during cruise Small battery on lander for cruise and landing peak power
Propulsion	<ul style="list-style-type: none"> Bi-Prop MMH/MON-25 Main thrusters (12) 445 N DACS ACS thrusters (12) 30 N DACS Custom metal diaphragm oxidizer and fuel tanks
Avionics	<ul style="list-style-type: none"> Avionics “offboard” (on rover)
RF	<ul style="list-style-type: none"> X/Ka Transceiver, X-band uplink & downlink, LGA on lander
GN&C	<ul style="list-style-type: none"> IMU, radar altimeter, sun sensors, star tracker COTS TRN for precision landing
Structure	<ul style="list-style-type: none"> Welded aluminum frame structure

Table 2: Pallet Lander design concept

taking advantage of its thrust vector control. The pallet lander includes all propulsion components for decent control and landing, with navigation being handled by the sensors and avionics on the rover. Small landing pads would be used instead of legs to facilitate rover egress. Current concepts leverage off previous xPRP and LPVE concepts. Additional details are shown in Table 2.

IV. LANDER SYSTEM TESTING

The most visible elements of the risk reduction are two fully autonomous vehicles. The team chose to use an incremental approach with a series of test articles to develop, test, and validate the technologies required for lunar lander.

I.I Cold Gas Test Article

The first test article lander, shown in Figure 2 uses compressed air to demonstrate closed-loop control with durations up to 10 seconds. The algorithms, which could be quickly tweaked and tested, performed more than 150 flights. This test article allowed for the demonstration of control using pulsed thrusters. To make the environment more

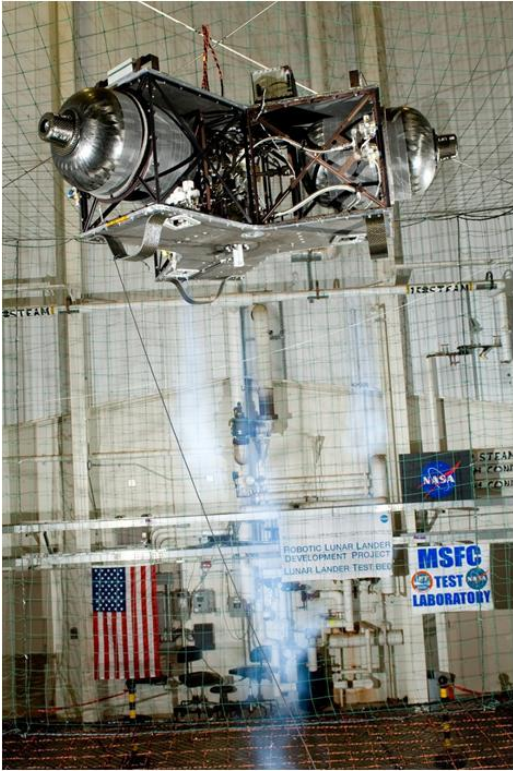

Figure 2: Cold Gas Test Article in flight at MSFC testing facility.

closely resemble that of the lunar environment, a larger thruster was mounted along the vehicle centerline. This effectively offsets approximately 5/6ths the weight to match lunar gravity. The limited payload capacity and flight time led to the need for a more robust test article.

I.II Warm Gas Test Article

The second test article lander is called the “warm gas” test article (WGTA) since it uses hydrogen peroxide monopropellant, catalyzed by silver screens. Six indoor test flights [1] and twelve outdoor flights, as long as 42 seconds and as high as 30 meters, have allowed for validation of flight or flight-like sensors, algorithms, software implementations, pulsed thrusters, structures, and mechanisms. Discussion here will focus on mission applicable development, but some mention will be made of major developments required for ground based testing.

The WGTA, shown in Figure 3, is a tripod lander. As tested, the vehicle weighs approximately 206 kg dry. Two composite overwrap pressure vessels (COPV) can support up to 110 kg of propellant, using two additional COPVs for a nitrogen pressurization system. The majority of structural components, including the two circular decks and three shock absorbing legs, were built from

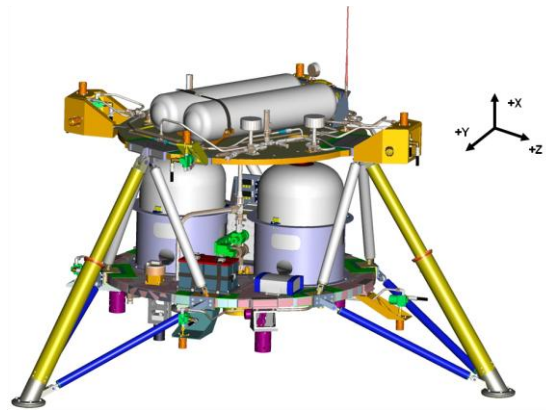

Figure 3: WGTA Vehicle

aluminum parts to ensure compatibility with the easily oxidized peroxide.

The WGTA guidance, navigation and control (GNC) system is tasked with controlling the vehicle in the terminal descent phase and landing [2].

Sensors were selected to provide flight-like feedback to ensure applicability to a lunar mission. The GNC sensor suite, shown in Figure 4, includes an inertial measurement unit, radar altimeter, optical camera, and ground contact sensors. As shown in Table 3, the sensors provide all required data for successful navigation.

The LN200 IMU provides angular rates and three-axis accelerations which are used to derive velocities and positions in the vehicle coordinate frame. The Northrop Grumman produced LN200 was chosen for its heritage in past space mission. The non-space qualified version used on WGTA proved to be an affordable, adequate sensor for the development effort.

The Type 2 Miniature Radar Altimeter (MRA) provides vertical position from 0.2 to 100 meters, covering the full altitude range of the WGTA[3]. The Roke produced MRA, provides a low cost, power, and mass representation of altimeter data that could be delivered by a space qualified sensor. For the actual lunar mission, a Honeywell HG8500 series altimeter has been acquired. It was selected for its heritage with Mars landing missions. Parallel testing of this sensor is being conducted as part of this development project.

The Illunis RMV-420, used with an Active Silicon Phoenix D48CL Frame Grabber provides highly accurate, synchronous image capture. These images from this nadir facing camera can be used to derive lateral velocity and relative position. This camera provides representative images for

Sensor	Vertical Position	Lateral Position	Vertical Velocity	Lateral Velocity	Angular Rates
IMU	X	X	X	X	X
MRA	X		X		
Camera		X		X	

Table 3: Sensor Data

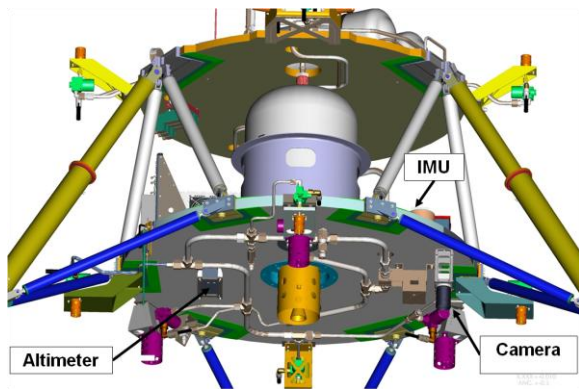

Figure 4: WGTA Sensor Configuration

developing the algorithms, but would be replaced with a space qualified sensor for the lunar missions.

Contact switched mounted on the main pivot point of the legs provides a positive indication that the vehicle on the ground and can safely terminate the propulsion system.

The data provided by the GNC sensor suite is processed in the Lander Avionics Unit (LAU), provided by Southwestern Research Institute (SwRI). The LAU includes a flight-like BAE RAD750 processor, though it could support alternate single board computers when faster models are developed and qualified.

Flight-like software is built around the core flight executive (cFE) modular software environment developed by NASA Goddard Space Flight Center. The cFE provides abstraction layers and multiple key services including board initialization, event logging, and a software bus to promote reusability across processors and missions. Additional flight applicable applications were developed as part of this program, the Least-squares Optical Flow (LSOF) application and the Guidance Navigation and Control application, dubbed GNCA. These applications, developed using Mathworks' Simulink and Embedded Matlab software packages, were initially tested in a Simulink simulation environment. The Real Time Workshop package by Mathworks was used to autogenerate C code to execute the GNC algorithms on the flight computer.

The LSOF Algorithm is being explored for use in space flight environments using a relatively low performance space qualified processor such as BAE's RAD750, and the algorithm itself can require significant CPU resources. As a result of this separation, a major aspect of the design effort was focused on the communication protocol between the image ingest software, the LSOF Algorithm, and the GNC navigation filter to handle processing delays.

Early in the planning for the WGTA, the decision was made to utilize the same ground data system software for command and control of the WGTA as would be used during command and control of a robotic lunar lander for a robotic lunar lander mission. This allowed the ground data system and mission operations personnel to gain experience with the L3 "InControl" ground data system software. Throughout the WGTA development, the ground system and mission operations team participated in the design and development of the ground/flight software interfaces, the integration and testing of the ground/flight software, and development of the flight test operations procedures. During software integration and testing, the team embraced the concept of "test like you fly, fly like you test". The entire life cycle for ground system and mission operations was exercised: software installation/configuration, command and telemetry database build, command and telemetry display development, command script development, operations product validation, real-time command & telemetry processing, telemetry playback, telemetry data archiving, and post-flight data retrievals, including telemetry plots and history reports.

During each WGTA test flight, the ground system and mission operations personnel operated two console positions, Command (CMD) and Data (DAT). CMD uplinked the guidance, navigation, and control (GNC) sequences to the flight computer and issued commands to initiate flight software transitions, open/close propulsion system valves, and power on avionics equipment. DAT monitored and reported vehicle telemetry and was responsible for making telemetry-based flight abort calls. The team also developed Flight Rules for off-nominal events and pre-defined responses that might occur during the autonomous phases of the WGTA flight. All are activities that would be performed during development and execution of an actual robotic lunar lander mission. Though only two command and telemetry flight operations consoles were necessary for WGTA, the development processes are certainly scalable for a larger team in support of robotic lunar lander mission.

Pulsed thrusters provide flight like attitude and lunar descent control, except with thrust provided by the hydrogen peroxide propulsion system. Hydrogen peroxide was chosen for its benign decomposition products, steam and oxygen, despite its reduced specific impulse compared to traditional rocket propellants. This system feeds 12 attitude control thrusters, three descent thrusters, and a non-flight-like earth gravity cancelation (EGC) thruster. The EGC allows for a throttleable centerline thrust vector to offset 5/6ths the constantly changing mass of the lander. This allows for a better simulation of the lunar gravitational environment.

Two sets of structural decks were designed and built. The flight-like composite decks were designed and built to provide the team experience working with composite/aluminum honeycomb sandwich. Since the upper and lower decks are such large elements of the structure, the mass efficiency of the composite construction is advantageous. After a series of delays in the manufacturing process, the composite decks were completed several months after the scheduled need date. For an earlier testing start date, a pair of aluminum orthogrid decks were designed and manufactured in-house at MSFC. Both sets of decks were used in the mechanical and the thermal modeling.

As they are required for a lunar tripod lander, APL designed and tested shock absorbing legs. These mechanisms make use of a hydraulic damper for the primary, telescoping landing shock, but provide a single use, crushable honeycomb should the expected landing loads be exceeded. As testing continued, APL was able to refine each approximately 13 kg leg to reduce the mass by 1/3. The design was highly successful accommodating the harsh testing environments and varying landing conditions [4].

With a project kick-off in September 2009, WGTA design and fabrication proceeded quickly to complete functional testing in February 2011. Functional testing was conducted in a variety of configurations: stationary ground testing, crane MRA, camera, and IMU validation, and a GNC polarity test that utilized low cost skateboard testing to verify lateral translations. Once functionality was checked, the vehicle proceeded in to a strap-down hot-fire test program. This allowed checkout of the pressure and propellant systems, providing high speed pressure data that was used to validate flow rate models. Temperature measurements were taken on many surfaces to validate the thermal models in preparation for flight. Specific attention was paid to thermal soak back conditions. This is generally a bounding condition on a space vehicle, and applies in



Figure 5: Infrared view of WGTA strap-down hot fire test

this case where hydrogen peroxide can begin self-decomposition at high temperatures. An example infrared view of a hot fire test is shown in Figure 5. Additional remotely viewed, live video cameras were essential in the diagnosis of problems, as well as monitoring the safety of the situation.

With strapdown testing complete in March 2011, indoor free-flight testing preparations began in April, and a set of six successful indoor flight tests were performed during June and July [1]. The first two indoor tests were tethered to the ground using shock absorbing lines attached to each leg, thus limiting the flight altitude, distance and yaw angle, precluding tip over. Later indoor tests, including a lateral translation of 4 m and an ascent to 5 m, were allowed to fly untethered. This testing model of functional checkouts in a controlled, tethered setup is applied every time there is a significant configuration change to the system. The six indoor flight tests demonstrated stable control of the vehicle during hovers, translations, ascents and descents.

Following the indoor testing, testing was transitioned to an outdoor test range. The technical objective of the outdoor test flights during September through November was to increase the flight envelope of the vehicle to include higher rate translations at up to 2 m/s, descents from 30 m or greater, and a 90 degree slew of the vehicle around the vertical axis. A secondary objective of the outdoor test flights was to demonstrate optical velocity estimation on the vehicle. Similar to the indoor test sequence, initial outdoor tests were performed using tethers to verify vehicle performance and operation of the flight termination sequence (FTS). Following these initial checkout tests, the flight envelope was gradually increased leading to a lateral 10 m translation while descending

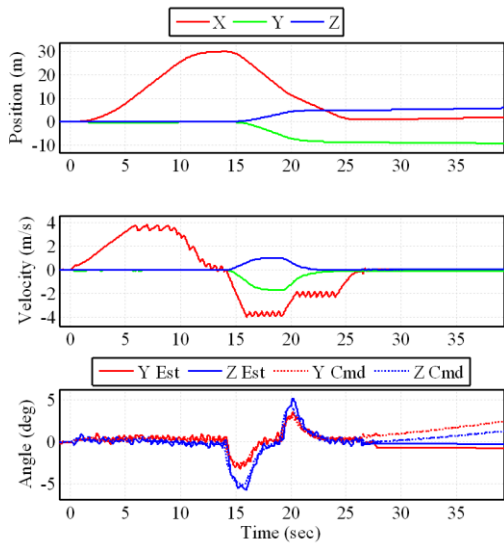

Figure 6: Flight Data from 30 m Descent with 10 m Lateral Translation

from 30 m to approximate a terminal lunar descent, illustrated in Figure 6.

The largest obstacle during the outdoor test was a gradual decrease in thruster performance during later flights resulting from slow catalyst degradation that is not uncommon with hydrogen peroxide systems. While the reduced thrust didn't compromise the safety of the system, it did prevent several flights from fully achieving their objectives. The demonstration of the optical velocity algorithms was also limited by degraded propellant decomposition. The image processing code successfully ran on the flight processor and communicated with the navigation filter, although, the velocity measurements were autonomously rejected because of poor image quality resulting from visible thruster exhaust from the field of view. In mid-November a checkout and refurbishment of the catalyst beds was performed, and the final two test flights demonstrated the restoration of the system to its nominal performance. Overall, the outdoor test sequence proved to be very successful in demonstrating the flight capabilities of the vehicle. The sequence of performed tests is summarized in Table 4.

Objectives	Max. Altitude (m)	Flight Time (s)	Status
Tethered checkout of infrastructure	0.8	12.0	success
Tethered checkout of FTS	0.8	12.0	success
1 m height, 10 m translate at 1 m/s	1.0	30.0	unsuccessful (auto aborted takeoff after missed avionics packet)
0.6 m height, 10 m translate at 1 m/s	0.6	30.0	success
1 m height, 10 m translate at 2 m/s, slew 90°	1.0	42.0	unsuccessful (insufficient thrust)
1 m height, 10 m translate at 2 m/s, slew 90°	1.0	30.0	success
Ascend to 10 m, hover, translate 10 m at 2 m/s, descend at (2, 1) m/s	10.0	30.0	success
Ascend to 10 m, hover, translate 10 m at 2 m/s, descend at (2, 1) m/s	10.0	17.0	partial (manual abort commanded at 10 m)
Ascend at 0.5 m/s, hover 6 sec, descend at 0.5 m/s	1.0	10.0	success
Ascend to 10 m, hover, translate 10 m at 2 m/s, descend at (2, 1) m/s	10.0	30.0	success
Ascend to 30 m at 3.7m/s, translate 10 m while descending at (3.7,2,1) m/s, brief hover at 1 m	30.0	27.0	success
Ascend to 10 m, translate 10 meters while descending to 2 m, ascend to 10 meters, descend back to starting point with brief hover prior to touch down.	10.0	17.0	partial (soft touchdown and manual abort after half maneuver)
Tethered checkout of catalyst bed refurbishment.	0.8	13.0	success
Ascend to 10 m, hover, translate 10 m at 2 m/s, descend at (2, 1) m/s	10.0	30.0	success

Table 4: WGTA flight profiles performed during outdoor testing in 2011



Figure 7: WGTA outdoor test flight, altitude 10 meters

System testing of WGTA will continue through 2012 in an effort to mature an additional optical navigation package. This package will deliver automated rendezvous and capture (AR&C) to the lander, allowing it to target a very specific landing site. This future testing will allow for incremental development, beginning with running AR&C outside of the control loop, and culminating in full closed loop navigation.

V. SUBSYSTEM RISK REDUCTION

Subsystem risk reduction activities have been undertaken with a focus on areas that are common to many possible lander mission scenarios. The goal is to mitigate development risk while increasing the technology readiness level in critical areas.

V.I Propulsion

High thrust to weight thrusters that have extensive flight heritage in Department of Defense atmospheric flight applications show much promise for space use with two major use case changes: extended burn times, and much reduced operating temperature. Testing of two Missile Defense Agency (MDA) heritage thrusters was completed during 2009 and 2010 in the vacuum chamber of White Sands Test Facility (WSTF), and is shown in Figure 8. These tests included variations in pulse strains,

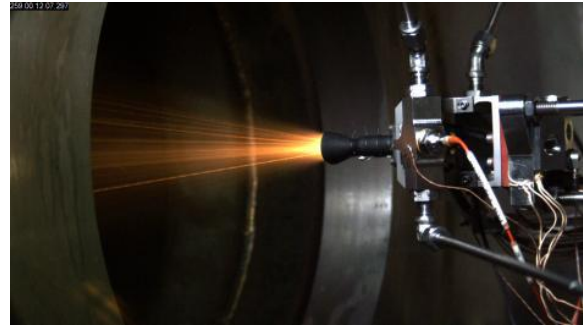

Figure 8: Thruster testing at WSTF

chamber pressures, propellant mass ratios, long duration burns, and representative lander mission duty cycles. This testing was performed using MON-25 (nitric oxide in dinitrogen tetroxide/nitrogen dioxide) and Monomethylhydrazine (MMH). Despite the testing being performed at room temperature, this MON-25/MMH combination allows for a much lower freezing point of the propellant system. With less heater power needed to warm the fuel lines, the overall power budget is reduced.

This testing showed that the heritage hardware worked as expected. The combustion was stable, with the exception of some random combustion roughness. It was also determined that the softgoods used on the valves (Chemraz or Kalrez) only lasted a few days.

Additional design work is currently ongoing in an effort to refine the design of these MDA high thrust-to-weight thrusters to better meet NASA's exploration needs. These In Space Engine (ISE) design refinements will improve thruster performance and the capability to operate in long-duration, high-pulse burns and short-duration, low-impulse burns. The thrusters will operate with a lower inlet pressure, allowing the use of lower weight propellant tanks. The design improvement will also include redundant features, valve and injector redesign, high temperature materials, and thermal-vacuum life capability for planned NASA operations. This ISE technology is cross-cutting because it is applicable to Low Earth Orbit and Geosynchronous Earth Orbit (LEO/GEO) spacecraft, Lunar and Mars landers, and planetary orbiters. Geophysical lunar network mission studies indicate that such a propulsion system is an enabling technology for small spacecraft which often have extreme constraints in mass and system packaging.

Additional activity involved proving the ability of higher pressure regulators. Increasing from 4,000 psig to 10,000 psig allows for a lower mass pressure system. Regulator characterization and response

testing showed the expected performance for flow control on various multi-thruster mission profiles.

For these multi-thruster configurations, the thrusters are expected to operate simultaneously, causing substantial flow interactions. Modeling and testing were used to investigate the water hammer effects. The results from these tests will guide the thruster operation profiles and propulsion system configuration design.

V.II Power

High risk is associated with the current lack of performance data for primary and secondary batteries in lunar thermal environments. A test series at MSFC is working to reduce the risks associated with the secondary batteries used for long duration lunar missions. Though Lithium Iron Phosphate and Lithium Cobalt Oxide batteries have successfully completed accelerated testing, the Lithium Cobalt Oxide batteries have only completed a year and a half of real time testing. Real time testing for the Lithium Iron Phosphate batteries over a three month interval has been completed. The testing to date shows that both battery designs are viable for a lunar lander mission.

V.III Guidance, Navigation, and Control

In addition to the GN&C activities utilizing the Test Bed for testing, the team worked with ATK to quantify the variability in solid rocket motor performance. Current mission designs require high accuracy landing position constraints (about 100 m). While solid rocket motors have been used for braking burns, they have not been expected to make precision landings. Work is continuing to characterize these variables.

V.IV Thermal

The extreme temperatures of the descent thruster plume impingement on nearby surfaces exceed the working temperatures of normal MLI. Design and fabrication of High Temperature MLI has been completed, with testing planned for 2012.

In pursuit of the ability to vary the WEB (Warm Electronics Box) heat rejection from that required to operate in the lunar day to that required to conserve power during the lunar night, the thermal concept includes connecting the isolated WEB to the radiator via a variable link. This link is intended to provide very good thermal conductance when efficient heat transport/rejection is needed but very high thermal resistance when the WEB is trying to conserve its heat. Risk reduction activities have focused on the identification, development and characterization of potential means of variable conductance heat transport from the WEB. Demonstration units based on two phase heat pipe and loop heat pipe technology

have been built and tested to assess unique attributes relevant to the variable link functionality. In testing, these technologies demonstrated success toward providing the desired functionality.

V.V Structures

The objective of the landing stability testing was to study the landing characteristics of a 3-leg subscale lunar lander and to develop a computer model that simulates the landing dynamics and motion of this lander. By understanding these landing characteristics, the stability limits of the lander can be determined.

APL has completed stability testing for three leg landers. Assessment of varying landing and impact conditions necessitated the need for analysis and test. Analysis was performed using the Adams modeling software package. Testing was done using small scale model similar to WGTA. The testing was performed to validate the simulations so that they can support alternate landing parameters that follow a lunar descent. The model developed using the test results will be used as a tool for predicting the stability and overall landing characteristics of various lander designs and concepts.

V.VI Avionics

Additional processing power may be required for advanced navigation algorithms. APL has designed, built and completed environmental testing on a single board Aeroflex LEON3 processor based computer. A board based on this prototype would be very valuable in supporting a low-power, processor intensive optically navigated landing.

VI. CONCLUSIONS

NASA's Marshall Space Flight Center and Johns Hopkins University Applied Physics Laboratory achieved great success in demonstrating control of the Warm Gas Test Article during hovers, translations, rotations and ascents up to 30 meters. These tests and risk reduction activities are of great value as they closely resemble a descent to the lunar surface.

VII. REFERENCES

1. McGee, Timothy G, et al. "NASA's Robotic Lunar Lander Development Project: Initial Flight Testing Results of a Robotic Lunar Lander Test-Bed." Cape Town, South Africa, 2011.
2. McGee, T., Kaidy, J., Reid, D. Oxtan, G., and Hannan, M. "Guidance, Navigation, and Control Development for a Robotic Lunar Lander Test-bed", 2011 American Astronautical Society Guidance, Navigation, and Control Conference, February 2011.
3. "Roke Miniature Radar Altimeter, MRA Type 2." December 2010. <http://www.roke.co.uk/resources/datasheets/MRA-Type-2.pdf>.
4. Cole, Timothy J., et. al. The Mechanical Design of an Earth-based Demonstrator for the Robotic Lunar Lander Development Project. GLEX-2012.03.P.4x12733, 2012.