

US008265792B2

(12) **United States Patent**
Wampler, II et al.(10) **Patent No.:** **US 8,265,792 B2**(45) **Date of Patent:** **Sep. 11, 2012**(54) **METHOD AND APPARATUS FOR CALIBRATING MULTI-AXIS LOAD CELLS IN A DEXTEROUS ROBOT**(75) Inventors: **Charles W. Wampler, II**, Birmingham, MI (US); **Robert J. Platt, Jr.**, Cambridge, MA (US)(73) Assignees: **GM Global Technology Operations LLC**, Detroit, MI (US); **The United States of America as Represented by the Administrator of the National Aeronautics and Space Administration**, Washington, DC (US)

(*) Notice: Subject to any disclaimer, the term of this patent is extended or adjusted under 35 U.S.C. 154(b) by 401 days.

(21) Appl. No.: **12/760,954**(22) Filed: **Apr. 15, 2010**(65) **Prior Publication Data**

US 2011/0257784 A1 Oct. 20, 2011

(51) **Int. Cl.**
G05B 19/04 (2006.01)(52) **U.S. Cl.** **700/254; 700/260**(58) **Field of Classification Search** **700/254, 700/260**

See application file for complete search history.

(56) **References Cited**

U.S. PATENT DOCUMENTS

4,132,318 A *	1/1979	Wang et al.	414/591
6,070,109 A *	5/2000	McGee et al.	700/259
6,292,716 B1 *	9/2001	Moore, Jr. et al.	700/260
6,952,629 B2 *	10/2005	Takamura et al.	700/259
8,175,749 B2 *	5/2012	Tsusaka et al.	700/254
8,185,243 B2 *	5/2012	Okazaki	700/260
8,195,334 B2 *	6/2012	Fukushima et al.	700/260

* cited by examiner

Primary Examiner — Eric Culbreth(74) *Attorney, Agent, or Firm* — Quinn Law Group, PLLC(57) **ABSTRACT**

A robotic system includes a dexterous robot having robotic joints, angle sensors adapted for measuring joint angles at a corresponding one of the joints, load cells for measuring a set of strain values imparted to a corresponding one of the load cells during a predetermined pose of the robot, and a host machine. The host machine is electrically connected to the load cells and angle sensors, and receives the joint angle values and strain values during the predetermined pose. The robot presses together mating pairs of load cells to form the poses. The host machine executes an algorithm to process the joint angles and strain values, and from the set of all calibration matrices that minimize error in force balance equations, selects the set of calibration matrices that is closest in a value to a pre-specified value. A method for calibrating the load cells via the algorithm is also provided.

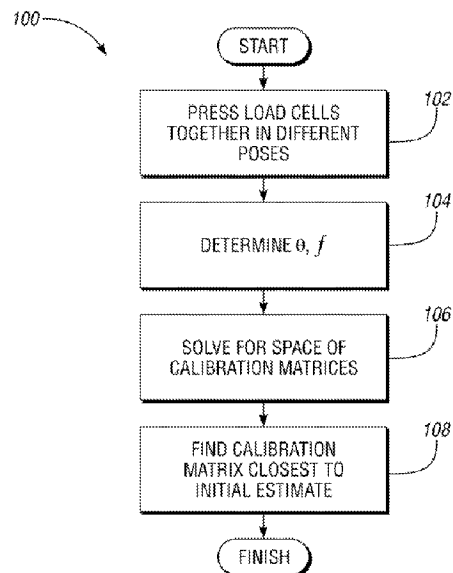
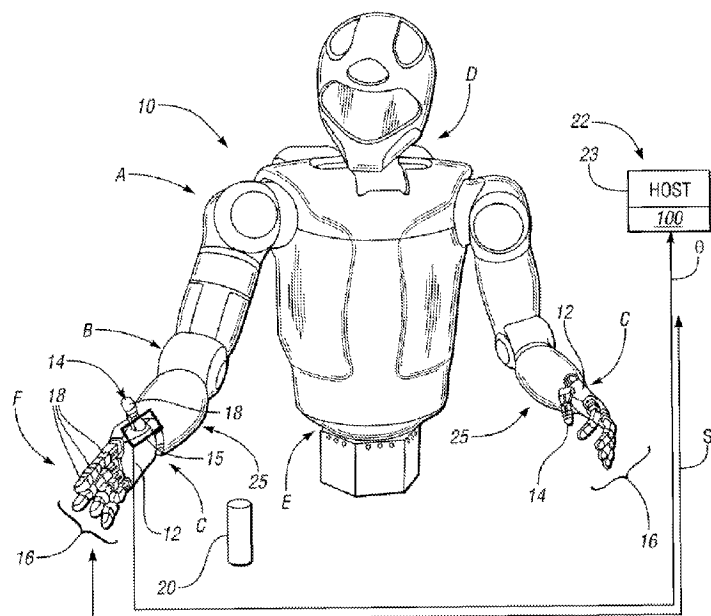
17 Claims, 2 Drawing Sheets

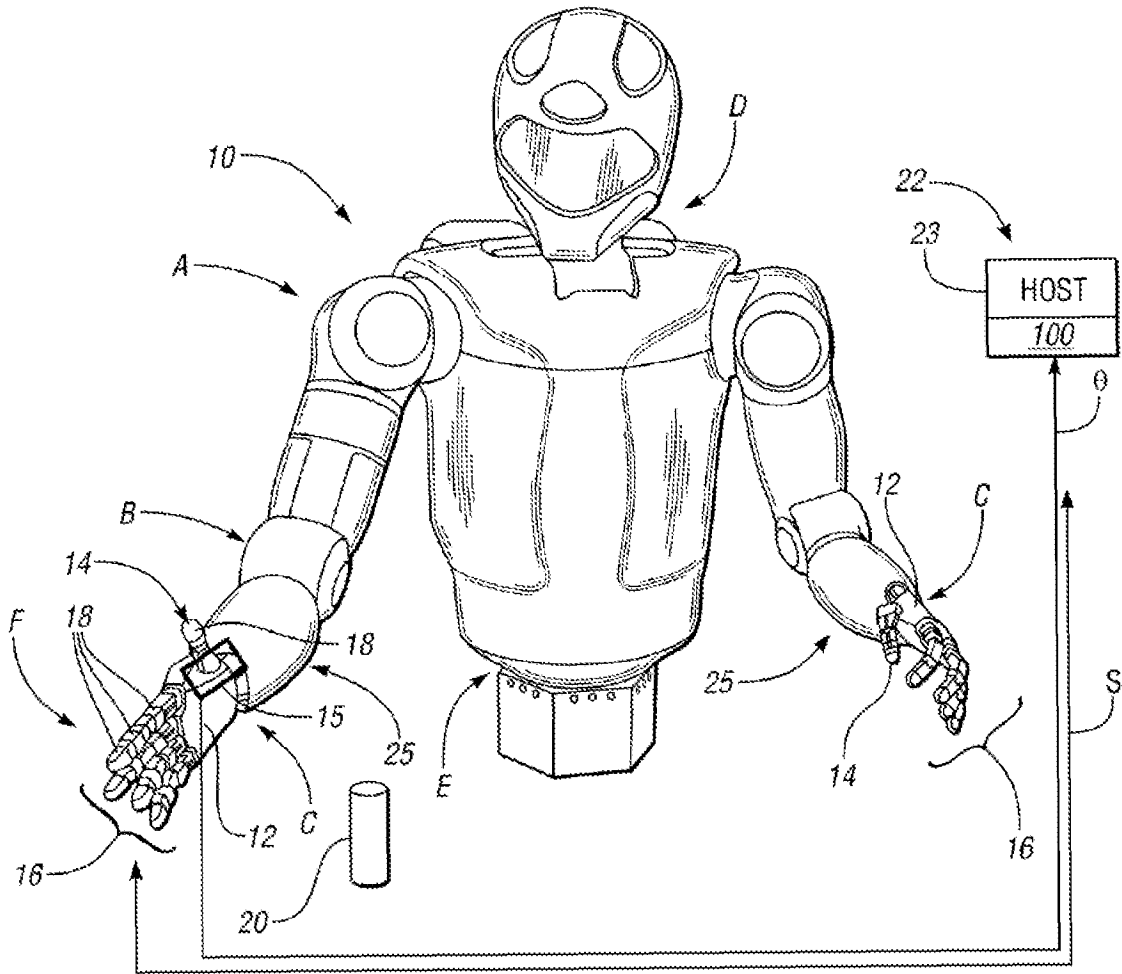

FIG. 1

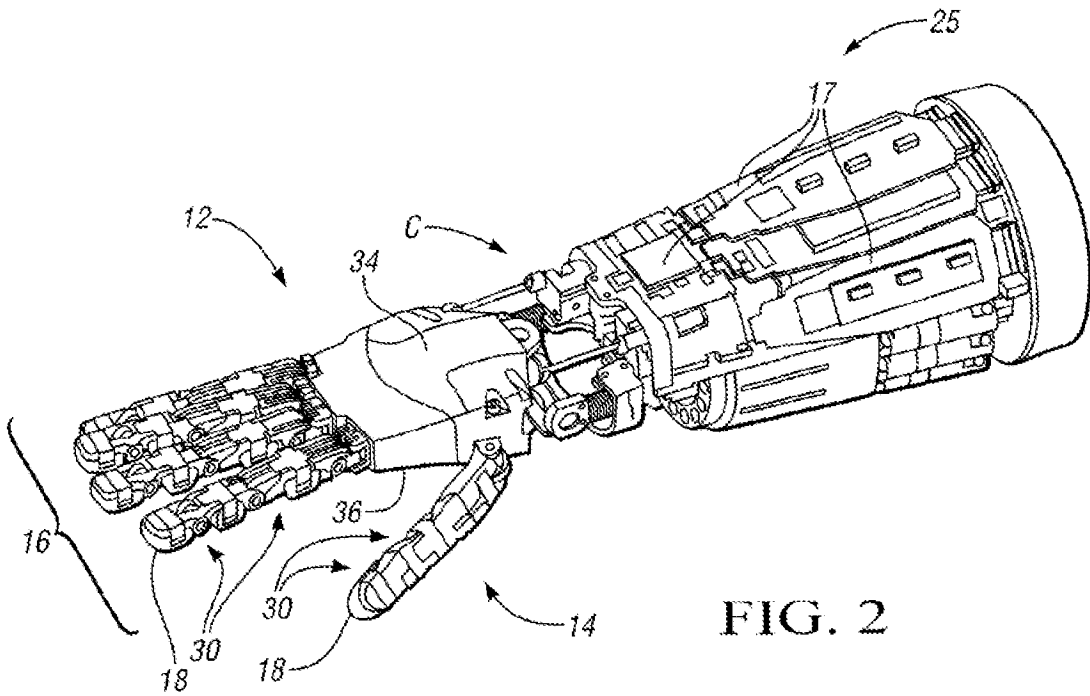

FIG. 2

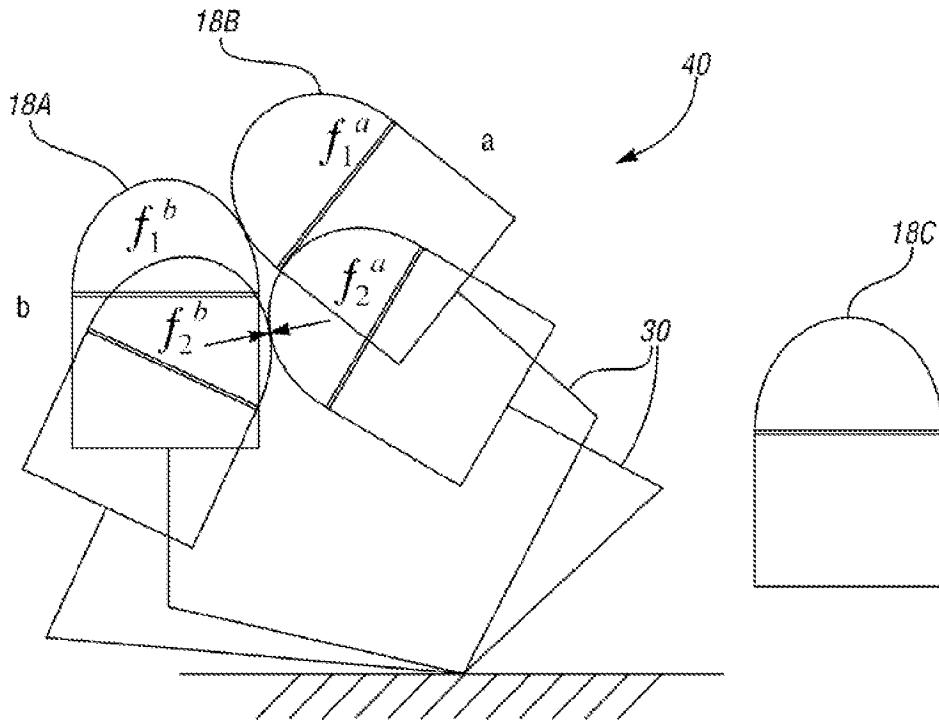

FIG. 3

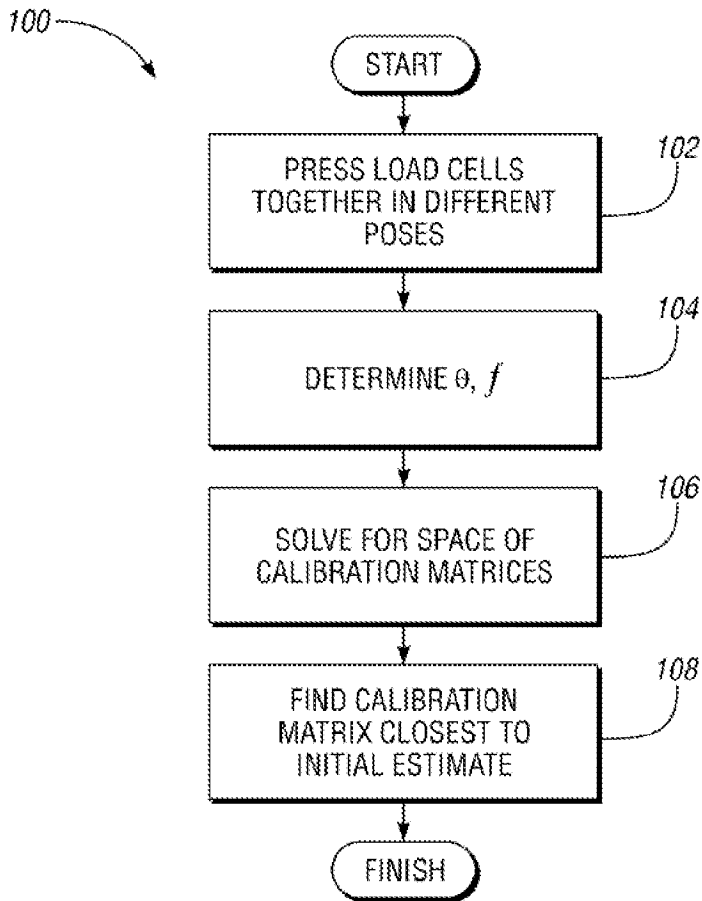

FIG. 4

1

METHOD AND APPARATUS FOR CALIBRATING MULTI-AXIS LOAD CELLS IN A DEXTEROUS ROBOT

STATEMENT REGARDING FEDERALLY
SPONSORED RESEARCH OR DEVELOPMENT

This invention was made with government support under NASA Space Act Agreement number SAA-AT-07-003. The government may have certain rights in the invention.

TECHNICAL FIELD

The present invention relates to the calibration of strain sensors or load cells of the type used by a dexterous robot.

BACKGROUND OF THE INVENTION

Robots are able to grasp and manipulate objects using a series of linkages, which in turn are interconnected via one or more motor-driven robotic joints. End-effectors are the particular linkages used to perform a given task at hand, e.g., the grasping of a work tool or other object. Humanoid robots are a dexterous type of robot having an approximately human structure or appearance, whether a full body, a torso, a hand, or another appendage. The structural complexity of a dexterous robot is largely dependent upon the complexity of the commanded work task.

Due to the wide spectrum of work tasks that can be performed by a dexterous robot, a complex sense of touch is often required to enable handling of objects in a precise and reliable manner. Miniature strain sensors or multi-axis load cells are one possible sensor type adapted for measuring linear force and torque at or along various contact surfaces, e.g., between mating fingers and/or a thumb of the same or different robotic hands.

SUMMARY OF THE INVENTION

Accordingly, a method and apparatus are provided herein that enable the in-situ calibration of multi-axis load cells used aboard a dexterous humanoid robot, i.e., calibration of the load cells while the load cells remain integrated within the architecture of the robot, and therefore without resorting to the use of an external calibration jig. In one embodiment, the load cells are integrated into different contact surfaces of an anthropomorphic hand of a dexterous robot. The robot is controlled such that mating pairs of the load cells are automatically pressed or touched together in a variety of robotic poses, with the constraint that any applied forces on each mating pair of load cells is equal and opposite.

Using the present method, the robot can self-calibrate its various load cells as needed without using an external calibration jig, as noted above. An external calibration jig is a structure of the type known in the art where strains are measured offline and compared to calibrated applied forces and torques. It may be difficult to calibrate a six-axis load cell mounted on or within a robot, but it is often necessary to do so, as over time load cell calibration can drift due to mechanical changes in the strain measuring structure of the load cell. This is especially true for miniature load cells. Therefore, in an anthropomorphic robot hand with fingers and an opposable thumb, the technique allows in-situ calibration of multiple load cells located in the fingertips/thumb tip and the proximal phalanges of the hand, at any time, simply by pressing or touching the load cells together and processing certain strain and joint angle measurements as set forth herein.

2

In particular, a robotic system includes a dexterous robot having a plurality of robotic joints, a plurality of angle sensors each measuring a joint angle value at a corresponding one of the robotic joints, a plurality of multi-axis load cells for measuring a strain value imparted to a corresponding one of the load cells during a predetermined pose of the robot, and a host machine. The host machine is electrically connected to each of the load cells and the angle sensors, and is configured to receive the joint angles from the angle sensors and the set of strain values from the load cells during the predetermined pose. The robot is adapted for pressing a selected pair of the load cells together during the predetermined pose. The host machine is adapted for processing the joint angles and the strain values to thereby determine a set of calibration matrices, and for determining a calibration matrix from the set of calibration matrices that is closest in a value to a pre-specified value, e.g., a value expected from an engineering analysis of the design of the load cells, a calibration matrix found in the most recent previous calibration run, etc.

The host machine includes a hardware module that is electrically connected to each of the load cells and to each of the angle sensors. The host machine is configured to receive the joint angles from the angle sensors and the strain values from the load cells during the predetermined pose, and includes an algorithm for calibrating the load cells using the joint angle values from the angle sensors and the strain values from the load cells.

The method for calibrating load cells in a dexterous robot having a plurality of robotic joints includes pressing together a mating pair of the load cells to form the predetermined pose, measuring the joint angles from the angle sensors and the strain values from the load cells during the predetermined pose, processing the joint angles and strain values via a host machine to thereby determine a set of calibration matrices, and determining a calibration matrix that is closest in a value to the pre-specified initial value noted above.

The above features and advantages and other features and advantages of the present invention are readily apparent from the following detailed description of the best modes for carrying out the invention when taken in connection with the accompanying drawings.

BRIEF DESCRIPTION OF THE DRAWINGS

FIG. 1 is a schematic perspective view illustration of a dexterous robot having multi-axis load cells that may be calibrated according to the method set forth herein;

FIG. 2 is a perspective view illustration of a lower robotic arm assembly of the robot shown in FIG. 1;

FIG. 3 is a schematic illustration of a controlled contact between a mating pair of multi-axis load cells; and

FIG. 4 is a flow chart describing a method for calibrating the multi-axis load cells of the robot shown in FIG. 1.

DESCRIPTION OF THE PREFERRED EMBODIMENT

With reference to the drawings, wherein like reference numbers refer to the same or similar components throughout the several views, and beginning with FIG. 1, a dexterous robot **10** is adapted to perform one or more automated tasks. The robot **10** is configured with independently and/or inter-dependently-moveable motor-driven robotic joints, such as but not limited to a shoulder joint, the position of which is generally indicated by arrow A. The robot **10** may also include an elbow joint (arrow B), a wrist joint (arrow C), a neck joint (arrow D), a waist joint (arrow E), and finger joints

(arrow F). Each of the joints includes one or more joint angle sensors **15** adapted for measuring joint angles (A), and for relaying these angular measurements to a host machine (HOST) **22** for processing via a sensor calibration algorithm **100** as explained below.

The robot **10** includes a lower arm assembly **25** having one or more anthropomorphic hands **12**. Each hand **12** includes an opposable thumb **14** and a plurality of fingers **16**, which together are capable of grasping an object **20** in the same hand, or in a cooperative grasp between different hands. Thumb **14** and each of the fingers **16** includes one or more multi-axis load cells **18** as described below, i.e., sensors each adapted for measuring one or more strain values (s) and for relaying the measurements to the host machine **22**.

Host machine **22** is electrically connected to the robot **10** and adapted, via execution of algorithm **100**, for calibrating the load cells **18** in-situ, i.e., while the load cells remain fully integrated within the architecture of the robot, and therefore without resorting to the use of an external calibration jig. The host machine **22** may include a hardware module **23** including single or multiple digital computers or data processing devices each having one or more microprocessors or central processing units (CPU), read only memory (ROM), and random access memory (RAM). Host machine **22** may also include sufficient amounts of erasable electrically-programmable read only memory (EEPROM), a high-speed clock, analog-to-digital (A/D) circuitry, digital-to-analog (D/A) circuitry, and any required input/output (I/O) circuitry and devices, as well as signal conditioning and buffer electronics. Individual algorithms resident in host machine **22** or readily accessible thereby, including algorithm **100**, may be automatically executed by the hardware module **23** as needed to provide the required functionality.

Referring to FIG. 2, the lower arm assembly **25** is shown in more detail to include a hand **12** with a thumb **14** and fingers **16**. The thumb **14** and fingers **16** are moveable alone or in combination via control elements **17** that may be embedded in the lower arm assembly **25** as shown. The hand **12** includes a base structure **34** that defines a palm **36**. The thumb **14** and fingers **16** are movably mounted to the base structure **34**, and are adapted to selectively curl toward the palm **36** in order to grip an object, e.g., the object **20** shown in FIG. 1. Thumb **14** and fingers **16** each include segments or phalanges **30** that are connected by joints (arrow F) and that are selectively powered via joint actuators such as motors, etc.

A multi-axis load cell **18** is connected to or integrated within each of the respective phalanges **30** of thumb **14** and fingers **16**. Load cells **18** are adapted to read and transmit strain data (s) to the host machine **22** of FIG. 1, wherein the strain data is processed to ultimately determine forces (f) as set forth below. While each load cell **18** should read at least one strain value, generally three strain values or more are measured to determine three force components. In one embodiment, each load cell **18** measures eight different strains simultaneously, although other strain value quantities may be used without departing from the intended scope of the present invention. While not shown for clarity, compact electronics may be provided within the hand **12** to power the various load cells **18**, e.g., collecting analog sensor data, converting analog signals to digital signals, multiplexing digital signals, and communicating the data as needed.

Referring to FIG. 3, a mating pair **40** of multi-axis load cells **18A**, **18B** is represented schematically. The mating pair **40** may be positioned in or on the fingertips of two fingers **16**, or on a tip of a finger and a thumb **14**, whether of a common hand **12** or of different hands. The load cells **18** may be self-calibrated by touching load cells **18A**, **18B** together in

different poses, and optionally to a calibrated load cell **18C** as noted below. As will be understood by those of ordinary skill in the art, a given load cell can be used to measure an applied force (f) by multiplying measured strains (s) by a linear transform or calibration matrix (K), i.e., $f=Ks$. This basic force equation is used by the host machine **22** in executing algorithm **100** to self-calibrate the load cells **18** used aboard robot **10** of FIG. 1.

Referring to FIG. 4, algorithm **100** is explained in conjunction with the schematic illustration of FIG. 3. As will be understood by those of ordinary skill in the art, a load cell is conventionally calibrated by extracting the load cell from its host robot and mounting the load cell in an external jig containing a calibrated reference load cell. Various forces and torques applied to the load cell to be calibrated are also measured by the calibrated load cell via the jig. A calibration matrix (K) for the load cell being calibrated is determined such that its force and torque outputs match the jig measurements as closely as possible. In a highly complex dexterous robot in which multiple load cells are fully and intricately integrated into the structure of the robot, the conventional external jig-based calibration technique may become highly impracticable.

Algorithm **100** is therefore executed via the host machine **22** to allow self-calibration of the various load cells **18** shown in FIGS. 1 and 2, doing so while the load cells remain in-situ. The algorithm **100** begins with step **102**, wherein selected load cells **18A**, **18B** shown in FIG. 3 are pressed or touched together in a series of different poses, e.g., poses **1** and **2**, to exert equal opposing forces W. In FIG. 3, f_1^b and f_2^b represent forces (f) applied by a digit B, i.e., a thumb **14** or a finger **16** of either hand **12**, having a load cell **18B** positioned in a first and second pose (**1** and **2**), respectively, while f_1^a and f_2^a respectively represent opposing forces applied by a load cell **18A** of an opposing digit B in the same poses.

It is assumed that forces on digit A are given by the formula: $f^a=Ks^a$. The value for sensor calibration matrix (K) for digit A is always the same, but different sensor readings from that digit A correspond to different forces applied to the same digit, i.e., a thumb **14** or finger **16** as noted above. After K is known, one may compute forces in digit A using readings from the sensors of that same digit, i.e., $f^a=Ks^a$. Additional external contacts may provide measurements that can be added to the sensor measurement set to improve the overall calibration results. For example, contact with a calibrated load cell, e.g., load cell **18C**, and/or a known weight provides a known force, and/or a low-friction surface of known orientation provides a force of unknown magnitude but known direction.

Beginning at step **102**, and with reference to the structure of robot **10** shown in FIG. 1, selected load cells **18A** and **18B** of FIG. 3 are pressed together by the robot in a first pose with equal and opposite force. The algorithm **100** then proceeds to step **104**.

At step **104**, for each pose the joint angles (A) and strains (s) are sensed, measured, or otherwise fully determined at the load cells **18A**, **18B** of the respective contacting digits A and B, i.e., the mating pair **40** shown in FIG. 3. The joint angles (A) are measured for each pose by joint sensors **15** at contacting load cells **18A** and **18B** of FIG. 3 so that their respective orientations can be determined in a common frame of reference. Load cell position and orientation are ultimately determined from these values via the host machine **22**. If the load cells of the mating pair **40** are positioned on different hands **12**, e.g., a left-hand finger touching a right-hand finger, all joint angles must be determined in the mechanical chain between the mating pair, that is, down one finger, through

5

both arms, and up the other finger, so that the common frame of reference, e.g., the torso, falls within the chain. Multiple mating pairs **40** can be included in the same sensor measurement set, along with the additional external contacts noted above in step **102**. Sensor readings s_i^a, s_i^b are therefore measured at a variety of orientations or poses R_i^a, R_i^b , where i =poses **1, 2, 3**, etc.

At step **106**, the host machine **22** solves a homogeneous set of equations for space of valid calibration matrices:

$$0 = \begin{pmatrix} f_1^a \\ f_2^a \\ \vdots \end{pmatrix} + \begin{pmatrix} f_1^b \\ f_2^b \\ \vdots \end{pmatrix} \\ = \begin{pmatrix} R_1^a K s_1^a \\ R_2^a K s_2^a \\ \vdots \end{pmatrix} + \begin{pmatrix} R_1^b J s_1^b \\ R_2^b J s_2^b \\ \vdots \end{pmatrix}$$

In these matrices, the variable J represents a calibration matrix for the opposing finger/thumb or digit B . Note that the R matrices are subscripted, indicating that these values change as the mating pair moves. Also note that the calibration matrices (K, J) appear linearly in this system of equations.

At step **106**, the host machine **22** characterizes all of the matrix pairs (K, J) that minimize the error in the force balance equations noted above. The minimizing set for a least-squares error criterion, by way of example, can be found using standard linear algebra, e.g., the singular-value decomposition or QR decomposition methods. All dimensions of the calibration matrices may not be fully determined, but the resultant calibration will be more accurate relative to the initial calibration.

At step **108**, the calibration matrix is found that is closest to an initial estimate. Among all error-minimizing pairs from step **106**, the pair (K, J) is selected that is closest to the initial estimate. Standard computational linear algebra applies if “closeness” is formulated in the least-squares sense according to the possible embodiment set forth above. The selected pair is then used to calibrate the load cells **18A, 18B** of the mating pair.

As noted above, calibration matrices (K, J) for the load cells **18A, 18B** may be determined up to an unknown scaling factor. The scaling factor may also be determined if at least one independent force measurement of known magnitude can be made, such as by supporting a known weight or by executing a single touch to a well-calibrated load cell, e.g., load cell **18C** in FIG. **3**. Even if only partial information can be extracted due to insufficiency in the relative poses of load cells **18A** and **18B**, this information can still be used to update and improve the pre-existing calibration.

For clarity of explanation, the examples set forth above describe a simplified two-digit pose. However, the scope of the present method is not limited to just two poses, and may involve touches between various load cells **18** on additional digits of the fingers. Calibration could involve a second finger, e.g., digit C (not shown), with digit A touching digit B multiple times before touching digit C multiple times. The calibration matrix for additional digit C may be represented as (H) . One may then calibrate set (K, J, H) as a triple of calibration matrices, and not just pair-wise, i.e., first for calibration set (K, J) , then for calibration set (K, H) . If these steps are performed pair-wise, different values for (K) may result, and one would then have to reconcile those differences to

6

obtain the best value of (K) . Therefore, for optimized performance all the balance equations may be combined into a single array, all the calibration matrices may be solved for simultaneously. In a similar manner, one could collect data for any number of pair-wise touches for as many load cells **18** as there are on the various thumbs **14** and/or fingers **16** and their several phalanges **30**.

While the best modes for carrying out the invention have been described in detail, those familiar with the art to which this invention relates will recognize various alternative designs and embodiments for practicing the invention within the scope of the appended claims.

The invention claimed is:

1. A robotic system comprising:

- a dexterous robot having a plurality of robotic joints;
- a plurality of angle sensors each adapted for measuring a joint angle value at a corresponding one of the robotic joints;
- a plurality of load cells each adapted for measuring at least one strain value imparted to a corresponding one of the load cells during a predetermined pose of the robot; and
- a host machine that is electrically connected to each of the load cells and to each of the angle sensors, the host machine being configured to receive the joint angles from the angle sensors and the at least one strain value from each of the load cells during the predetermined pose;

wherein the robot is adapted for pressing a mating pair of the load cells together to form the predetermined pose, and wherein the host machine is adapted for processing the joint angles and the strain values to thereby determine a set of calibration matrices, and for determining a calibration matrix from the set of calibration matrices that is closest in a value to a pre-specified value.

2. The robotic system of claim **1**, further comprising an anthropomorphic robotic hand having an opposable thumb and a plurality of fingers, wherein at least one of the load cells are disposed on the thumb and on each of the fingers.

3. The robotic system of claim **1**, wherein the host machine is adapted for minimizing an error in a set of force-balance equations by calculating the set of calibration matrices for each of the load cells of the mating pair.

4. The robotic system of claim **3**, wherein the host machine minimizes the error using a least-squares technique.

5. The robotic system of claim **1**, wherein the host machine is adapted for determining a common frame of reference for the mating pair using the joint angles corresponding to the mating pair.

6. The robotic system of claim **1**, wherein the robot is adapted for executing different predetermined poses in succession, and wherein the host machine is adapted for calculating the calibration matrix for each mating load cell pair used in the different predetermined poses.

7. The robotic system of claim **6**, including a pre-calibrated load cell separate from the plurality of load cells, wherein the robot is adapted for touching one of the load cells to the pre-calibrated load cell to form one of the different predetermined poses.

8. A host machine adapted for use within a robotic system, the robotic system including a dexterous robot having a plurality of robotic joints, a plurality of angle sensors each adapted for measuring a joint angle value at a corresponding one of the robotic joints, and a plurality of load cells each adapted for measuring a set of strain values during a predetermined pose of the robot, the robot being adapted for pressing a mating pair of the load cells together to form the predetermined pose, the host machine comprising:

7

a hardware module that is electrically connected to each of the load cells and to each of the angle sensors, and configured to receive the joint angles from the angle sensors and the strain values from the load cells during the predetermined pose; and

an algorithm for calibrating the load cells using the joint angle values from the angle sensors and the strain values from the load cells, wherein the algorithm is adapted for: measuring the joint angles from the angle sensors and the strain values from the load cells during the predetermined pose, processing the joint angle and the strain values via a host machine to thereby determine a set of calibration matrices; and

determining a calibration matrix from the set of calibration matrices that is closest in a value to a pre-specified value.

9. The host machine of claim 8, wherein the host machine is adapted for minimizing an error in a set of force-balance equations by calculating a pair of calibration matrices for each of the load cells of the mating pair.

10. The host machine of claim 9, wherein the host machine minimizes the error using a least-squares technique.

11. The host machine of claim 8, wherein the host machine is adapted for determining a common frame of reference for the mating pair using the joint angles corresponding to the mating pair.

12. The host machine of claim 8, wherein the robot is adapted for executing different predetermined poses in succession, and wherein the host machine is adapted for calculating a calibration matrix for each mating load cell pair used in the different predetermined poses.

13. A method for calibrating load cells in a dexterous robot having a plurality of robotic joints, a plurality of angle sensors

8

each adapted for measuring a joint angle value at a corresponding one of the robotic joints, a plurality of load cells each adapted for measuring a set of strain values imparted to a corresponding one of the load cells during a predetermined pose of the robot, the method comprising:

pressing together a mating pair of the load cells to form the predetermined pose;

measuring the joint angles from the angle sensors and the strain values from the load cells during the predetermined pose;

processing the joint angle and the strain values via a host machine to thereby determine a set of calibration matrices; and

determining a calibration matrix from the set of calibration matrices that is closest in a value to a pre-specified value.

14. The method of claim 13, wherein the robot includes a finger and a thumb each having one of the load cells, and wherein pressing together a mating pair of the load cells includes pressing together the respective load cells of the finger and thumb.

15. The method of claim 13, further comprising: minimizing an error in a set of force-balance equations by calculating the set of calibration matrices for each of the load cells of the mating pair.

16. The method of claim 13, further comprising: determining a common frame of reference for the mating pair using the joint angles corresponding to the mating pair.

17. The method of claim 13, further comprising: executing different predetermined poses in succession; and calculating the calibration matrix for each mating load cell pair used in the different predetermined poses.

* * * * *