



US008225984B1

(12) **United States Patent
Ding**

(10) **Patent No.: US 8,225,984 B1**
(45) **Date of Patent: Jul. 24, 2012**

(54) **THERMAL STIR WELDING PROCESS**

(56) **References Cited**

(75) Inventor: **R. Jeffrey Ding**, Athens, AL (US)

U.S. PATENT DOCUMENTS

(73) Assignee: **The United States of America as represented by the Administrator of the National Aeronautics and Space Administration**, Washington, DC (US)

6,068,178 A * 5/2000 Michisaka 228/122.1
6,637,642 B1 * 10/2003 Lingnau 228/122.1
6,986,452 B2 * 1/2006 Dracup et al. 228/112.1
7,028,880 B2 * 4/2006 Narita et al. 228/112.1
7,210,610 B2 * 5/2007 Nelson et 228/2.1

(*) Notice: Subject to any disclaimer, the term of this patent is extended or adjusted under 35 U.S.C. 154(b) by 0 days.

FOREIGN PATENT DOCUMENTS
JP 2000343250 A * 12/2000
WO 9845080 A1 10/1998
WO WO 9932254 A1 * 7/1999
WO WO 9939861 A1 * 8/1999

(21) Appl. No.: **13/157,988**

* cited by examiner

(22) Filed: **Jun. 10, 2011**

Primary Examiner — Jessica L Ward

Assistant Examiner — Devang R Patel

Related U.S. Application Data

(74) *Attorney, Agent, or Firm* — Douglas E. Jackson; James J. McGroary

(60) Continuation of application No. 10/385,168, filed on Feb. 28, 2003, now Pat. No. 7,980,449, which is a division of application No. 09/994,506, filed on Nov. 27, 2001, now abandoned.

(51) **Int. Cl.**
B23K 20/12 (2006.01)
B23K 37/00 (2006.01)

(52) **U.S. Cl.** **228/112.1**; 228/2.1; 228/2.3; 228/227; 228/230; 228/232; 219/75; 219/121.64; 219/121.76

(58) **Field of Classification Search** 228/2.3, 228/2.1, 112.1, 230, 232, 227; 219/75, 121.64, 219/121.76

See application file for complete search history.

(57) **ABSTRACT**

A welding method is provided for forming a weld joint between first and second elements of a workpiece. The method includes heating the first and second elements to form an interface of material in a plasticized or melted state interface between the elements. The interface material is then allowed to cool to a plasticized state if previously in a melted state. The interface material, while in the plasticized state, is then mixed, for example, using a grinding/extruding process, to remove any dendritic-type weld microstructures introduced into the interface material during the heating process.

24 Claims, 1 Drawing Sheet

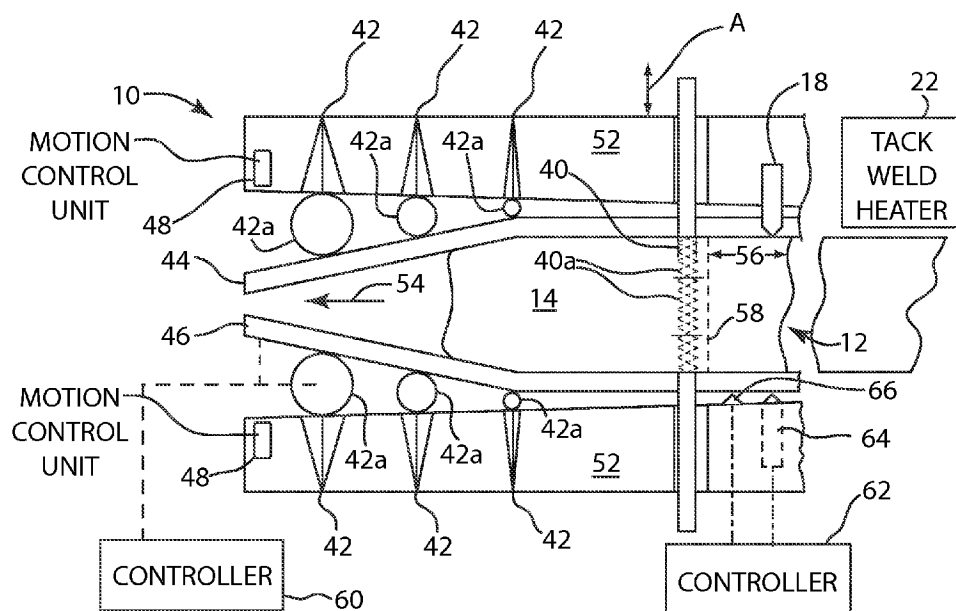

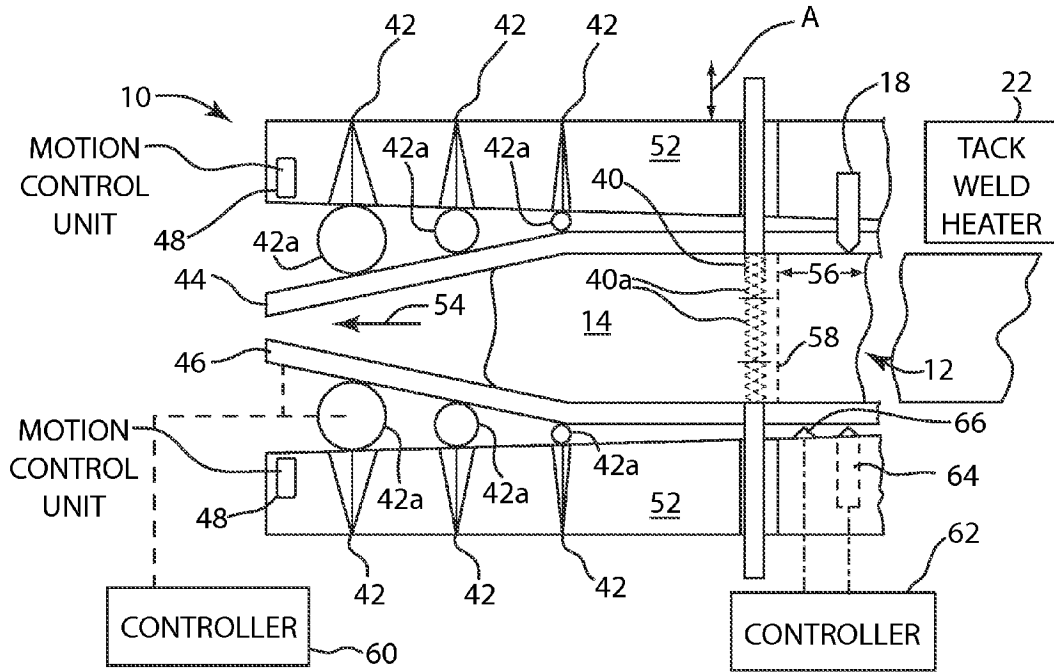

FIG. 1

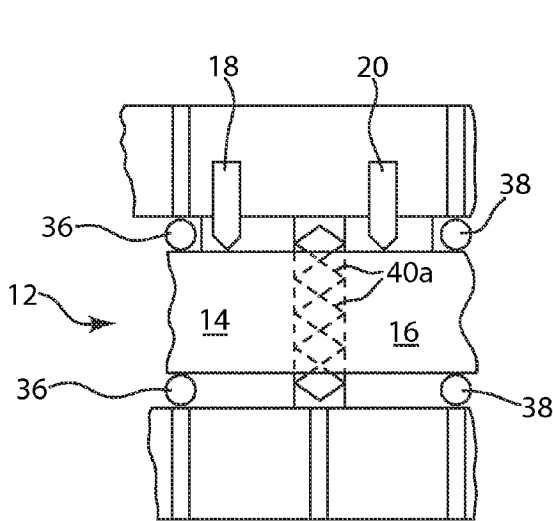

FIG. 2

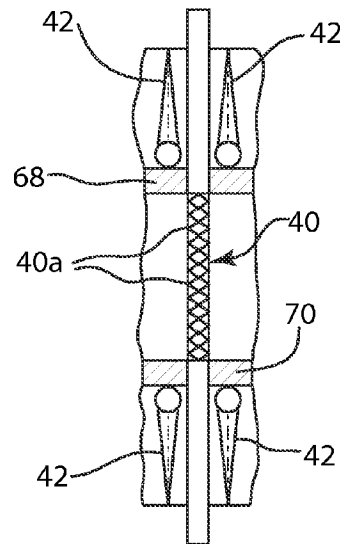

FIG. 3

1

THERMAL STIR WELDING PROCESS**CROSS REFERENCE TO RELATED APPLICATION**

This application is a continuation of application Ser. No. 10/385,168, filed Feb. 28, 2003 now U.S. Pat. No. 7,980,449 (which is hereby incorporated by reference); which is a divisional of application Ser. No. 09/994,506 filed on Nov. 27, 2001 (now abandoned).

ORIGIN OF THE INVENTION

This invention was made by employees of the United States Government and may be manufactured and used by or for the Government for governmental purposes without the payment of any royalties.

BACKGROUND OF THE INVENTION**1. Field of the Invention**

The present invention relates to a welding method and apparatus, and in particular, to a welding method and apparatus which separately plasticizes or melts the surfaces to be joined followed by a subsequent weld matrix mixing process.

2. Background of the Invention

Welding processes can be classified into one of two categories, fusion welding and solid state welding. Fusion welding involves melting material to be welded and includes such processes as MIG, TIG and VPPA welding. Solid state welding joins materials without a melting step and include the processes of friction stir and inertia welding. Fusion weld processes typically result in a dendritic type weld microstructure exhibiting inferior mechanical and structural properties. Such inferior material properties are generally seen in metals subsequent to melting. Conversely, solid state weld processes result in a non-dendritic grain structure exhibiting properties superior to those produced with fusion welding processes.

Both fusion welding and solid state welding have respective limitations. As indicated above, fusion welding compromises the microstructure of the material and thus lessens the physical properties and characteristics of the material. Solid state welding such as inertia welding is limited to rounded structures such as pipe or rod structures.

A recent advancement was made when friction stir welding became available for the solid state welding of materials. Reference is made, for example, to U.S. Pat. Nos. 6,168,067 B1 to Waldron et al. and 6,053,391 to Heideman et al. With the use of friction stir welding, a solid state weld could, for the first time, be provided in applications requiring longitudinal welds, ranging from several inches to an unlimited length. As described in more detail in the aforementioned patents, the friction stir weld process uses a rotating shoulder/pin configuration. The shoulder produces frictional heat to bring the material into a plasticized state and forges the welded material with extremely large forces. To accomplish the necessary large forces for the forging effect, a very robust backing anvil is required for support. The welding pin spins inside the workpiece at the same rate as the shoulder. The dependent motion of the welding pin and shoulder restricts the speed of the welding process.

BRIEF SUMMARY OF THE INVENTION

In accordance with the present invention, a welding method and apparatus are provided for forming a weld joint. The method separates the welding process into separate and

2

discrete steps, one providing heating of first and second abutting elements to be welded to form an interface therebetween of plasticized or melted material and a further matrix transformation step for processing the interface material after cooling to a plasticized phase. The heating process may use any conventional fusion welding process such as laser or plasma torch which initially melts the interface material. Subsequently, a separate grinding/extrusion element recrystallizes possible, undesirable dendritic matrix structures while the interface material is in the plasticized temperature state. Advantageously, separate heating sources can be used to plasticize or melt the respective first and second elements forming the weld joint independently. The independent melting feature provides for the joining of dissimilar metals such as copper and aluminum or stainless steel and titanium.

According to one aspect of the present invention, a welding method is provided for joining a workpiece comprising first and second elements in abutting relation along facing surfaces. The method includes heating the first and second elements to plasticize or melt the elements at least at the facing surfaces so as to form an interface therebetween of material in a melted state. If the interface material is heated to a melted state, then the interface material is allowed to cool from the melted state to a plasticized state. Next, the interface material is mixed while in the plasticized state.

According to another aspect of the present invention, an apparatus is provided for forming a weld joint in a workpiece between first and second elements in abutting relation along facing surfaces. The apparatus includes a heating device for plasticizing or melting the first and second elements at least at the facing surfaces so as to form interface therebetween of material in a plasticized or melted state respectively. A mixing tool mixes the interface material when in a plasticized state.

Preferably, the apparatus further comprises forming means for exerting force on the elements to control forming thereof. Advantageously, the temperature of the forming means is controlled to provide heating or cooling of the elements.

In one preferred embodiment, the forming means comprises at least one forging plate. Advantageously, the apparatus further comprises control means for sensing the force exerted by the forging plate and for controlling feeding of the first and second elements based thereon. Preferably, the control means controls one of feed rate and travel speed to control feeding of the elements.

In another preferred embodiment, the forming means comprises a plurality of rollers. In this embodiment, the apparatus preferably further comprises control means for controlling the force exerted by the rollers and for controlling feeding of the first and second elements based thereon. Preferably, the control means controls one of feed rate and travel speed to control feeding of said elements.

Preferably, the apparatus further comprises control means for sensing energy input to the heating elements and for controlling one of feed rate or travel speed of the elements based thereon.

In a preferred implementation, the apparatus further comprises a pre-weld tack welding means located upstream of the mixing tool for tack welding the two elements together prior to mixing by the mixing tool.

Advantageously, the mixing tool is retractable so as to enable complete withdrawal thereof from the first and second elements.

Preferably, the apparatus further comprises containment forging plates for containing the first and second elements during mixing by the mixing tool.

According to yet another aspect of the present invention, a joined workpiece has a first element comprising a first metal

3

material having a first plasticized temperature and a second element comprising a second metal material having a second plasticized temperature different from the first plasticized temperature. A longitudinal weld joint is formed between the first metal element and the second metal element. The weld joint has a recrystallized fine grain matrix.

A key feature of the present invention relates to the separation of a heating process to form a plasticized or melted interface material between two elements to be joined and a mixing process for mixing the interface material together while in a plasticized state. This separation enables each of the respective materials being joined to be heated and plasticized/melted independently. One advantage of this feature is that the invention enables dissimilar metals to be welded together which previously were not able to be joined, i.e., metals such as copper/aluminum, stainless steel/copper, and stainless steel/titanium. For example, a copper/aluminum weld can be achieved by providing independent temperature control as each alloy is brought up to its respective plasticized/melted state. A further advantage of separating the heating process from the weld matrix transformation process is that comparatively high workpiece travel rates during welding can be obtained. In this regard, the present invention is not inherently limited with respect to travel rates as is the case with a friction stir welding process.

An additional important feature of the present invention is that the invention provides matrix transformation of the interface material from dendritic to fine grained material. More specifically, the present invention provides for transforming grain structure from the dendritic-type weld microstructure formed as a result of the heating process to a recrystallized fine, non-dendritic grain structure. As a consequence, the resulting final grain structure is typically that of a solid state weld material and thus exhibits excellent mechanical material properties.

A further advantage of the present invention is that the invention can provide long longitudinal welds of varying material thickness.

Yet another advantage of the present invention is that the invention can be used to form longitudinal welds exhibiting a solid state weld material property without a backing anvil such as is required in stir welding.

Further features and advantages of the present invention will be set forth in, or apparent from, the detailed description of preferred embodiments thereof which follows.

BRIEF DESCRIPTION OF THE DRAWING

FIG. 1 is a longitudinal cross sectional view of a welding apparatus according to a preferred embodiment of the present invention;

FIG. 2 is an end elevational view of the welding apparatus of FIG. 1; and

FIG. 3 is a longitudinal cross sectional view, partially broken away, of a further embodiment of the invention.

DETAILED DESCRIPTION OF THE INVENTION

Referring now to FIG. 1 and FIG. 2, there is shown a welding device, generally denoted 10, which is adapted to join together first and second elements 14 and 16 of a workpiece 12. The welding device 10 includes heating elements 18 and 20.

Heating element 18 provides sufficient heat to plasticize or melt the material of element 14 and may comprise such conventional heating devices as lasers or plasma torches or other suitable devices known in the art. Similarly, heating element

4

20 provides sufficient heat to plasticize or melt the material of element 16. As a result, together, heating elements 18 and 20 transform a portion of the solid material of the workpiece 12, viz., respective abutting portions of elements 14, 16 to form an interface 34 (see FIG. 2) in a plasticized or melted phase, between the elements 14, 16.

The heating elements 18 and 20 can be controlled individually for providing heating at a desired separate temperature. For example, where elements 14 and 16 comprise dissimilar materials having different melting points, heating element 18, preferably provides heating at the plasticizing or melting temperature of element 14 whereas heating element 20 preferably provides heating at the plasticizing or melting temperature of the material of element 16.

The material of element 14 and element 16 may be formed of the same or different metal material. For example, element 14 may be copper or stainless steel, and element 16 may be aluminum, copper or titanium, so that when joined together, elements 14 and 16 form a workpiece 12 formed of copper/aluminum, or stainless steel/copper or stainless steel/titanium or another combination.

In an alternative embodiment, additional heating elements (not shown) of the type of heating elements 18, 20 may be disposed adjacent to the heating elements 18, 20 and/or below workpiece 12, to assist in plasticizing/melting the abutting portions of the elements 14, 16. An optional tack weld heater 22, disposed upstream, relative to the heaters 18 and 20, provides sufficient heat to form an initial tack weld between the elements 14, 16.

As shown in FIG. 2, a pair of clamping elements 36, 38 apply a respective force on the workpiece 12 towards each other. The force applied maintains elements 14 and 16 in proper alignment with each other.

A mixing tool such as toothed grinding/extruding member 40 is positioned in the path of the interface 34 between elements 14 and 16 and rotates to mix the material of interface 34 when in a plasticized phase. The grinding/extruding member 40 allows plasticized metal of the interface 34 to flow and extrude through the individual teeth, which are indicated at 40a, of member 40. The teeth 40a are angled, thus forcing the plasticized material to flow downwards or upwards depending upon the angle of the teeth 40a. As a result, the grinding/extruding member 40 will recrystallize the dendritic matrix structure which may have been formed in the material of interface 34 as a result of the melting process. Grinding/extruding member 40 is retractable as indicated by arrow A and can be completely withdrawn from the workpiece formed by elements 14 and 16.

A plurality of force actuators 42 are located downstream of grinding member 40 and used to apply a force on a pair of forging plates 44, 46 which are located on opposite sides of workpiece 12. Force actuators 42 include rollers 42a which engage and bear against plates 44, 46. In an alternative embodiment, plates 44, 46 can be eliminated and rollers 42a used to bear directly on the workpiece, i.e., either rollers, or plates, can be used separately to exert the required force to further form the workpiece. Further, the rollers or forging plates can be heated or cooled (e.g., by water cooling) to control the temperature of the workpiece material.

As indicated in the drawings, the heating elements described above and the grinding member 40 extend through forging plates 44, 46 so as to permit them to perform their respective functions. The force exerted upon the forging plates 44, 46 by the force actuators 42 is constant for a workpiece having constant thickness, while a variable force is exerted on the forging plates 44, 46 by the actuators 42 to accommodate workpieces of a tapered thickness.

5

A pair of motion control devices indicated separately at **48** control the amount of movement of the forging plates **44**, **46**. The motion control devices **48** each may comprise a LVDT, a laser device or other suitable motion control device known in the art.

During the operation of the welding device **10**, the workpiece **12** is inserted into an entrance **50** of a housing **52** which houses the various elements and units described above. As set forth hereinbefore, the heating elements **18**, **20** provide the desired heating of elements **14** and **16**, to form the plasticized or melted phase interface **34**.

During the heating process, undesirable dendritic-type weld microstructures may be introduced into the matrix of the interface material **34**. Advantageously, the heating process takes place in an inert environment. For example, nitrogen gas can be pumped into housing **52** to provide an inert environment, thereby reducing or eliminating the oxidation of the material of workpiece **12** during the heating process.

The workpiece **12** proceeds through the welding device **10** in a direction denoted by arrow **54**. The material of interface **34** is in a plasticized or melted state while in the area generally indicated by reference numeral **56**. As the workpiece **12** proceeds along direction **54**, if the interface was heated to a melted state, the melted interface is transformed into a plasticized state. The transition point where the melted interface becomes plasticized is denoted by a dashed line **58**. The workpiece **12** transitions from the melted state to the plasticized state due to the absence of applied heat. Alternatively, if the material of interface **34** is merely heated to a plasticized state, the interface material remains in a plasticized state as the workpiece proceeds past dashed line **58**.

The workpiece **12** then proceeds to the location the grinding/extruding member **40**. The interface **34**, now in the plasticized state, is processed by the grinding/extruding teeth **40a** of member **40** and the plasticized material of interface **34** flows and is extruded through the teeth **40a**. As indicated above, this processing of the interface material dramatically recrystallizes the grain structure, thus producing a fine grained weld matrix when fully cooled.

As shown in the drawings, member **40** includes a central mixing portion comprising the grinding/extruding teeth **40a** extending along the length thereof and support portions directly connected to the central portion. Considering, for example, the upper support portion, this portion extends through an opening in forging plate **44** which terminates at a major surface at plate **44**, as illustrated.

The workpiece **12** next travels past the grinding/extruding member **40** to a location where the hot interface material, which is still in a plasticized state, is forged under pressure by the forging plates **44**, **46**.

In an advantageous embodiment, a controller or control system **60** is employed which controls the feed rate or travel speed of the workpiece formed by elements **14** and **16** by controlling the force exerted by either the forging plates **44**, **46** and/or rollers **42a** (whether used separately or in combination, as indicated schematically by the dashed lines in FIG. 1). Although a separate controller **60** is shown, the control system could directly control force actuators **42**.

Alternatively, or in addition, a control system or controller **62** is also provided which controls the material feed rate or travel speed by monitoring or sensing the energy input to the heating elements **18** and **20**, or as illustrated, the energy input to a further heating element **64**. The overall control system could also include a sensor **66** for sensing feed rate or travel speed and supplying a corresponding input signal to controller **62**.

6

Referring to FIG. 3, in accordance with a further important feature of the invention, separate containment forging plates **68** and **70** are provided closely adjacent to or, in one embodiment, in surrounding relation to, the mixing tool **40** so as to contain the heated material of elements **14**, **16** during rotation of the grinding teeth **40a** of mixing tool **40**.

It should be apparent to those of ordinary skill that the present device and process offers important advantages over previous welding methods. These advantages include the ability to weld together dissimilar alloys which previously could not be joined due to differences in their respective melted and plasticized phase temperatures. Further, the separation of the plasticizing/melting process and interface matrix transformation process results in significantly enhanced welding speeds.

Although the invention has been described above in relation to preferred embodiments thereof, it will be understood by those skilled in the art that variations and modifications can be effected in these preferred embodiments without departing from the scope and spirit of the invention.

What is claimed is:

1. A method of forming a weld joint between a first longitudinal element and a second longitudinal element where the first and second longitudinal elements are made of dissimilar materials, said method comprising the steps of:

moving the first and second longitudinal elements longitudinally relative to a support assembly, said moving step including the step of abutting the first and second longitudinal elements along laterally opposed first and second facing edge surfaces of the dissimilar materials;

plasticizing a continuous longitudinal interface between the opposed first and second facing edge surfaces of the dissimilar materials, said plasticizing step including the step of heating the opposed first and second facing edge surfaces of the dissimilar materials to a plasticizing temperature as the first and second longitudinal elements are longitudinally moved longitudinally relative to the support assembly;

mixing, with an elongate mixing tool extending into the plasticized dissimilar materials of the first and second facing edge surfaces, the dissimilar plasticized materials of the first and second facing edge surfaces as the first and second longitudinal elements are moved relative to the support assembly whereby a longitudinal weld joint of the dissimilar materials of the opposed first and second facing edge surfaces is formed downstream from the mixing tool; and

forging, with first and second containment forging elements provided on the support assembly downstream of the mixing tool and positioned on first and second sides of the first and second longitudinal elements, the first and second longitudinal elements as the first and second longitudinal elements are longitudinally moved between and relative to the forging elements, said forging step including the step of containing the moving first and second longitudinal elements during mixing of the dissimilar materials of the first and second facing edge surfaces by the mixing tool.

2. A method of forming a weld joint as claimed in claim 1, wherein said mixing step includes the steps of grinding and extruding of the dissimilar materials of the first and second facing edge surfaces with said mixing tool.

7

3. A method of forming a weld joint as claimed in claim 1, wherein said heating step includes the steps of:

heating, with a first heat source, the first facing edge surface of the first longitudinal element to a plasticizing temperature of the first material of the first longitudinal element; and

heating, with a second heat source separate from the first heat source, the second facing edge surface of the second longitudinal element to a plasticizing temperature of the second material of the second longitudinal element which is different from the plasticizing temperature of the first material.

4. A method of forming a weld joint as claimed in claim 1, wherein said forging step includes the step of controlling a temperature of each of the first and second containment forging elements to provide heating or cooling of the longitudinal elements.

5. A method of forming a weld joint as claimed in claim 1, wherein said forging step includes the steps of:

sensing a force exerted by at least one of the forging elements; and

controlling a feeding of the first and second longitudinal elements based on the sensed force.

6. A method of forming a weld joint as claimed in claim 1, wherein said forging step includes the step of applying a controlled force to at least one of the forging elements.

7. A method of forming a weld joint as claimed in claim 6, wherein said applying step applies the controlled force through a plurality of rollers.

8. A method of forming a weld joint as claimed in claim 7, wherein said applying step further includes the steps of controlling the force applied by the plurality of rollers, and controlling a feeding of the first and second longitudinal elements based on the controlled force applied.

9. A method of forming a weld joint as claimed in claim 8, wherein said controlling step also controls one of feed rate and travel speed to control feeding of the first and second longitudinal elements.

10. A method of forming a weld joint as claimed in claim 1, wherein said heating step includes the steps of:

sensing an energy input to a heating device; and controlling one of a feed rate or a travel speed of the first and second longitudinal elements based on the sensed energy input.

11. A method of forming a weld joint as claimed in claim 1, further including the step of tack welding the first and second longitudinal elements together prior to said plasticizing and mixing steps.

12. A method of forming a weld joint as claimed in claim 1, wherein said plasticizing step includes the step of creating dendritic-type weld microstructures in the opposed first and second facing edge surfaces; and

wherein said mixing step includes the step of recrystallizing the dendritic-type weld microstructures in the opposed first and second facing edge surfaces.

13. A method of forming a weld joint as claimed in claim 1, further including the step of providing an inert environment where said plasticizing and mixing steps take place.

14. A method of forming a weld joint between a first longitudinal element and a second longitudinal element where the first and second longitudinal elements are made of dissimilar materials, said method comprising the steps of:

moving the first and second longitudinal elements longitudinally relative to a support assembly, said moving step including the step of abutting the first and second longitudinal elements along laterally opposed first and second facing edge surfaces of the dissimilar materials;

8

plasticizing a continuous longitudinal interface between the opposed first and second facing edge surfaces of the dissimilar materials, said plasticizing step including the steps of

heating the opposed first and second facing edge surfaces of the dissimilar materials to a plasticizing temperature as the first and second longitudinal elements are longitudinally moved longitudinally relative to the support assembly and

creating dendritic-type weld microstructures in the opposed first and second facing edge surfaces;

mixing, with an elongate mixing tool extending into the plasticized dissimilar materials of the first and second facing edge surfaces, the dissimilar plasticized materials of the first and second facing edge surfaces as the first and second longitudinal elements are moved relative to the support assembly whereby a longitudinal weld joint of the dissimilar materials of the opposed first and second facing edge surfaces is formed downstream from the mixing tool, said mixing step including the step of recrystallizing the dendritic-type weld microstructures in the opposed first and second facing edge surfaces; and

forging, with first and second containment forging elements provided on the support assembly downstream of the mixing tool and positioned on first and second sides of the first and second longitudinal elements, the first and second longitudinal elements as the first and second longitudinal elements are longitudinally moved between and relative to the forging elements, said forging step including the step of containing the moving first and second longitudinal elements during mixing of the dissimilar materials of the first and second facing edge surfaces by the mixing tool.

15. A method of forming a weld joint as claimed in claim 14, wherein said mixing step includes the steps of grinding and extruding of the dissimilar materials of the first and second facing edge surfaces with said mixing tool.

16. A method of forming a weld joint as claimed in claim 14, wherein said heating step includes the steps of:

heating, with a first heat source, the first facing edge surface of the first longitudinal element to a plasticizing temperature of the first material of the first longitudinal element; and

heating, with a second heat source separate from the first heat source, the second facing edge surface of the second longitudinal element to a plasticizing temperature of the second material of the second longitudinal element which is different from the plasticizing temperature of the first material.

17. A method of forming a weld joint as claimed in claim 14, wherein said forging step includes the step of controlling a temperature of each of the first and second containment forging elements to provide heating or cooling of the longitudinal elements.

18. A method of forming a weld joint as claimed in claim 14, wherein said forging step includes the steps of:

sensing a force exerted by at least one of the forging elements; and

controlling a feeding of the first and second longitudinal elements based on the sensed force.

19. A method of forming a weld joint as claimed in claim 14, wherein said forging step includes the step of applying a controlled force to at least one of the forging elements.

9

20. A method of forming a weld joint as claimed in claim 19, wherein said applying step applies the controlled force through a plurality of rollers.

21. A method of forming a weld joint as claimed in claim 20, wherein said applying step further includes the steps of controlling the force applied by the plurality of rollers, and controlling a feeding of the first and second longitudinal elements based on the controlled force applied.

22. A method of forming a weld joint as claimed in claim 21, wherein said controlling step also controls one of feed rate and travel speed to control feeding of the first and second longitudinal elements.

10

23. A method of forming a weld joint as claimed in claim 14, wherein said heating step includes the steps of: sensing an energy input to a heating device; and controlling one of a feed rate or a travel speed of the first and second longitudinal elements based on the sensed energy input.

24. A method of forming a weld joint as claimed in claim 14, further including the step of tack welding the first and second longitudinal elements together prior to said plasticizing and mixing steps.

* * * * *