

A 2-MICRON PULSED INTEGRATED PATH DIFFERENTIAL ABSORPTION LIDAR DEVELOPMENT FOR ATMOSPHERIC CO₂ CONCENTRATION MEASUREMENTS

Jirong Yu¹, Mulugeta Petros¹, Karl Reithmaier², Yingxin Bai², Bo C Trieu¹, Tamer F. Refaat³,
Michael J. Kavaya¹, Upendra N Singh¹

¹NASA Langley Research Center, MS 468, Hampton, VA 23681 USA, j.yu@nasa.gov

²Science System & Applications, Inc, One Enterprise Parkway, Hampton, Virginia 23666 USA

³Old Dominion University, Applied Research Center, Newport News, VA 23606 USA

ABSTRACT

A 2-micron pulsed, Integrated Path Differential Absorption (IPDA) lidar instrument for ground and airborne atmospheric CO₂ concentration measurements via direct detection method is being developed at NASA Langley Research Center. This instrument will provide an alternate approach to measure atmospheric CO₂ concentrations with significant advantages. A high energy pulsed approach provides high-precision measurement capability by having high signal-to-noise level and unambiguously eliminates the contamination from aerosols and clouds that can bias the IPDA measurement.

1. INTRODUCTION

Active sensing of CO₂ concentrations will dramatically increase the understanding of CO₂ sources, sinks, and fluxes worldwide [1]. The mid-IR wavelength regions at 1.57 μ m and 2.05 μ m are considered suitable for atmospheric CO₂ measurements. Two instruments operating at 1.57 μ m have been developed and deployed as airborne systems for atmospheric CO₂ column measurements [2, 3]. One instrument is based on an intensity modulated continue wave (CW) approach, the other on a high pulse repetition frequency (PRF), low pulse-energy approach. These airborne CO₂ lidar systems operating at 1.57 μ m utilize mature laser and detector technologies by taking advantage of the technology development outcomes in the telecom industry. On the other hand, lidars operating in the 2 μ m band offer better near-surface CO₂ measurement sensitivity due to the intrinsically stronger absorption lines. We have chosen to operate the lidar on the long wavelength wing of R(30) CO₂ line at 2050.967 nm (4875.749 cm⁻¹) in the side-line operation mode. The R(30) line is an excellent absorption line for the measurements of CO₂ in 2 μ m wavelength region with regard to the strength of the absorption lines, low susceptibility to atmospheric temperature variability, and freedom from problematic interference with other absorption lines [4-6]. The sensitivity and low detection limit of an IPDA lidar for a specific molecule are defined by the differential absorption cross section between the on- and off-line. The computations of differential absorption cross-section will take advantage

of the most recent full range of spectroscopic measurements including pressure shifts and pressure dependence of line shape [7]. The pulsed lidar approach inherently provides a means for determining range across the scattering targets. The reflected signals can be resolved between aerosols, clouds, and topographical surfaces. It can directly eliminate contamination from aerosols and clouds to yield high accuracy measurements for CO₂ IPDA column measurements. This paper describes the development of a 2-micron pulsed IPDA lidar instrument that will measure atmospheric CO₂ concentration from ground and airborne platform.

2. DESCRIPTION OF THE IPDAHARDWARE

High-precision and accurate atmospheric CO₂ measurement impose stringent requirements on the lidar transmitter and receiver parameters, such as laser energy, pulse repetition rate, laser frequency control accuracy, telescope design and aperture size, high sensitivity with low noise detector and receiver design [8]. Figure 1 depicts the block diagram for the 2-micron pulsed IPDA instrument.

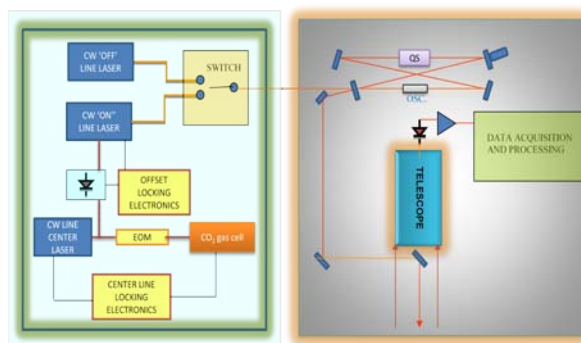

Figure1 CO₂ IPDA instrument block diagram

2.1 Wavelength Control Unit

The left side block in Figure 1 is a wavelength control and switch unit. The on-off line frequency accuracy and stability of the IPDA lidar are critical for making precise and accurate CO₂ measurements. To achieve the frequency accuracy and stability requirements of the pulsed lidar system, the technique of injection seeding

is used in which the excellent single frequency and single mode characteristics of low power, spectrally pure continue wave (CW) lasers are imposed upon the pulsed laser. We have developed a technology for establishing wavelength knowledge to well under 0.05 pm (3.75 MHz). Furthermore, a capability has been added to tune and lock anywhere on the side of the absorption line, so that a desired measurement range and accuracy of the IPDA instrument can be optimized. Tailoring the level of absorption further improves precision and accuracy of the IPDA results.

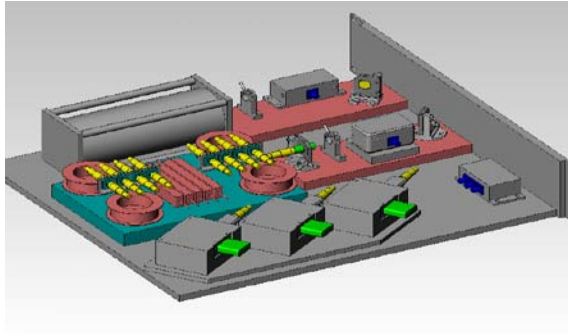

Figure 2. Design of engineering package of the wavelength control unit

To obtain the unprecedented wavelength accuracy and stability, a master wavelength reference against a sample of CO₂ in a gas cell is established. One of the CW lasers, called the center-line reference, is passed through the gas cell and actively locked by a frequency modulation spectroscopic technique to hold the laser with respect to absorption line center [9]. Tests have shown that long term stabilization over many hours to absorption line center is made to 370 kHz (0.005 pm) standard deviation. A second laser, called the tunable side-line, is referenced to the center-line laser by a heterodyne technique. By monitoring the heterodyne beat signal between the two lasers, the amount of detuning from line center can be determined with high accuracy. The detuning range between the two lasers can be set anywhere from a few hundreds of MHz to larger than 6 GHz. An electronic control loop locks the side-line laser at a programmed offset from line center. The side-line laser detuned from the center-line by 4 GHz has been shown to hold the lock to within 322 kHz (0.004 pm) over many hours. The capability of the frequency detuning and locking allows the optimization of the optical depth for measuring atmospheric CO₂ concentrations. A third CW laser provides the off-line wavelength and does not need to be actively controlled because its wavelength is known to be well away from an absorption line. However, it can be locked relative

to the reference laser using the same technology as the side line locking if it becomes necessary.

The side-line CW laser and off-line CW laser are brought into an optical switch that can be electronically addressed to select the laser. The selected wavelength is then sent to injection seed the pulsed laser alternately in on/off wavelength, so that the frequency of the pulse laser follows exactly of the well controlled frequency characteristics of the CW lasers.

The engineering design of the wavelength control unit is shown in Figure 2. The cell is an adjustable absorption length cell with maximum length of 8 meters. Three CW lasers, an EO modulator, two detector units, an optical switch, fiber couplers and connectors are all packaged in the custom designed 19 inch rack mountable box.

2.2 Laser Transmitter

The right side block in the Figure 1 of the lidar instrument contains laser transmitter, telescope, detector unit and data acquisition and process unit.

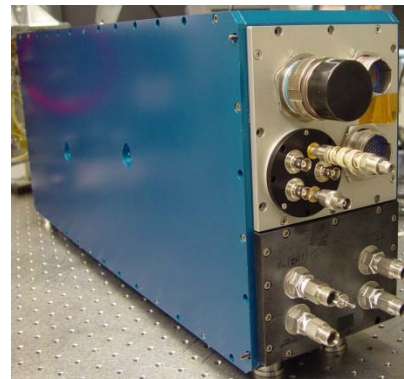

Figure 3 Engineering packaged laser transmitter

The compact, rugged, highly reliable laser transmitter is based on Ho:Tm:YLF high-energy 2-micron pulsed laser technology [10]. This laser transmitter is side pumped by AlGaAs diode arrays at 792nm. The laser transmitter is designed to be operated in unique double pulse format to mitigate the effect of the surface reflection difference between the on-and-off line pulses on the precision of the IPDA measurement. When the Ho upper laser level population reaches its maximum value at the end of the pump cycle, a first Q-switched pulse is generated which extracts the energy stored in the Ho⁵I₇ upper laser level, resulting in a sharp decrease in the upper laser level population. Then, a new equilibrium between the Tm³F₄ and Ho⁵I₇ manifolds is established by energy transfer from the excited Tm ions towards Ho ions even though the pump no longer exists. The Ho upper laser level ⁵I₇ comes to its second maximum about 150 μs after the first pulse. The second

Q-switch pulse is triggered at this moment resulting in the desired double pulse operation. A unique feature of this laser operation is that it provides two Q-switched pulses with a single pump pulse. Since the time difference between the pulses is only about 150 μ s, the overlap between the two pulse foot prints on the ground is greater than 95% for a airborne flight platform.

The exact wavelengths of the pulsed laser transmitter are controlled by the wavelength control unit output. The first pulse and the second pulse was injection seeded alternately by the side-line frequency and the off-line frequency. All the optical mounts are custom designed and have space heritage. They are designed to be adjustable and lockable and hardened to withstand vibrations that can occur in airborne operation. Figure 3 is a picture of the engineering packaged laser transmitter. The laser transmitter is 11.5 x 26.5 x 6.4 inch (29 x 67.3 x 16.5 cm) in size, and weighted less than 70lbs.

2.3 Telescope

The telescope is a custom designed Newtonian type with 40cm diameter primary mirror size. This primary mirror is made of aluminum with diamond turning machining technique. The shape of the primary mirror is hyperbolic to minimize the aberration, so that the returning signal can be focused to less than 300 micron diameter spot size to fit in the detector selected. The telescope is designed to maintain the focus point position in the temperature range between 5 and 35 °C.

2.4 Detector

A high sensitivity with low noise equivalent power (NEP) detector in the 2-micron wavelength region suitable for detecting atmospheric returning signal from airborne or space borne lidar instrument is yet been developed. However, the detector suitable for detecting the lidar returning signal from hard targets, such as ground surface, is commercially available. The Hamamatsu InGaAs PIN photodiodes, model G5852, is selected and characterized for the airborne IPDA lidar application. To obtain fast response and low noise required for the lidar signal detection, the diameter of the detector active area is limited to 300 micron. Thus, the NEP value is measured at 6.8×10^{-14} W/Hz^{0.5} at 30°C, which is well suited for the IPDA lidar.

2.5 Data Acquisition and process unit

The lidar signal will be digitized by a data acquisition unit. The data acquisition unit is built on two Agilent 10-bit DC252 digitizers housed in a 5 slot Compact PCI 6U crate also manufactured by Agilent. Each digitizer can sample up to 8 GHz with 1 G point acquisition memory. Due to the large acquisition memory size, a long history of data can be monitored before the data

extraction process. The two digitizers can be synchronized to the same external trigger signal so that both the trigger and the analog lidar return signals can be digitized simultaneously. The data acquisition software is written in Visual C++ to control the digitization specification such as the sampling frequency, the length of data to be acquired, the trigger signal configuration, the look direction of the telescope, and the specification of data archive. The system runs Microsoft XP with a 64-bit/66 MHz PCI bus, which is capable of transferring data at sustained rates up to 400 MB/sec to host PC. The system is able to digitize a large amount of lidar return signal at a fast trigger rate with the given specifications.

3. INSTRUMENT INTEGRATION

The lidar system will be baseline designed for integration to a small research aircraft B-200. By considering fitting the CO₂ IPDA instrument into a B-200 aircraft platform, the completed lidar system shall be easily adapted to any other bigger aircraft compared to B-200 such as DC-8 aircraft. The mechanical design of the CO₂ IPDA lidar system will be compact and light to meet all the payload requirements for the aircraft; and also has sufficient payload capacity to fly validation instruments simultaneously.

The lidar integration includes mechanical system design, fabrication, integration, testing and verification of system performance with respect to aircraft's flight loading profile. A mechanical supporting structure is been designed to integrate the transmitter, the telescope and receiver onto an adjustable, yet rigid platform. The primary objective of this structure is to maintain alignment integrity throughout the operating flight envelope of the aircraft; and at the same time minimize aircraft vibration from adversely affect the lidar measurement. The mechanical structure will be optimized to satisfy the stiffness, mass and volume constraints of the aircraft. Figure 4 shows a preliminary design concept of the Transmitter-Telescope-Receiver Integrating Structure of the CO₂ IPDA Lidar system as installed in a B-200 aircraft. The optical portal has already modified and installed to readily accept the lidar system as shown.

One 19" x 20U tall rack will be used to support diode laser driver, control electronics, wavelength control unit and data acquisition system. Another 19" x 12U rack will be used to mount solid state chillers and a thermal control unit.

The integrated lidar instrument will be tested in ground with horizontal target setup before the lidar instrument is integrated into the aircraft. The number density of CO₂ along with pressure, temperature, and relative humidity information obtained from ancillary

measurement from in situ sensors is calculated to derive dry CO₂ mixing ratio. The data obtained during instrument testing will be evaluated, including comparisons to in situ instruments and evaluation of the data with respect to the weather and geographical environment. The goal will be evaluation of the performance of the lidar relative to the scientific measurement goals.

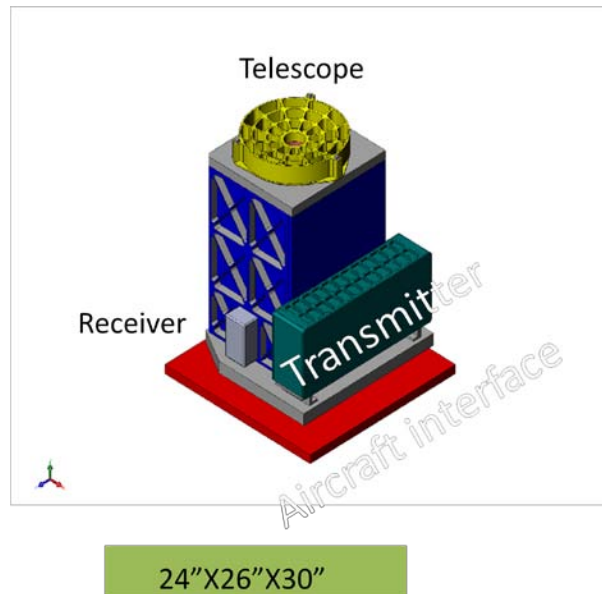

Figure 4. Integrated Transmitter-Telescope-Receiver structure of the IPDA lidar instrument that will fit in a small aircraft such as B-200

4. SUMMARY

NASA Langley is developing a pulsed, high energy 2-micron IPDA lidar instrument for CO₂ concentration measurement by direct detection technique. The lidar transmitter is a unique double pulsed Ho laser capable of producing ~100mJ energy per pulse; and it is compactly and ruggedly packaged. High accuracy, stable and repeatable wavelength control and switching unit has been demonstrated. This unit is upgraded and engineering packaged to become a flyable unit. Sixteen inches telescope is designed and in the progress of manufacture. Detector has been purchased and characterized for the IPDA application. Data acquisition unit, electrical control unit and thermal control unit are been developed and tested. The integrated IPDA lidar structure is being designed to fit in B-200 research aircraft. It is expected to provide a unique instrument tool for measuring atmospheric CO₂ concentration.

REFERENCES

- [1] National Research Council (NRC), "Earth Science and Applications from Space: National Imperatives for the Next Decade and Beyond," p. 4-9, The National Academies Press, Washington DC, "Decadal Survey (DS)"
- [2] James Abshire et al, Pulsed airborne lidar measurements of atmospheric CO₂ column absorption, *Tellus* 1 -14, (2010).
- [3] Michael Dobbs, Jeremy Dobler, Michael Bruan, Doug McGregor, Jay Overbeck, Berrien Moore III, Edward Browell, T. S. Zaccheo, "A modulated CW fiber laser-lidar suite for ASCENDS mission", 24th International laser radar conference, June. 2008
- [4] Menzies R. T. and D. M. Tratt, 2003: "Differential laser absorption spectrometry for global profiling of tropospheric carbon dioxide: selection of optimum sounding frequencies for high-precision measurements", *Appl. Opt.*, **42**, pp. 6569-6577, 2003
- [5] Ambrico, P. E., A. A. Amodeo, P. D. Gilaramo, and N. Spinelli, "Sensitivity analysis of differential absorption lidar measurements in the mid-infrared region", *Appl. Opt.*, **39**, 6847-6865, 2000
- [6] Regalia-Jarlot, L., V. Zeninari, B. Parvitte, A. Grosseil, X. Thomas, P. von der Heyden, and G. Durry A complete study of the line intensities of four bands of CO₂ around 1.6 and 2.0 μm : A comparison between Fourier transform and diode laser measurements, *J. Quant. Spectr. and Rad. Trans.* **101**, 325-335, 2006
- [7] Joly L., Marnas F., Gibert F., Bruneau D., Grouiez B., Flamant P., Durry G., Dumelie N., Parvitte B., and Zeninari V, "Laser diode absorption spectroscopy for accurate CO₂ line parameters at 2 μm : consequences for space-based DIAL measurements and potential biases", *Appl. Opt.*, **48**, 5475-5483, 2009
- [8] Ehret G., C. Kiemle, 2005 Requirement definition for future DIAL instruments, final report to ESA contract, p64
- [9] Koch, G. J., J. Y. Beyon, F. Gibert, B. W. Barnes, S. Ismail, M. Petros, P. J. Petzar, J. Yu, E. A. Modlin, K. J. Davis, and U. N. Singh, 2008: "Side-line tunable laser transmitter for Differential Absorption Lidar measurement of CO₂: Design and application to atmospheric measurement", *Appl. Opt.* **47**, 944-956
- [10] Yu J., U. N. Singh, N. P. Barnes, and M. Petros, 1998: "125-mJ diode-pumped injection-seeded Ho:Tm:YLF laser", *Optics Letters* **23**, 780-782