



Aeroservoelastic Sensor-based Control

**(certifiable-by-design with
performance and stability guarantees)**

Marty Brenner, NASA Dryden FRC

FAP Technical Conference, March 13 - 15, 2012

Distributed Physics-Based Aerodynamic Sensing



STATUS QUO



Lightweight configurations => inherently flexible

Current limitations:

- Complex aerostructural control
- Limited aerodynamic observables
- Measurement/inertial uncertainty/lags
- Cost-ineffectiveness / hi-maintenance

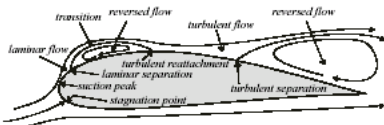

NEW INSIGHTS

Flow bifurcation point (FBP) model captures stagnation point, stall, separation, SBL flow dynamics

Aerobservable-based analytic codes

Distributed sensing/control apps with spatio-temporal feedback

V&V of CFD/CSD for unsteady ASE

Aero coefficient estimation

Force-feedback framework

GLA/LCO control; flutter prevention



PROBLEM / NEED BEING ADDRESSED

MAIN ACHIEVEMENT:

Relevant Sensor Information-based Distributed Aeroservoelastic Control for Reliability, Effective Performance and Robustness

Challenges:

Physics-based Fly-by-Feel (FBF) architecture

Distributed control with alternative sensors

Information-based sensing for efficient mission adaptivity with aerostructural control

Development of physics-based analytical aerostructural feedback mechanism

HOW IT WORKS:

Real-time aerodynamic force measurement improves aerostructural performance and efficiency across all flight regimes (sub/trans/sup/hyper)

Redundancy with analytical sensing critical to reduce aerostructural uncertainty

Decouples the aerodynamics (forces) from the structural dynamics (responses)

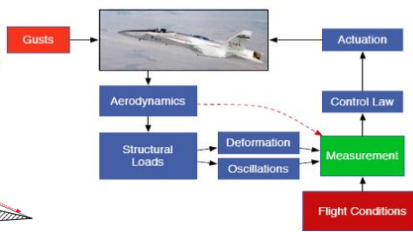
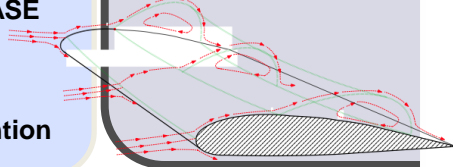
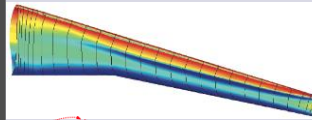

QUANTITATIVE IMPACT

[FAP] Reduce drag & weight; Increase performance & energy efficiency; Improve CFD-CSD and experimental tools & processes with reduced uncertainty; Develop/test/analyze advanced multi-disciplinary concepts & technologies;

[AvSP] LOC prevention, mitigation, and recovery in hazardous flight conditions
AFRL/LMCO (MUTT), NASA-OCT

Partners: UMN, TAMU, Caltech, SBC (sensing)



PROGRAM GOALS

- Design and simulate robust control laws (UMN, SBC, DFRC) augmented with the aerodynamic observables
- Conduct wind tunnel tests (TAMU) and flight test (DFRC) to validate the controls
- **Ultimate objective is to determine the extent of performance improvement in comparison to conventional systems with multi-functional spatially distributed sensor-based flight control**

Flight systems operating near performance and stability limits require continuous, robust autonomy through real-time performance-based measurements

Approach to Enabling Fly-by-Feel Control

STATUS QUO

- Lightweight structures => inherently flexible
- Current limitations:
 - Aerostructural model uncertainty
 - Limited aerodynamic observables
 - No flow separation or shock info
 - Measurement/inertial uncertainty/lags
 - Actuator uncertainty/lags



NEW INSIGHTS

- Flow bifurcation point (FBP) model maps surface flow topology to aerodynamic coefficients (CL, CM, CD)
- Distributed sensing/control enabled with spatiotemporal aerodynamic feedback
- Force feedback enabled by sensing FBPs, *aerobservables*
- Robust control enables stability under sensor, actuator & model uncertainty

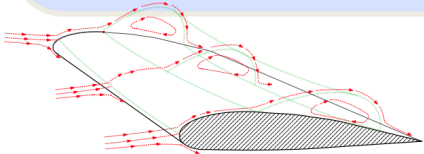

PROBLEM / NEED BEING ADDRESSED

Theoretical/experimental tools to validate stability and performance of robust control with Fly-by-Feel sensing

PROGRAM DESCRIPTION:

Validate robust control laws augmented with aerodynamic observables in aerostructural wind tunnel (WT) / flight test (FT) [currently TRL 2-3]

Challenges:

- Development of analytical codes for nonlinear aerodynamics with compressibility effects
- Developing aeroservoelastic (ASE) sim with unsteady aerodynamics for developing robust control laws
- Developing low-power sensor technology robust in operational environments

Critical Technologies:

- FBP model for CL/CD/CM for subsonic/transonic flows
- Low power/noise instrumentation and DSP techniques
- Sensor, actuator & ASE model including uncertainties
- Robust control for sensor/actuator/model uncertainties

Approach:

- Design/validate robust control laws for ASE WT/FT
- Develop FBP-based model including compressibility
- Develop low-power FBP sensor array

QUANTITATIVE IMPACT



- Improved worst-case performance under uncertainty
 - Gust load alleviation
 - Flutter prevention envelope
 - Suppression of limit cycle
- Feedback control performance is limited by time-delay



PROGRAM GOAL

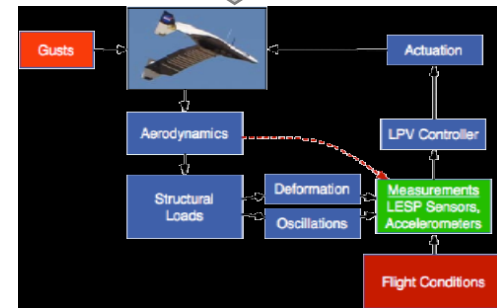

- Provide technology foundation for an autonomous Fly-by-Feel platform demonstrating:
 - Aerodynamic / structural efficiency for range / endurance
 - Mission-adaptive capability
 - Maneuverability

Operating near performance and stability limits requires real-time force feedback

Previous Analytical Approaches

- LE stagnation point (LESP, x_l)
Flow separation point (FSP, x_s)
- L.C. Woods: any two of the three (AoA, FSP, LESP) fully determines the system

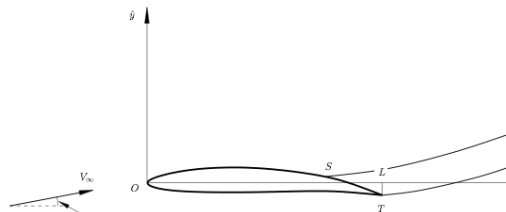

$$C_L(\alpha, x) = \frac{\pi}{2} \sin(\alpha) (1 + \sqrt{x})^2$$

$$\tau_1 \frac{dx}{dt} + x = x_0(\alpha - \tau_2 \dot{\alpha})$$

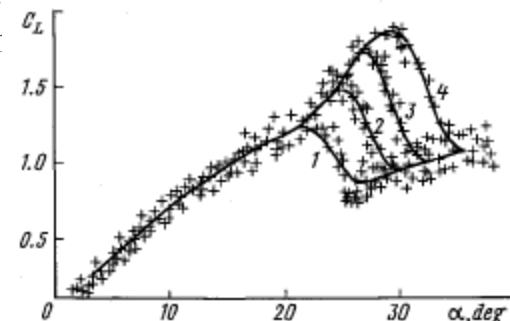

- Goman & Khrabrov
 - AoA & FSP => aero coeffs
 - Unsteady experiments for τ_1, τ_2 time constants
 - Based on thin airfoil theory
- What is AoA in unsteady flows?

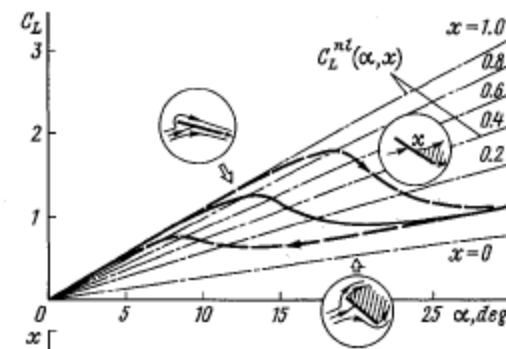
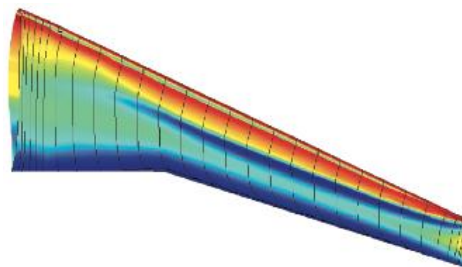

$$x_l = \sqrt{2} x_s^{1/4} \left\{ \alpha_* - \frac{1}{\pi} \int_{-1}^{\sqrt{x_s}} \frac{G(\zeta')}{\zeta'} d\zeta' \right\}$$

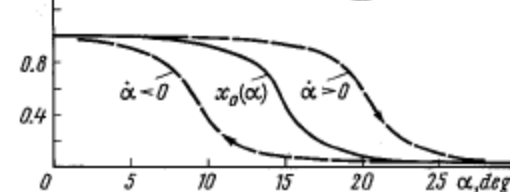

- AFRL/NASA TDT [aeroservoelastic control]
- NASA ATW [flutter]
- Sandia National Lab [smart blade]
- AFRL SARL [flow control]
- AFRL/NASA OSU [transonic shock]
- AFRL/NASA/LM BFF [flutter suppression]
- AFRL X-HALE [aeroservoelastic modeling/ground test/flight test]
- Relevant Past Experiments
 - NASA F-15B tail
 - NASA F-15B: shock location

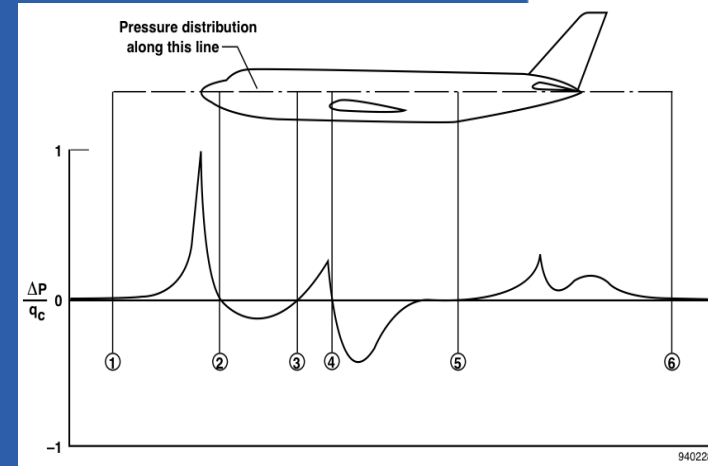

Subsonic Aeronautics Research Laboratory (SARL) @ Wright-Pat AFB

- Cambered airfoil w/ Flexsys conformal flap
- Low aspect ratio => significant 3D flow
- Pressure taps to obtain pressure distribution & lift / moments
- Hot-film sensors
 - Leading-edge => stagnation point
 - Upper surface => flow separation
 - Phase reversal signature

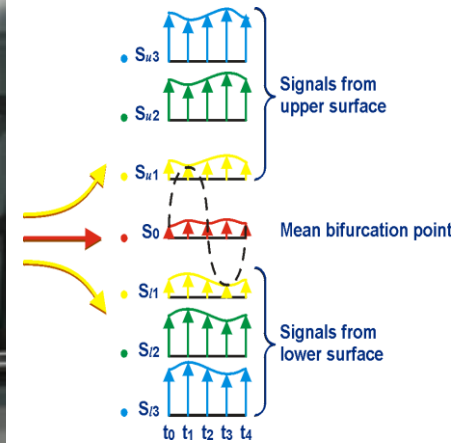
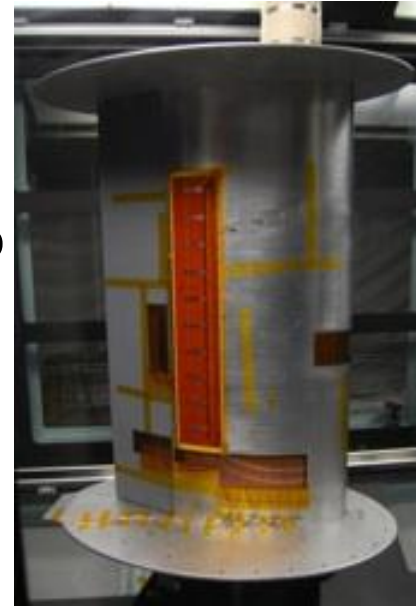

Effect of plasma on circulation/flow separation

- Trigger control on FBP characteristics

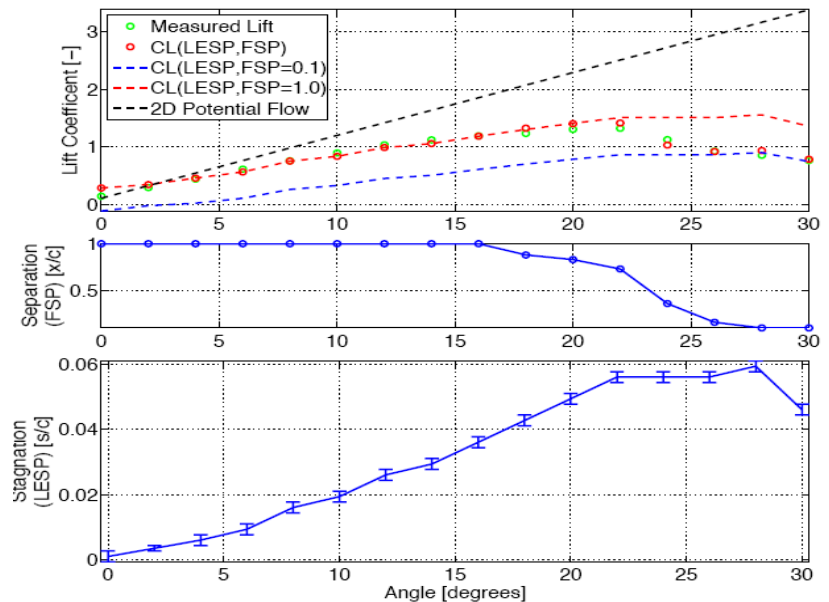

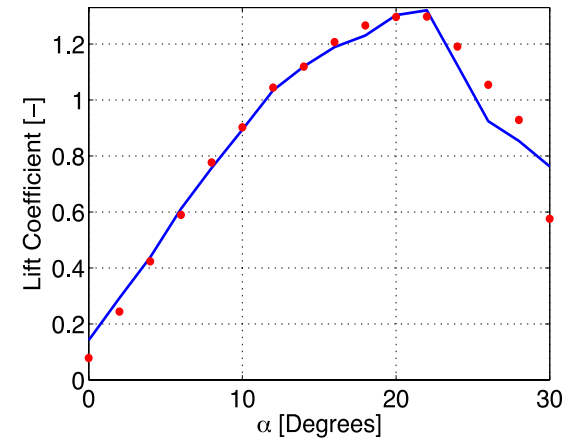
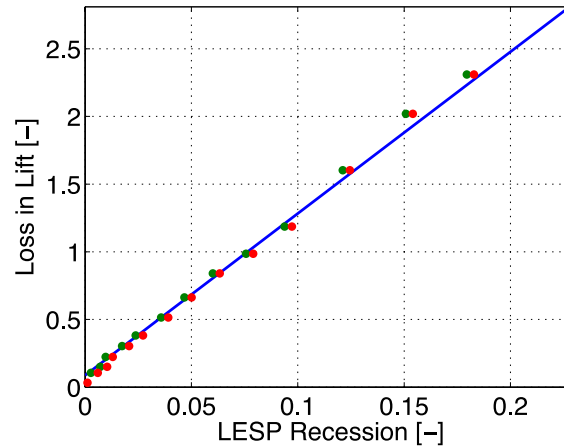
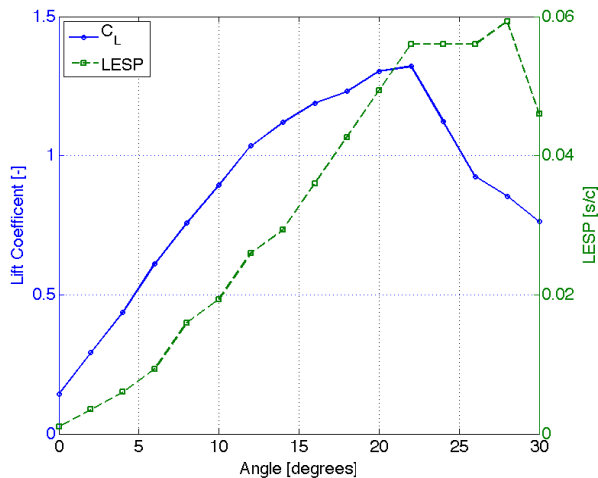

- Low aspect ratio wing stalls ~ 22 degrees
- LESP location does not decrease until 28 degrees
- Loss in lift obtained from Kutta condition **minus** the actual measured lift
- LESP recession
 - LESP location associated w/ Kutta condition lift **minus** actual LESP
 - Monotonic (one-to-one mapping) & mostly linear with loss in lift
 - LESP & AoA used to obtain lift coefficient through stall
- Reason: LESP location is monotonically related to AoA and circulation/lift

NASA LaRC TDT Test : NGC / LMCO

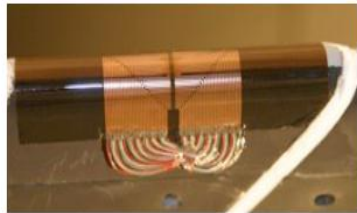
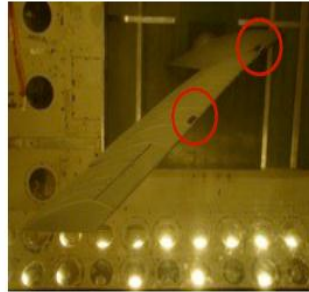
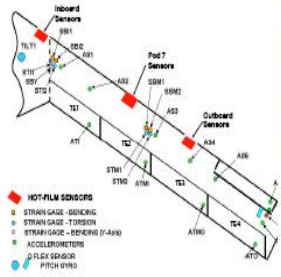

ASE control techniques

- Effect of delay in ASE control
- Adaptive control: requires bounded uncertainty in physics
- Bounds particularly important for aeroelastic applications (3D)

FBP-based control

- Exploit passivity of aeroelastic system by shaping lift/moment
- Reduce uncertainty of flow physics through direct estimation of parameter intrinsically related to lift

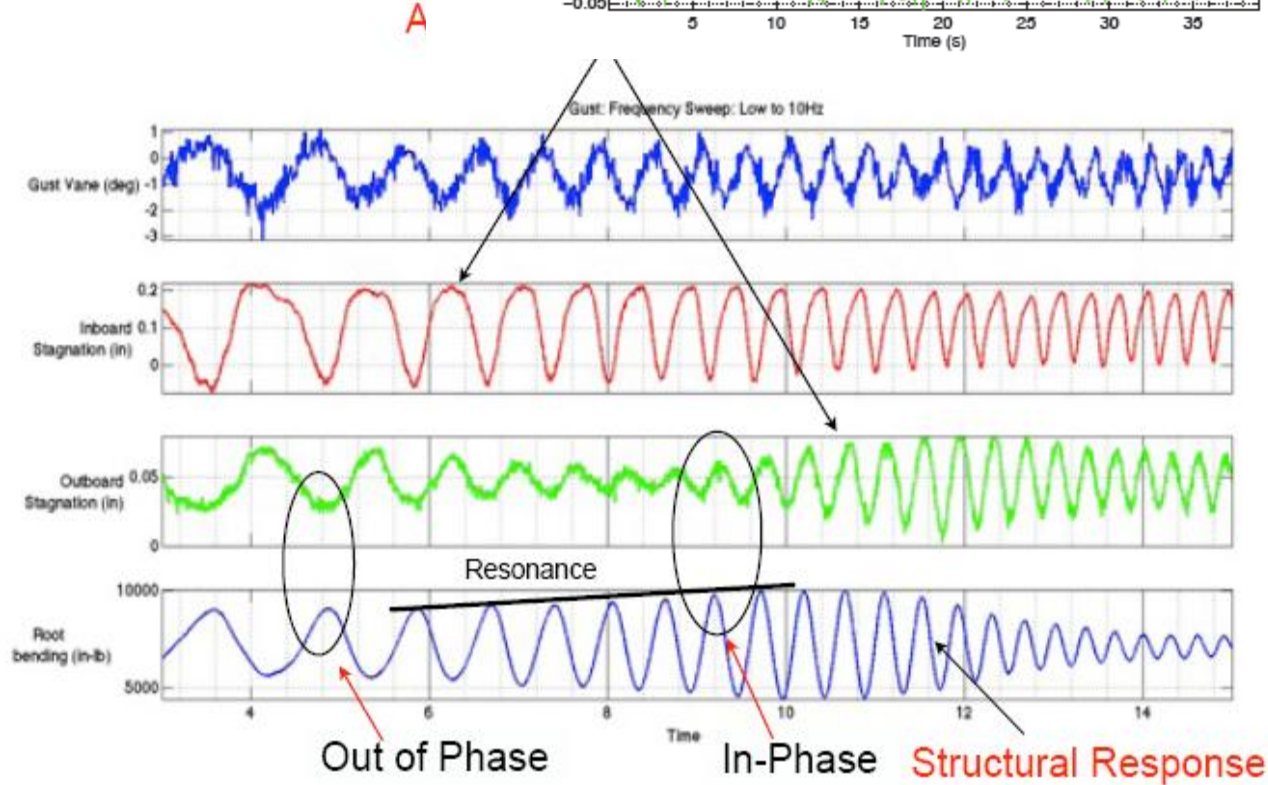
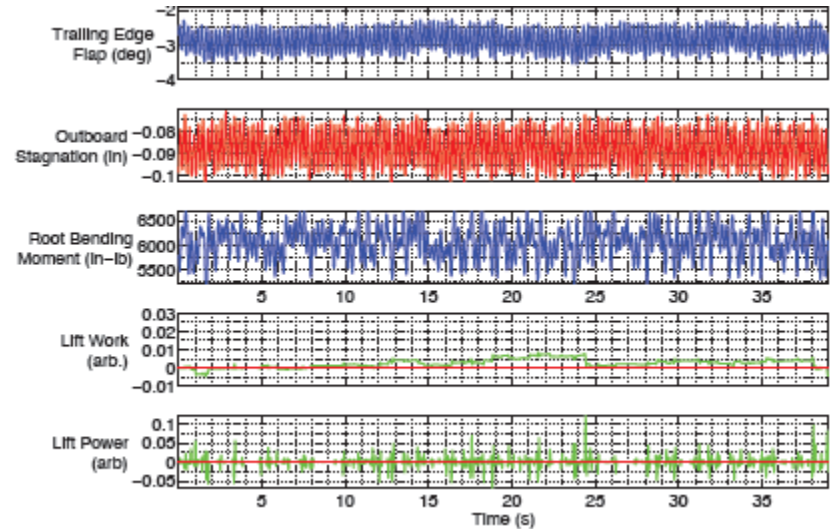

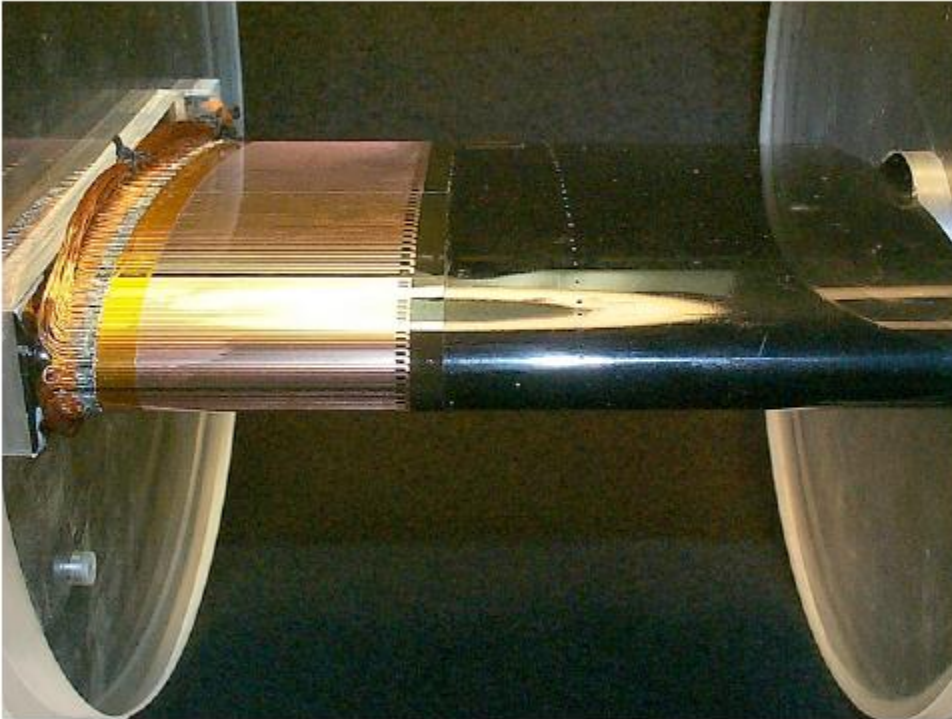

- OSU Tunnel
 - 6" x 22" blow down facility
 - Mach: 0.2 – 0.77
 - Re: 5 – 25 M
- Airfoils
 - NACA 0021
 - NACA 4415
- Instrumentation
 - Hot-film sensors
 - Pressure sensors

NASA ATW Flight Test



- Aerostructures Test Wing
- On F-15 test fixture
- Onset of flutter
- Instrumentation
- Hot-film sensors
 - Leading-edge
 - Angularity probe
- Accelerometers
- Strain gages
- Air data

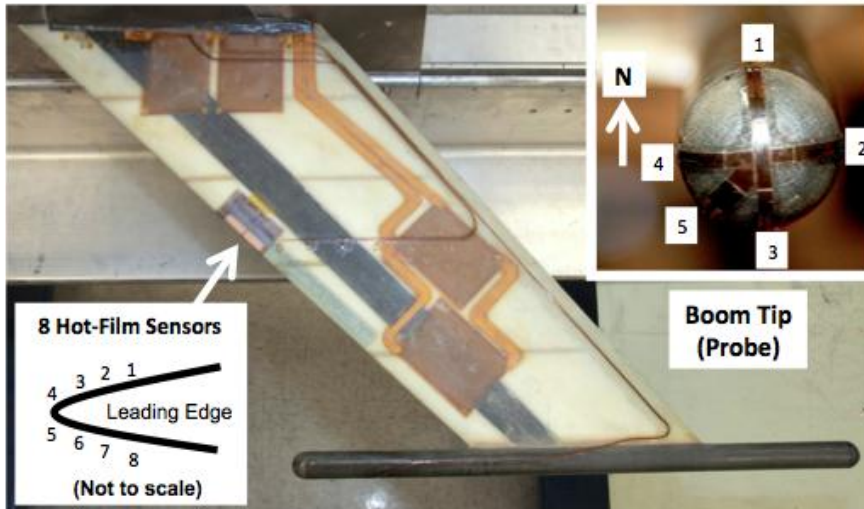



ATW Test Data

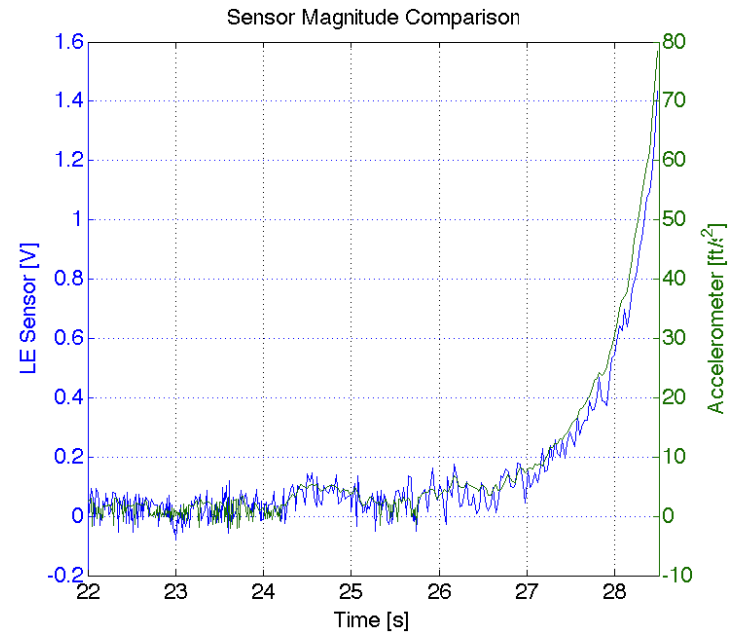
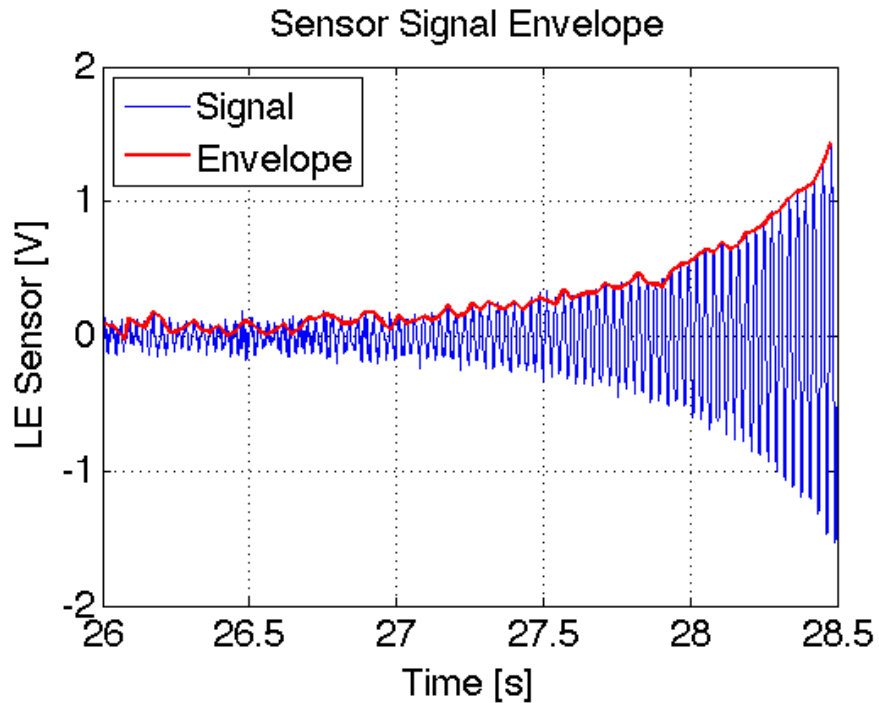

LESP amplitude increases like that of a force measurement



ATW Test Data

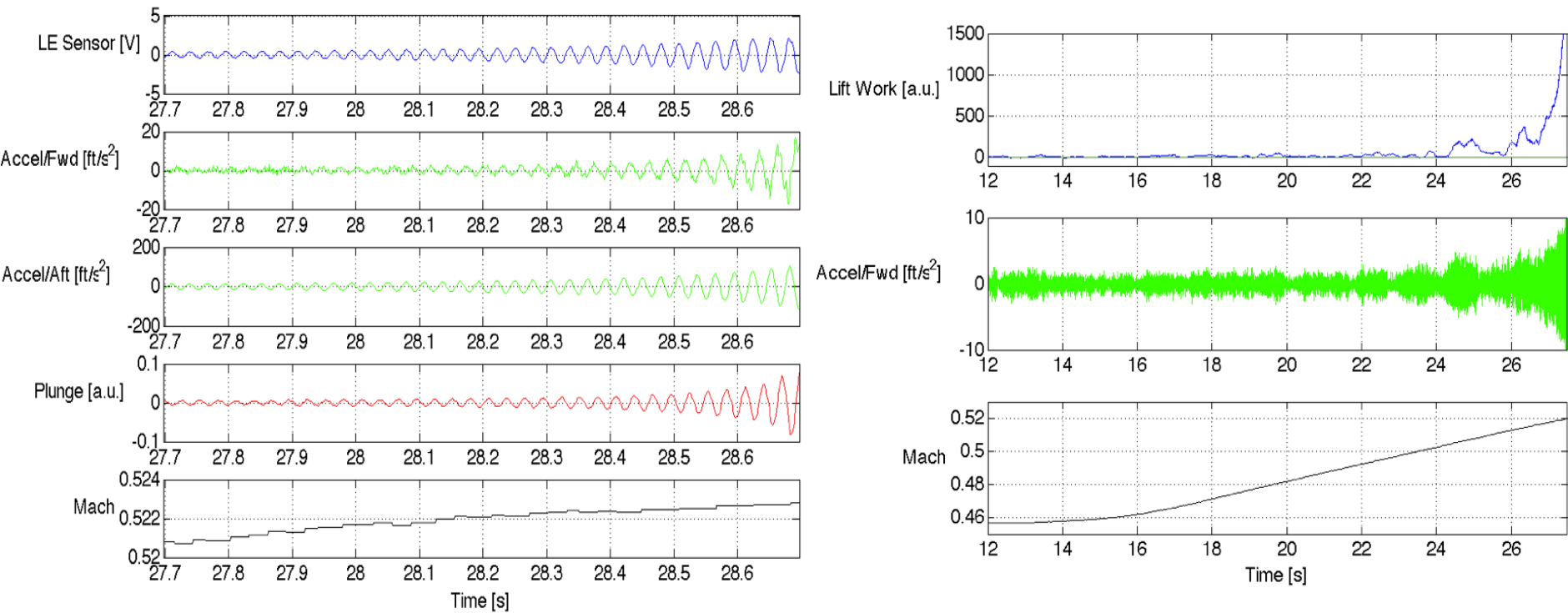

Estimate plunge from co-located fore/aft accels
Work done by fluid on the structure w/Mach

$$W_L = \int (L - \bar{L}) \dot{h} dt$$

ATW Summary

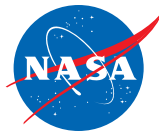

- Developed flow bifurcation point (FBP)-based aerodynamic model
 - Validated model for subsonic flows (SARL)
 - Demonstrated LESP & FSP => CL
 - Consequence: no air data parameters required for aerodynamic coefficients
 - Curve-fitting may not be required
- Flutter test: ATW2 (NASA Dryden)
 - Significant flow separation at low angles of attack during onset of flutter
 - LESP magnitude similar to a force-type measurement
 - Use of accelerometers + LESP to estimate aerodynamic work
 - Potential for passivity-based control

BFF GLA/Flutter Control Demo: LMCO / AFRL

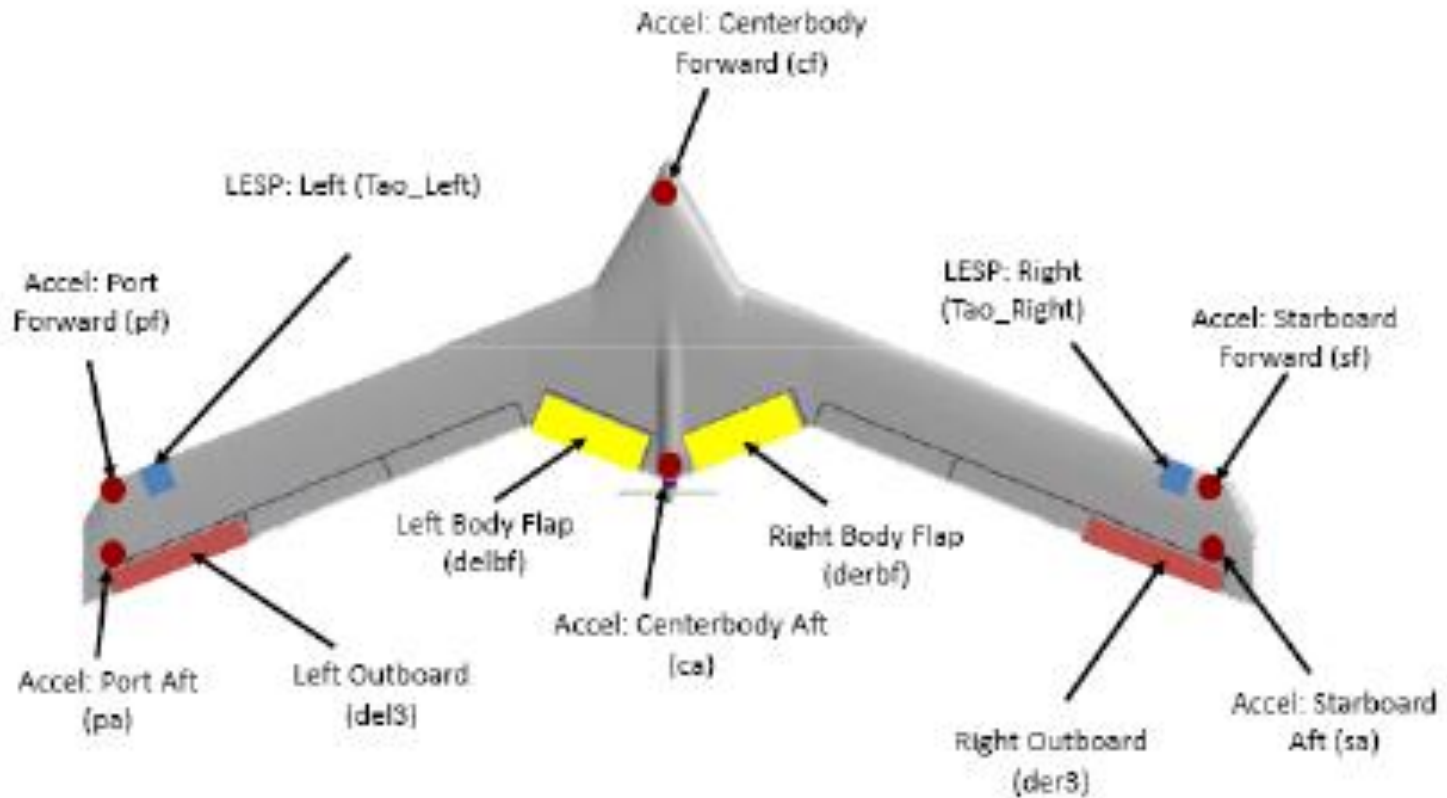

FBP-LESP Ground and Flight Testing To-Date



- Developed flow bifurcation point (FBP)-based aerodynamic model
 - Validated model for subsonic flows (SARL)
 - Demonstrated LESP & FSP => CL
 - Consequence: no air data parameters required for aero. coeffs.
- Optimized sensor & instrumentation for FBP detection
 - Sub-millisecond response
 - Minimal sensor calibration (automated)
 - Identification of LESP with minimal # of sensors
 - Instrumentation: practical immunity to EMI/RFI
 - Flight-hardened multi-channel system
- Demonstrated gust load alleviation (GLA) using FBP feedback
 - Improved GLA w/ less control effort than structural feedback alone
- Test Applications
 - Low-speed (SARL) [flow control] and high-speed (OSU) [transonic]
 - Flight tests: ATW2 (DFRC) [flutter] and BFF (LMCO) [flutter]
 - Other: Sandia [wind energy]

FBP Model Validation: TAMU

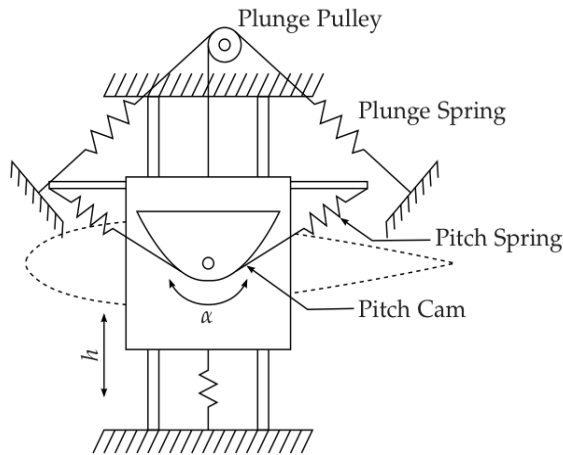
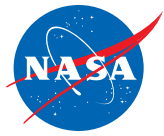

- Does the FBP relationship with aero coeffs. hold for unsteady cases?
- Texas A&M Pitch-and-Plunge Apparatus (PAPA)
 - Free PAPA: LCOs / flutter and robust control law development
 - Forced PAPA: pitch/plunge dwell/sweep with pitch/plunge dwell
 - Wings with control surfaces and instrumented w/ load balance, accels, optical encoders, etc. for developing relationship between FBPs, pitch/plunge rates, control surface deflection and aero coeffs

Fly-by-Feel Testing:

FBP Model for Steady Lift Estimation

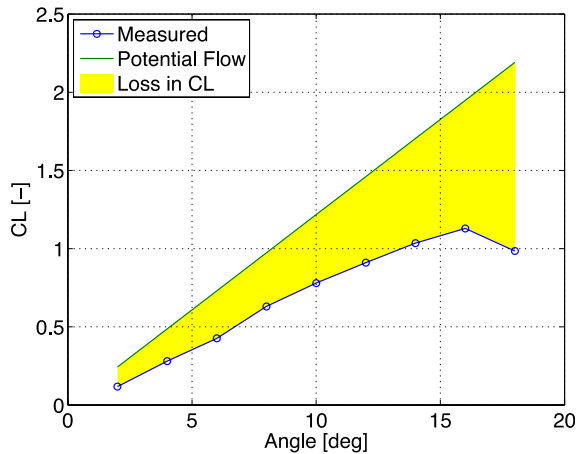

Notes - open-loop test in a free PAPA

- CL is non-monotonic, non-unique function of AoA through stall (conventional)
- Loss in CL is monotonic function of LESP recession through stall (new)

Calibration:
CL(LESP, AoA)

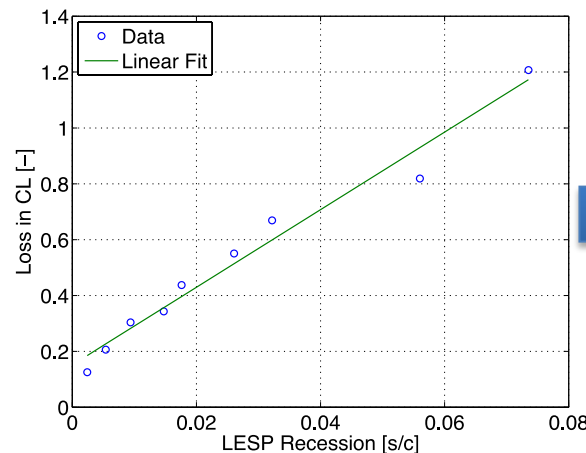

Lift Estimation
Through Stall

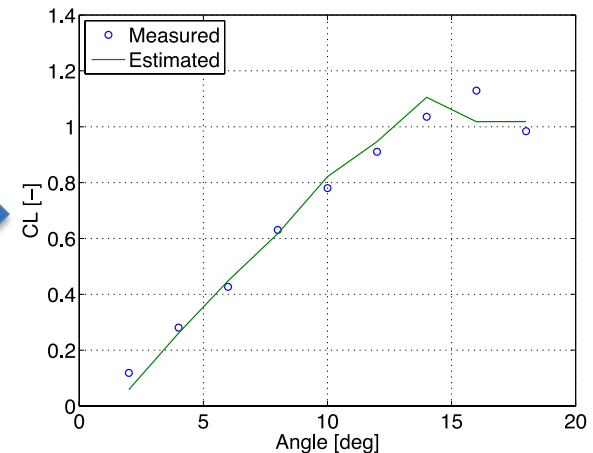

↕ (CL, AoA) & (LESP, AoA)

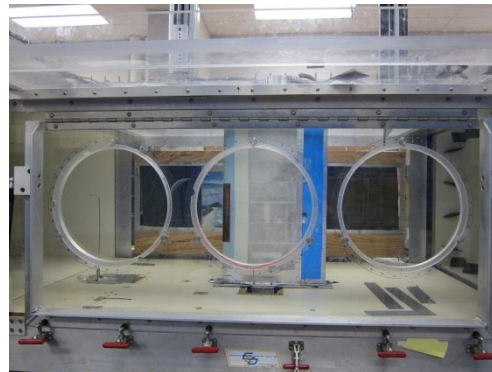
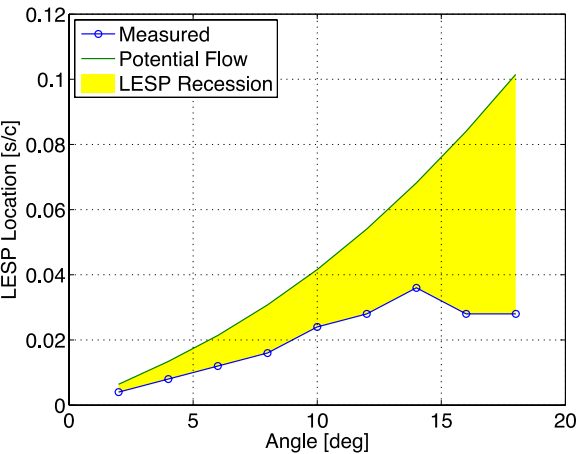
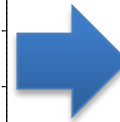

Next Steps

- Development and validation of closed-loop ASE controller for suppressing limit cycle oscillation in TAMU wind tunnel
- Extension of FBP model to transonic/supersonic flows including effect of shock wave boundary layer interaction

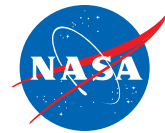

Fly-by-Feel Testing:

FBP Model for Unsteady Lift Estimation

Next tests - forced PAPA

Objective of this test is to relate the movement of flow bifurcation points, e.g. LESP, and flow separation point to the aerodynamic forces under increasing pitch rates

Will enable calibration of the wing for unsteady response and closed-loop free PAPA tests



MUTT-like wing instrumented at three span stations

Follow-on Work

Develop open-loop / closed-loop test procedures for upcoming tests on the F-18 with AFRL under the RASSCAL program,

Follow-on NASA work in distributed aeroservoelastic control on the X-56A vehicle – low power, small volume, robust sensing

Fly-by-Feel Aerodynamic Sensing

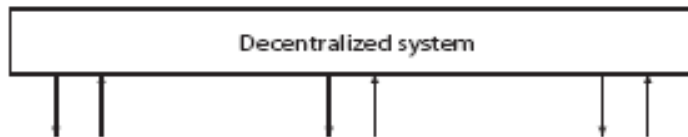
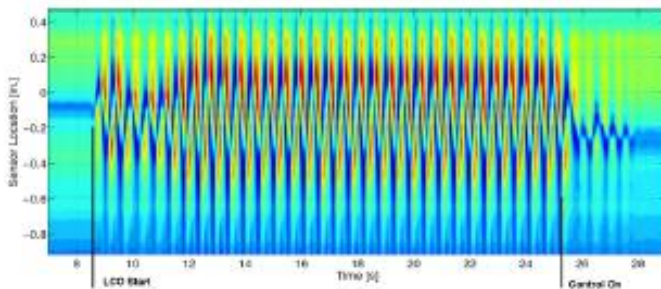
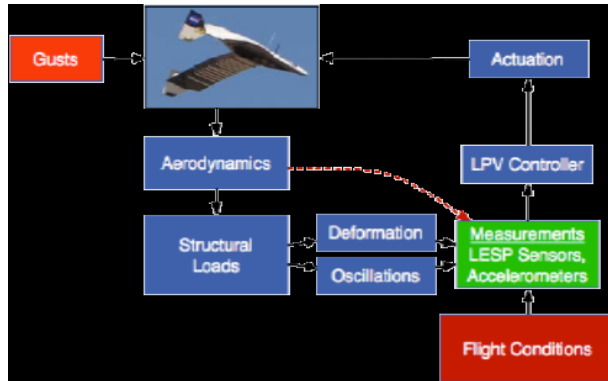

Fig. 1. Diagram of a decentralized system.

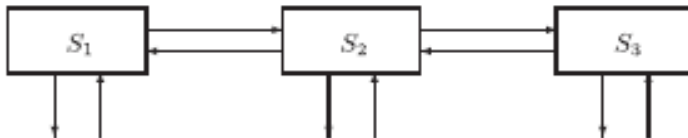

Fig. 2. Diagram of a distributed system.

Potential Near-Term Opportunities

- Extension of physics-based FBP analytical model to generalized vortex state (low-order fluids model)
 - Applicable to unsteady flows (high reduced frequencies & near-/post-stall pitch angles)
 - Capture vortex dynamics for flow control
 - Consistent with higher-order CFD models
 - Enables near-term flight test flow control demos
- Extension of physics-based FBP analytical model to compressible flows
 - Applicable to characterizing shock wave turbulent boundary layer interactions (SBLI) as it relates to performance and aeroelastic stability
 - Reduction of noise & emissions
 - Flight test opportunities at relevant conditions
- Development of distributed ASE control architecture enabled with “calibration-less” or self-calibrating sensors
 - New formulation of ASE eqns may reduce the requirement for calibration provided that flow and structural sensors are both available
 - Distributed control architecture may reduce requirements for structural & aerodynamic model accuracy by proving that local control approaches stable, globally optimal control
 - Provably robust adaptive control
- Partners: UMN, CalTech, SBCs, LMCO, AFRL, etc.



Robust-Network Sensor-based Distributed Control

Spatially distributed physical components with sensors/actuators/processors interconnected in arbitrary ways: **problem-dependent traffic interaction**

Processing units interconnected by dynamic communication networks requiring closed-loop ID with distributed estimation/optimization/control

Multi-scale-level information sharing with layering architecture

Model structure exploited for optimal performance design

“Layering as Optimization Decomposition”

Optimal solution in modularized and distributed manner

Top-down design layered stacks -> conceptual simplicity

Functionality allocation motivated by “architecture first”

Enables scalable and evolvable network designs

Decompositions have different characteristics

in efficiency, robustness, asymmetry of information and

control, and tradeoff between computation and communication.

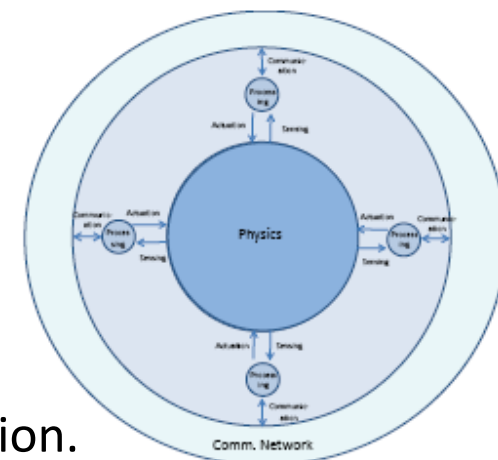
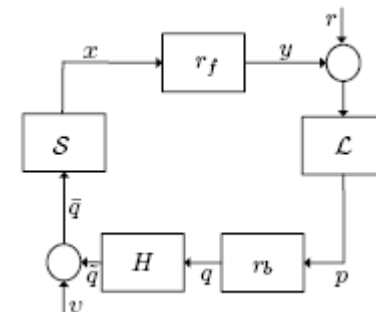

Essentials of Sensor-based Distributed Control

Physics-based sensory perception and reaction

- relevant data-driven autonomy (biomimetic)
- spatio-temporal, multi-scale, viscosity, SBLI
- advanced real-time aerostructural measurements

Distributed multi-objective energy-based control

- efficient mission adaptivity with reliability and safety
- inherent passivity/dissipativity with optimal energy-force distribution
- spatial uncertainty minimization with local control and robust global feasibility
centralized (fusion-centric) vs decentralized / coordinated degree of hierarchy
- coordinated subsystem-independent control (min state variance and input)

Network sensor/comm modeling (adaptive layered topology, who-what-when?)

- Sensornets: complex interactions \leftrightarrow protocol layering = optimal decomposition
- Multi-level network control/estimation and information architectures

Decentralization with compressive information-based sensing/identification

Consensus-coordinated network control with coupling/compatibility constraints

Multi-MIMO stability / robustness analysis in sensing/communication/control

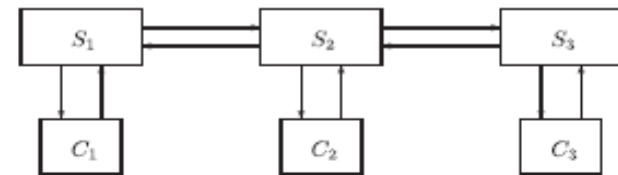
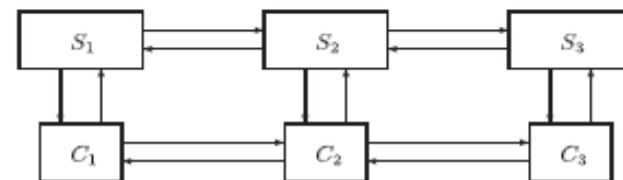

Fig. 3. Diagram of the control architecture of distributed control.



Robust Networks for Sensor-based Distributed Control

Advanced technology's near-biological complexity

- level of organization, architecture, and the role of layering, protocols, and feedback control in structuring complex multi-scale modularity
- protocol layers hide complexity of layer below and provide service to layers above
- follows necessarily from their universal system requirements to be fast, efficient, adaptive, evolvable, and robust to perturbations in their environment and component parts
- local algorithms attempt to achieve a global objective (consensus-based)
- make transparent the interactions among different components and their global behavior

Lack of stability robustness plays fundamental role in wall turbulence (Caltech, etc)

- Energy amplification (high gain feedback) and increased velocity gradient at the wall associated with the turbulent profile **appears to have important implications for flow control techniques that target skin friction or the mean profile (2D/3C model)**
- As Re increases, robustness (laminar-to-turbulent) decreases
- Tradeoff between linear amplification and non-linear blunting

Turbulence in robust control framework

- Reveals important tradeoff between linear / non-linear phenomena
- Provides insight into mechanisms associated with both transition and fully turbulent flow

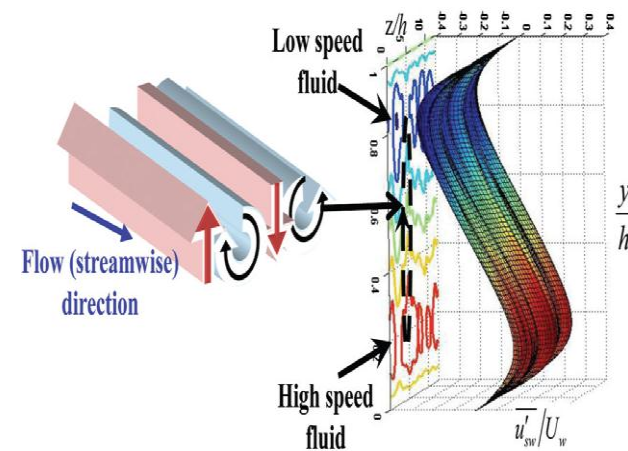
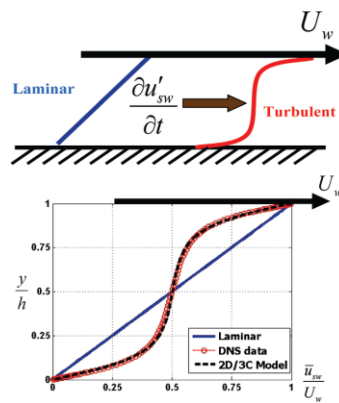



Real-time Aerodynamic and Structural Sensing for Controlling Aeroelastic Loads (RASSCAL)

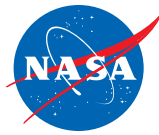

Objectives

- Measure aerodynamic and structural loads with structurally embeddable sensors through the complete fighter flight regime.
- Apply structurally integrated electronics concepts
- Correlate with computational and empirical models for fly-by-feel demonstrations.

Technical challenges

- Transition laboratory sensors to flight environment
- Ingress/Egress of electronics in structure
- Model validation with flight data

Background

- Leverages recent SBIR techs and 853 Stick-to-Stress sim
- Leverages \$14M (+\$15M labor) NASA upgrade to test bed plus future commitment to this flight research
- Leverages ISHM and contributes to “fly-by-feel” vision
- Testbed capable of sub-, trans-, and super-sonic flight
- LRS, 6th Gen Fighter transition opportunities

Potential Fly-by-Feel Applications

- exploitation of stall to reduce landing distance
- control of unsteady loads for maneuver, LCO, or gust
- active feedback of critical structural load such as wing root bending moment
- diagnostic capability for “high cost events”

Tasks/Schedule

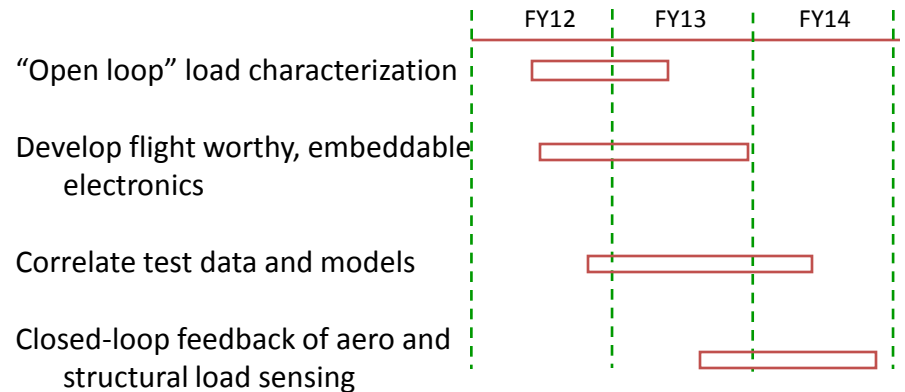

Collaborators

Collaborator	FY12	FY13	FY14
AFRL/RB	\$2M	\$2M	\$1M
NASA	\$2M	\$2M	\$2M



Real-time Aerodynamic and Structural Sensing for Controlling Aeroelastic Loads (RASSCAL)

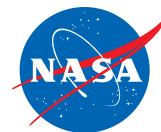

Current status of flexible arrays

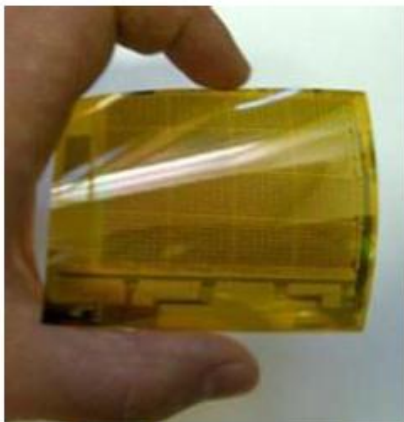

μ C-Si 32x 32 array on polyimide

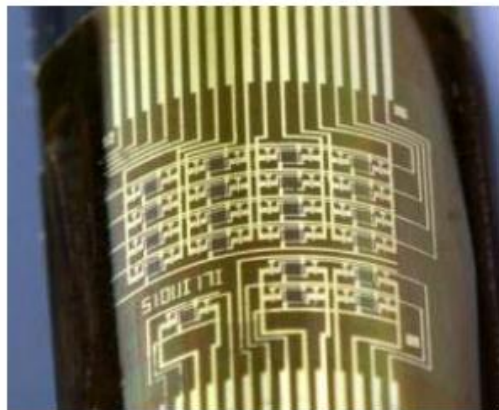

Single-C-Si 4x4 arrays

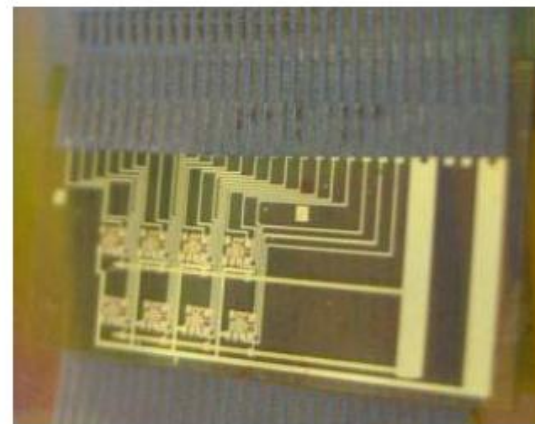

Integration of dissimilar devices

Metric	Target Value	Actual Value
(1) Strain range	4000 $\mu\epsilon$ – 6000 $\mu\epsilon$	Discretes linear 7000 $\mu\epsilon$; 4x4 arrays shown repeatedly to at least 2000 $\mu\epsilon$.
(2) Operational temperature	-54°C to 190°C (-65°F to 375°F) (Typical fighter class aircraft, top level structural requirements include -54°C to 121°C (-65°F to 250°F) skin temperature [†])	Strain sensors have demonstrated in excess of skin temperature range (-65 to 160°C); Differential amplifiers demonstrated to 80°C but failed at 90 °C.
(3) Gage factor	Minimum 24	Gage factors range from 20 to 65, significantly dependent on processing.
(4) Response	Frequency response in millisecond range	Average 0.6ms time constant, -3dB cutoff frequency: 270Hz
(5) Gage dimensions	<1 mm in area	Tested discrete sensors with gage area from 0.11mm ² to 7.2mm ² ; sensors in arrays have 0.11mm ² area.
(6) Fatigue life	1 lifetime (i.e., 6000 hours) for fighter aircraft applications ^{††}	Demonstrated functionality exceeding 132,000 tension/compression cycles for discrete sensors. Surpassed 126,000 as in S ³ TD F-18 case.



RASSCAL \leftrightarrow Fly-by-Feel



“Fly-by-Feel” is an expansion of ISHM through active sensing of the flight environment.

Why do we want fly-by-feel?

- Vastly improved empirical models for control and analytical modeling for design
- Exploitation of phenomena that can't be analyzed accurately (such as stall for perching)
- Aerodynamic, structural, and control efficiency increase
- Reduction in factors of safety (due to load uncertainty)
- Reduction in air vehicle certification time and cost

What is needed to enable fly-by-feel?

- Structurally embedded sensors, traces, and active chips
 - Minimize sensor protrusion into air flow
 - Minimize impact on structural performance
 - Improve reliability of sensors and associated electronics
 - Minimize trace count, length, weight, and power requirements
 - Minimize ingress/egress issues
- Efficient means of processing sensor data
 - Identification of “critical points” for characterization of aerodynamics and airframe response
 - Switching and multiplexing algorithms
 - Understanding how to use new sensors and parameters in controllers
- Efficient means of manufacturing multifunctional structure
 - Direct Write, Laser Transfer, etc
 - Sensor and trace consistency

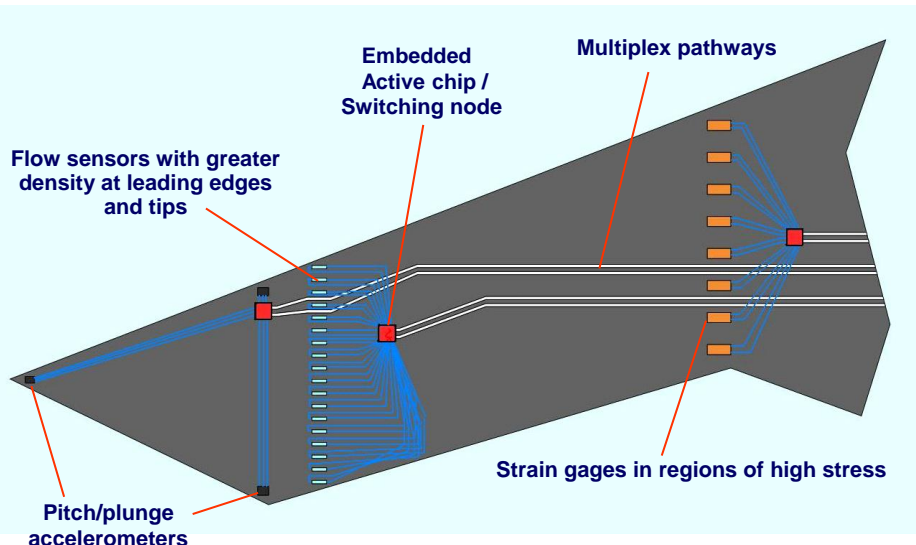



BY GUY NORRIS

San Diego, California
 Bureau Chief, Guy Norris Mags
 at: AviationWeek.com
 guy_norris@peterdinklage.com



COMMENTARY

Fly-by-Feel

Lightweight, flexible-structures project could bridge gap to practical adaptive aircraft

Since the advent of powered flight, aircraft designers have sought to escape the bondage of heavy rigid structures by moving to lighter, bird-like adaptive shaping and sensing technology.

Such advances potentially offer dramatic improvements in performance and safety, allowing designers to reduce load margins

and enabling the aircraft to react swiftly to changes. While the theoretical benefits of adaptive aircraft have long been known, and dramatic damage tolerance demonstrations using sub-scale F-18

models have proven the concept's viability, more needs to be done to make it a practical prospect. With this in mind, NASA is planning a lightweight, flexible-structures research program that could build on previous basic research efforts to demonstrate "fly-by-feel" sensing and control technology on a modified F-18. Researchers believe the demonstration will boost technology readiness levels toward real-world applications of lighter commercial and military designs.

As part of the continuing development of lightweight structures, the U.S. Air Force Research Laboratory is also discussing joining the initiative. "We've been talking to them, and they're very interested in trying to put together some collaborative effort in the future," says Mark Dickerson, program manager for Model Reference Adaptive Control (MRAC) at NASA Dryden Flight Research Center.

The MRAC F-18 is fitted with a simplified adaptive controller that compensates for simulated failures of flight control surfaces. Using MRAC as a springboard, NASA believes it



could take the concept much further. "The ultimate idea is to put a system in service on an aircraft that can sense the structure and things that are happening to the aircraft, and use that information and force it into a shape that it would like it to be," says Dickerson. "The side benefit is that if it can sense shape, it can also control it in case of a failure. Load-sensing can help you cut back on load margins, so you can have a lightweight structure that is active."

A subset of NASA's Aviation Safety Program's Vehicle Safety System effort, MRAC builds on earlier attempts including the F-16 Intelligent Flight Control System (IFCS), and the follow-on F-18 Full-Scale Advanced Systems Technology (FAST). "The current adaptive control comprises less complex systems and algorithms that could be more easily modified for commercial use in the future, when new technologies are fully validated and verified," says Dickerson.

"We're using much simpler algorithms than in the IFCS. We sort of dumbbed it down if you will," says Jim

Lee, MRAC project chief engineer. "The system does not have all the load buds in it [as in the IFCS], it is simplified to something that will enable conventional processors to be used, and that can be shown to be safe in a commercial application."

Earlier projects included a Rockwell Collins and Defense Advanced Research Projects Agency system, which proved that a catastrophically damaged unmanned F-18 sub-scale model air vehicle with an adaptive control system could safely land. "That program showed you can design the algorithms to control a severely damaged aircraft, but the problem is getting it certified in the real world. We feel like NASA has the clout to work on a full-scale vehicle to help this process," says former IPCS chief engineer John Bosworth.

Following the end of MRAC flights and a final contract buyup, the F-18 will be fitted with fiber optic wing shape sensors to provide real-time measurement and feedback to the flight-control system. This comprises the baseline F-18 system, a ground-redundant research flight control system developed for the FAST effort, as well as a dual-redundant airborne research test system—ARTS IV—which provides a way of rapidly testing new concepts. In addition, the system will be linked to 200 strain gauges that remain on the flight-control surfaces from the Active Aeroelastic Wing research program, which tested the concept of using lighter-weight wings and wing twist for enhanced aircraft roll control.

Although fiber-optic sensors have flown on composite-built unmanned air vehicles, none have so far been tested in a rigid, conventional airframe. "The F-18 has a stiff wing, with a complex structure. This is a 'real' aircraft with lots of panels," says lead controls engineer Ryan Dibley. Initial flight tests of the modified F-18s are set to begin in December 2011.

Precise sensing technology, along with detecting flow singularity, paves the way for active control, says Bosworth. "Rather than controlling it by angle of attack, the next step is novel ways of controlling flow across the wing via nano devices and active flow." ☐



ASE Sensor Applications: X-56A

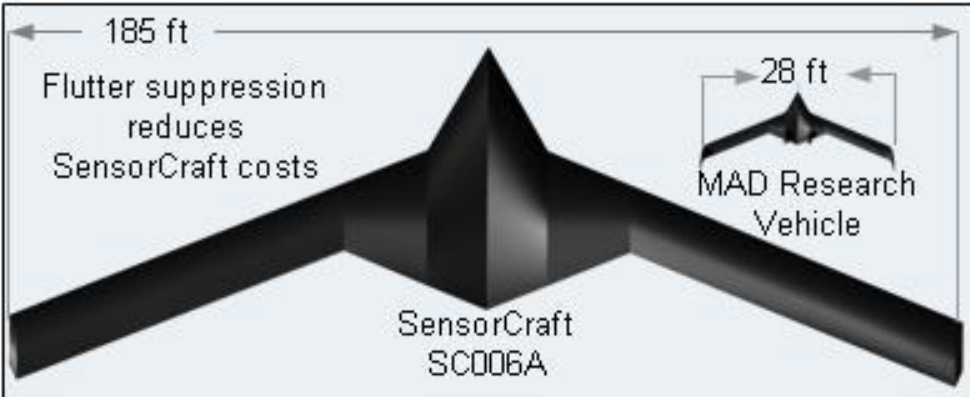
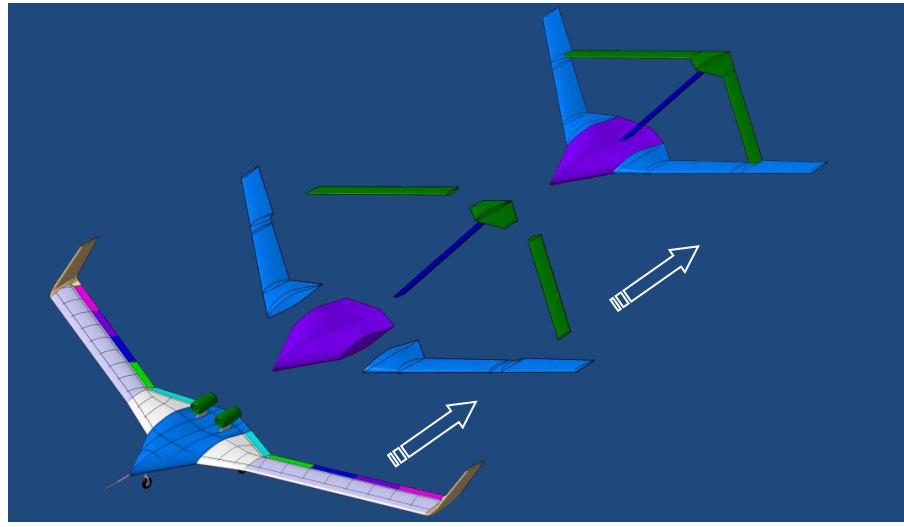
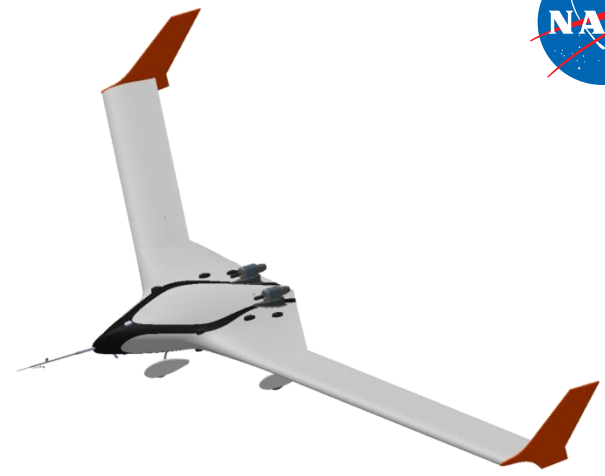



Fiber Optic Strain Sensing (FOSS) Technology

Development: Advantages over Conventional Sensors

- Unrivaled density of sensors for spatially distributed measurements
- Measurements immune to EMI, RFI and radiation
- Lightweight, Small fiber diameter
- Can determine out-of-plane displacement and load at points along the fiber
- Single calibration value for an entire lot of fiber
- Wide temperature range (cryogenic – 550F)

- Develop small, lightweight multipurpose system
 - Support small UAVs platforms
 - Support more aggressive manned vehicles like NASA's 853 (F-18)
 - Support launch vehicles and space applications
 - Robust thermal management

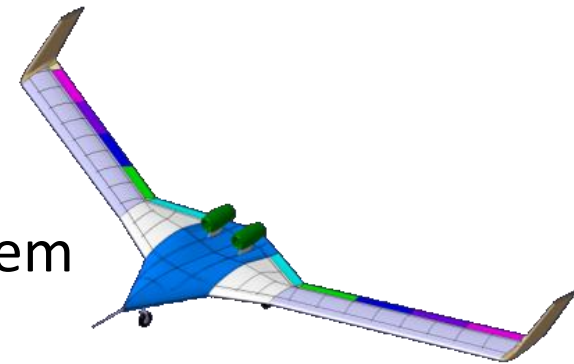

Wires for 21 strain gage measurements

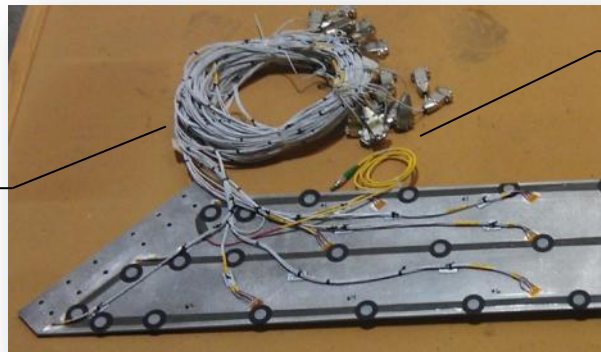

Fiber for 628 FOSS sensors

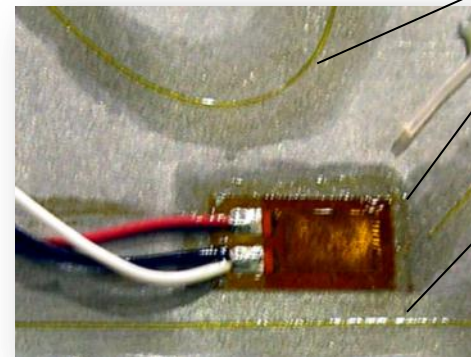

Fiber optic sensor

Strain gage

Fiber optic sensor

FOSS Technology Development: Multi-Utility Technology Testbed (MUTT = X-56A)

Goal: robust data, model-independent AE control applications

- Control of flexible structures is critical (SFW, SUP, etc)
- Available for ground and flight testing with detailed models
- Interchangeable wings and low operating costs
- Structure representative of larger aircraft
- Risk-tolerant step towards larger aircraft

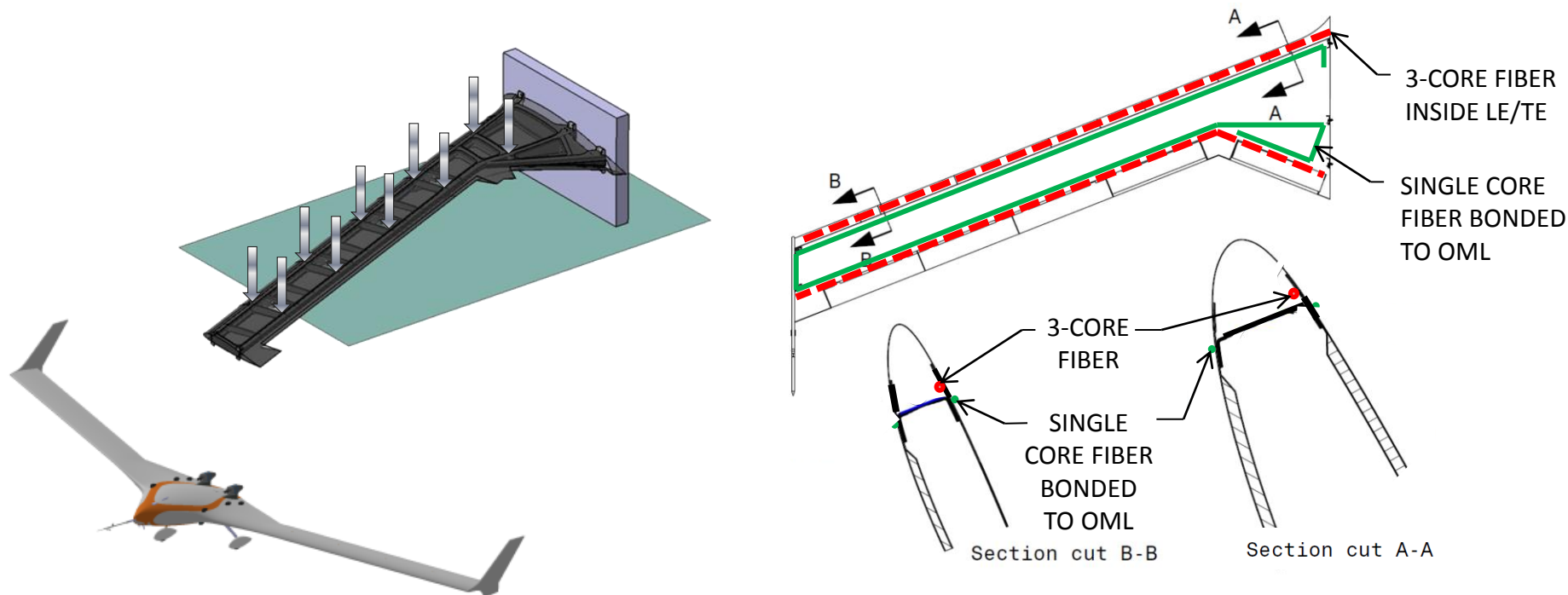



Full-Scale Advanced System Testbed (FAST) F18 Flight Research LESP and SBLI Aero Sensing

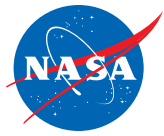

Aero Sensing LESP / SBLI Flight Evaluation

- Assess suitability of Leading Edge Stagnation Point (LESP) and SBLI sensing system for subsonic-to-supersonic aeroelastic modeling and control with external disturbances

Scope

Sensor characterization of Leading Edge Stagnation Point (LESP) sensor technology with unsteady pressures, shock, and control surfaces

- Help develop ASE and gust load alleviation control laws
- Steady and unsteady FBP and pressure measurements
- Evaluate LESP with shock location and surface position/rate
- LESP with SBLI measurements across all flight regimes
- Flight near aero-sensitive regions (high-alpha, stall, STOL)

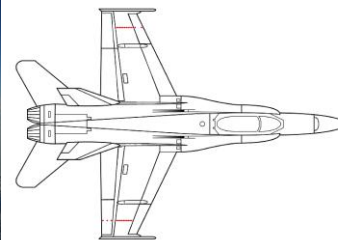

FAST-F18 ASE Flight Research

Unsteady Tran-to-Supersonic Flow over a Transport-Type Swept Wing

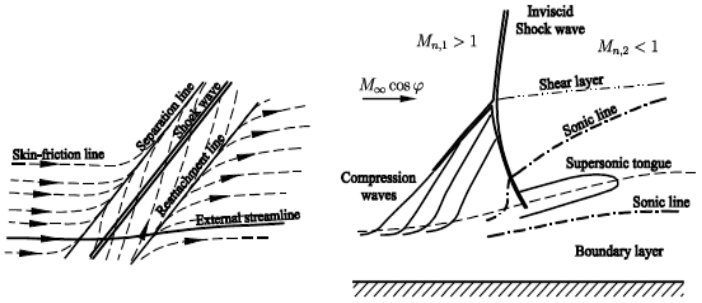

RWTH Aachen University - Institute of Aerodynamics

- “Weak shock/boundary-layer interaction with incipient separation has minor effects on the wing structure, despite the occurrence of large pressure *fluctuations*, whereas the strong interaction involving shock-induced separation results not only in significantly *weaker fluctuations* in the pressure field, but also in a strong fluid–structure coupling.”
 - Aerodynamic forces increase strongly with speed, elastic/inertia forces unchanged => “transonic dip”, then rising flutter stability limit from ***separated flow acting as aero damping***
 - Lightweight with optimal wing geometries => steady/unsteady aero-wing behavior critical
 - Periodic shock oscillation due to the ***acoustic feedback loop*** is not induced by the onset of dynamic fluid–structure interaction ***but it can excite a structural unsteadiness wrt phase lags***
 - ***Shock-induced*** separation of the turbulent boundary layer occurs without reattachment which indicates the performance boundary
- Aero-wing relative phase results in SBLI with unsteady frequencies
- Not wing flutter, but a pure response to the distinct oscillation of the flowfield and the shock wave **with Re (scale) dependence**

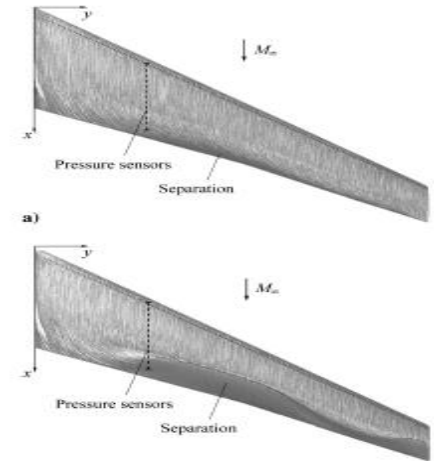

Table 3 Overview of flow test cases for AA-PSP measurements

	Condition 1	Condition 3
Shock/boundary-layer interaction	Weak	Strong
Type of separation	Small trailing-edge separation	Shock-induced separation without reattachment
Unsteadiness	High degree in entire flowfield	Lower, harmonic shock oscillation
Reduced fundamental frequency	$\omega^* = 0.73$	$\omega^* = 0.72$

Object-Oriented MDAO tool Development



Problem

- Reduce the structural weight further down than current technology can take care of, we need to develop a new innovative structural design concept
- Global optimizer, Genetic Algorithm (GA), in the current MDAO tool requires too much iteration to have a reasonable solution
- A global optimizer is needed for topology optimization with curvilinear sparibs and sizing optimization with discrete design variables (DDV)

Proposed solution

- Use aeroelastic tailoring based on composite material as well as curvilinear sparibs concept together with an active flexible motion control technique
- Use Big Bang-Big Crunch (BBBC) algorithm as a global optimizer

Approach

- ❑ DFRC Object-Oriented Optimization (O³) tool
 - ❖ The O³ tool leverages existing tools and practices, and allows the easy integration and adoption of new state-of-the-art software
 - ❖ Local gradient based optimizer as well as global optimizers are available. Hybrid methods are also available
 - Optimizers: DOT (local), Genetic Algorithm (GA), & BBBC algorithm
 - Hybrid optimizers

Object-Oriented Optimization Tool

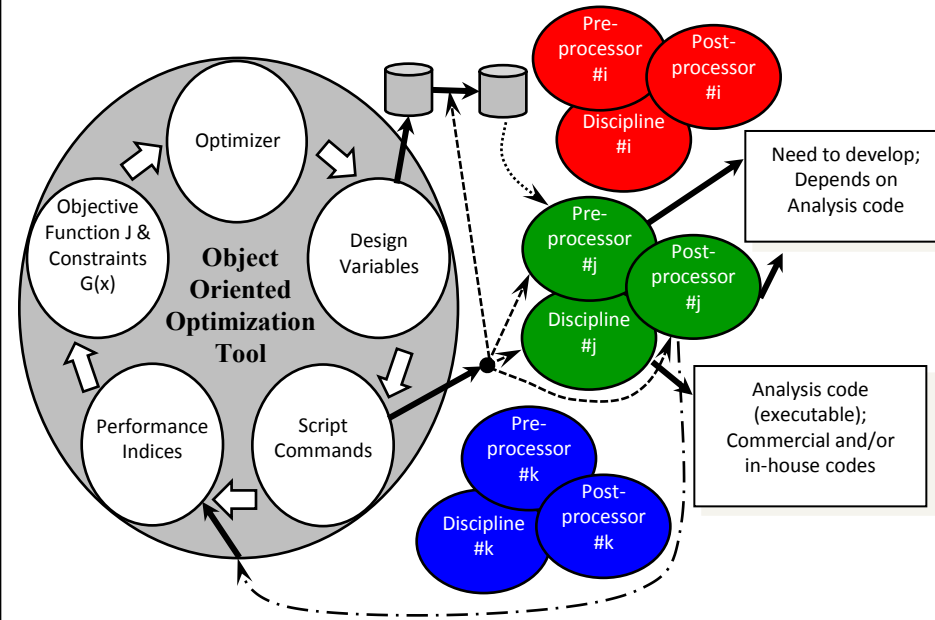

Approach(continued)

- ❑ Develop multilayer, multifidelity, & multidisciplinary design, analysis, & optimization tool using O³ tool
 - ❖ Inner-layer: mainly for structure and control design
 - ❖ Outer-layer: mainly for aerodynamic design
- ❑ Incorporate the following analysis modules
 - ❖ weight, stress/strain, buckling, open & closed-loop flutter, gain/phase margin, maneuver load alleviation, & automatic mesh generation for curvilinear sparibs
 - ❖ lift/drag, gust, & sonic-boom
 - ❖ internal noise & etc

Aeroservoelastic MDAO Model Validation



Application (X-56A)

- ❑ Finite Element Model Tuning of X-56A Aircraft using Parallelized Big Bang Big Crunch Algorithm
 - ❖ The primary objective of this study is to reduce uncertainties in the structural dynamic finite element model of an aircraft to increase the safety of flight.
 - ❖ This model tuning technique is applied to improve the flutter prediction of the X-56A aircraft.
 - ❖ This work is supported by ARMD SFW and SUP projects under FA program.
 - ❖ Deliverables: finite element model for MSC/NASTRAN simulation
- ❑ Unsteady aerodynamic model tuning of X-56A Aircraft based on indirect method
 - ❖ An automatic aerodynamic mesh generation code is under development.
 - ❖ Deliverables: unsteady aerodynamic model for ZAERO simulation and paper/report
- ❑ Create Reduced Order X-56A Aircraft Structural Dynamic Model
 - ❖ Use Equivalent Beam Model
 - ❖ Create target frequencies and mode shapes using full-3D FE model
 - ❖ Use Structural dynamic model tuning code
 - ❖ Deliverables: finite element model for MSC/NASTRAN simulation

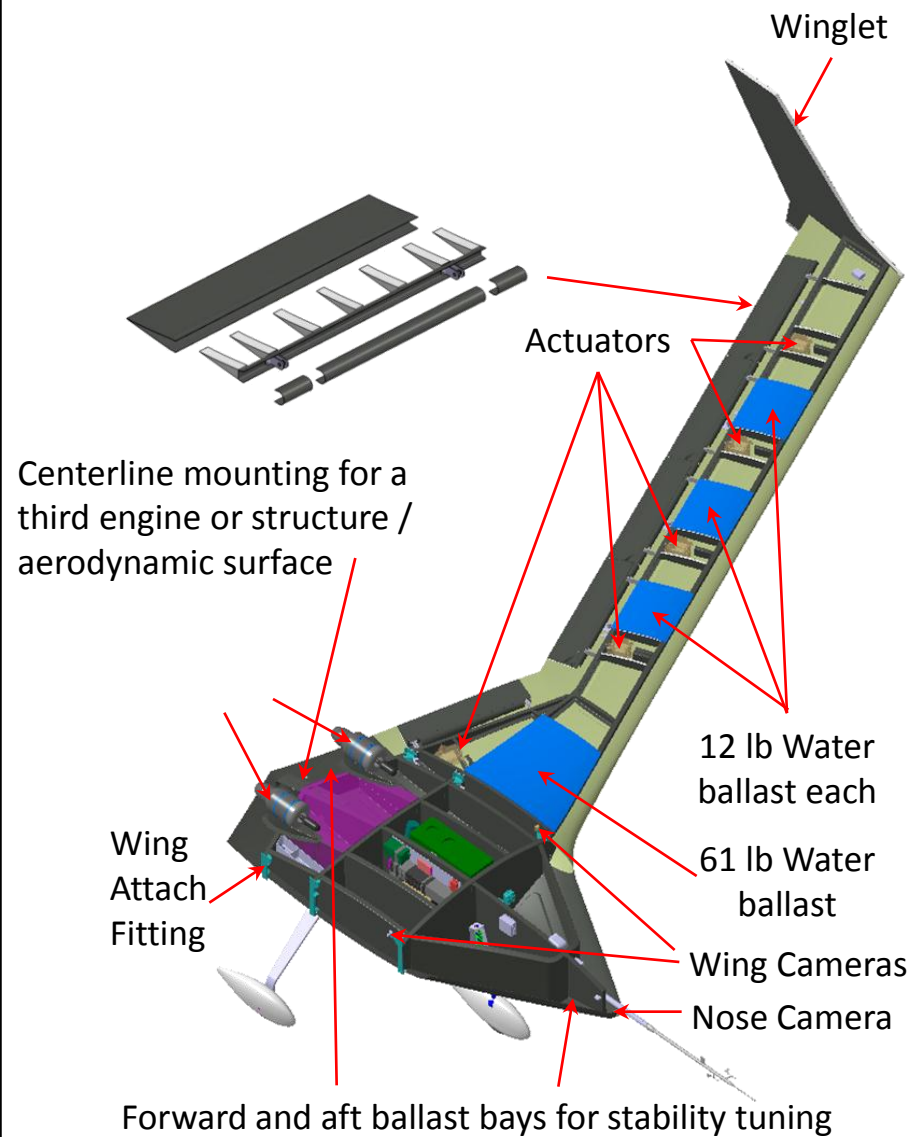

Aeroservoelastically Tailored Wings and Aircraft

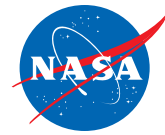

Design Approaches

- Simultaneously update structural as well as control design variables during early design phase
 - Perform topology optimization with curvilinear sparibs
 - Use aeroelastic tailoring up to V_d line
 - Use aeroservoelastic tailoring between V_d and $1.15 V_d$

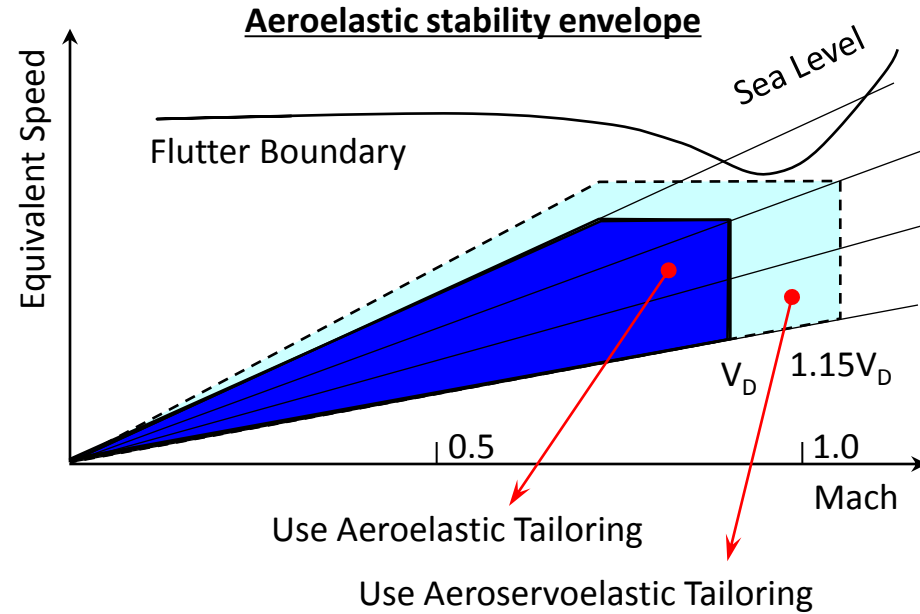
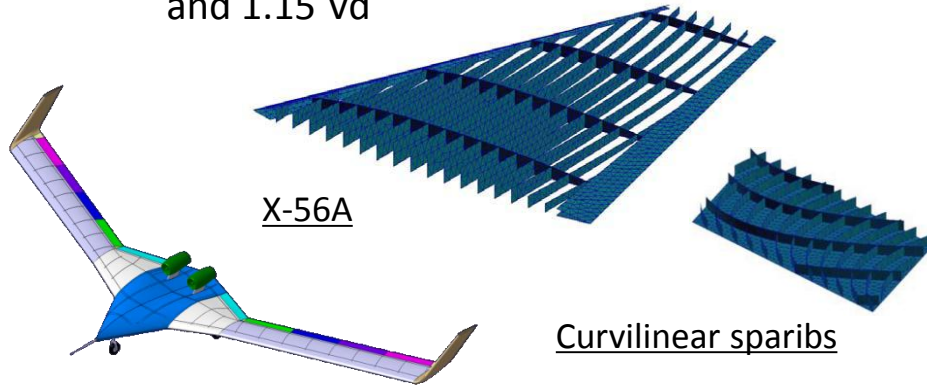

Future Applications

- N+3 Concept Aircrafts for Fixed Wing and High Speed Aircrafts; ERA

Deliverables

- Finite element structural models for preliminary and detailed design, papers, & reports

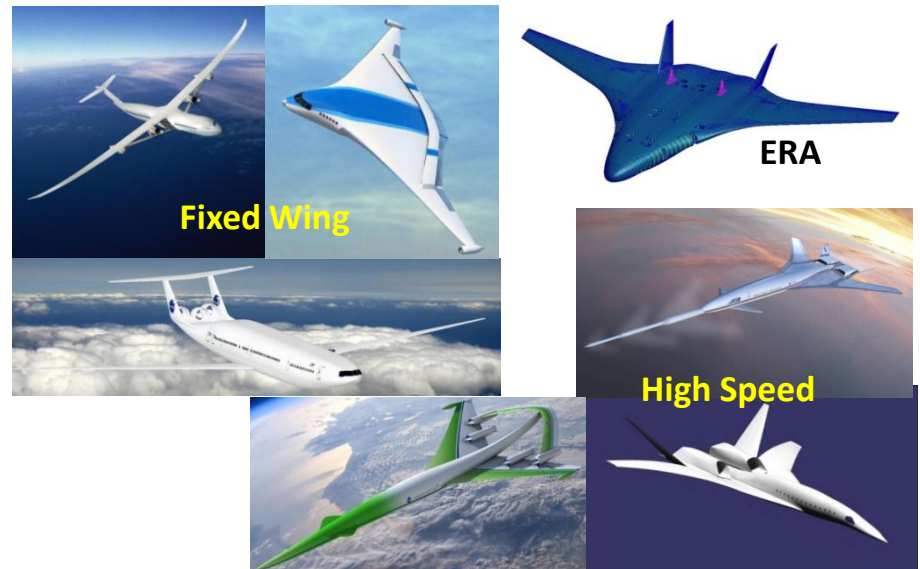



Flexible Motion Controls with ASE System Uncertainties

Problem

- The increased flexibility, due to weight reduction, creates an aircraft that is more susceptible to aeroelastic phenomena such as flutter, divergence, buzz, buffet, and gust response.
 - Uncertainties exist in aeroservoelastic system even with the test validated aeroservoelastic model due to
 - time-varying uncertain flight conditions,
 - transient and nonlinear unsteady aerodynamics and aeroelastic dynamic environments.

Proposed solution

- Use Active/Adaptive Flexible Motion Control
- An adaptive “delta control” methodology is proposed.
 - On-line parameter estimation will be applied to the prediction error, uncertainties in the validated aeroservoelastic model.

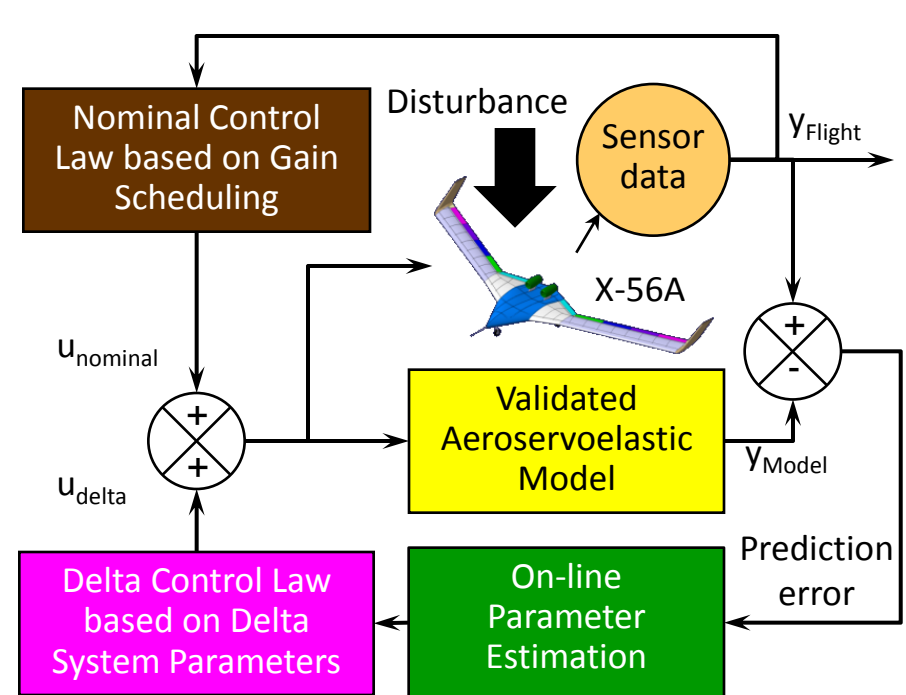

Approach

- The online update for the delta control gain is determined on the basis of a test-validated aircraft model whose predicted output response is compared with the actual aircraft measurements.
- The delta control scheme will act in addition to a nominal control law developed solely from the test-validated model so has to help offset some of the model's inaccuracies and uncertainties.

Assumptions & Limitations

- Dynamically linear assumption will be used for the prediction error model.
- On-board computer should be powerful enough to perform on-line estimation and control law updates.



ASE Maneuvering Simulation Development

STATUS QUO

- Integration of ASE dynamics of the F18-853 aircraft into the NASA Dryden simulation
- AAW models and flight data used for full-envelope flight dynamics simulation



NEW INSIGHTS

- Aeroelastic effects becoming more essential for accurate flight dynamics modeling
- Integration of aeroelastic with flight dynamics requires multirate integration with proper rigid-elastic-controls coupling and aeroelastic model interpolation schemes

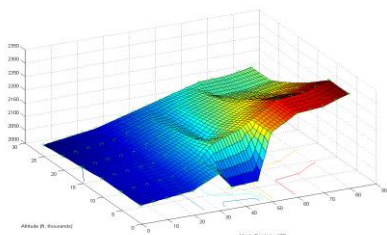

PROBLEM / NEED BEING ADDRESSED

Maneuvering simulation of general aircraft aeroservoelastic dynamics with reduced-order state-consistent models

PROGRAM DESCRIPTION:

Development of aeroservoelastic maneuvering simulation facility with efficient and direct implementation of multi-fidelity models for general active/adaptive and distributed sensing control architectures

- Challenges
 - Appropriate state-space representations of flight dynamics with aeroelastic interactions and general multi-disciplinary components
 - Multi-rate synchronization of various disciplines into multidisciplinary environment for maneuvering flight
 - Real-time accuracy with sufficient fidelity
- ARMD Program Goals
 - FAP: Improved Comp/Exp Tools & Methods, System Integration, MDAO Simulations
 - AvSP: Aircraft Loss of Control Prevention, Mitigation, and Recovery (LOC) Analysis

Integration of complex modeling and controls in real-time flight environment

QUANTITATIVE IMPACT

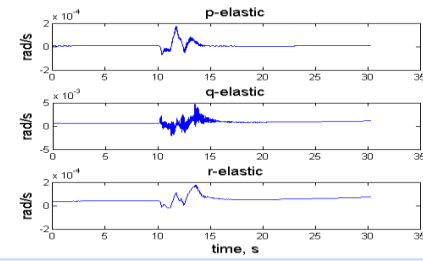

- Verification of implementation
- Additional flight data over the flight envelope will ensure more accurate ASE characterizations
- Analysis of novel distributed sensing and control schemes



PROGRAM GOAL



- ASE integration framework with the NASA Dryden F/A-18 simulator is established
- Proven process should simplify integration in support of the development of ASE models for other flight test programs
- Provides a basis for future flight research endeavors in distributed sensing and controls

Modular Architecture for Distributed Autonomous Aerospace Systems

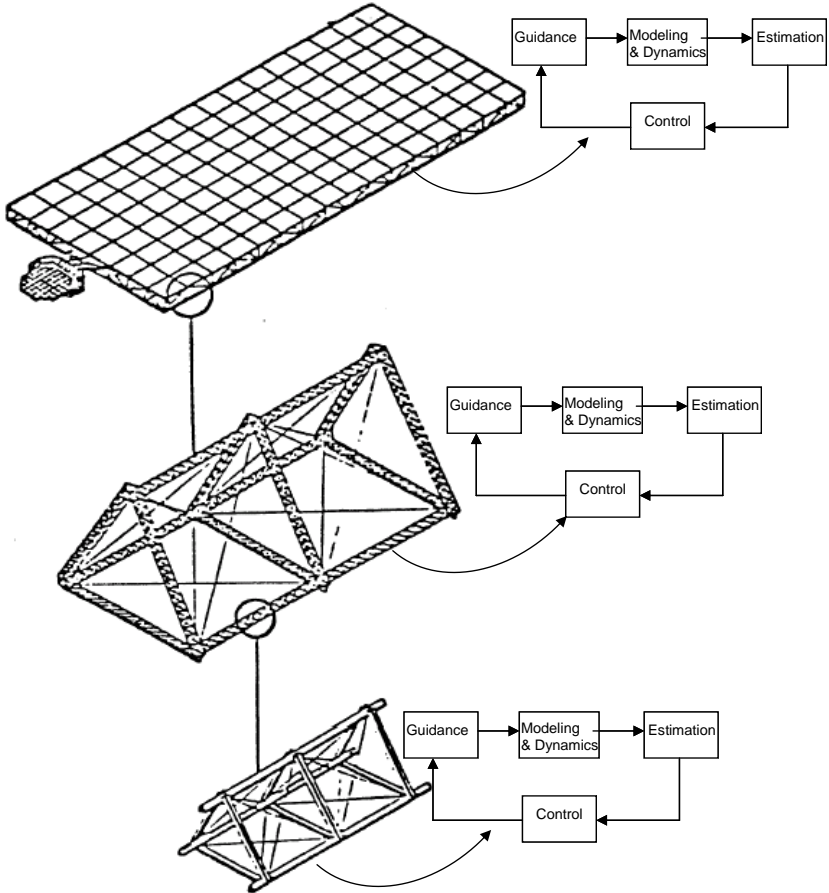
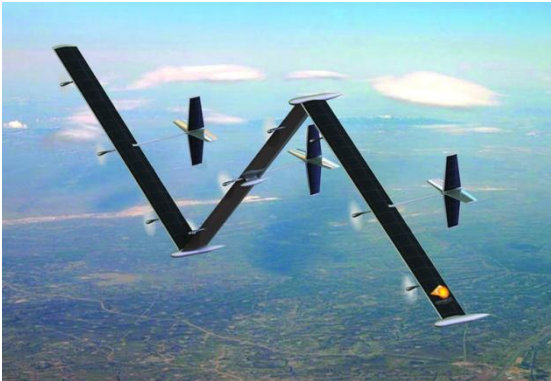

Modular Architecture for Distributed Autonomous Aerospace Systems (Summary Slide)



Persistent, atmospheric aerial coverage for planetary exploration

- detailed science data gathering, e.g., planetary surface, atmospheric
- terrestrial/aerial/satellite network to support human habitation or entry/descent/landing of other vehicles, auto rendezvous/docking

Modular architecture for distributed, autonomous aerospace systems

- enables separate but dynamically integrated sub-systems, where faults are distributed and dynamically re-allocable, increases mission duration

Applies to aeronautics (lightweight, disturbances, aerostructural) and space

Evolving systems as applied to self-assembling systems, robotic maneuvering

- designing control systems with strict passivity/dissipativity
- ensure reliability, coordination and **mission adaptivity**
- **adaptive** communication and control **network topology**

Multi-objective, multi-level control and estimation architectures

- **decentralization** with information-based sensing for comm&control
- **consensus-coordination** using multi-agent systems (behavioral)

Phase 1: Identify modular UAV design, control architecture, metrics evaluation

OCT Roadmap&Priorities:

Provides capabilities that would enable new projects/missions that are not currently feasible during the next 10-20 years

Impacts multiple missions in NASA space operations and science, earth science, and aeronautics

Influential across aerospace and non-aerospace communities

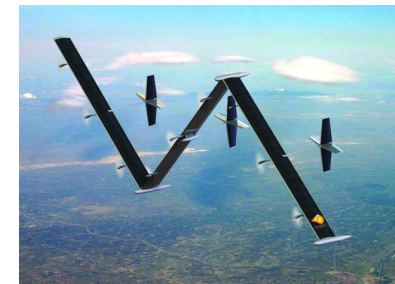
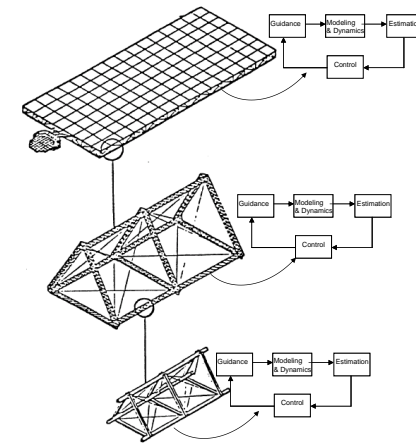

PI – Martin Brenner, DFRC
Partners (academia, NASA, SBCs):

Prof. Mark Balas, Dept Head ECE, UofWyo
Dr. Susan Frost, NASA Ames
Tao Systems Inc.