

Satellite Gravimetry Applied to Drought Monitoring

A book chapter submitted to Taylor and Francis

28 June 2010

first revision 20 August 2010

second revision 8 December 2010

third revision 23 February 2010

by

Matthew Rodell

Hydrological Sciences Branch, Code 614.3

NASA Goddard Space Flight Center

Greenbelt, MD 20771

Matthew.Rodell@nasa.gov

301-286-9143

I. Introduction

Near-surface wetness conditions change rapidly with the weather, which limits their usefulness as drought indicators. Deeper stores of water, including root-zone soil wetness and groundwater, portend longer-term weather trends and climate variations, thus they are well suited for quantifying droughts. However, the existing *in situ* networks for monitoring these variables suffer from significant discontinuities (short records and spatial undersampling), as well as the inherent human and mechanical errors associated with the soil moisture and groundwater observation. Remote sensing is a promising alternative, but standard remote sensors, which measure various wavelengths of light emitted or reflected from Earth's surface and atmosphere, can only directly detect wetness conditions within the first few centimeters of the land's surface. Such sensors include the Advanced Microwave Scanning Radiometer - Earth Observing System (AMSR-E) C-band passive microwave measurement system on the National Aeronautic and Space Administration's (NASA) Aqua satellite, and the combined active and passive L-band microwave system currently under development for NASA's planned Soil Moisture Active Passive (SMAP) satellite mission. These instruments are sensitive to water as deep as the top 2 cm and 5 cm of the soil column, respectively, with the specific depth depending on vegetation cover. Thermal infrared (TIR) imaging has been used to infer water stored in the full root zone, with limitations: auxiliary information including soil grain size is required, the TIR temperature versus soil water content curve becomes flat as wetness increases, and dense vegetation and cloud cover impede measurement. Numerical models of land surface hydrology are another potential solution, but the quality of output from such models is limited by errors in the input data and tradeoffs between model realism and computational efficiency.

Water mass has a gravitational potential which when integrated over a large enough area, can be great enough to alter the orbits of satellites. If those orbits are tracked precisely enough, the information can be used to infer redistributions of water both on and below the land surface regardless of depth. The capability to assess both surface and sub-surface changes in water is one of the primary rationales for satellite missions dedicated to the measurement of Earth's time variable gravity field. The Gravity Recovery and Climate Experiment (GRACE) is the first such mission. Launched in 2002, GRACE has already proved to be a game changer in the field of global hydrology. Pilot projects are now demonstrating how GRACE derived terrestrial water storage data can be downscaled and enhanced by integrating them with other data within sophisticated numerical land surface models, and how the resulting fields of groundwater and soil moisture can be applied for drought monitoring.

This chapter is divided into eight sections, the next of which describes the theory behind satellite gravimetry. Following that is a summary of the GRACE mission and how hydrological information is gleaned from its gravity products. The fourth section provides examples of hydrological science enabled by GRACE. The fifth and sixth sections list the challenging aspects of GRACE derived hydrology data and how they are being overcome, including the use of data assimilation. The seventh section describes recent progress in applying GRACE for drought monitoring, including the development of new soil moisture and drought indicator products, and that is followed by a discussion of future prospects in satellite gravimetry based drought monitoring.

II. Satellite Gravimetry

The gravitational force experienced at the Earth's surface varies in space and time, so that the gravity field of the whole Earth takes the form of a not-quite-smooth ellipsoid. It is said to have both static and time variable components. The static components are orders of magnitude stronger and include the total mass of the Earth and mass heterogeneities that only vary on geologic time scales, such as the distribution of the continents and the locations of mountain ranges and depressions in the crust (e.g., Dickey et al., 1997). Jeffreys (1952) was among the first to report the existence of the time variable component of the gravity field, noting that mass movements such as ocean tides changed gravitational potential. At that time, spatial variations in the gravity field were observed primarily with the aid of pendulums.

Mapping spatial heterogeneities in the Earth's gravity field was facilitated by the first artificial satellites, including Vanguard 1 and ANNA 1B, which began orbiting in the late 1950s and early 1960s. Satellite tracking via optical and Doppler techniques allowed scientists to compute departures from predicted orbits, and these departures were attributed to previously unobserved factors affecting the paths of the satellites, irregularities in the static gravity field in particular. In the 1980s and 1990s, orbit determination was accomplished by ground-to-satellite laser ranging (e.g., Yoder et al., 1983), which afforded more detailed assessments of the gravity field. Gutierrez and Wilson (1987) confirmed that perturbations in the orbits of the Lageos and Starlette satellites were caused by seasonal patterns in the distribution of atmospheric mass and water stored on the continents. Chao and O'Connor (1988) reached a similar conclusion in their study of the effects of seasonal changes in surface water on the Earth's rotation, length of day, and gravity field. Dickey et al. (1997) performed a comprehensive study of the potential benefits to hydrology and other disciplines of a dedicated satellite gravimetry mission designed to

observe the time variable component of Earth's gravity field, and explored possible mission scenarios. Based in part on the recommendations of that study, NASA provided funding to develop a mission that would later be named the Gravity Recovery and Climate Experiment or GRACE.

III. The Gravity Recovery and Climate Experiment

GRACE, jointly operated by NASA and the German Aerospace Center, launched on March 17, 2002 and has continued to perform past its nominal mission lifetime of five years. It consists of two satellites in a tandem orbit about 200 km apart at 450-500 km altitude (Figure 1). A K-band microwave tracking system continuously measures changes in the distance between the satellites caused by heterogeneities in the gravity field, with a precision of better than 1 micrometer (Tapley et al., 2004). Non-gravitational accelerations are monitored by onboard accelerometers, and the precise positions of the satellites are fixed via global positioning system (GPS).

Each month, those measurements are used to produce a mathematical representation of the global gravity field, as a set of coefficients (degree and order ≤ 120) to a spherical harmonic expansion that describes the shape of the geoid (the surface of constant gravitational potential best matching the mean sea surface). The expansion coefficients can be manipulated using numerical devices such as Gaussian averaging functions in order to isolate mass anomalies (deviations from the baseline temporal mean) over regions of interest (e.g., Wahr et al., 1998). Errors in such estimates are inversely related to the size of the region, being as small as 1-2 cm equivalent height of water over continental-scale river basins, and being large enough to overwhelm the hydrology signal as the area drops below $\sim 150,000 \text{ km}^2$ (Wahr et al., 2006). As an alternative to

the spherical harmonic technique, the inter-satellite ranging data can also be used directly to estimate regional "mass concentrations" without the need to first derive a global gravity field (Rowlands et al., 2005).

The main drivers of temporal variations in the gravity field are oceanic and atmospheric circulations and redistribution of terrestrial water via the hydrological cycle. By accounting for the first two using analysis models (another error source), GRACE scientists quantify anomalies in terrestrial water storage (TWS), which is the sum of groundwater, soil moisture, surface water, snow, ice, and vegetation biomass. Glacial isostatic adjustment also must be considered in certain regions such as Hudson's Bay in Canada, and a major earthquake can produce a significant gravitational anomaly, but the timescales of most solid earth processes are too long to be an issue.

IV. Hydrological Science Enabled by GRACE

GRACE was designed as a geodesy mission, but it has supported many advances in water cycle science. Among the early results, Tapley et al. (2004) and Wahr et al. (2004) presented the first satellite-based estimates of column-integrated TWS variations at continental scales. Rodell et al. (2004) and Swenson and Wahr (2006) took advantage of the fact that TWS change (ΔTWS) is a component of the terrestrial water budget equation, and demonstrated the estimation of evapotranspiration (ET) and atmospheric moisture convergence (MC), respectively, over large river basins as residuals of observation-based water budget analyses using the following equations:

$$ET = P - Q - \Delta TWS \quad (1)$$

$$MC = P - ET = Q + \Delta TWS \quad (2)$$

where P and Q are total precipitation and net stream flow over a specified time period. Equation 2 ignores atmospheric water storage changes and horizontal transport of condensed water, which are normally much smaller than the other variables. As described in those papers, the actual calculations are somewhat more complicated due to the time averaged nature of the GRACE observations. Syed et al. (2005) used a similar approach to estimate monthly discharge from the Amazon and Mississippi Rivers:

$$Q = MC - \Delta TWS \quad (3)$$

where MC is provided by an atmospheric analysis model.

One of the most valuable applications of GRACE has been accurate monitoring of mass loss from the Greenland and Antarctic ice sheets (e.g., Velicogna and Wahr, 2005 & 2006; Luthcke et al., 2006; Ramillien et al., 2006). Likewise, Tamisiea et al. (2005) and Luthcke et al. (2008) showed that melt water from glaciers in southern Alaska contributes significantly to sea level rise.

GRACE continues to spawn innovative science. Crowley et al. (2006) used GRACE to confirm the previously hypothesized anti-correlation of interannual TWS variations on opposite sides of the southern Atlantic, such that droughts in the Amazon tend to be coincident with pluvials in the Congo River basin, and vice versa. Rodell and Famiglietti (2002), Yeh et al. (2006), and Rodell et al. (2007) described how GRACE could be used with ancillary information to generate time series of regionally averaged groundwater storage variations. Rodell et al. (2009) and Tiwari et al. (2009) later applied the technique to quantify massive groundwater depletion in northern

India due to withdrawals for irrigation. Han et al. (2009) used a similar method to isolate surface water storage variations in the Amazon. Swenson (2010) evaluated satellite-derived precipitation products at high latitudes, where data for validation are scarce, using GRACE-derived time series of winter snow load. The potential for combining GRACE observations with data from other Earth observing missions is only just beginning to be realized. Current examples include detailed ice sheet monitoring through the combination of ICESAT and GRACE data, and terrestrial water budget studies that utilize satellite observations (Rodell et al., 2004; Sheffield et al., 2009). Future prospects include synthesis of GRACE TWS data with high resolution soil moisture observations from SMAP, which may enable more detailed drought assessments building on the data assimilation based approach described in section VII.

V. Unique and Challenging Aspects of GRACE Data

The key to GRACE's success in delivering valuable hydrological data is its unique ability to measure changes in water stored at all levels on and beneath Earth's surface. Downward looking satellite remote sensors are limited by the depth of penetration of the measured light (visible, microwave, or otherwise), which is typically a few centimeters into the soil or perhaps a meter into the snowpack. Clouds, vegetation, and radio frequency interference can also be problematic. Because GRACE senses water through the orbital response of its two satellites to gravitational perturbations, it has no such limitations.

However, applying satellite gravimetry data for hydrology can be challenging. First, while remote sensing retrievals are always impacted by mixed signals and indirect sensing of the variable of interest, most Earth observing systems ultimately are able to distinguish individual

variables, such as snow cover, soil moisture, or surface elevation and deliver such specific products. Gravimetry-based TWS information, on the other hand, convolves changes in groundwater, soil water in all layers, surface water, snow, ice, and vegetation biomass into one integrated quantity. Second, an individual GRACE observation provides no indication of the absolute quantity of water stored in and on the land. It must be considered in relation to previous observations in order to discern relative changes or anomalies of water storage. In contrast, SMAP is expected to deliver instantaneous estimates of the moisture content of the upper soil. Third, the spatial resolution of GRACE, which is about 150,000 km² at best (Rowlands et al., 2005; Swenson et al., 2006), is orders of magnitude coarser than most other satellite-based Earth observations. Future gravimetry missions may improve on this, but they are unlikely to approach the resolutions of optical (e.g., Landsat) and microwave (e.g., AMSR-E) remote sensors, which are on the order of meters and tens of kilometers, respectively. Fourth, the standard GRACE products are monthly means, with a lag of several weeks between the time of observation and the data product release. The hydrology community is accustomed to instantaneous, daily or better observations available in near-real time. Finally, at the time of this writing, the algorithms used to produce readily available global gridded hydrology maps were not sophisticated enough to address issues such as gravity signal leakage (blurring of time variable gravity features across the boundaries of adjacent regions). Extracting quantitatively reliable TWS time series from global GRACE gravity solutions has typically required the involvement of a trained geodesist. Recently, the GRACE science team has made it a priority to develop "off-the-shelf" research-quality hydrology products in order to accelerate the adoption of GRACE for hydrological research and applications including drought monitoring (Rodell et al., 2010).

VI. Disaggregating and Downscaling GRACE Data

Satellite gravimetry data are quite different from and highly complementary to most other types of hydrology data. Many of the challenges to using GRACE-derived TWS data described above can be addressed by combining them with other information. Using the simple disaggregation method suggested by Rodell and Famiglietti (2002), Yeh et al. (2006) isolated groundwater storage variations averaged over Illinois by subtracting soil moisture and snow water storage (based on in situ network observations) from GRACE-based TWS. Rodell et al. (2007) accomplished the same for groundwater variations in the Mississippi River basin and its major sub-basins using soil moisture and snow water storage estimated by numerical land surface models (LSM). Both studies assumed that surface water and biomass variations were insignificant in the central U.S. compared to groundwater, soil moisture, and TWS (Rodell and Famiglietti, 2001; Rodell et al., 2005).

A more sophisticated approach for separating GRACE-derived TWS into individual water storage components is to integrate these and other relevant data within a LSM via data assimilation. LSMs simulate the redistribution of water and energy incident on the land surface using physical equations of the processes involved. They incorporate soil, vegetation, and topographic parameters, and use meteorological fields such as precipitation and solar radiation as time-varying inputs (known as "forcing"). These forcing fields can be atmospheric analysis system outputs, observational data products, or a combination of the two. Advantages of LSMs include their spatial and temporal continuity, resolution, and low cost. However, their accuracy is limited by the quality of the input data, the model developers' understanding of the physics involved, and the simplifications necessary to represent complex Earth system processes in a

computationally efficient manner. Further, most LSMs have a lower boundary at the bottom of the root zone, about 2-3 m below the land surface. Only models able to simulate groundwater storage are compatible with, and thus able to assimilate GRACE based TWS observations.

The objective of data assimilation is to combine multiple estimates of a state variable (TWS, in this case) to produce a single, more accurate estimate. Data assimilation combines the advantages of observations (ground- or remote sensing-based) and numerical modeling, in that the model fills spatial and temporal gaps in the observations, provides quality control, and enables data from disparate observing systems to be merged, while the observations anchor the results in reality. A commonly used data assimilation approach is the Kalman filter (Kalman, 1960), which computes a weighted average of a predicted value and a measured value, with the weights being inversely proportional to the uncertainty in each estimate. The ensemble Kalman filter (e.g., Reichle et al., 2002) uses a finite number of model trajectories (the ensemble) to estimate uncertainty in the model physics, parameters, and forcing data, with a value for each model spatial element (grid cell, catchment, or other discretization of the spatial model domain).

Whereas filters assimilate observations as they become available and update only the most recent model states, smoothers assimilate time series of observations to update model states over a specified period (Dunne and Entekhabi, 2005; Evensen and van Leeuwen, 2000). Smoothers are therefore well suited to GRACE observations, which are non-instantaneous. Zaitchik et al. (2008) developed an ensemble Kalman smoother approach for assimilating GRACE data into the Catchment LSM (Koster et al., 2000), in which the smoothing periods are identical to the epochs of the GRACE products (i.e., calendar months). The Catchment model was chosen because it

simulates groundwater, which is uncommon among LSMs but essential for assimilation of TWS. The ensemble update is computed separately for each coarse scale GRACE observation. The basis for the distribution of information from the scale of these observations ($>150,000 \text{ km}^2$) to that of the model elements (roughly $2,500 \text{ km}^2$ for the Catchment LSM) and from TWS to its components (groundwater, soil moisture, and snow) is a matrix of cross-covariances between the TWS observations and model predicted component states at each location, which is computed *a priori* using all data in the period of record. This matrix has dimensions for TWS components and model elements, and it also varies in time.

Zaitchik et al. (2008) demonstrated that their data assimilation scheme successfully disaggregates and spatially and temporally downscales the GRACE-based TWS data into higher resolution fields of unconfined groundwater, surface and root zone soil moisture, and snow water equivalent. Figure 2 shows that the assimilated results have much higher spatial resolution than the GRACE observations, and Figure 3 illustrates the disaggregation of water storage components and improvement in temporal resolution from monthly to nearly continuous. Zaitchik et al. (2008) compared the open loop (Catchment model run with no data assimilation) and assimilated output with observation-based groundwater and runoff data, and, significantly for the drought monitoring application described in this chapter, concluded that assimilating GRACE data improved the accuracy of the results (Figure 3). For time series of groundwater storage averaged over the Mississippi River basin, the coefficient of correlation increased from 0.59 to 0.70 and the root mean square error diminished from 23.5 mm to 18.5 mm equivalent height of water. GRACE data assimilation also improved results in the four major sub-basins of the Mississippi (not shown). Modeled runoff generally improved as well, but at a statistically

insignificant level. The groundwater data used for evaluation were based on measurement records from 58 wells archived by the USGS (Rodell et al., 2007), while runoff data for the Mississippi River basin and three major sub-basins were made available by the U.S. Army Corps of Engineers and USGS. Data assimilation has the additional benefit of extrapolating the GRACE data record to near-real time, using precipitation and other observation based products that are available with minimal latency and taking advantage of the long "memory" (persistence or time scale of variability) of TWS.

VII. Drought Monitoring with GRACE

Standard drought quantification methods and products including the U.S. Drought Monitor (USDM; discussed further in a subsequent paragraph) rely heavily on *in situ* observations of precipitation, stream flow, and snowpack data. These largely constitute the point-based measures, gridded images generated via geostatistical interpolation, indices such as the Palmer Drought Severity Index, and soil moisture estimates from a simple water balance ("bucket") model that are used by the USDM authors to draw weekly maps, along with satellite based vegetation greenness, and any other reports (both objective and subjective) that the authors consider to be informative. Observations of groundwater and soil moisture are conspicuously lacking. While drought is defined as an extended period with deficient precipitation, droughts are also influenced by precursor conditions, seasonality, the intensity of rain that does fall, solar radiation, and other meteorological factors. LSMs are designed to account for all of these variables, which has motivated the development of new LSM-based drought products. These include the North American Land Data Assimilation System (NLDAS) Drought Monitor (Chapter ##) and Princeton University's Drought Monitoring and Hydrologic Forecasting with

the Variable Infiltration Capacity LSM (Luo and Wood, 2007). However, such products only consider the upper layers of the soil column (to about 2 m depth), and as with PDSI and USDM, they do not yet incorporate systematic observations of soil moisture, groundwater, or collective TWS.

Surface moisture conditions can fluctuate quickly with the weather, while the deeper components of TWS (e.g., groundwater) are well suited to drought quantification, particularly hydrologic droughts, because they integrate meteorological conditions over timescales of weeks to years. As mentioned before, GRACE is the only current satellite remote sensing mission able to monitor water below the first few centimeters of the land surface. Hence assimilating GRACE data into a groundwater-inclusive LSM is appealing as a new drought monitoring method, combining observations of deep water storage with the resolution and timeliness of a numerical model. The resulting maps of relative groundwater storage and shallow and deep soil moisture address major gaps in current drought monitoring capabilities. *In situ* measurement records of these variables are often short or discontinuous, have poor spatial coverage, and may not be centralized and easily accessible. The GRACE data assimilation approach also yields maps of evaporation, transpiration, and runoff, which may be consulted as secondary indicators of drought.

The application of the GRACE data assimilation approach for drought monitoring has recently been explored by a NASA-funded investigation. The objectives are to develop surface and root zone soil moisture and groundwater drought indicators based on GRACE data assimilation results, and to assess the value of those indicators as inputs to the USDM and North American

Drought Monitor (NADM) products. The USDM program was initiated in the late 1990s to centralize the drought monitoring activities conducted by federal, regional, and state entities in the U.S. (Svoboda et al., 2002). USDM drought maps are published on a weekly basis by a team of authors, and these are widely considered to be the premier drought products available for use by governments, farmers and other stakeholders, and the public, despite limited groundwater and soil moisture data as direct inputs. The NADM is based on the USDM concept and spans Canada, Mexico, and the United States.

Figure 4 summarizes the process of incorporating assimilated GRACE data into the Drought Monitors. Houborg and Rodell (2010) used groundwater well observations to corroborate the accuracy of the new drought indicator products and at the time of this writing we are evaluating the utility of these products as inputs to the short-term and long-term "objective blends" (amalgams of several drought indicators) that serve as baselines for the Drought Monitor maps. Their value will be determined through comparisons between the original and experimental objective blends and the final Drought Monitor products, and based on feedback from Drought Monitor authors and other end-users.

The new indicators are generated as follows (Houborg and Rodell, 2010). First, an open loop simulation of the Catchment LSM is executed for the period 1948 to near present. This provides the climatological background for identifying droughts and quantifying their severity based on probability of occurrence. Monthly GRACE TWS anomaly fields, which are defined to have a long-term zero mean at every location, are converted to absolute TWS fields by adding the time-mean total water storage field from the open loop LSM output. Thus the mean field of the

assimilated TWS output is assured to be nearly identical to that of the open loop, which is to say that assimilating the GRACE data does not introduce a bias. We use a model restart file (set of initial conditions) from the open loop to initialize the GRACE data assimilating simulation (including the ensemble) when the first GRACE TWS data field is available in 2002.

While bias in the assimilation is prevented by the method of converting TWS anomalies to model-appropriate water storage values, the GRACE data, and therefore the assimilation results, could still have a larger or smaller range of variability than the open loop LSM results at any given location. This is an important consideration because drought monitoring concerns the extremes. Therefore, a statistical adjustment must be applied to correct for differences in the range of variability between the assimilation-mode and open loop model output. This is accomplished by computing cumulative distribution functions (CDF) of wetness at each model pixel for the open loop and assimilation results during the overlapping period (2002 to near present) and mapping between the two CDFs. Finally, drought indicator fields for surface (top several centimeters) soil moisture, root zone soil moisture, and groundwater are computed based on probability of occurrence in the 1948-present record. For ease of comparison with the Drought Monitor objective blends, droughts can be characterized from D0 (abnormally dry) to D4 (exceptional), corresponding to decreasing cumulative probability percentiles of 20-30%, 10-20%, 5-10%, 2-5%, and 0-2%, and translated the results from the model grid onto coarser-resolution climate divisions. It should be noted that the original objective blends use a somewhat longer climatological background period, which begins in 1932.

Figure 5 shows examples of the new groundwater and soil moisture drought indicators in comparison with the original (non-GRACE) objective blends and USDM product for the epoch at the end of June 2005. The level of agreement and disagreement typifies that displayed by the various drought indicators and USDM product, though the patterns of disagreement are variable. In this example, all six maps generally show drought extending from Texas to Michigan and eastward to the mid-Atlantic coast, and another drought occurring in the northwest, with some differences in severity and extent (particularly in the case of the long-term objective blend). Note that the three GRACE based maps (left panels) are not identical. The soil moisture percentile maps indicate drought conditions across all of Texas, while groundwater levels are still normal to high outside of easternmost Texas. Having maps of multiple TWS components will help the USDM authors to distinguish agricultural (shallow) droughts from hydrological (deep/water resources) droughts. The USDM currently depicts both types of drought on the same map. In some locations such as Idaho and the Four Corners area of the southwest, all three GRACE-based maps conflict with the USDM product. The objective blends are equivocal in these regions, which suggests that the new drought indicators would have been a valuable source of additional information for the USDM authors when they were drawing the map. A lack of independent, reliable data precludes determining which map is closest to the truth, but records indicate that in June of 2005 both Idaho and the Four Corners area were near the end of multi-year droughts, the visible remnants of which may have colored reports from inhabitants of those regions.

VIII. Future Prospects

The GRACE data assimilation-based approach described above delivers spatially continuous fields of anomalies in groundwater storage - an ideal drought indicator - that were previously unavailable. If they prove to be skillful (early indications are positive) and there is demand, the approach could be expanded to the global scale. At present, most drought monitoring products are regional (few exist outside of North America) and many drought stricken areas of the world lack adequate hydrological observing networks, so the potential benefits of a global product are even greater.

The approach could be refined in at least two ways. First, certain model parameters could be tuned to allow the LSM to better represent drought conditions. For example, early in the previously described project it was discovered that the range of TWS variability in the Catchment LSM was not large enough to represent severe multi-annual droughts. In certain locations it would reach a limit of dryness. The solution was to increase the model's depth to bedrock parameter, which was determined to have minimal undesired impact on modeled fluxes. As evaluation of the results continues and as the approach is expanded beyond North America, it may be determined that other adjustments are necessary. Second, the GRACE data assimilation scheme could be implemented in the Community Land Model (CLM) and other groundwater-inclusive LSMs as they are developed. That would facilitate assessment of uncertainty by enabling one to establish the degree to which the choice of LSM affects the simulation and detection of dry extremes. Kato et al. (2007) used *in situ* observations to demonstrate that the standard deviation of multiple LSM outputs provides a conservative estimate of uncertainty in those outputs.

GRACE has already persisted well beyond its designed lifetime of five years, and it is the only satellite mission able to measure temporal variations in the gravity field with the precision necessary to detect changes in terrestrial water storage. Depending on battery and instrument health and fuel consumption for orbital adjustments, the mission might continue into the middle of this decade. NASA, the European Space Agency, and various other organizations have begun discussions of a next-generation satellite gravimetry mission, which would improve upon GRACE's horizontal resolution by perhaps a factor of four by replacing the microwave ranging system with a laser interferometer and flying at a lower altitude in atmospheric-drag-free spacecraft (NRC, 2007). While the improved resolution will be valuable, it will not overcome the need for further downscaling via data assimilation. In the meantime, NASA has begun initial development of a follow-on to GRACE with a nearly identical mission design, which would provide continuity in the data record while affording some small improvement in resolution due to basic technological advancements of the past ten years. That mission could launch as soon as 2016 and enable gravimetry-based drought monitoring into the next decade.

References

- Chao, B. F., and W. P. O'Connor, Global surface-water-induced seasonal variations in the Earth's rotation and gravitational field, *Geophys. J. R. Astronom. Soc.*, 94, 263-270, 1988.
- Crowley, J. W., J. X. Mitrovica, R. C. Bailey, M. E. Tamisiea, and J. L. Davis, 2006: Land water storage within the Congo Basin inferred from GRACE satellite gravity data. *Geophys. Res. Lett.*, 33.
- Dickey, J. O., C. R. Bentley, R. Bilham, J. A. Carton, R. J. Eanes, T. A. Herring, W. M. Kaula, G. S. E. Lagerloef, S. Rojstaczer, W. H. F. Smith, H. M. van den Dool, J. M. Wahr, and M.

- T. Zuber, Satellite gravity and the geosphere, *National Research Council Report*, National Academy Press, Washington D. C., 112 pp., 1997.
- Dunne, S., and D. Entekhabi (2005), An ensemble-based reanalysis approach to land data assimilation, *Water Resour. Res.*, 41, W02013, doi:10.1029/2004WR003449.
- Evensen, G. Sequential data assimilation with a nonlinear quasi-geostrophic model using Monte Carlo methods to forecast error statistics, *J. Geophys. Res.* 99(C5):10143-10162, 1994.
- Gutierrez, R., and C. R. Wilson, Seasonal air and water mass redistribution effects on Lageos and Starlette, *Geophys. Res. Lett.*, 14(9), 929-932, 1987.
- Han, Shin-Chan; Kim, Hyungjun; Yeo, In-Young; Yeh, Pat; Oki, Taikan; Seo, Ki-Weon; Alsdorf, Doug; Luthcke, Scott B. 2009: "Dynamics of surface water storage in the Amazon inferred from measurements of inter-satellite distance change." *Geophysical Research Letters* 36 - L09403 (DOI <http://dx.doi.org/10.1029/2009GL037910>)
- Houborg, R., and M. Rodell, Integrating Enhanced GRACE Terrestrial Water Storage Data into the U.S. and North American Drought Monitors, in *Proceedings of the ASPRS 2010 Annual Conference*, American Society for Photogrammetry and Remote Sensing, 2010.
- Jeffreys, H., 1952. *The Earth: Its origin, history, and physical constitution*. Cambridge University Press, London, 392 pp.
- Kalman, R.E. (1960). A new approach to linear filtering and prediction problems. *Journal of Basic Engineering*, 82 (1): 35–45.

- Kato, H., M. Rodell, F. Beyrich, H. Cleugh, E. van Gorsel, H. Liu, and T. P. Meyers, Sensitivity of land surface simulations to model physics, land characteristics, and forcings, at four CEOP sites, *J. Meteor. Soc. Japan*, 87A, 187-204, 2007.
- Koster, R. D., M. J. Suarez, A. Ducharme, M. Stieglitz, and P. Kumar, 2000: A catchment-based approach to modeling land surface processes in a general circulation model 1. Model structure. *Journal of Geophysical Research-Atmospheres*, 105, 24809-24822.
- Luo , L. and E. F. Wood (2007), Monitoring and predicting the 2007 U.S. drought, *Geophys. Res. Lett.*, 34, L22702, doi:10.1029/2007GL031673
- Luthcke, S. B.; Zwally, H. J.; Abdalati, W.; Rowlands, D. D.; Ray, R. D.; Nerem, R. S.; Lemoine, F. G.; McCarthy, J. J.; Chinn, D. S. 2006: Recent Greenland ice mass loss by drainage system from satellite gravity observations." *Science* 314 1286.
- Luthcke, S.B., A.A. Arendt, D.D. Rowlands, J.J. Mccarthy, and C.F. Larsen, Recent glacier mass changes in the Gulf of Alaska region from GRACE mascon solutions, *J. Glaciology*, 54, 767-777, 2008.
- National Research Council, *Earth Science and Applications from Space: National Imperatives for the Next Decade and Beyond*, National Academies Press, Washington DC, 2007.
- Ramillien, G.; Lombard, A.; Cazenave, A.; Ivins, E. R.; Llubes, M.; Remy, F.; Biancale, R. 2006: Interannual variations of the mass balance of the Antarctica and Greenland ice sheets from GRACE. *Global and Planetary Change* 53 198 - 208.
- Reichle, R., D. McLaughlin, and D. Entekhabi, Hydrologic data assimilation with the Ensemble Kalman filter, *Mon. Weather Rev.* 130(1):103-114, 2002.

- Rodell, M., and J. S. Famiglietti, An analysis of terrestrial water storage variations in Illinois with implications for the Gravity Recovery and Climate Experiment (GRACE), *Wat. Resour. Res.*, 37, 1327-1340, 2001.
- Rodell, M., and J. S. Famiglietti, The potential for satellite-based monitoring of groundwater storage changes using GRACE: The High Plains aquifer, central U.S., *J. Hydrol.*, 263, 245-256, 2002.
- Rodell, M., J. S. Famiglietti, J. Chen, S. Seneviratne, P. Viterbo, S. Holl, and C. R. Wilson, Basin scale estimates of evapotranspiration using GRACE and other observations, *Geophys. Res. Lett.*, 31, L20504, doi:10.1029/2004GL020873, 2004.
- Rodell, M., B. F. Chao, A. Y. Au, J. Kimball, and K. McDonald, Global biomass variation and its geodynamic effects, 1982-1998, *Earth Interactions*, 9 (2), 1-19, 2005.
- Rodell, M., J. Chen, H. Kato, J. Famiglietti, J. Nigro, and C. Wilson, Estimating ground water storage changes in the Mississippi River basin (USA) using GRACE, *Hydrogeology Journal*, doi:10.1007/s10040-006-0103-7, 2007.
- Rodell, Matthew; Velicogna, Isabella; Famiglietti, James S. 2009: Satellite-based estimates of groundwater depletion in India. *Nature* 460 999 - U80 (DOI <http://dx.doi.org/10.1038/nature08238>).
- Rodell, M., J.S. Famiglietti, and B.R. Scanlon, "Realizing the Potential of GRACE for Hydrology", *EOS Trans. AGU*, 91 (10), p. 96, 2010.
- Rowlands DD, Luthcke SB, Klosko SM, Lemoine FGR, Chinn DS, McCarthy JJ, Cox CM, Anderson OB (2005) Resolving mass flux at high spatial and temporal resolution using GRACE intersatellite measurements. *Geophysical Research Letters* 32: L04310, doi:10.1029/2004GL021908.

- Sheffield, Justin; Ferguson, Craig R.; Troy, Tara J.; Wood, Eric F.; McCabe, Matthew F. 2009: "Closing the terrestrial water budget from satellite remote sensing." *Geophysical Research Letters* 36 - L07403 (DOI <http://dx.doi.org/10.1029/2009GL037338>).
- Svoboda, M., D. LeComte, M. Hayes, R. Heim, K. Gleason, J. Angel, B. Rippey, R. Tinker, M. Palecki, D. Stooksbury, D. Miskus, and S. Stephens, 2002. The Drought Monitor. *Bull. Amer. Meteor. Soc.*, 83(8):1181-1190.
- Swenson, S., and J. Wahr, Estimating Large-scale Precipitation Minus Evapotranspiration from GRACE Satellite Gravity Measurements, *J. Hydrometeorology*, Vol. 7, No. 2, pp. 252-270, doi: 10.1175/JHM478.1, 2006.
- Swenson, Sean; Yeh, Pat J. F.; Wahr, John; Famiglietti, James 2006: A comparison of terrestrial water storage variations from GRACE with in situ measurements from Illinois. *Geophysical Research Letters* 33 16401 -
- Swenson, Sean 2010: "Assessing High-Latitude Winter Precipitation from Global Precipitation Analyses Using GRACE." *Journal of Hydrometeorology* 11 405 - 420 (DOI <http://dx.doi.org/10.1175/2009JHM1194.1>).
- Syed, T. H., J. S. Famiglietti, J. Chen, M. Rodell, S. I. Seneviratne, P. Viterbo, and C. R. Wilson, 2005: Total basin discharge for the Amazon and Mississippi River basins from GRACE and a land-atmosphere water balance. *Geophys. Res. Lett.*, 32.
- Tamisiea, M. E., E. W. Leuliette, J. L. Davis, and J. X. Mitrovica, 2005: Constraining hydrological and cryospheric mass flux in southeastern Alaska using space-based gravity measurements. *Geophys. Res. Lett.*, 32.
- Tapley, B. D., S. Bettadpur, J. C. Ries, P. F. Thompson, and M. M. Watkins, GRACE measurements of mass variability in the Earth system, *Science*, 305, 503-505, 2004.

- Tiwari, V. M.; Wahr, J.; Swenson, S. 2009: Dwindling groundwater resources in northern India, from satellite gravity observations. *Geophysical Research Letters* 36 - L18401 (DOI <http://dx.doi.org/10.1029/2009GL039401>).
- Velicogna, I., and J. Wahr (2005), Greenland mass balance from GRACE, *Geophys. Res. Lett.*, 32, L18505, doi:10.1029/2005GL023955.
- Velicogna, I. and J. Wahr, 2006: Measurements of time-variable gravity show mass loss in Antarctica. *Science*, 311, 1754-1756.
- Wahr, J., M. Molenaar, and F. Bryan, Time-variability of the Earth's gravity field: hydrological and oceanic effects and their possible detection using GRACE, *J. Geophys. Res.*, 103(B12), 30,205-30,230, 1998.
- Wahr, J., S. Swenson, V. Zlotnicki, I. Velicogna, Time-VARIABLE Gravity from GRACE: First Results, *Geophys. Res. Lett.*, 31, doi:10.1029/2004GL019779, 2004.
- Wahr, J., S. Swenson, and I. Velicogna, The Accuracy of GRACE Mass Estimates, *Geophys. Res. Lett.*, 33, L06401, doi:10.1029/2005GL025305, 2006.
- Yeh, P. J. F., S. C. Swenson, J. S. Famiglietti, and M. Rodell, 2006: Remote sensing of groundwater storage changes in Illinois using the Gravity Recovery and Climate Experiment (GRACE). *Water Resources Research*, 42, W12203, doi:10.1029/2006WR005374.
- Yoder, C. F., J. G. Williams, J. O. Dickey, B. E. Schutz, R. J. Eanes, and B. D. Tapley, Secular variation of Earth's gravitational harmonic J_2 coefficient from Lageos and nontidal acceleration of Earth rotation, *Nature*, 303, 757-762, 1983.
- Zaitchik, B.F., M. Rodell, and R.H. Reichle, Assimilation of GRACE terrestrial water storage data into a land surface model: results for the Mississippi River Basin, *J. Hydrometeor.*, 9 (3), 535-548, doi:10.1175/2007JHM951.1, 2008.

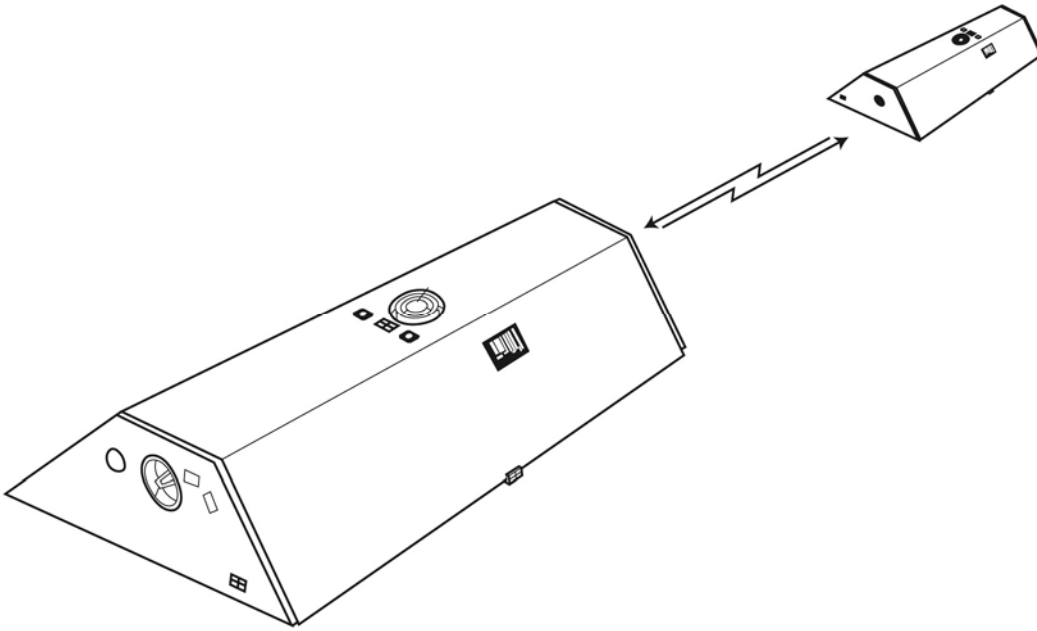
Figures

Figure 1. Artist's rendering of the GRACE satellite pair, which orbits the Earth at about 500 km altitude. The second satellite follows about 200 km behind the first, and the precise separation is continuously measured by a K-band microwave tracking system. (Credit: NASA).

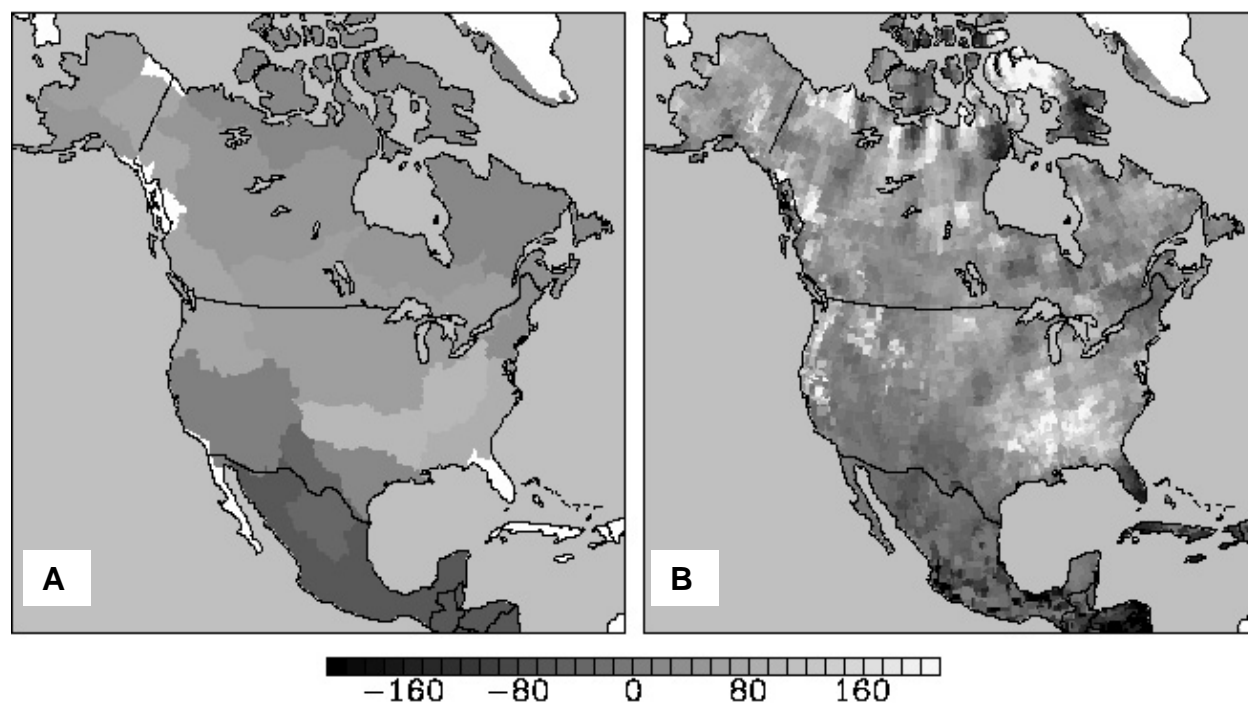


Figure 2. Comparison of maps of terrestrial water storage anomalies (mm) over North America for May 2009 (areas of pure white, including Florida in map A, indicate no data), (A) at the resolution (major river basins) at which they are derived from GRACE data, and (B) at the resolution (catchments intersected with an atmospheric forcing grid) of the data assimilation output. (Credit: Bailing Li, University of Maryland.)

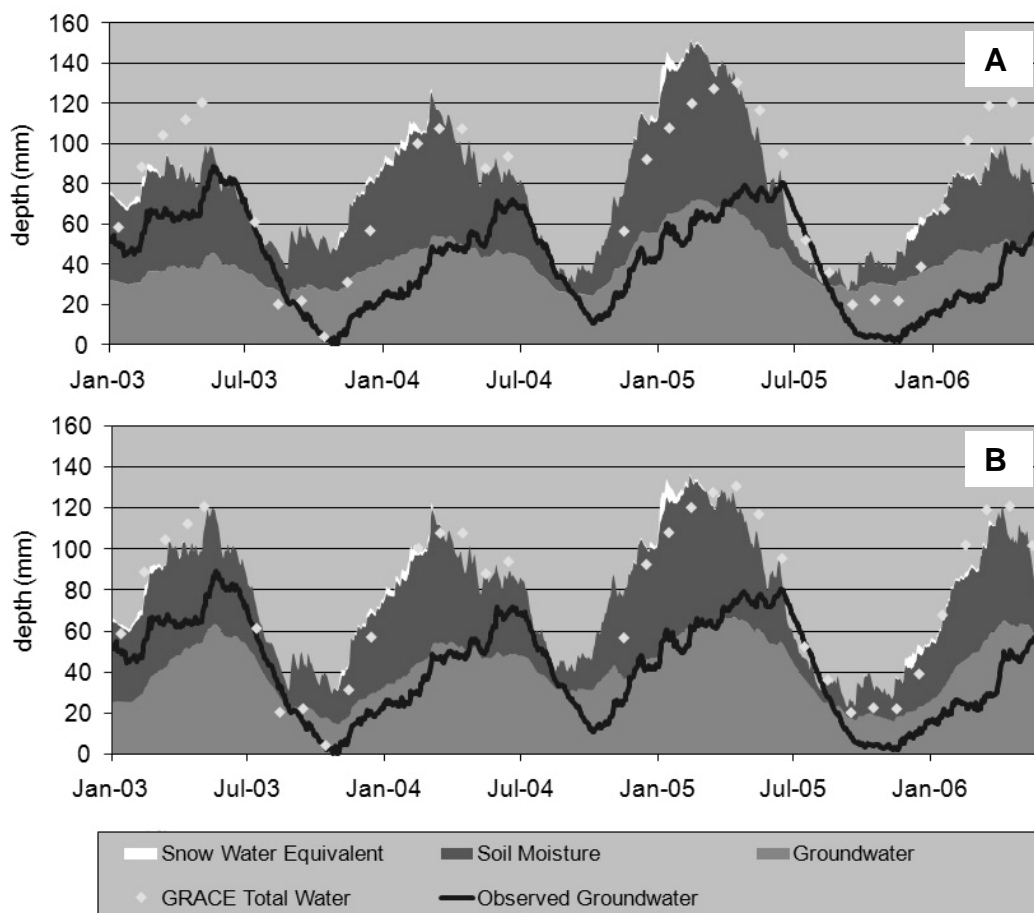


Figure 3. Groundwater, soil moisture, and snow water equivalent averaged over the Mississippi river basin from (A) open loop model output and (B) GRACE data assimilation. Also shown are daily, observation-based groundwater and monthly GRACE-derived TWS time series. GRACE-based and modeled TWS were adjusted to a common mean, as were observed and modeled groundwater. The coefficient of correlation between modeled and observed groundwater time series improved from 0.59 to 0.70 due to GRACE data assimilation. (From Zaitchik et al., 2008. Reprinted with permission.)

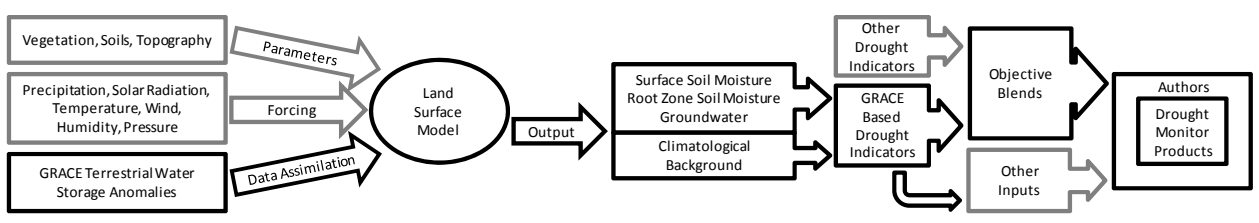


Figure 4. Flowchart illustrating the process for incorporating GRACE terrestrial water storage data into the Drought Monitor products. "Other Inputs" include drought indicators and subjective reports that are used at the discretion of the Drought Monitor authors.

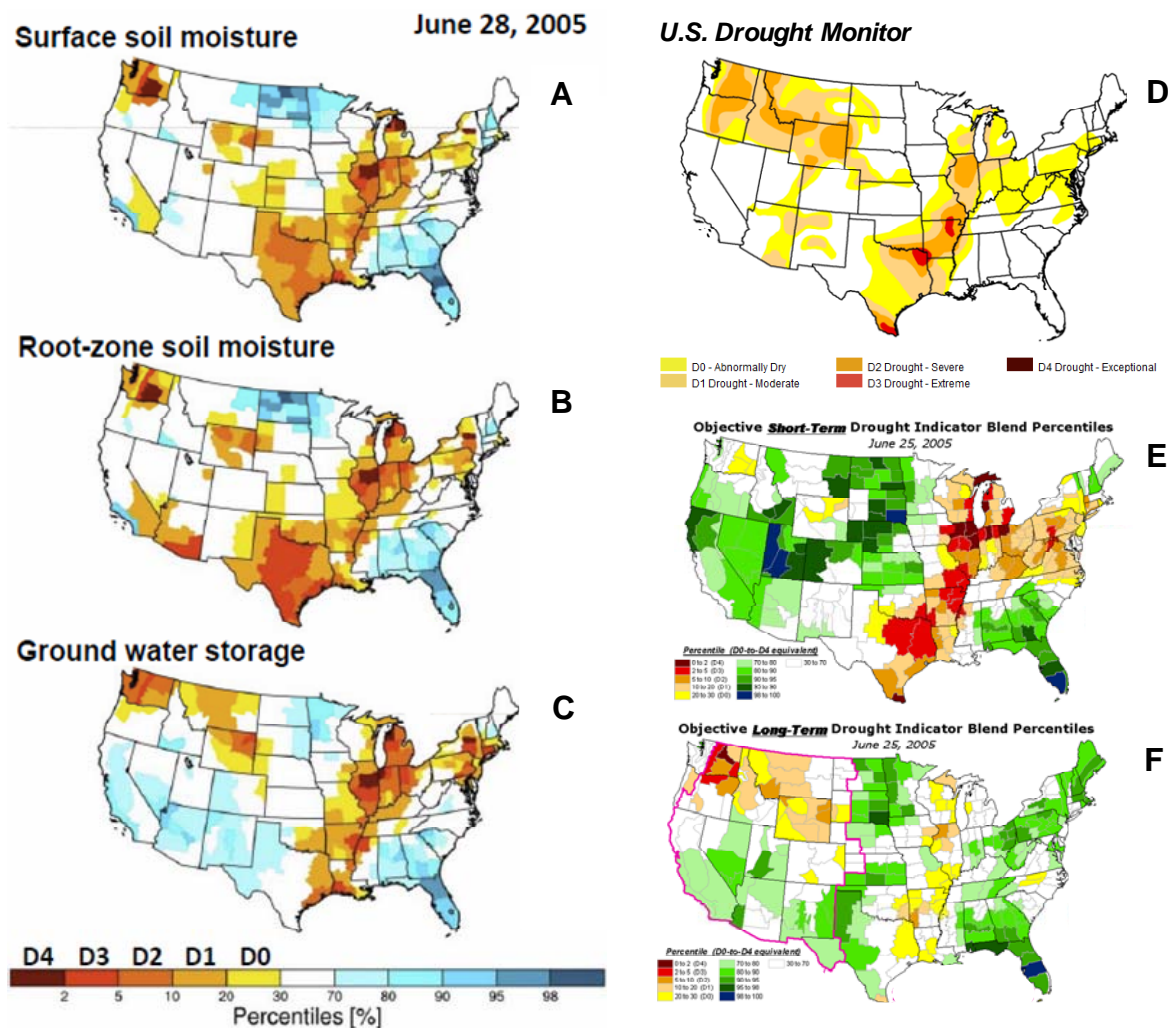


Figure 5. Surface soil moisture (top several centimeters) (A), root zone soil moisture (B), and groundwater storage (C) drought indicators, on U.S. climate divisions, based on GRACE data assimilation results for June 28, 2005, compared with the U.S. Drought Monitor product for June 28, 2005 and short term (E) and long term (F) objective blends, which constitute the baselines for the Drought Monitor products, for June 25, 2005. (Credit: Rasmus Houborg, University of Maryland).