

FY12 X-ray Concept Study Workshop

BACKGROUND, STUDY PROCESS, WORKSHOP OBJECTIVES

Rob Petre
Study Scientist

Approved for public release, distribution unlimited

Outline

- Background
- X- ray Study: Objectives, Process, Participants, Schedule
- Workshop Objectives

Approved for public release, distribution unlimited

Background (1 of 3)

- Constellation-X was NASA's flagship X-ray mission from 1996 until 2008
 - High resolution spectroscopy with large effective area
 - Four mirrors with calorimeter and gratings, plus HXT
 - Ranked 2nd among large missions in 2000 decadal survey
 - Substantial technology development – mirrors, calorimeters, gratings
- X-ray Evolving Universe Spectrometer mission (XEUS) was European counterpart, selected in 2006 as L-class candidate to ESA Cosmic Visions
 - Very large collecting area with wide field imaging plus high resolution spectroscopy, high time resolution and polarimetry
 - Selected as one of three L-class mission candidates
- In 2008, the missions were merged to form the International X-ray Observatory (IXO)
 - Submitted to both US Decadal Survey and Cosmic Visions

Approved for public release, distribution unlimited

Background (2 of 3)

- In 2010 IXO was ranked fourth among large missions in *New Worlds New Horizons*
 - Key IXO science is high resolution spectroscopy
 - IXO should cost no more than \$2B; 10 arcsec resolution acceptable
 - Strong recommendation to develop optics and other key technology to higher readiness level (~\$200M over decade)
- In March 2011, ESA decided to redefine all three L candidates, in reaction to US decadal survey recommendations
 - ESA component of mission to be less than ~€800M
 - US participation reduced to ≤\$150M level
 - Downselect decision postponed until February 2012
- ESA decision meant the termination of IXO (and LISA)
- ESA has subsequently developed Athena concept
 - Two mirrors, focusing onto WFI and microcalorimeter

Approved for public release, distribution unlimited

Background (3 of 3)

- IXO study activities in US were terminated in fall 2011
 - Prior to termination:
 - Produced mirror development plan
 - Developed AXSIO concept (IXO redesigned to meet decadal constraints)
- X-ray study activities and technology development moved under PCOS
 - SAT plus directed support for technology in 2012
- In October 2011, NASA HQ directed PCOS office to lead concept study to identify more cost effective ways to perform IXO and LISA science

Approved for public release, distribution unlimited

The road to the next flagship X-ray observatory

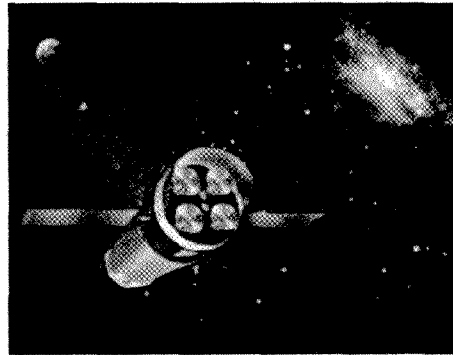

Constellation-X
(1996-2008)

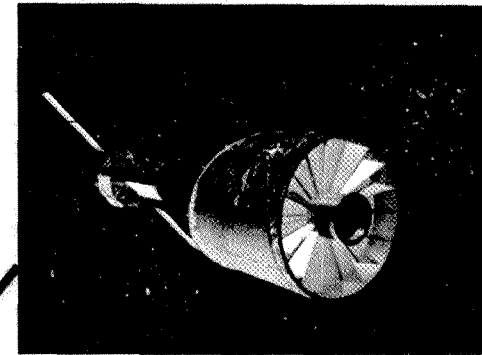
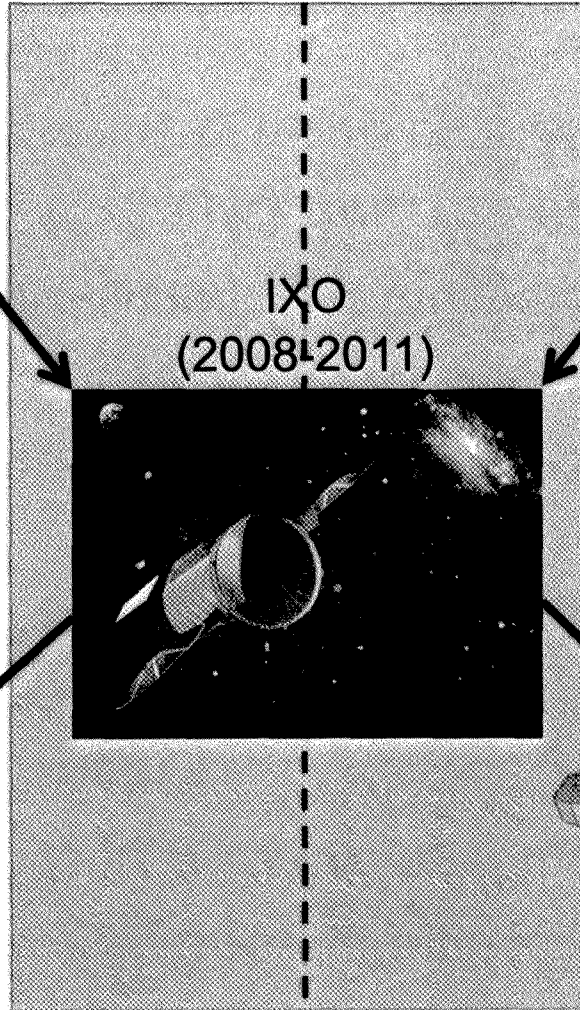

XEUS
(2006-2008)

???

NASA

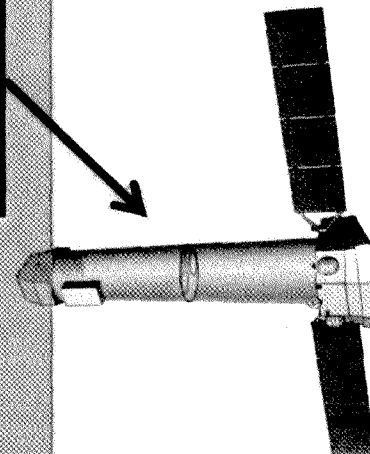

Athena
(2011-??)

ESA

Approved for public release, distribution unlimited

X-ray Concept Study

- **Objectives**

- Determine the range of science objectives of IXO that can be achieved at a variety of lower cost points
- Explore mission architectures and technical solutions that are fundamentally different from the heritage designs
- Fully engage the community and ensure that all voices are heard, all perspectives considered
- Create data for a report to the CAA that describes options for science return at multiple cost points for X-ray astronomy

- **Deliver final report to NASA HQ that**

- Describes and analyzes trade space of science return vs. mission cost
- Summarizes the mission concepts developed during the study and how they relate to the trade space and other mission concepts that were not developed in a design lab
- Summarizes the RFI responses and the workshop and describes how they were folded into the whole study

Approved for public release, distribution unlimited

Study Components

- ✓ **Request for Information (RFI):** solicit ideas for missions and enabling technology. **29 responses received.**
- ✓ **Community Science Team (CST):** 10 members of the community selected by NASA HQ to serve as the study science team.
- ✓ **Workshop:** provide the community a forum to comment on concepts and technology and identify concepts for further study.
 - **Notional Missions:** Define up to three mission concepts at different cost points.
 - **Design Labs:** Study team develops concepts through mission design lab runs. Focus is on identifying the technical and cost drivers of each concept.
 - **Final Report:** Summarizes study activities and results for HQ and CAA. **Due to NASA HQ on June 7, 2012**

Approved for public release, distribution unlimited

Study Team Composition

- **Study Manager** – Gerry Daelemans (GSFC)
- **Study Scientist** – Rob Petre (GSFC)
- **Community Science Team** – 10 members selected by NASA HQ
- **Science Support Team** – Andy Ptak (GSFC), Jay Bookbinder, Randall Smith, Mike Garcia (SAO)
- **Engineering Support Team** – Tony Nicoletti, Gabe Karpati (GSFC), Mark Freeman, Paul Reid (SAO), discipline engineers
- **Support & oversight from:**
 - PCOS Program Office (GSFC)
 - Ann Hornschemeier (Chief Scientist)
 - Jackie Townsend
 - NASA HQ
 - Rita Sambruna (PCOS Program Scientist), Richard Griffiths, Wilt Sanders
 - Jaya Bajpayee (PCOS Program Executive)

Approved for public release, distribution unlimited

Community Science Team Members

- Joel Bregman (Michigan) - chair
- Mark Bautz (MIT)
- David Burrows (Penn State)
- Webster Cash (Colorado)
- Christine Jones-Forman (CfA)
- Steve Murray (Johns Hopkins)
- Paul Plucinsky (CfA)
- Brian Ramsey (NASA / MSFC)
- Ron Remillard (MIT)
- Colleen Wilson-Hodge (NASA / MSFC)

Approved for public release, distribution unlimited

Study Schedule

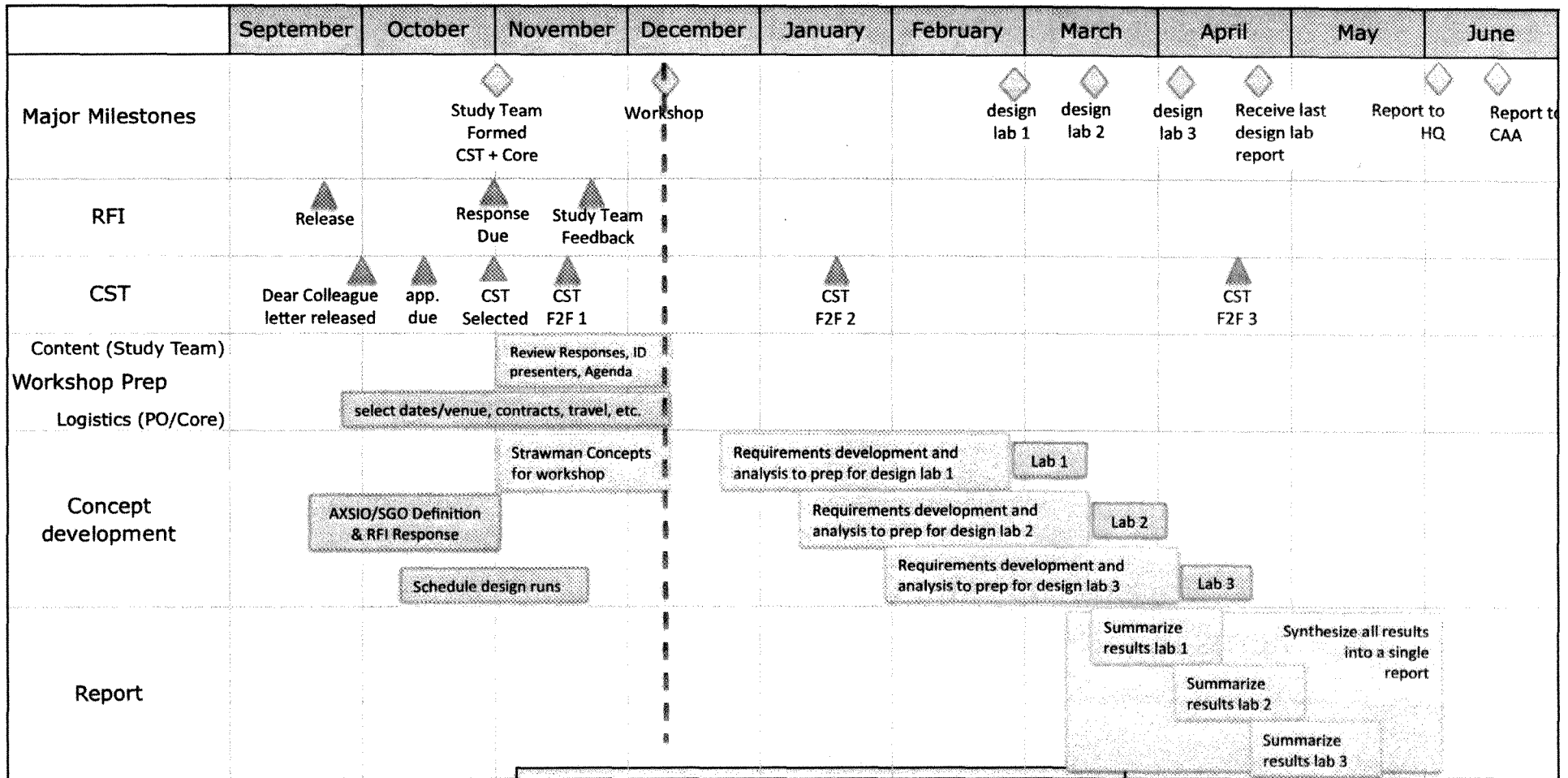

Approved for public release, distribution unlimited

Note: schedule for a single study; PO will be running two simultaneously

Workshop Objectives

- Provide the community an opportunity to comment on the study and shape the missions that will be developed in design labs.
 - In the aggregate, the notional missions should probe various points of the science return vs. mission cost trade space.
 - Nominal “cost bins”:
 - $\leq \$0.5\text{B}$ (small)
 - $\sim \$1.0\text{B}$ (medium)
 - $\sim \$2\text{B}$ (large)
 - Options considered can come from RFI responses, modifications thereof or independent research.
- Provide a forum for discussion and exchanging information between the study team and the community.

Approved for public release, distribution unlimited

Boundary Conditions

- The basis for discussion and selection of concepts for further study is the degree of compliance with IXO science objectives, as endorsed by NWNH.
- We are **NOT** revisiting decadal survey decisions regarding science questions or mission priorities.
- We are studying *representative* missions for the various cost classes. The goal is to assess the fraction of IXO science that can be performed vs. mission cost. There are no winning or losing concepts. It is unlikely that any submitted concept will be taken to the design lab “as is.”
- No recommendation for a specific mission or a preferred cost class will be given in the final report. This is the CAA’s responsibility.
- External constraints (e.g., Athena) will need to be taken into consideration.

Approved for public release, distribution unlimited

Enabling Technology

- RFI called for responses regarding enabling technology
- Technology responses will be used to:
 - Inform discussion about notional missions
 - Provide input to NASA about key areas to be addressed through PCOS funding
 - Identify in final report key technology areas where support needed for short and long term needs

Approved for public release, distribution unlimited

FY12 X-ray Concept Study Workshop

BACKUP SLIDES

Rob Petre
Study Scientist

Approved for public release, distribution unlimited

Roles, Responsibilities, Authority: Study Team

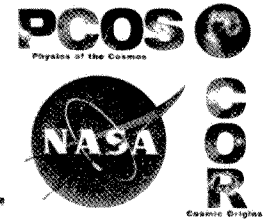

- **Study Team:** Study Manager, Study Scientist, Core Team, Community Science Team (CST), some additional engineers as budget allows (e.g., staff from design labs), PO/ACTO support staff
- Responsibility and Authority for implementing the study resides with the Study Manager in consultation with the Study Scientist
- **Study manager** receives this study plan, budget, schedule and has authority to make changes that do not compromise the objectives of the study (comparable to Level 1 requirements) or affect top level budget or due date of final report.
 - Delivers detailed, specific study plan
 - Primary POC and interface with ACTO, PO and HQ (as needed)
 - Manages the Study Team (CST + Core Team)
 - Manages each design lab run
 - Manages the workshop
 - Manages the analysis, writing, and delivery of the final report
- **Study scientist** is responsible for all science aspects of the study and is the primary point of contact for the CST and the broader community
 - Manages the science team (Core + CST), defining and ensuring delivery of all science products
 - CST: Ex officio member; works in consultation with the CST Chair to define objectives and deliverables, supports the work to ensure delivery
 - Workshop: Host and primary responsibility for content
 - Responsible for science content of design lab runs
 - Manages all science analyses and input to the final report
 - Primary POC for all communication with the broader science community

Approved for public release, distribution unlimited

Community Science Team (CST)

- **CST Description:** The Study Team is comprised of the Core Team and the CST. The CST participates in the full study process, analyzing RFI responses, organizing and participating in the workshop, determining concepts to study, participating in design lab runs, and writing final reports.
- **Purpose:** Engage new stakeholders and new approaches, encourage the incorporation of new ideas into the study
- **CST Roles:**
 - Evaluate the RFI responses for the degree to which they allow fulfillment of the IXO science objectives, and technical readiness
 - Assist in the organization of and participate in a concept study workshop
 - Based on input from the RFI and workshop, identify a small number (≤ 3) of concepts for further study
 - Participate in the mission studies, including potential involvement in the mission design laboratory activities
 - Participate in the writing of a report summarizing the study findings and present the report to NASA and the CAA

Approved for public release, distribution unlimited

Design Lab Runs

- **Description:** The design lab runs provide the bulk of study data. Study Team develops NM concepts through mission design lab runs. Lab focus: identifying the technical and cost drivers for each concept.
- **Lab Input and Output:**
 - **Input:** ~50 page chart package that defines mission objectives, requirements, constraints, operations, and payload elements to the greatest detail possible.
 - **Output:** Each lab run produces list of drivers relevant to the trade space, a mission concept (may not close on solution) of sufficient resolution to understand the drivers for the trade space, cost products (Price H with mission wraps) and ~200 pages of presentation material and design package. Note: every design center has unique ops, unique products, and uses its own cost estimation tools.
- **Tasks**

	Study Team	January - April 2012
--	------------	----------------------

 - Prepare input package (each run) defining mission objectives, requirements, constraints, risks, operations and payload elements to the greatest detail possible
 - Pre-brief one week before design lab run
 - Spend one week in design lab performing all trades and making all decisions needed to close on a functional design if possible. If not possible, make assumptions that allow team to discover main drivers for that case with respect to trade space. Final products lab usually received ~4 weeks after run.
 - Review lab run and findings and identify any lessons that apply to the next lab run in the queue
 - Draft summary report on each design lab run, distribution unlimited

Final Report

- The final product of the study is a report that:
 - Describes and analyzes the trade space of science return vs. mission cost
 - Summarizes the mission concepts developed during the study and how they relate to the trade space and other mission concepts that were not developed in a design lab.
 - Identifies key technologies, summarizes current state, and degree of development needed
 - Summarizes the RFI responses and the workshop and describes how they were folded into the whole study
- Final report due date for HQ review: **June 7, 2012**

Approved for public release, distribution unlimited

