

face and verify all sensors via Web-based interfaces. Confidence is improved in decisions due to the use of fusion algorithms. Performance is improved in adverse environmental conditions. Costs for setup and teardown are reduced. Re-

calibration when replacing sensors is not required as the data acquisition system can autonomously recalibrate itself. The costs for installation, maintenance, and upgrades for measurement and control systems are also reduced.

This work was done by Ray Wang of Mobitrum Corporation for Stennis Space Center. For more information, contact Ray Wang, Mobitrum Corporation, (301) 585-4040. Refer to SSC-00361.

Extended-Range Passive RFID and Sensor Tags

SAW devices and retroreflective antenna arrays are combined.

Lyndon B. Johnson Space Center, Houston, Texas

Extended-range passive radio-frequency identification (RFID) tags and related sensor tags are undergoing development. A tag of this type incorporates a retroreflective antenna array, so that it reflects significantly more signal power back toward an interrogating radio transceiver than does a comparable passive RFID tag of prior design, which does not incorporate a retroreflective antenna array. Therefore, for a given amount of power radiated by the transmitter in the interrogating transceiver, a tag of this type can be interrogated at a distance greater than that of the comparable passive RFID or sensor tag of prior design.

The retroreflective antenna array is, more specifically, a Van Atta array, named after its inventor and first published in a patent issued in 1959. In its simplest form, a Van Atta array comprises two antenna elements connected by a transmission line so that the signal received by each antenna element is reradiated by the other antenna element (see Figure 1). The phase relationships among the received and reradiated signals are such as to produce constructive interference of the reradiated signals; that is, to concentrate the reradiated signal power in a direction back toward the source. Hence, an RFID tag equipped with a Van Atta antenna array automatically tracks the interrogating transceiver. The effective gain of a Van Atta array is the same as that of a traditional phased antenna array having the same number of antenna elements. Additional pairs of antenna elements connected by equal-length transmission lines can be incorporated into a Van Atta array to increase its directionality.

Like some RFID tags heretofore commercially available, an RFID or sensor tag of the present developmental type includes one-port surface-acoustic-wave (SAW) devices. In simplified terms, the mode of operation of a basic one-port

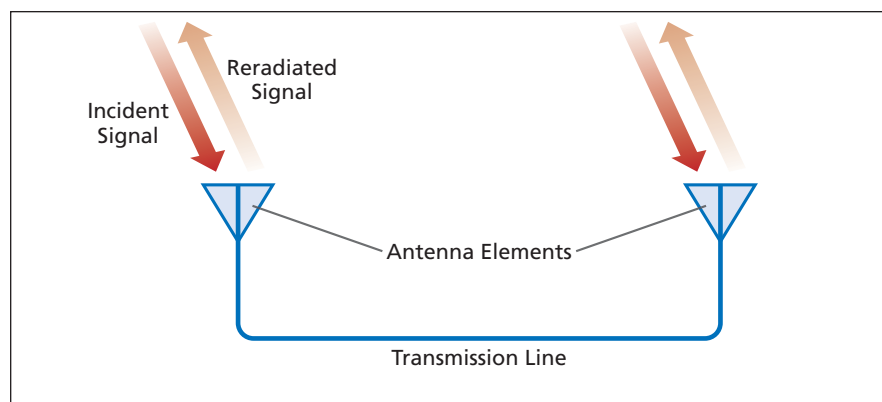

Figure 1. A Van Atta Array in its simplest form, comprising two antenna elements connected via a transmission line, exhibits partial retroreflection of an incident radio signal. If more pairs of antennas connected by equal-length transmission lines are added, the array becomes more nearly completely retroreflective.

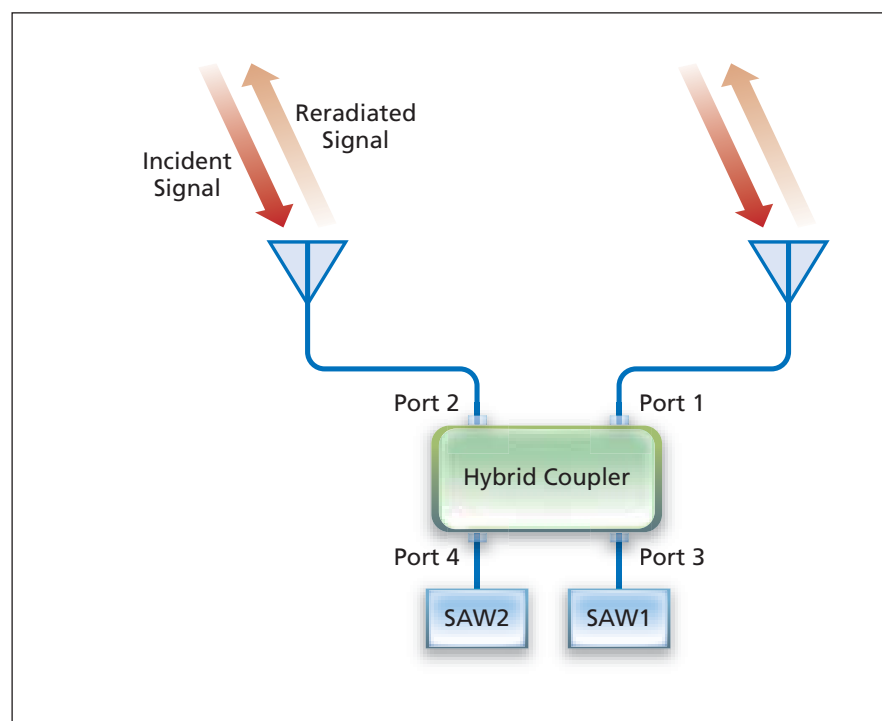

Figure 2. An Extended-Range Passive RFID or Sensor Tag in its simplest form includes two antenna elements and two SAW devices incorporated into a Van Atta array by use of a hybrid 90° coupler. A more highly directional (and, hence, longer-range) tag would incorporate additional subunits, each incorporating a similar pair of SAW devices and a similar pair of antenna elements connected via a hybrid 90° coupler.

SAW device as used heretofore in an RFID device is the following: An interrogating radio signal is converted, at an input end, from an electrical signal to an acoustic wave that propagates along a surface and encounters multiple reflectors suitably positioned along the surface. Upon returning to the input end, the reflected acoustic wave is re-converted to an electrical signal, which, in turn, is reradiated from an antenna. The distances between the reflectors in the SAW device and the corresponding times between reflections encode the identifying or sensory information onto the reradiated signal.

The fundamental problem in the present development is how to combine a Van Atta antenna array (which is inherently a multiple-port device) and one or more one-port SAW device(s) into a single, compact, passive unit that can function as a retroreflective RFID tag. The solution is to use one or more hybrid,

half-power 90° couplers. A basic unit of this type, shown in Figure 2, includes a half-power 90° hybrid coupler; two identical SAW devices (SAW1 and SAW2) connected to ports 3 and 4 of the coupler, respectively; and antenna elements connected to ports 1 and 2 of the coupler. Necessarily omitting details for the sake of brevity, it must suffice to report that the phase relationships among the coupler inputs and outputs are such as to couple the incident signal from the antenna elements to the SAW devices and couple the reflected signals from the SAW devices back to the antenna elements in the phase relationships required for a Van Atta array. Hence, the reradiated signal is automatically directed back toward the interrogating transceiver and contains identifying and/or sensory information encoded in time intervals between reflections.

An initial test of a prototype extended-range passive RFID tag of this

type containing two antennas yielded data indicative of a 37-percent increase in range over a comparable single-antenna tag. Assuming that the signal power needed to effect interrogation of a passive RFID device is proportional to the mathematical fourth power of distance, the corresponding increase in signal power needed to interrogate the single-antenna tag at the increased distance would be about 250 percent.

This work was done by Patrick W. Fink, Timothy F. Kennedy, and Gregory Y. Lin of Johnson Space Center; and Richard Barton of ERC. Further information is contained in a TSP (see page 1).

This invention is owned by NASA, and a patent application has been filed. Inquiries concerning nonexclusive or exclusive license for its commercial development should be addressed to the Patent Counsel, Johnson Space Center, (281) 483-1003. Refer to MSC-24346-1.

Hybrid Collaborative Learning for Classification and Clustering in Sensor Networks

NASA's Jet Propulsion Laboratory, Pasadena, California

Traditionally, nodes in a sensor network simply collect data and then pass it on to a centralized node that archives, distributes, and possibly analyzes the data. However, analysis at the individual nodes could enable faster detection of anomalies or other interesting events as well as faster responses, such as sending out alerts or increasing the data collection rate. There is an additional opportunity for increased performance if learners at individual nodes can communicate with their neighbors. In previous work, methods were developed by which classification algorithms deployed at sensor nodes can communicate information about event labels to each other, building on prior work with co-training, self-training, and active learning. The idea of “collaborative” learning was extended to function for clustering algorithms as well, similar to ideas from penta-training and consensus clustering. However, collaboration

between these learner types had not been explored.

A new protocol was developed by which classifiers and clusterers can share key information about their observations and conclusions as they learn. This is an active collaboration in which learners of either type can query their neighbors for information that they then use to re-train or re-learn the concept they are studying. The protocol also supports broadcasts from the classifiers and clusterers to the rest of the network to announce new discoveries.

Classifiers observe an event and assign it a label (type). Clusterers instead group observations into clusters without assigning them a label, and they collaborate in terms of pairwise constraints between two events [same-cluster (must-link) or different-cluster (cannot-link)]. Fundamentally, these two learner types speak different languages. To bridge this gap, the new communication protocol

provides four types of exchanges: hybrid queries for information, hybrid “broadcasts” of learned information, each specified for classifiers-to-clusterers, and clusterers-to-classifiers.

The new capability has the potential to greatly expand the *in situ* analysis abilities of sensor networks. Classifiers seeking to categorize incoming data into different types of events can operate in tandem with clusterers that are sensitive to the occurrence of new kinds of events not known to the classifiers. In contrast to current approaches that treat these operations as independent components, a hybrid collaborative learning system can enable them to learn from each other.

This work was done by Kiri L. Wagstaff of Caltech, Scott Sosnowski of Case Western Reserve University, and Terran Lane of the University of New Mexico for NASA's Jet Propulsion Laboratory. For more information, contact iaoffice@jpl.nasa.gov. NPO-47821