

Maturing Pump Technology for EVA Applications in a Collaborative Environment

Edward Hodgson, Steven Dionne

Hamilton Sundstrand Corporation, Windsor Locks, CT

Edward Gervais

Cascon Corporation, Yarmouth, Maine

Ian Anchondo

NASA, Lyndon B. Johnson Space Center, Houston, Texas

The transition from low earth orbit Extravehicular Activity (EVA) for construction and maintenance activities to planetary surface EVA on asteroids, moons, and, ultimately, Mars demands a new spacesuit system. NASA's development of that system has resulted in dramatically different pumping requirements from those in the current spacesuit system. Hamilton Sundstrand, Cascon, and NASA are collaborating to develop and mature a pump that will reliably meet those new requirements in space environments and within the design constraints imposed by spacesuit system integration. That collaboration, which began in the NASA purchase of a pump prototype for test evaluation, is now entering a new phase of development. A second generation pump reflecting the lessons learned in NASA's testing of the original prototype will be developed under Hamilton Sundstrand internal research funding and ultimately tested in an integrated Advanced Portable Life Support System (APLSS) in NASA laboratories at the Johnson Space Center. This partnership is providing benefit to both industry and NASA by supplying a custom component for EVA integrated testing at no cost to the government while providing test data for industry that would otherwise be difficult or impossible to duplicate in industry laboratories.

This paper discusses the evolving collaborative process, component requirements and design development based on early NASA test experience, component stand alone test results, and near term plans for integrated testing at JSCs.

I. Introduction

As NASA prepares for long duration human space exploration missions beyond low earth orbit, the development of a new spacesuit system has emerged as one of the significant technical challenges that must be overcome. A new system is required to enable astronauts to move freely and work effectively on planetary surfaces, to survive the rigors of long missions with many

Extra-Vehicular Activity (EVA) sorties, and to reduce EVA demands for consumable supplies that must be launched from Earth. Its development requires new technology and new designs in most EVA subsystems and components, and challenges not only the technical ingenuity of the engineering team, but also their creativity in accomplishing the task with limited available funding. This paper presents recent and continuing work to develop a new EVA water circulation pump as a collaborative NASA / industry effort to respond creatively to both the technical and fiscal challenge.

II. Background – Pump Requirements

The need for a new water circulation pump is driven by changes in both the mission requirements and the PLSS design. The transition from relatively short missions close to home requiring from 5 to 25 EVA's before ground servicing to long EVA intensive exploration missions that must be completed without resupply or ground support demands a more robust pump design and one that can be conveniently serviced during the mission. The loss of EVA capability experienced due to EMU pump failures on the ISS^{1 2 3} would have more serious consequences for an exploration mission to Mars, the moon, or an asteroid. To minimize the impact of a pump failure and improve in-space repair logistics, NASA is pursuing a PLSS design with a stand-alone water pump as used in the Apollo PLSS in place of the integrated fan / pump / water separator assembly used in the current EMU PLSS. In addition, the PLSS design has evolved to simplify the design for oxygen pressure regulation and reduce PLSS volume by placing the cooling water reservoir in the suit's pressurized volume and using the suit pressure rather than a separate regulated supply to feed water to the coolant loop and control pressure at the pump inlet.⁴ The planned integration of the new pump in an exploration PLSS is illustrated schematically in Figure 1.

The principal pump design requirements for this application are summarized in Table 1. Most notably, the requirement for the pump to operate at low inlet pressure after the make-up water reservoir has been reduced in pressure from vehicle atmospheric conditions (approximately 55 KPa (8 PSIA)) to EVA operating pressure (approximately 29 KPa (4 PSIA)) demands a design that can operate reliably with large quantities of free gas at the pump inlet and resists cavitation when operating at low inlet pressure, even with elevated water temperature. For operational flexibility, it is also important that the pump be self-priming, that is, capable of starting dry and filled with gas and drawing in water from the system water reservoir to establish water flow through the PLSS water loop and liquid cooling garment (LCG).

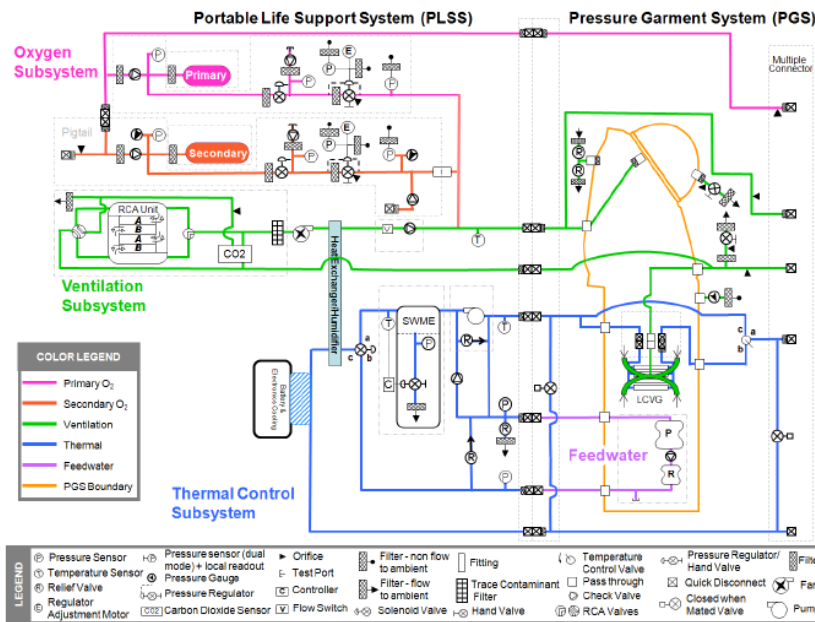

Figure 1. Water circulation pump integration in an exploration EVA PLSS. ⁵

Table 1. Top level requirements for a new exploration PLSS pump ⁶

No.	Description
Requirements	
1	Surface temperatures – 1.7 C to 38 C (35 F to 100 F)
2	Water flow rate and pressure rise – 91 Kg/hr at 35 KPa (200 lb/hr at 5 PSID), 82 Kg/hr at 69 KPa (180 lb/hr at 10 PSID)
3	Inlet Water Pressure – 23 – 69 KPa (In vacuum operating environment)
4	Useful Life – 2000 Hours minimum (~ twice planned EVA use)
5	Water quality – Potable water (recycled) per CxP 70024
6	External operating environment – laboratory ambient testing, consider vacuum
7	Standby and Start-up Capability – Inlet water between 1.7 and 38 C (35 to 100 F)
8	Drive motor – permanent magnet design
9	Power consumption – 15 W maximum at 5 PSID
10	Supply Voltage – 28 VDC nominal
11	Speed Control – to regulate flow between 20% and 120% of design points
Goals	
1	Servicing and Maintenance – replaceable in lunar and micro-gravity in space
2	Packaging geometry and volume - .00025 cu.m. (15 cu.in.) maximum, 5.7 cm x 7.0 cm x 5.7 cm (2.25 in. x 2.75 in. x 2.25 in.)
3	External operating environment goal – Deep space vacuum, Mars atmosphere
Design Considerations	
1	Consider replacement in space during lunar transit
2	Pass gas bubbles from cooling water source without major performance degradation
3	Consider water contamination issues
4	Consider packaging alternatives in design
5	Consider alternative materials to minimize pump mass

III. Initial Prototype Design and Manufacture

During 2008 and 2009, Hamilton Sundstrand worked under contract to NASA to develop and deliver a prototype pump to meet the needs of a future exploration PLSS. Pump technology options were evaluated in a trade study resulting in the selection of a gerotor based design as the best choice for this application since it combined positive displacement operation required for high free gas tolerance, efficiency, robustness, and low risk of cavitation. Based on that technology choice, Hamilton Sundstrand collaborated with Cascon to develop a detailed design, manufacture a prototype pump (Figure 2), and demonstrate its performance characteristics in a comprehensive test program that addressed all of the application requirements except operating life.



Figure 2. The original PLSS pump prototype used a coated aluminum housing to minimize weight.

The prototype was designed and manufactured under an aggressive schedule (< 6 months) in a program planned to address major performance risks on a cost effective basis. Consequently, it used a separately packaged commercial controller for drive electronics and made maximum use of design elements that could be adapted from commercial pump designs while achieving the desired performance characteristics. Design targets also included a very small packaging envelope and minimized component weight. The resulting design combined proven internal gerotor pumping components in wear and corrosion resistant materials, carbon bearings, and a light weight nickel plated aluminum housing.

IV. Prototype Stand-alone Test Results and Lessons Learned

Before delivery to NASA, the prototype pump was subjected to a battery of performance tests that included verification of pumping performance and efficiency over a range of operating

speeds and flow resistance conditions (Figure 3), confirmation of pumping efficiency and power consumption, demonstration of self-priming capability, tolerance for large amounts of free gas at the pump inlet, and cavitation resistance (Figure 4). Performance was verified both at ambient pressure and under the reduced pressure conditions expected in EVA use with NASA's exploration PLSS architecture including a suit pressure water reservoir.

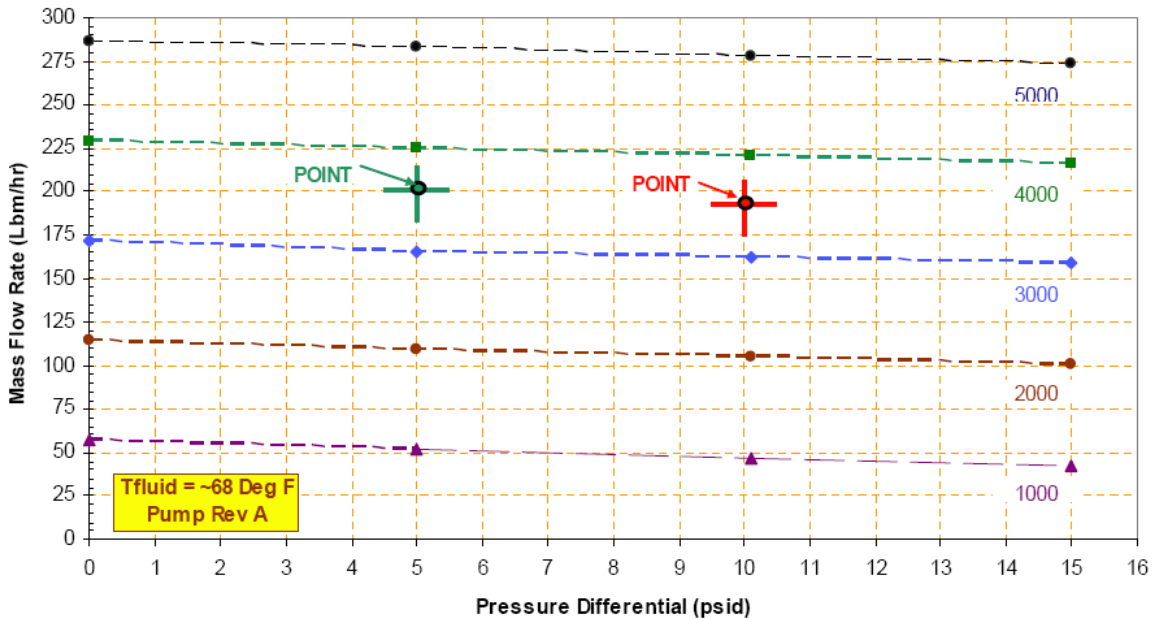

Figure 3. The prototype pump met flow performance requirements in testing over a wide range of conditions.

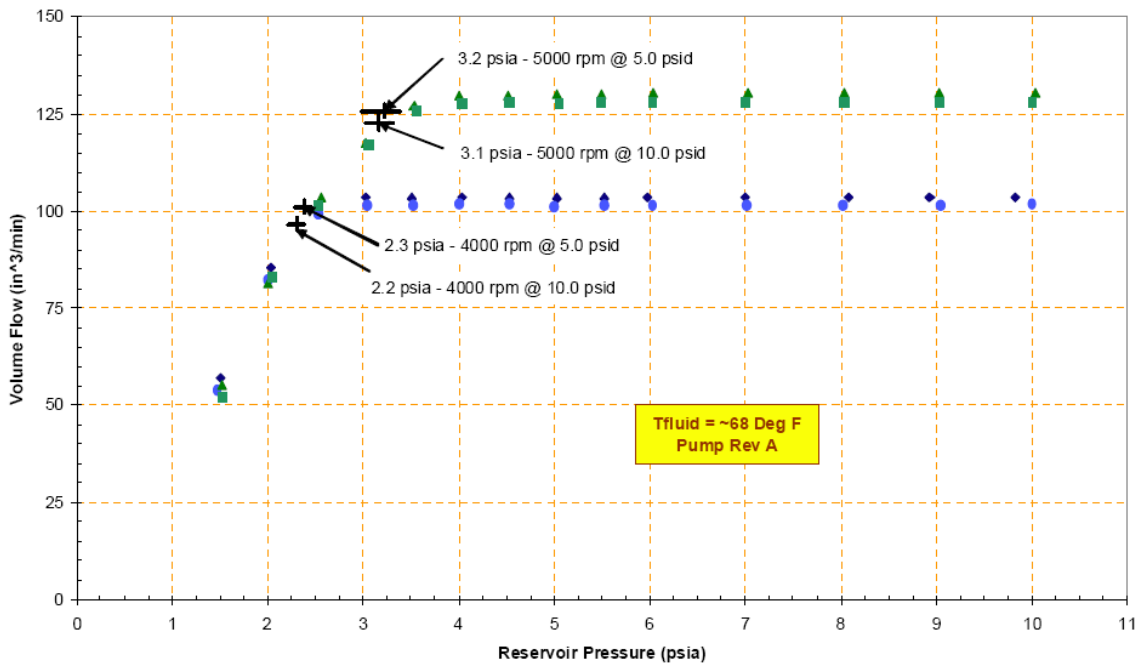

Figure 4. The prototype pump demonstrated resistance to cavitation under expected operating conditions in the exploration PLSS.

The prototype met all of its design performance requirements in these pre-delivery stand alone tests. Verification of pump life characteristics was planned at NASA in conjunction with pump use in integrated PLSS testing. Pump testing at NASA was delayed by several months after delivery as rigs were prepared. When testing was initiated, the pump failed to rotate. Examination of the pump ports and subsequent tear down inspection showed that the nickel plating on the inside surface of the aluminum housing and cover had been breached allowing corrosion of the aluminum and accumulation of resulting corrosion products (Figure 5) which jammed the pump. Although it was recognized that the use of coated aluminum was not sufficiently robust for an ultimate flight design, it was believed that the observed failure was attributable to a prolonged wet stand between pre-delivery testing and the subsequent NASA attempt. A second identical prototype was manufactured to support the planned NASA testing with the expectation that avoiding a long non-operating wet stand would allow completion of the planned test protocol. The new prototype showed essentially identical performance to the original in both industry and NASA labs (Figure 6) and was placed into endurance testing.



Figure 6. Corrosion products from the prototype aluminum housing are visible through the inlet port.

NASA CRAVE DO 37
GEROTOR PUMP PERFORMANCE
CASCO VS JSC

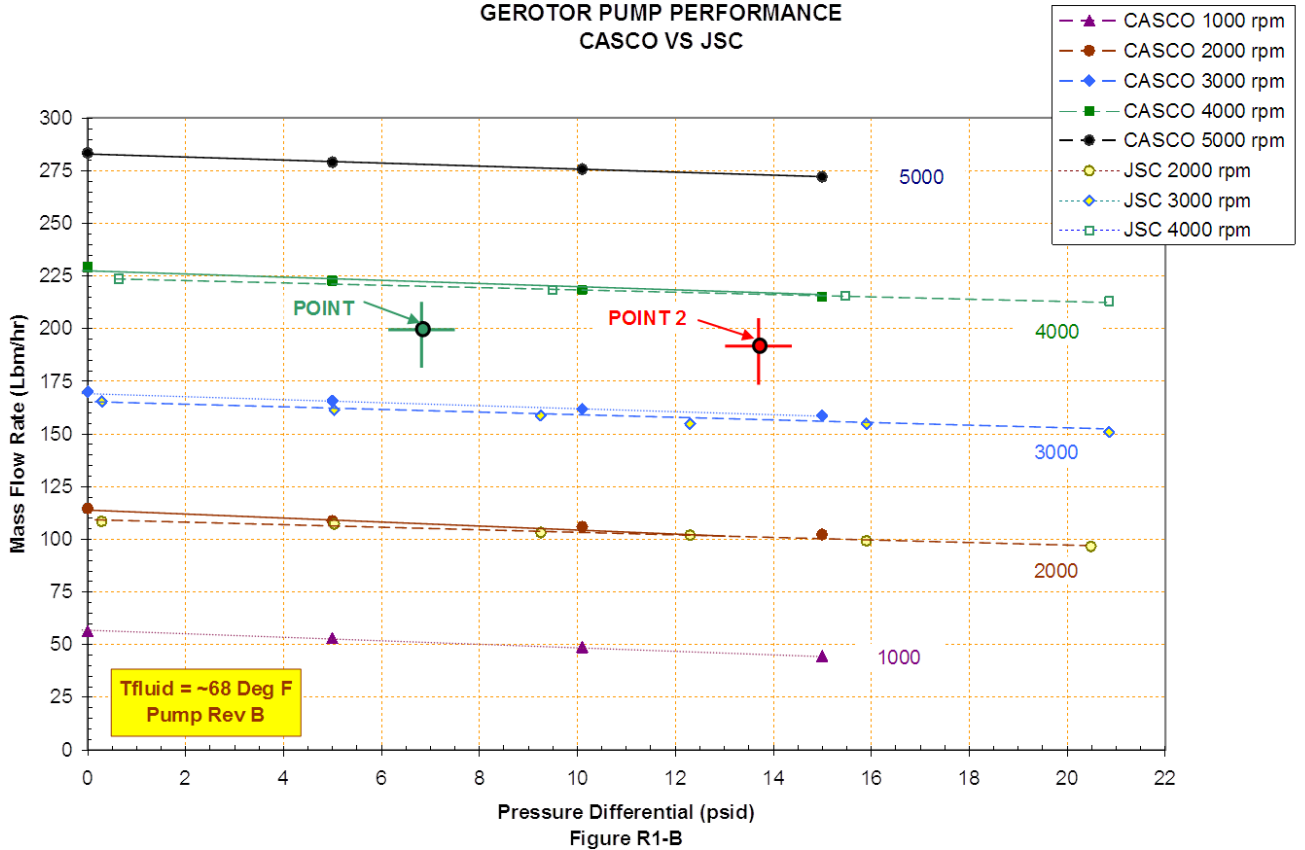

Figure 6. The second pump prototype matched the original prototype’s performance.

After two weeks of operation in the endurance test rig, the second prototype also failed and the cause was again traced to breach of the nickel plating and corrosion of the underlying aluminum. In this case, the breach occurred primarily on the cover, a relatively simple part. A new cover was manufactured and the pump cleaned and reassembled to provide an interim component that could support NASA test needs on an expedited basis. To date, the reassembled pump has not been used in testing, but continuing development of NASA’s PLSS integration concept has confirmed the need for a more robust component that provides the performance demonstrated in the original prototype design.

V. Advanced Prototype Objectives, Design, and Manufacture

Based on NASA’s requirement and the demonstrated superior performance capability of the previous prototypes, Hamilton Sundstrand and Cascon have collaborated to adapt the original design and implement it using more corrosion resistant materials to provide a new robust prototype pump that will provide long term service in water circulation applications. This industry funded effort was motivated by other commercial and space applications for the resulting pump and underlying technology as well as by the opportunity to provide future flight

hardware for the exploration PLSS based on the prototype's demonstrated capabilities and will benefit from collaboration with NASA integrated PLSS test efforts. The prototype is intended for use by NASA under a loan agreement to provide cooling water circulation in a prototype PLSS assembly that will be subjected to extensive performance testing. This NASA / industry collaboration provides NASA a necessary component for their system development test at no cost while it provides test data to industry that is vital for component design maturation and could not be obtained in any other way. The extended test experience in an integrated system with other life support subsystems and components over the full range of expected system operating conditions will verify pump performance and durability characteristics under truly representative application conditions including both known and unanticipated interactions with other system elements and water chemistry reflecting long term PLSS use through multiple mission cycles.

The new prototype pump uses the same gerotor pumping elements successfully applied to meet NASA's PLSS pump needs in the original prototype, but incorporates a stainless steel housing and end cover to ensure corrosion resistance in long term water service. Alternative bearing materials are also being investigated to provide improved control of critical clearance dimensions in manufacturing the pump. The pumping elements themselves were already manufactured in highly corrosion and wear resistant materials and require no change. In addition to material changes, the pump has been modified from the original prototype design to take advantage of continuing development in commercial pumps using the same pump technology and to improve the integration of the "canned motor" fluid barrier that isolates the drive motor windings from the pumped cooling water without requiring dynamic fluid seals in the assembly.

The new prototype includes a compact brushless dc drive circuit built into the pump assembly. This controller, developed for commercial pumping applications, requires a small increase in the pump package length, but eliminates the need for a separate drive electronics package. This provides a significant reduction in total PLSS packaging volume and allows pump speed control over the desired range for the original prototype from a central system control unit by varying the voltage applied to a speed control signal input in the pump assembly interface connector. A pump speed output signal is also provided supporting system monitoring needs.

In the new pump prototype, the canned motor fluid barrier is being manufactured as an integral part of the pump housing instead of as a separate mechanically installed sleeve. This eliminates the need for some assembly steps and for o-ring seals at the sleeve interfaces eliminating life limited components and potential leakage paths to provide a more robust unit. Implementing this design has also provided an opportunity for manufacturing development that can benefit future commercial and NASA products as it has required the refinement of techniques for producing deep thin walled cavities with extremely tight tolerances. The design for the new prototype is illustrated in Figure 7. Over-all the pump assembly with drive electronics is 13 cm (5.1 inches) long including the electronics housing and inlet port. It is 4.5 cm (1.8 inches) wide and 4.1 cm (1.6 inches) high with an additional local height increase of 1.7 cm (.66 inches) for the electrical connector at one end of the package.

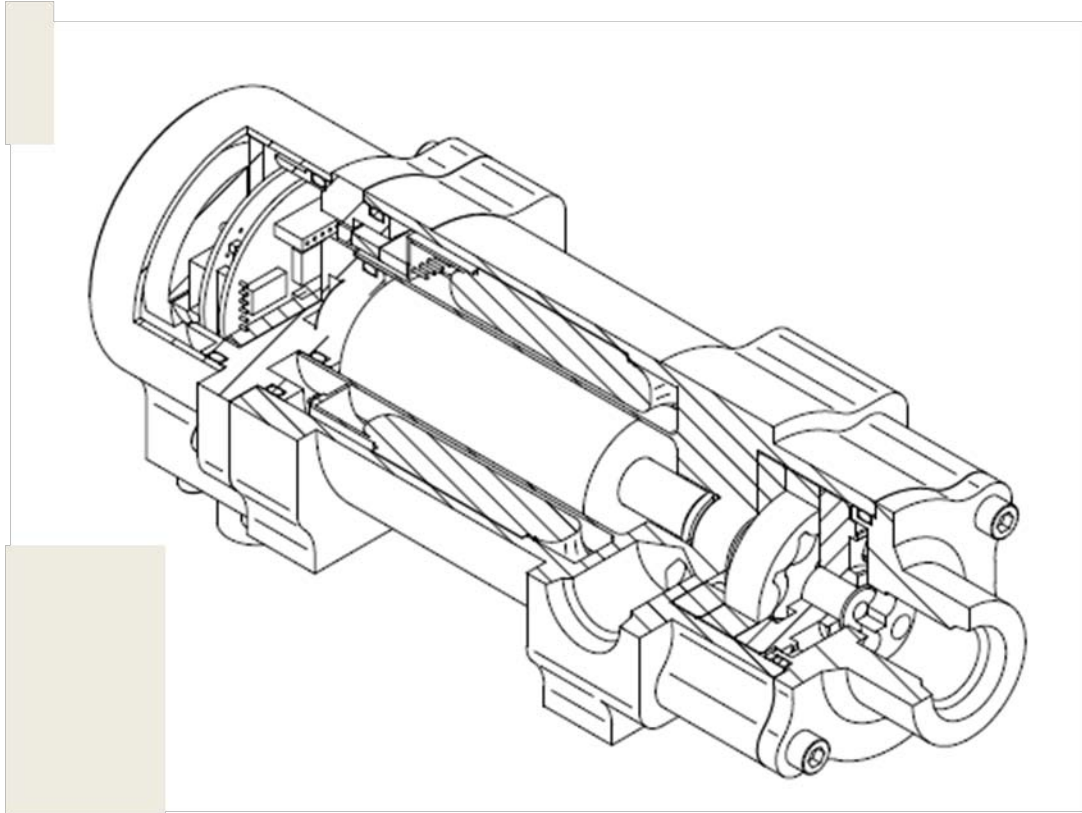

Figure 7. The new prototype pump incorporates corrosion resistant materials and integrated pump drive electronics.

VI. NASA PLSS Integration Testing Plans, Pump Application

PLSS 2.0 will be the integrated testing platform for the new prototype pump. The goal of the integrated test is to develop a test bed with flight like attributes. The pump will be integrated into the thermal loop with other NASA components such as the Suit Water Membrane Evaporator (SWME), Thermal Control Valve(TCV) and Feedwater Supply Assembly (FSA). Figure 8 shows a schematic representation of the Thermal Loop for the current design of the Advanced Portable Life Support System (APLSS).

The over-arching test objective for the second phase of the development work on the APLSS is to validate the full system integration as a packaged assembly across a simulated range of internal and external environments and vehicle interfaces. The APLSS will have two different test configurations along with 5 different orientations tested. First, the PLSS will be integrated to a Space Suit Assembly Simulator (SSAS), a urethane replica of a Mark III space suit, as shown in Figure 9.

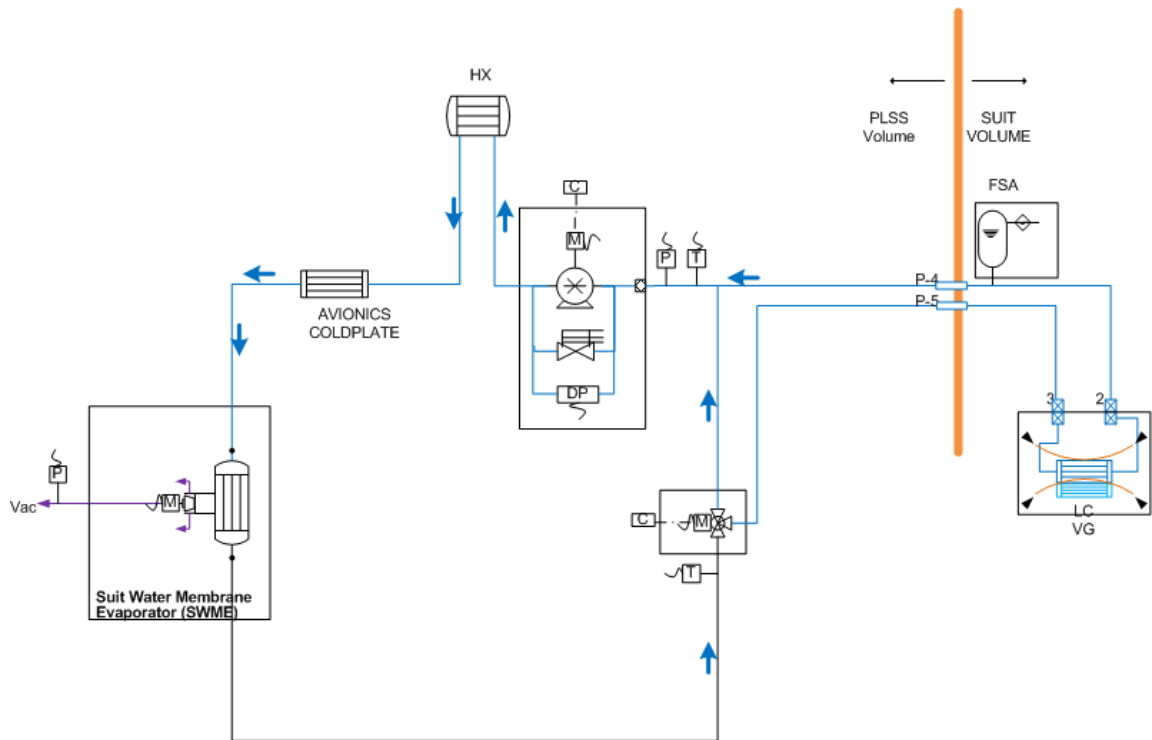

Figure 8. Current Thermal Loop in APLSS



Figure 9. Space Suit Assembly Simulator

The main goal in integration to the SSAS is to provide high-fidelity suit volume and pressure drop interactions for the entire PLSS system. The second configuration will be as a packaged APLSS inside a vacuum chamber to test 4 different orientations. External environments simulated will include cold, neutral and hot thermal environments, all ranging from -180 F to 180 F. Operating loads simulated will include metabolic rates ranging from 400 BTU/hr to 3000

BTU/hr with CO₂ and water injection to the system to replicate human metabolic effects at each energy output. The goal for the APLSS is to demonstrate autonomous functionality in the simulated EVA environment with the different external environments and crew work rate profiles as seen in a typical 8 hour EVA.

As part of the thermal loop in the APLSS, the prototype pump will be subjected to all the external environments and system operating conditions described above. As part of the primary objectives, the pump will be operated at a speed generating 200 pound per hour of water with differential pressures resulting from the other cooling loop components. The pump will be used to demonstrate several operational scenarios which include operation of the water loop with the integration of the Feedwater Supply Assembly(FSA), a flexible water accumulator pressurized by the suit volume to provide supply pressure to the water loop, In addition, the pump will test the operational concept of a vacuum water recharge in an umbilical configuration. The pump will also play a key role in proving the operational concept of split flow through the LCG using a Thermal Control Valve (TCV). The pump drive electronics will also be part of the control integration of all the components in the PLSS. The pump will also be an integral part of the operational sequence evaluation to perform suit initialization post-launch with a dry thermal loop which includes priming the system, recharging the FSA and degassing the loop.

The APLSS will also be tested under simulated component failures to determine response characterization of entire system under these conditions. The Cascon pump will be part of some these objectives which will include commanding the Suit Water Membrane Evaporator (SWME) off and seeing thermal loop response with the pump active. The pump will also be commanded to a low RPM setting to simulate degraded flow and determine system response and cooling capabilities. On the other hand, the pump will also be set to a high RPM to simulate a loss of pump control and determine the cooling efficiency and mitigations to continue operation of the thermal loop under these conditions.

As part of the secondary and tertiary objectives there will be an integration of component controllers to test an automated initialization state which will include the pump performing its task to initiate flow through the thermal loop and subsequently enable cooling to the avionics and vent loop.

The cooperation between industry and NASA in bringing an advanced pump prototype to this integrated test effort is making a significant contribution to its success. The availability of the demonstrated performance capabilities of the original development prototype in a small flight like package with the inclusion of motor drive electronics is an important factor in NASA's ability to address the full range of anticipated PLSS operating conditions in a realistic and flight like PLSS packaging volume enabling the advancement of the integrated system concept and other key components it includes.

VII. Significance / conclusions

The development of a prototype coolant pump for NASA's advanced PLSS provides an example of the potential power of NASA / industry collaboration to benefit technology development for

human space exploration and commercial uses on Earth and a pathfinder for future collaborative efforts. With a genesis in successful commercial pumping products, the pump has advanced through NASA investment in adapting the design to specific PLSS needs and testing in NASA laboratories that exposed opportunities for design improvement. Subsequent industry investment in implementing the identified enhancements is providing an advanced prototype that is helping to enable NASA advancement of integrated PLSS technology. In the process, NASA is generating test data and applications experience that will benefit industry in further developing the pump to better serve both NASA and commercial applications. Both NASA and industry costs to achieve important technology development objectives have been reduced.

Collaboration during the development of the pump prototype and the evolution of APLSS design has been an important asset to both industry and NASA in providing advance knowledge of key interfaces and performance needs and attributes to permit efficient integration of developmental items whose characteristics are in many cases not well characterized and subject to change over time.

VIII. Future Work

The integration of the prototype pump into NASA's development APLSS and initiation of test operations is anticipated in the near future. The authors anticipate that, as in any development activity, unanticipated questions and issues will arise. The foundation of cooperation and collaboration that has been established in reaching this point will enable an effective response to those surprises and continued progress toward the test data and results required to carry the pump and APLSS to the next level of maturity.

IX. References

¹ Lewis, J. F., Cole, H., Cronin, G., Gazda, D. B., Steele, J. W., "Extravehicular Mobility Unit (EMU) / International Space Station (ISS) Coolant Loop Failure and Recovery", ICES Paper, 2006-01-2040

² Peterson, Laurie, Derek Neumeyer, "Design and Certification of the Extravehicular Activity Mobility Unit (EMU) Water Processing Jumper", ICES Paper 2006-01-2096.

³ Steele, John W. Rector, Tony, Gazda, Daniel B., and Lewis, John, "Performance of the Extravehicular Mobility Unit (EMU) Airlock Coolant Loop Remediation (A/L CLR) Hardware" 2008-01-2060

⁴ Conger, Bruce, Chullen, Cinda, Barnes, Bruce, Leavitt, Greg, "Proposed Schematic for an Advanced Development Lunar Portable Life Support System", AIAA 2010-6038

⁵ Conger, Bruce, Chullen, Cinda, Barnes, Bruce, Leavitt, Greg, "Proposed Schematic for an Advanced Development Lunar Portable Life Support System", AIAA 2010-6038.

⁶ Hartman, David, et al, "Development of a Prototype Water Pump for Future Space Suit Applications", SAE-2009-01-2450