

Experimental Investigation of Transient Sublimator Performance

Rubik B. Sheth¹ and Ryan A. Stephan.²

National Aeronautics and Space Administration, Houston, TX, 77058

and

Thomas O. Leimkuehler³

Paragon Space Development Corporation, Houston, TX, 77058

Sublimators have been used as heat rejection devices for a variety of space applications including the Apollo Lunar Module and the Extravehicular Mobility Unit (EMU). Sublimators typically operate with steady-state feedwater utilization at or near 100%. However, sublimators are currently being considered for operations in a cyclical topping mode, which represents a new mode of operation for sublimators. Sublimators can be used as a supplemental heat rejection device during mission phases where the environmental temperature or heat rejection requirement changes rapidly. This scenario may occur during low lunar orbit, low earth orbit, or other planetary orbits. In these mission phases, the need for supplemental heat rejection will vary between zero and some fraction of the overall heat load. In particular, supplemental heat rejection is required for the portion of the orbit where the radiative sink temperature exceeds the system setpoint temperature. This paper will describe the effects of these transient starts and stops on the feedwater utilization during various feedwater timing scenarios. Experimental data from various scenarios is analyzed to investigate feedwater consumption efficiency under the cyclical conditions. Start up utilization tests were conducted to better understand the transient performance. This paper also provides recommendations for future sublimator design and transient operation.

Nomenclature

u	= Utilization
m_i	= Ideal sublimation rate
m_a	= Actual sublimation rate
Q_{orbit}	= Heat Load for an Orbit
Δh	= Heat of Vaporization
$OAFU$	= Orbit Averaged Feedwater Utilization
dt	= time step
C_p	= Specific Heat
T	= Temperature

I. INTRODUCTION

REJECTING heat is a critical requirement for any space vehicle or habitat. For certain mission scenarios, a sublimator provides an attractive option for heat rejection. For example, a sublimator can be used to supplement radiators for handling peak heat loads, or a sublimator can be used exclusively for heat rejection in warm thermal environments where the use of radiators is unfeasible. A sublimator rejects heat by using the process of sublimation, which is when a substance, such as water, changes from the solid phase directly to the vapor phase.

¹ Project Engineer, Crew and Thermal Systems Division, 2101 Nasa Road 1, EC2

² Thermal Systems Engineer, Crew and Thermal Systems Division, 2101 Nasa Road 1, EC2

³ Senior Aerospace Engineer, 1120 NASA Parkway, Suite 505, AIAA member.

Sublimators have been used for heat rejection in a variety of space applications, such as the Apollo Lunar Module and the Extravehicular Mobility Unit (EMU).

An example of where a thermal environment can change and reduce the heat rejection capability of a radiator occurs for a vehicle in Low Lunar Orbit (LLO). Lunar surface temperatures range from 400 Kelvin at the sub solar point to less than 100 Kelvin on the dark side as shown in Figure 1. Due to this large change in Lunar surface temperature, a vehicle’s radiator is subjected to a wide variation in incident infrared heat flux. Closer to the sub solar point, the radiator is unable to achieve the desired set point temperature of a vehicle; therefore, the vehicle must rely on a Supplemental Heat Rejection Device (SHReD) such as a sublimator or phase change material heat exchanger (PCMHX). Sublimators are considered to be the most mass efficient for short mission durations when compared to PCMHX. A PCMHX would be more efficient for longer mission phases because they do not require a consumable. Figure 2 shows the radiator capability, sublimator requirement, and vehicle requirement for an example spacecraft during a two-hour LLO with a beta angle of zero degrees. In this figure, the sublimator requirement is simply the difference between the vehicle heat rejection requirement and the radiator capability. For the majority of the orbit, the sublimator heat rejection requirement drops to zero due to the ability of the vehicle’s radiator to reject all of the vehicle waste heat (i.e., the radiator capability exceeds the heat rejection requirement for the majority of the orbit). A sublimator has never been used to provide heat rejection in a cyclic fashion.

Previous testing¹ showed sublimator inefficiencies at startup. However, some conflicting trends were inconclusive, and recommendations were made to improve the test results. This paper describes the follow-on testing and its results. These results are valuable for understanding general sublimator performance under transient heat loads. However, it is important to note that this paper is not to be taken as a point design to quantify the amount of water needed by a sublimator if used in this scenario. For this, a flight-like sublimator would need to be tested using the same methods discussed in this and previous papers referenced herein.

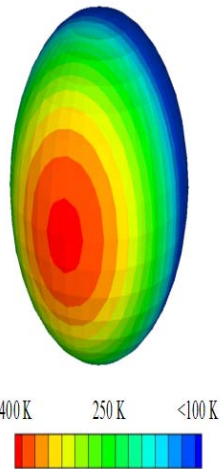

Figure 1. Spatial Temperature Distribution of Lunar Surface

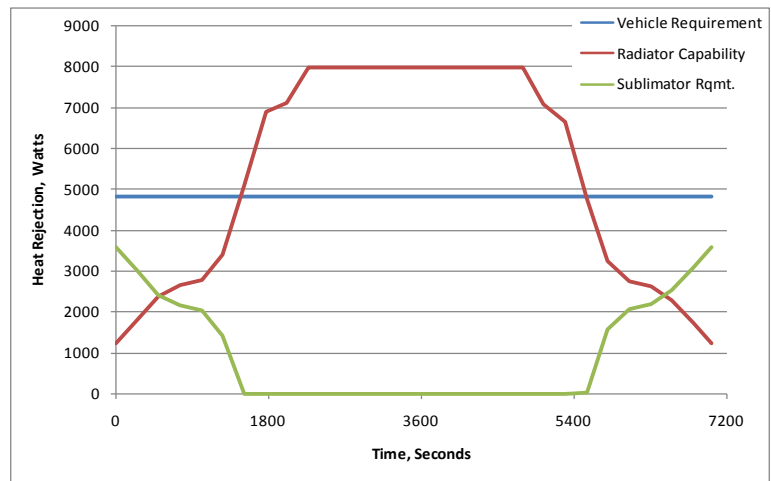

Figure 2 Radiator capability, sublimator requirement, and vehicle heat rejection requirement for an example spacecraft in Low Lunar Orbit.

II. SUBLIMATOR TEST LOOP ARCHITECTURE

For this study, three architectures were investigated for the inclusion of a sublimator into a flight system, as discussed in a previous paper.² These architectures resulted in a test loop configuration that allowed for varying inlet temperatures and flow rates of the coolant into the sublimator. Figure 3 is the schematic used to assemble the coolant side of the test system for the sublimator. While the chiller labeled “HX-750” in Figure 3 was used to provide the cold coolant temperatures, the combination of a liquid/liquid heat exchanger and heater cart (labeled “CIS Hot Chiller”) was used to vary the temperature into the sublimator. Three-way valve 1 and thermocouple 3 in the schematic were used to control the temperature into the sublimator while three-way valve 2 and flow meter 2 were used to control the flowrate into the sublimator.

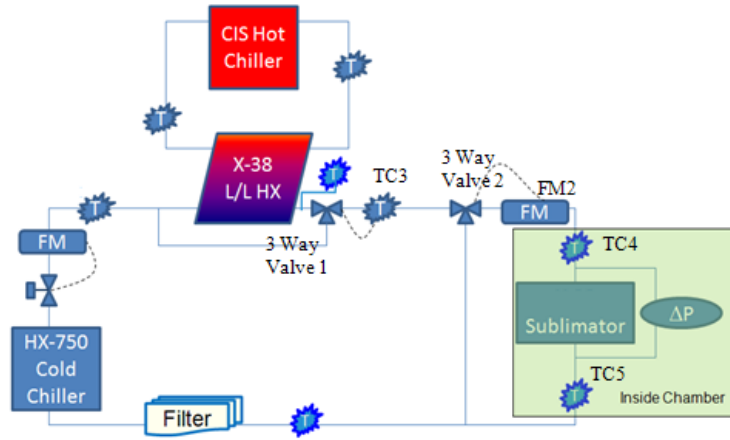

Figure 3. Coolant Test Loop Schematic for Transient and Steady State Sublimator Testing

The feedwater loop for sublimator testing is shown in Figure 4. The loop architecture is a heritage system used in previous sublimator testing.¹ The valve titled *feedwater* in the schematic was open/closed to enable/disable the feedwater into the sublimator.

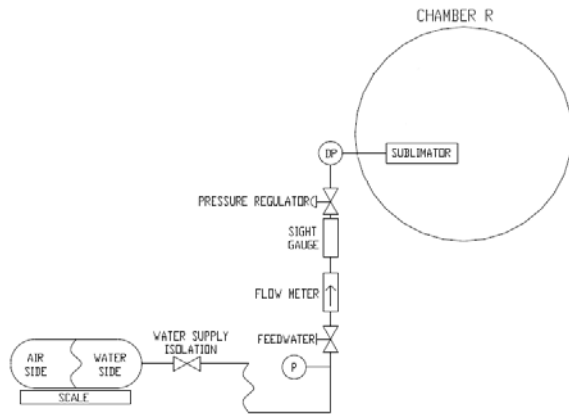

Figure 4. Sublimator feedwater schematic highlighting the isolation valve used to control feedwater flow to the sublimator

III. KEY PERFORMANCE PARAMETERS AND RELEVANT INSTRUMENTATION

For the purposes of this paper, a few components of the test setup were deemed critical for analysis of the test data.

1. Feedwater tank scale (Figure 4) – continuously measured and recorded the mass of the feedwater tank.
2. Thermocouples 4 and 5 (Figure 3) – measured the sublimator inlet and outlet coolant temperatures.
3. Flow meter 2 (Figure 3) – measured the coolant flow rate into the sublimator.

Two key performance parameters were derived for the transient sublimator testing. The first of these parameters is the heat dissipation of the sublimator. Due to the cyclical characteristic of the heat load, an integrated value was calculated of the applied heat load to obtain an overall energy load over a two hour orbit. During the orbit, the sublimator is subjected to a varying heat load for about 30 minutes with the remaining 90 minutes near zero heat load. The energy heat dissipation (Q_{orbit}) was calculated as follows:

$$Q_{orbit} = \int_0^{2hr} [\dot{m}C_p(T_{in} - T_{out})]dt$$

Equation 1

In the preceding equation, the variables were defined as:

\dot{m} : Coolant flow rate into the sublimator

C_p : Specific heat of the coolant used (50/50 mixture by weight of Propylene Glycol and Water)

T_{in} : The coolant temperature into the sublimator

T_{out} : The coolant temperature out of the sublimator

dt : Time interval

The second key performance parameter derived for the sublimator test was feedwater utilization (u). For steady state operation, utilization is simply a ratio of the ideal feedwater usage over the actual feedwater usage. The sublimator utilization is a measurement of how efficiently the sublimator used the feedwater for an applied heat load. Under ideal operating conditions, all of the feedwater supplied to the sublimator would freeze to solid ice and be sublimated to the ambient vacuum. In this situation, the ideal feedwater mass consumed over the two hour orbit would be expressed as:

$$m_i = \frac{Q_{orbit}}{\Delta h} \quad \text{Equation 2}$$

From Equation 2 Δh represents the change in enthalpy of the feedwater. The enthalpy change is closely approximated by $\Delta h = h_{fg}$, the heat of vaporization for water evaluated at the triple point temperature, 0°C. However, a slightly more accurate representation of Δh which was used for subsequent analysis is shown in Equation 3.

$$\Delta h = h_{fg} - C_{p,feedwater} \cdot (T_{feedwater,in} - 0^\circ C) \quad \text{Equation 3}$$

In order to assess the efficiency of feedwater usage by the sublimator, a parameter referred to as the Orbit Averaged Feedwater Utilization (OAFU) was defined. The OAFU is a measurement of how effectively the sublimator uses the consumable feedwater for an applied heat load over a two hour orbit. OAFU is calculated as the following:

$$OAFU = \frac{m_i}{m_a} \quad \text{Equation 4}$$

In Equation 4, m_a represents the actual amount of feedwater used by the sublimator over a single orbit. It is determined using data from the aforementioned feedwater weight scale. If all of the feedwater was being sublimated and contributing to the heat rejection, OAFU would be equal to unity. A value less than unity occurred when more feedwater was being sent to the sublimator than necessary to efficiently dissipate the measured heat load.

IV. QUANTIFICATION OF SUBLIMATOR FEEDWATER PERFORMANCE

One of the test objectives was to quantify the relationship between the timing of the feedwater (FW) isolation valve and the sublimator's OAFU. One possibility to consider is to keep the feedwater isolation valve open for the entire orbit. During the periods of zero heat load on the sublimator, just as it does during normal operation, the presence of the ice layer in the sublimator would prevent the feedwater from rushing out into space. However, even without an active heat load applied to the sublimator, the ice layer is still exposed to space vacuum, and would therefore continue to sublimate, possibly wasting feedwater and lowering the OAFU. To avoid this, the feedwater isolation valve could be closed before the transient heat load goes to zero in an attempt to sublimate away some or all of the feedwater remaining in the sublimator so that the feedwater reservoir is empty during the periods of zero applied heat load. Analysis showed that if the feedwater supply was stopped to the sublimator during a heating cycle, it would take multiple simulated orbits to sublimate the amount of water in the sublimator reservoir.

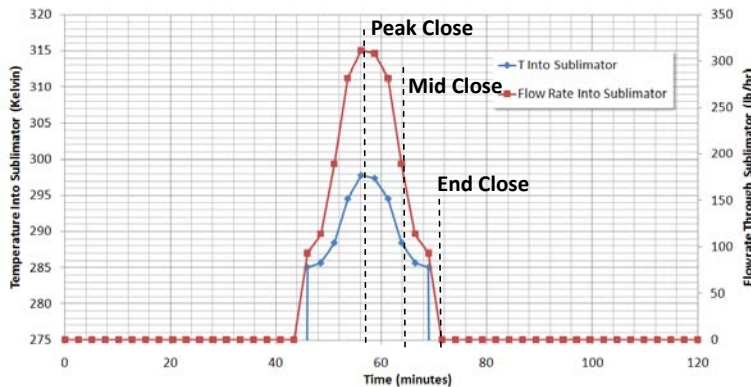

Figure 5. Sublimator coolant flowrate and inlet temperature as a function of time. The figure also shows the valve timings considered for the transient sublimator tests.

A total of four different feedwater control scenarios were completed. This was to understand the sublimator's response to feedwater control and to determine whether there was a relationship between feedwater valve timing and the OAFU. Each scenario changed the time interval for which the feedwater supply was sent to the test coupon. The four test scenarios are summarized below. For additional clarity, a graphical representation is shown in Figure 5:

- No Close – Never close the feedwater supply valve during the simulate orbit
- End Close – Open and close feedwater supply valve at the beginning and end of each heating cycle.
- Mid Close – Open the feedwater supply valve at the beginning, and close the feedwater $\frac{3}{4}$ through a heating cycle
- Peak Close – Open the feedwater supply valve at the beginning, and close the feedwater supply half way through the heating cycle (of the four operating scenarios, this scenario would result in the largest removal of water from the feedwater reservoir)

V. TEST ARTICLES

The Contamination Insensitive Sublimator (CIS) was used for this year’s transient sublimator testing. Figure 7 shows a cross section of the CIS. Feedwater is fed through an orifice to layers of porous materials. The first layer consists of porous disks while the second layer is a porous plate. Since the porous plate is exposed to space vacuum (below the triple point), the water freezes. Heat from the neighboring thermal loop layer causes the ice to sublimate. The latent heat of vaporization is carried away by the resulting vapor.² Figure 6 is a picture of the CIS. The heat rejection requirement for all three sublimator configurations exceeded the capability of the CIS. This required the test conditions to be scaled down so that the CIS did not reach a breakthrough heat flux during test. A scaling factor of 0.43 (based on the relative heat rejection capabilities of the two sublimators) was multiplied by the coolant flow rate requirement set for the X-38 unit in all the transient scenarios. The new coolant flow rate and previously used coolant inlet temperatures to the sublimator were used to test the CIS under the same conditions.

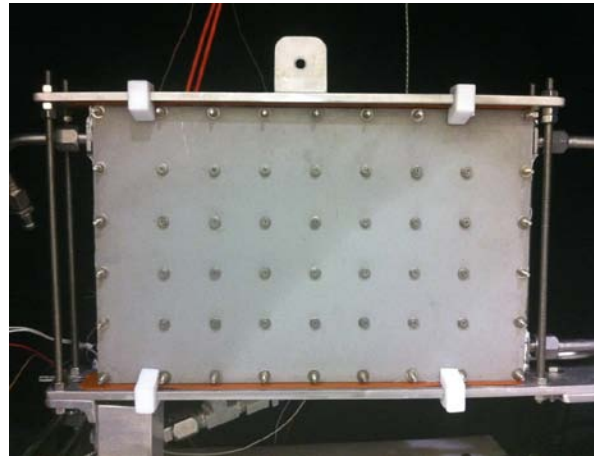

Figure 6. Contamination Insensitive Sublimator

VI. TRANSIENT SUBLIMATOR TEST MATRIX

Previous transient sublimator testing¹ provided great insight on previously made theories as well as established new theories that needed to be proven. The continuation of the transient sublimator test had a primary objective to prove/disprove theories previously made. Furthermore, the overall objective of the test program was to provide a broad based suggestion on sublimator operation when subjected to a transient, rather than a steady state, heat load. It is important to stress that the tests carried out in this test program pertained to sublimator performance of the Contamination Insensitive Sublimator. Test results may or may not change if a Hamilton Sundstrand Sublimator is tested under the same conditions.

To quantify the CIS’s performance, a four hour steady state test was performed

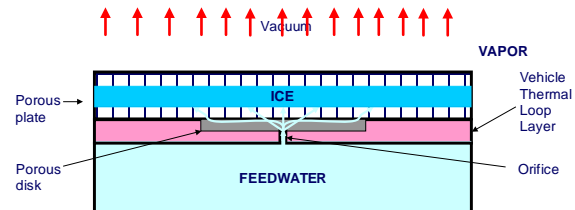

Figure 7. Contamination Insensitive Sublimator Plate Schematic

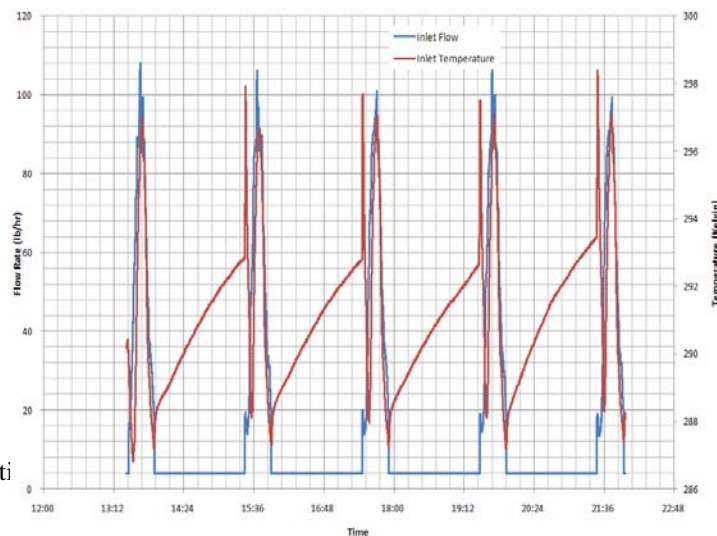

Figure 8. Sublimator Inlet Condition for Each Orbit

on the sublimator to establish a baseline for comparison to transient testing. The peak inlet conditions from last year's transient scenario 3 (27°C and 100 lb/hr) were used to perform steady state tests on the CIS. A steady state performance of the CIS over a 4 hour test concluded to have a utilization of 78%. This value was used as the baseline performance of the sublimator for comparison to subsequent transient and start up utilization testing of the Contamination Insensitive Sublimator.

The primary objective of sublimator testing under a transient heat load was to better understand if and when a steady and repeating performance can be achieved by running the tests for more than 8 hours (4 orbits). Last year's testing included only 4 orbits for each scenario, but it was not clear whether a steady repeating condition had been achieved. The aforementioned transient scenario 3 was run for the four different valve timing scenarios. Repeatability tests were run for the peak and no close valve timings. A minimum of 10 hours (5 orbits) were run for each valve scenario. Furthermore, to determine steady state performance a criteria was used where the last 3 OAFUs needed to be a value of $\pm 5\%$ from each other. A graph of the inlet conditions associated to Transient Scenario 3 can be seen in Figure 8. These inlet conditions were replicated for each valving scenario.

A compilation of the OAFUs of each valving scenario can be seen in Figure 9. All four valving scenarios specified in Section 4 were tested to at least 5 orbits. Each test was run to the quasi-steady state requirement referenced above. The peak and no close valving scenarios were tested twice for repeatability. Table 1 is a summary of the results of each test. The orbit averaged feedwater utilization reported in the table is an average of the last three orbit OAFUs.

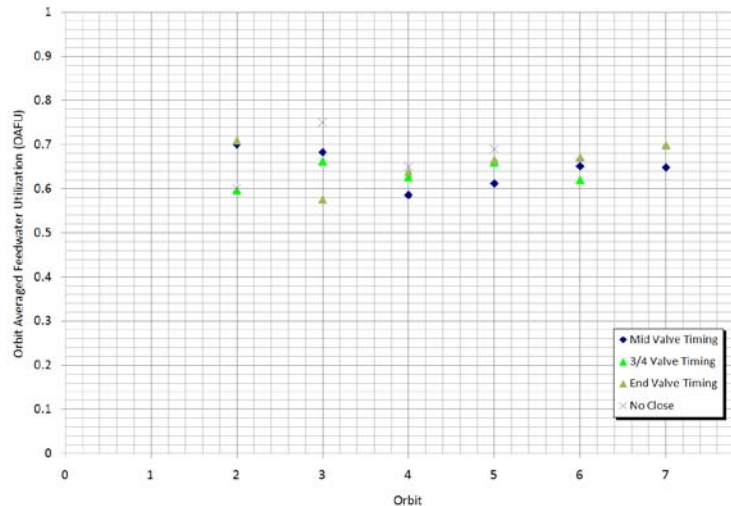

Figure 9. Compilation of OAFUs for Each Valving Scenario.

Figure 10 is a graphical representation of the average of each of the valving scenarios specified above. A general increasing trend is noticed as the feedwater is less and less controlled to the sublimator. The highest tested utilization of the sublimator under transient operation was for the no close valving scenario. This test allows for a theory that a constant feedwater supply to the sublimator is advantageous over some form of control. Nonetheless, it should also be noted that the OAFUs for each valve scenario, including no close, are below that of the sublimator's steady state performance of 78%.

Table 1. OAFU Summary for Each Valve Timing

Valving Scenario	Orbit Averaged Feedwater Utilization
Peak Valve	64%
Peak Valve (repeat)	61%
Mid Valve	64%
End Valve	68%
No Close	70%
No Close (repeat)	67%

Figure 11 points to a decreased utilization of a sublimator for all causes of feedwater control to the sublimator in transient operation when compared to steady state. It should be noted that this data is specifically for the performance of the Contamination Insensitive Sublimator. Numerous steady state tests have been performed on the CIS to date. All tests, for the same inlet conditions, show a general decreasing trend in CIS performance over time, which is likely due to contamination of the porous plate. This trend can be seen in Figure 12. The last steady state test day of 4/25/2011 shows a steady state utilization of 78%. This test was performed after transient sublimator testing.

The decrease of the OAFU below the steady state utilization value for all valve timing scenarios is likely to be caused by parasitic heat leaking into the sublimator. For the No Close scenario, the decrease from a steady state utilization of 78% to an OAFU of 69% corresponds to an extra 0.037 kg of water being sublimated. This is equivalent to heat leaking into the sublimator at a rate of 13 W over the ~1.5 hour period of zero active heat load. Furthermore, during a zero active heat load test from last year¹, 0.09 kg of water was sublimated over a 4 hour period, which is a similar rate of sublimation. Finally, a bounding calculation of radiative heat transfer to a

sublimator at 0°C from vacuum chamber walls at 35°C and an assumed emissivity of 1 results in a radiative heat transfer rate of 31 W, which again is consistent with the observations from the zero heat load portions of the current testing.

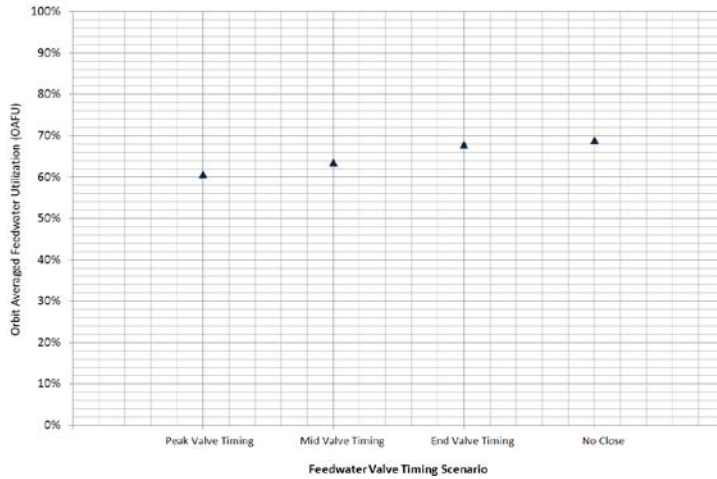

Figure 10. OAFU Comparison of Each Valving Scenario

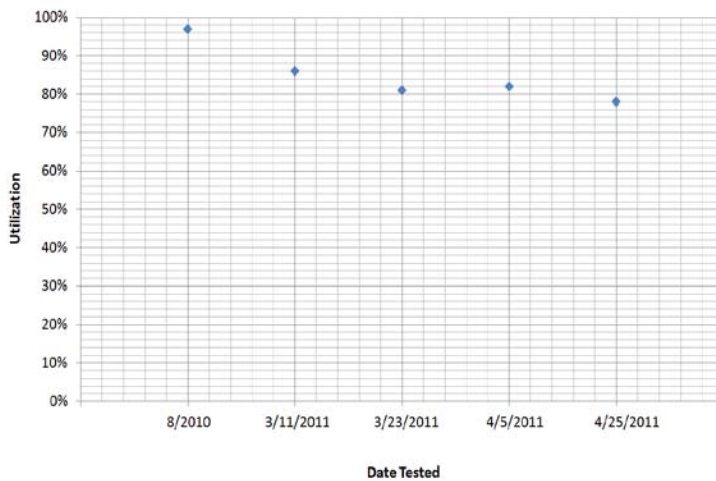

Figure 11. Steady State Utilization of Contamination Insensitive Sublimator

While the overall decrease of OAFU below steady state utilization is likely due to parasitic heat leak, it is thought that the *trend* of decreasing OAFU with increased feedwater control observed in Figure 11 is due to inefficiencies associated with sublimator startup and filling of a depleted feedwater reservoir. A series of “Startup Utilization” tests was conducted in an effort to better understand this trend, as explained in the next section.

VII. TRANSIENT SUBLIMATOR TEST – STARTUP UTILIZATION TESTING

To better understand sublimator efficiency with respect to feedwater deprivation, a suite of startup utilization tests was conducted last year.¹ The test plan called for sublimator operation at a steady state heat load (close to the peak heat loads during transient tests). Once the sublimator had reached steady state operation, the sublimator would be deprived of feedwater for a predetermined time interval, while maintaining constant coolant flow through it. The test team had made recommendations to improve the way the test was performed. These recommendations, outlined below, were used to rerun start up utilization tests this year:

A true value of utilization for transient operation of a sublimator cannot be recommended until a flight sublimator is tested under these conditions. Recommendations are as follows:

- Never run the sublimator at a negative heat load
- Assess flight like sublimator at zero heat loads
 - Actual performance of a sublimator at zero heat load on a vehicle will also be dependent upon its installation in the vehicle and operational scenarios of the vehicle. These factors will affect the parasitic heat leaks into the sublimator at zero active heat loads.
- Constant feedwater supply to a sublimator is advantageous over any form of feedwater control from the standpoint of feedwater utilization.
 - This is highly dependent on the zero heat load test.
 - No feedwater control comes with the risk of feedwater freezing expansion causing damage to the hardware. The CIS has been tested under extended periods of zero heat load without any sign of damage, indicating that the design of the CIS may be inherently more freeze tolerant. However, a more extensive test program would be needed to more rigorously assess freeze tolerance.
- Use the test program specified in this paper to assess a more replicative sublimator of flight design to understand true OAFU for various valving scenarios
- Assume some conservative lower estimate for utilization of the sublimator if it is intended to be used in transient operations.

- Run start up utilization tests for refined feedwater deprivation time intervals (1 min, 2 min, 3 min, 4 min, 5 min, 10 min, 20 min, 30 min, 40 min, hot start).
- Allow for adequate time for steady state operation of the sublimator before depriving the sublimator of feedwater. Previously coolant outlet temperatures were used to assess sublimator steady state. This time feedwater usage was used to ensure that the sublimator had reached a steady state operation

In general the sublimator was maintained at a steady state operation for about 2 hours before any feedwater deprivation time interval was applied to it. A representation of the start up tests can be seen in Figure 13. The heat rejection, which is a function of flow rate, specific heat, and temperature delta of the inlet and outlet coolant, is plotted on the left ordinate while the feedwater usage of the sublimator is plotted on the right ordinate.

As the sublimator is being deprived of feedwater the outlet temperature of the coolant increases with time. This results in a decreased heat rejection, as seen in Figure 12. This phenomenon was repeated for every feedwater deprivation interval. For each interval, a start up utilization was calculated for the time when the feedwater valve was opened to 15 minutes after the feedwater valve was opened.

Figure 13 is a representation of feedwater utilization of the sublimator for startup testing. The graph plots utilization of the sublimator over increasing intervals for each feedwater deprivation interval. For each feedwater deprivation period, utilization was calculated for increasing 15 minute intervals. This means utilization was calculated for intervals from 0 to 15 minutes, 0 to 30 minutes, etc. until the feedwater valve was closed again for the next deprivation interval. The figure shows that each of the feedwater deprivation intervals asymptotically approaches the steady state utilization of 78%. Furthermore, the initial 900 second (15 minute) interval utilization decreases for each interval as the sublimator is deprived of water for longer durations.

Another graph of each start up utilization can be seen in Figure 14. The green data points are the initial 900-second start up utilizations for each feedwater deprivation interval. These utilizations are referenced to the right ordinate. The red and blue data points are the feedwater usages for each feedwater deprivation over the first 15 minutes from when the feedwater valve was reopened. These data points are referenced to the left ordinate.

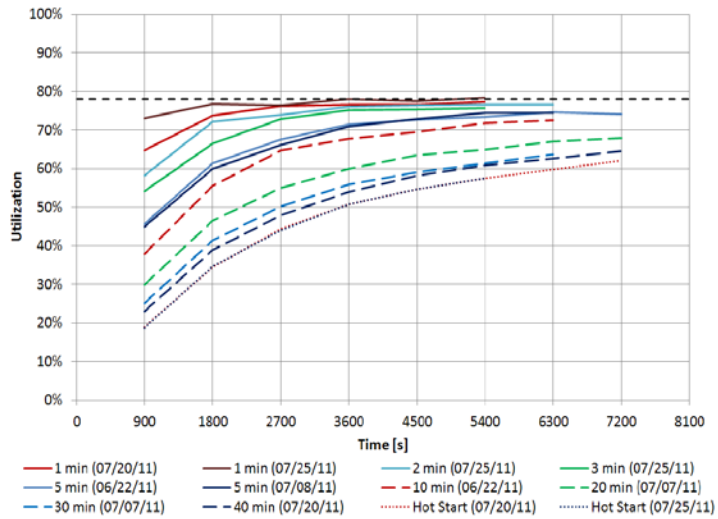
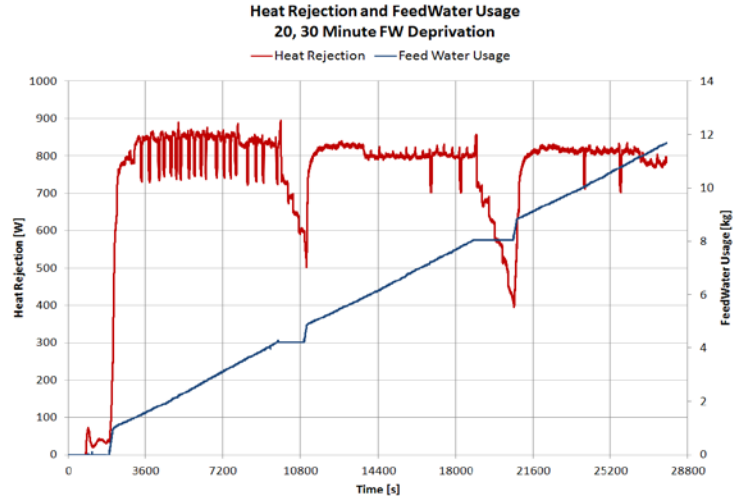

Figure 13. Startup Utilization Over Increasing 15 Minute Intervals

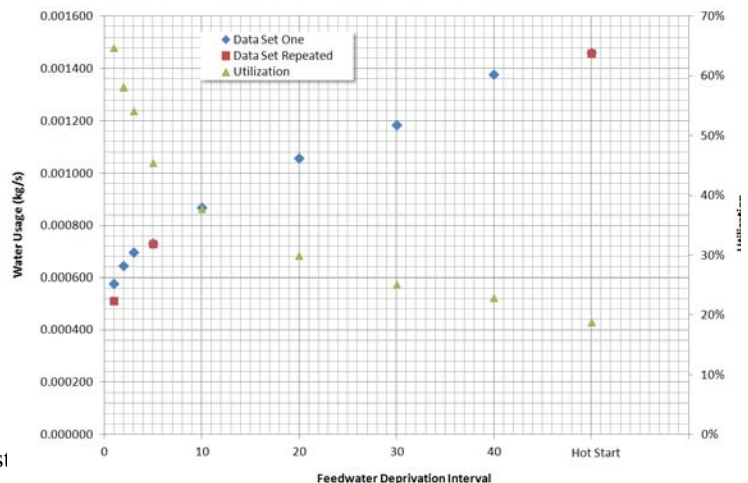

Figure 14. Water Usage and Start Up Utilizations Over First 15 Minutes for Each Feedwater Deprivation Interval

For the shorter duration deprivation intervals, a smaller amount of water is used in the first 15 minutes when compared to the longer duration intervals. It is important to note that the steady state feedwater usage is about 0.004 kg/s. As the feedwater usage increases the start up utilization of the sublimator decreases. The graph shows how the feedwater usage asymptotically approaches steady state usage as the deprivation interval decreases. On the other hand, as more and more feedwater is deprived from the sublimator, the utilization asymptotically approaches a hot start. A hot start is when coolant is sent into the sublimator until the inlet and outlet temperatures are the same. Once this criterion is met, feedwater is introduced to the sublimator. In all, the graphs in Figure 13 and 14 show how as more and more feedwater is deprived from the sublimator, the utilization decreases.

Startup utilizations were calculated starting at a point when the feedwater valve was reopened after a certain feedwater deprivation interval. The filling of the depleted feedwater reservoir in the sublimator results in decreased startup utilization. The feedwater that was sublimated during the time period when the feedwater valve was closed was the result of heat rejection by the sublimator. Therefore, not all of the depleted water was wasted. In order to rigorously explain the relationship between feedwater reservoir depletion and OAFU, additional calculations are needed to determine how much feedwater is actually wasted.

Figure 15 shows a plot of heat rejection and feedwater usage for the 30-minute-interval startup utilization test. Note that the “actual” feedwater usage represents the feedwater coming out of the tank. A calculation of the “ideal” feedwater coming out of the sublimator is made assuming the steady state utilization and is also shown on the graph. The assumed steady state utilization used for the “ideal” feedwater curve was the calculated steady state utilization 30 minutes prior to closing the feedwater valve. It can be seen on the graph at a time of approximately 60 minutes when the feedwater valve is reopened that the blue line representing the actual feedwater usage rises above the ideal feedwater usage, indicating the possibility of water being wasted to filling of the depleted reservoir. However, as time goes on the actual and ideal water usage lines eventually coincide, indicating no net feedwater being wasted.

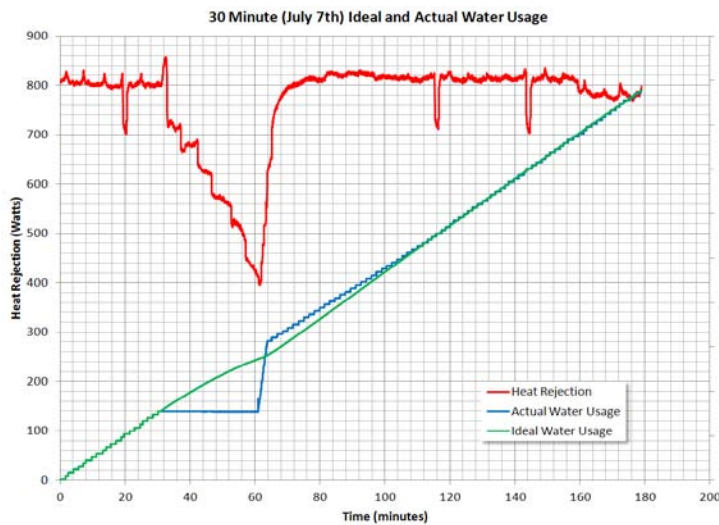

Figure 15. Sublimator Heat Rejection, Actual Water Usage, and Ideal Water Usage for 30-Minute-Interval Start Up Testing

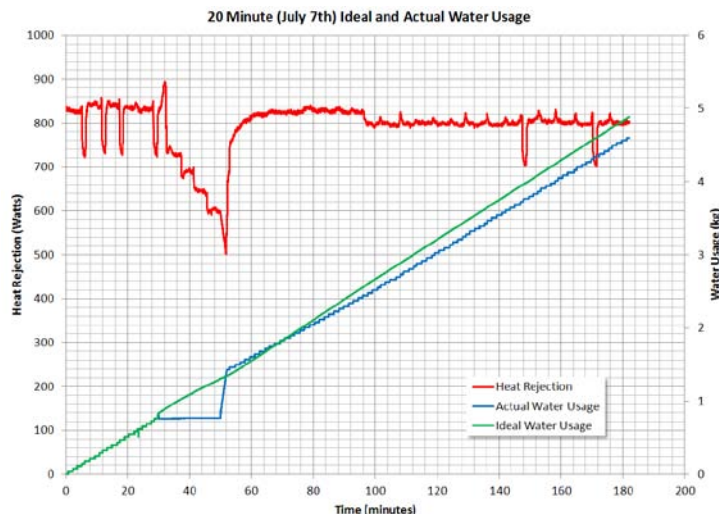

Figure 16. Sublimator Heat Rejection, Actual Water Usage, and Ideal Water Usage for 20-Minute-Interval Start Up Testing

Similar plots were made for all of the other feedwater deprivation intervals. In all cases, the actual water usage line did rise above the ideal water usage line at the time the valve was re-opened, but beyond that no single trend was observed. In some cases, the actual water usage line would remain above the ideal line, indicating a net amount of wasted feedwater. In other cases, such as shown in Figure 16, the actual water usage line would end up dipping below the ideal line, indicating that closing and opening the feedwater valve somehow resulted in more efficient feedwater usage than if the sublimator had just continued operating in steady state. To further complicate matters, the net effect is very sensitive to the steady state utilization used for the ideal usage calculations. A change of only 1-2% for the assumed steady-state utilization could often mean the difference between the ideal water usage line being above or below the actual water usage line. Therefore it is difficult to draw any definite conclusions from these startup utilization tests that can explain the OAFU trend seen in Figure 10.

CONCLUSIONS

Traditionally sublimators have been used as a short duration heat rejection device for steady state heat loads. In general sublimators are a very efficient evaporative heat rejection device that is self controlling and has no moving parts. A novel approach to using a sublimator would be as a supplemental heat rejection device, SHReD. This operational scenario would have the sublimator operating at a cyclical transient heat load with a possible design point for a maximum steady state heat load. This operation was investigated by Orion and Altair for their Low Lunar Orbit and Lunar Ascent phases of the mission. A risk that needed to be mitigated for this operational scenario was the reduced utilization of the sublimator when used as a transient heat rejection device. The Advanced Thermal Technologies Team planned and executed a rigorous test plan to understand a sublimator's response to transient heat loads as well as investigation of sublimator inefficiencies due to start ups.

Through this rigorous test program it was concluded that a constant feedwater supply to the sublimator was advantageous over a controlled feedwater supply for cyclical transient heat loads. It should be stressed though that the utilization of the sublimator for constant feedwater supply was still considerably less than that of its steady state utilization. Therefore, the test team does recommend to estimate a conservatively low sublimator efficiency when sizing for a sublimator at transient heat loads. A true value for the efficiency cannot be recommended until a flight like sublimator is tested under these same conditions. Furthermore, although it is recommended to not run the sublimator at negative heat loads, the test team cannot provide a definitive answer on whether or not zero heat loads are ok. The Contamination Insensitive Sublimator did indicate some freeze tolerance at zero heat loads, but this cannot be said for other flight like designs of a sublimator. Again, tests needed to be run on a flight like sublimator at zero heat loads to prove or disprove this theory.

In the process of testing the sublimator under transient loads for various feedwater control scenarios, the test team found that the sublimator may have certain inefficiencies at start up resulting in poor performance. Therefore, start up utilization tests were conducted by the team with the thought that it may help in explaining why the sublimator was inefficient when only the necessary amount of feedwater was sent to it. The tests did indicate that as more and more water is deprived from the sublimator, the sublimator uses more water to reestablish steady state efficiency. Although the test did provide insight into sublimator performance, it did not provide definitive answers on why the utilization was poor during transient sublimator testing for controlled feedwater amounts to the sublimator.

In all the test team recommends the use of a sublimator as a transient short duration supplemental heat rejection device. The sublimator should be run as would be for steady state operation with the caveat to expect lower utilizations than that of steady state operations. This general trend was observed while testing the CIS under transient conditions. However, to obtain quantitative values for sublimator feedwater efficiency and tolerance to zero heat loads for a specific sublimator design for a flight vehicle, the particular flight like sublimator should be tested using this test program.

ACKNOWLEDGEMENTS

The test team would like to thank all test support engineers including Hung Le, Aaron Colunga, Monse Lozano, and Kevin Ehlinger.

REFERENCES

¹Sheth, R. B., Stephan, R. A., "Experimental Investigation of Transient Sublimator Performance," AIAA-2011-5187, 41st International Conference on Environmental Systems, Portland, OR, 2011.

²Leimkuehler, T. O., Sheth, R., Stephan, R. A., "Investigation of Transient Sublimator Performance," AIAA-2010-6231, 40th International Conference on Environmental Systems, Barcelona, Spain, 2010.

³Leimkuehler, T. O., Stephan, R. A., "Development and Testing of the Contaminant Insensitive Sublimator," SAE 2007-01-3203, 36th International Conference on Environmental Systems, Chicago, IL, 2007.

⁴Tongue, S., Dingell, C., "The Porous Plate Sublimator as the X-38/CRV (Crew Return Vehicle) Orbital Heat Sink," 29th International Conference on Environmental Systems, SAE Paper 1999-01-2004, 1999.