

▶ **Fundamental Ice Crystal Accretion Physics Studies**

▶ **ABSTRACT**

- ▶ Due to numerous engine power-loss events associated with high-altitude convective weather, ice accretion within an engine due to ice-crystal ingestion is being investigated. The National Aeronautics and Space Administration (NASA) and the National Research Council (NRC) of Canada are starting to examine the physical mechanisms of ice accretion on surfaces exposed to ice-crystal and mixed-phase conditions. In November 2010, two weeks of testing occurred at the NRC Research Altitude Facility utilizing a single wedge-type airfoil designed to facilitate fundamental studies while retaining critical features of a compressor stator blade or guide vane. The airfoil was placed in the NRC cascade wind tunnel for both aerodynamic and icing tests. Aerodynamic testing showed excellent agreement compared with CFD data on the icing pressure surface and allowed calculation of heat transfer coefficients at various airfoil locations. Icing tests were performed at Mach numbers of 0.2 to 0.3, total pressures from 93 to 45 kPa, and total temperatures from 5 to 15°C. Ice and liquid water contents ranged up to 20 and 3 g/m³, respectively. The ice appeared well adhered to the surface in the lowest pressure tests (45 kPa) and, in a particular case, showed continuous leading-edge ice growth to a thickness greater than 15 millimeters in 3 minutes. Such widespread deposits were not observed in the highest pressure tests, where the accretions were limited to a small area around the leading edge. The suction surface was typically ice-free in the tests at high pressure, but not at low pressure. The icing behavior at high and low pressure appeared to be correlated with the wet-bulb temperature, which was estimated to be above 0°C in tests at 93 kPa and below 0°C in tests at lower pressure, the latter enhanced by more evaporative cooling of water. The authors believe that the large ice accretions observed in the low pressure tests would undoubtedly cause the aerodynamic performance of a compressor component such as a stator blade to degrade significantly, and could damage downstream components if shed.

Fundamental Ice Crystal Accretion Physics Studies

Tom Currie, Danny Knezevici

Dan Fuleki

National Research Council of Canada

Gas Turbine Laboratory, Icing Group

Peter M. Struk, Andy P. Broeren

Jen-ching Tsao, Mario Vargas, William Wright

NASA Glenn Research Center

Icing Branch

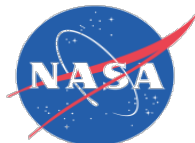

SAE *International*™

2011-38-0018

Background

- ▶ Ingestion of atmospheric ice crystals by aircraft engines can cause ice to accrete on internal components , leading to rollback, flameout, mechanical damage, etc.
- ▶ Ice crystal icing observed in experiments at NRC with flat plate, inter-compressor S-duct (with strut), but understanding/verification of even basic physics still incomplete
- ▶ Improved understanding of physics required to develop simulation models and scaling laws/parameters

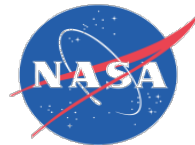

SAE *International*™

2011-38-0018

Fundamental Ice Crystal Physics Studies

Where Do Crystals Accrete?

- ▶ Some melting of crystals required
- ▶ → favors accretion several stages into compressor, on non-rotating components
- ▶ Accretion most likely on surfaces with:
 - cooling (e.g. by bypass air)
 - anchoring geometry (e.g. probe, bleed port)
 - low tangential velocity/shear, high collection efficiency (stagnation points)
- ▶ Cannot be more precise without answering the question

Why Do Crystals Accrete?

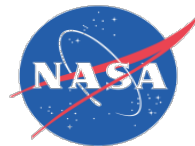
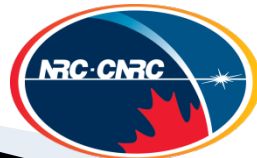
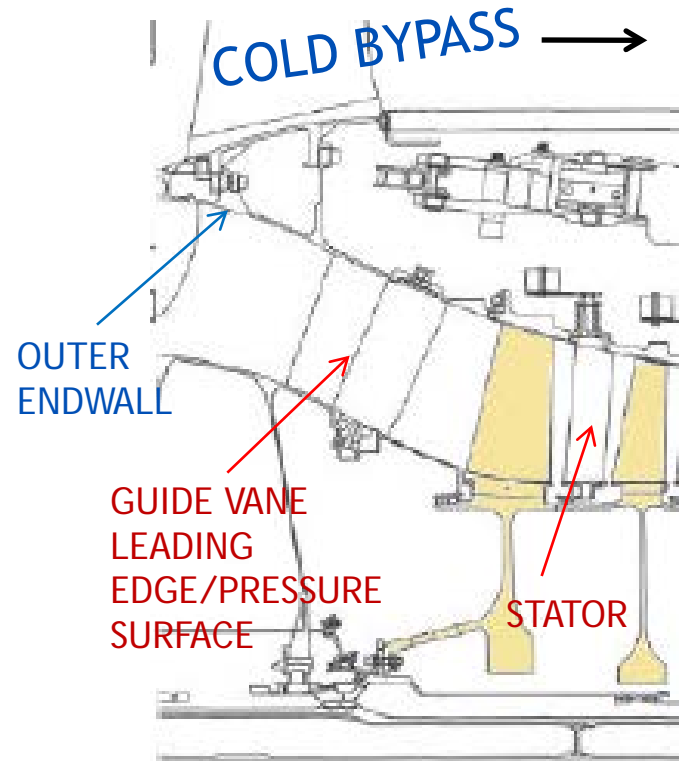

SAE *International*™

2011-38-0018

Fundamental Ice Crystal Physics Studies

Research Objectives

- ▶ Preliminary study of **why** crystals accrete
 - conditions/parameters governing accretion initiation and growth
- ▶ Determine accretion characteristics of a simple geometry (surface) over range of mixed-phase icing conditions
- ▶ Document time evolution of ice accretions - initiation, growth, shedding
- ▶ Obtain baseline heat transfer and aerodynamic characteristics for test geometry, without ice crystals or water spray
- ▶ No attempt to identify **where** crystals accrete - focus on identifying local parameters to be used with stage-by-stage calculations of aero-thermodynamic parameters, crystal melting, etc. to identify critical locations



SAE *International*[™]

2011-38-0018

Fundamental Ice Crystal Physics Studies

Test Surface Design Objectives

- ▶ Allow high (closer to normal) particle incidence angles, as expected for a stator pressure surface

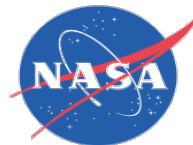
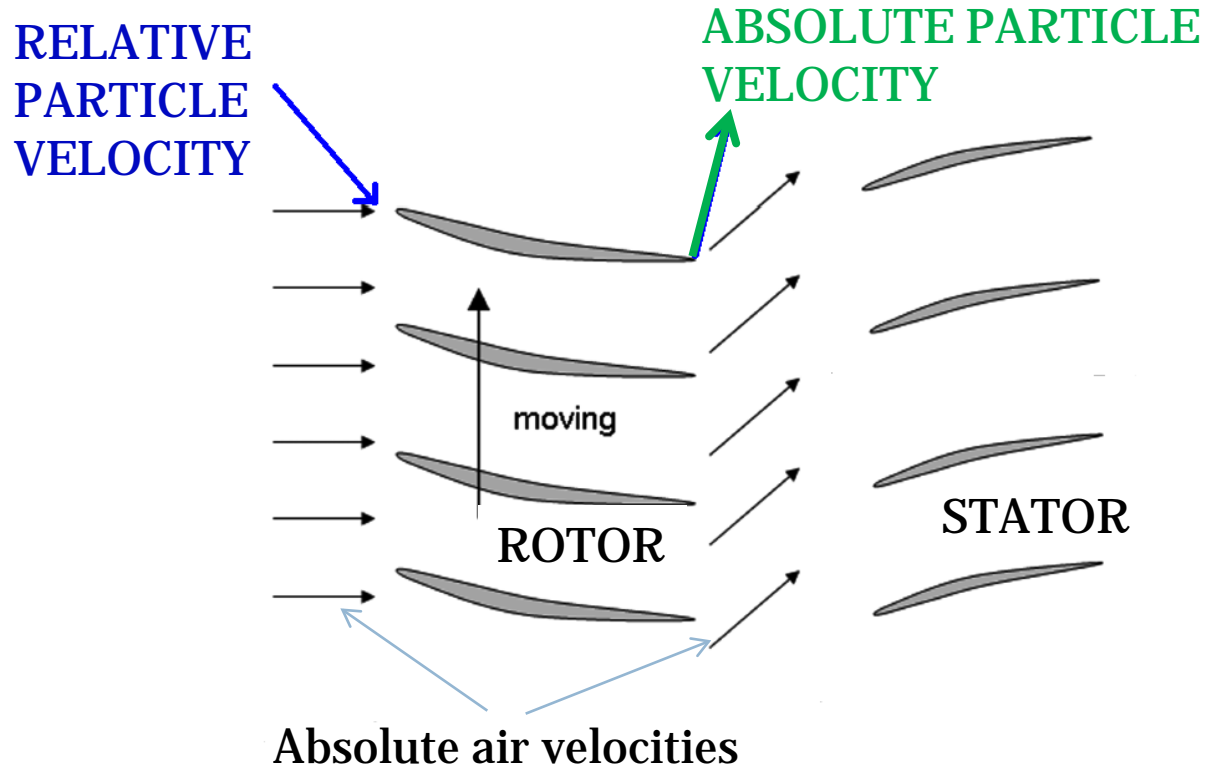

SAE *International*[™]

2011-38-0018

Fundamental Ice Crystal Physics Studies

Test Surface Design Objectives, cont'd

- ▶ Provide ~ 2D flow
- ▶ Have relatively sharp leading edge, characteristic of compressor blades
- ▶ No flow separation on clean geometry
- ▶ Flat icing surface to facilitate mounting surface instrumentation, back side heaters, etc.
- ▶ Provide adequate space behind test surface to allow attachment of heaters, compact transducers, etc
- ▶ Similar thermal boundary conditions to hollow Ti 6Al-4V compressor blade
- ▶ Material other than test surface ideally ice-phobic with low thermal conductivity

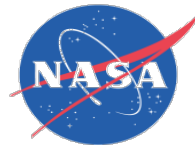

SAE *International*[™]

2011-38-0018

Fundamental Ice Crystal Physics Studies

Test Surface Design Objectives, cont'd

- ▶ Pressure surface of wedge airfoil forebody satisfied requirements

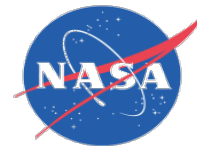
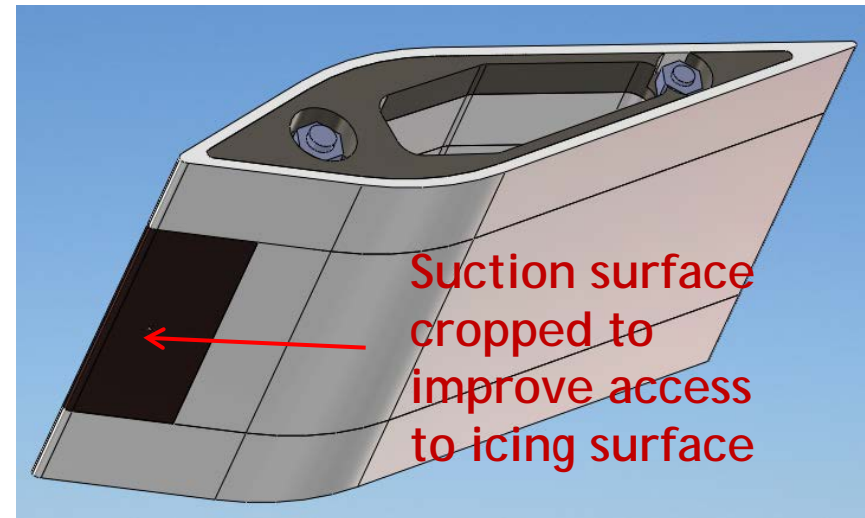
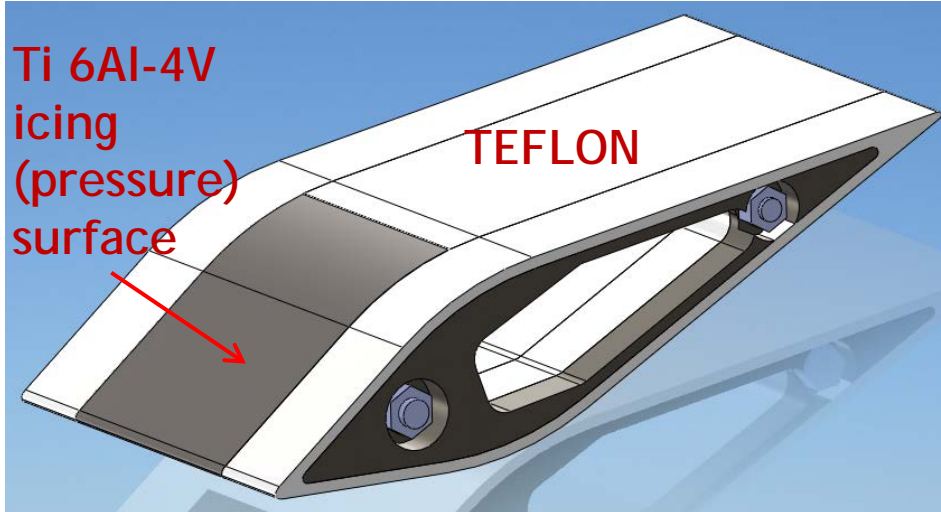

SAE *International*™

2011-38-0018

Fundamental Ice Crystal Physics Studies

Wedge Airfoil Geometric Parameters

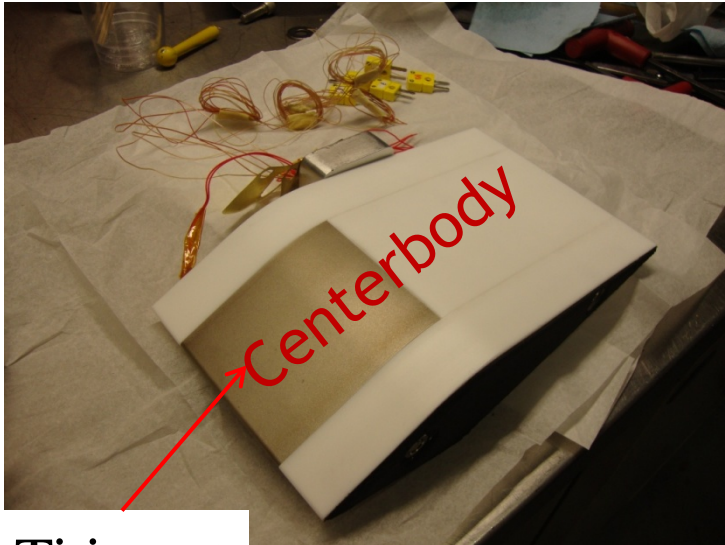

Ti insert

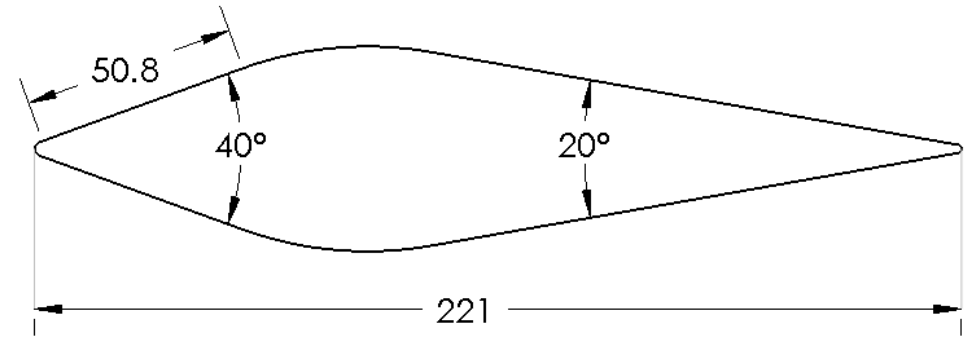
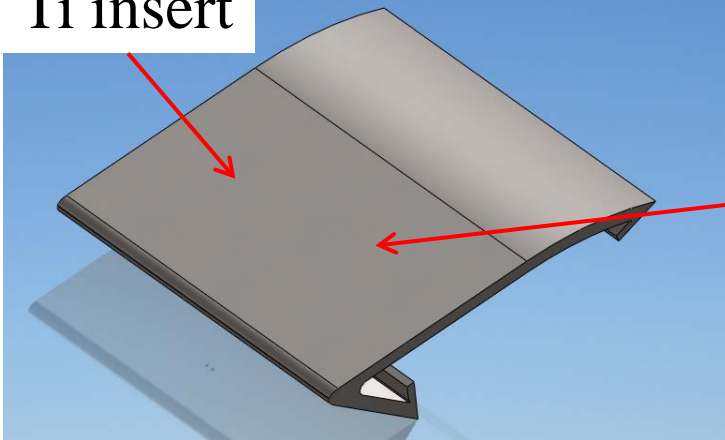

- Symmetrical
- chord = 221mm (8.7")
- max thickness = 22.2% chord
- 50.8mm (2") x 3.175mm (1/8" thick)
flat icing surface



SAE International™

2011-38-0018

Fundamental Ice Crystal Physics Studies

NRC Test Facility

- ▶ Tests conducted in an icing cascade tunnel located in NRC **R**esearch **A**ltitude **T**est **F**acility (RATFac) altitude chamber.

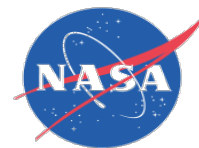
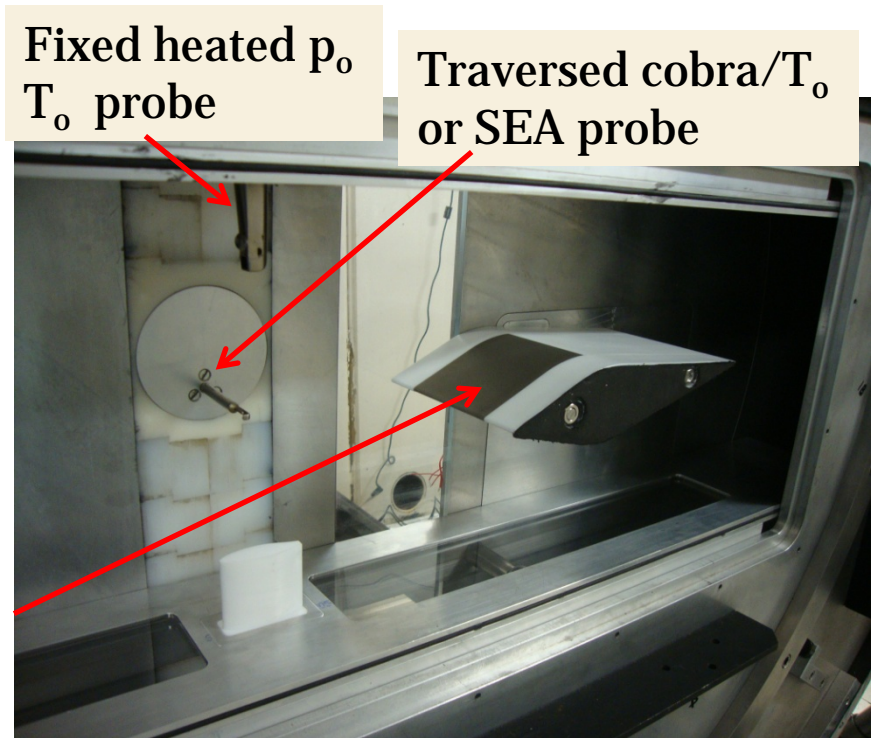
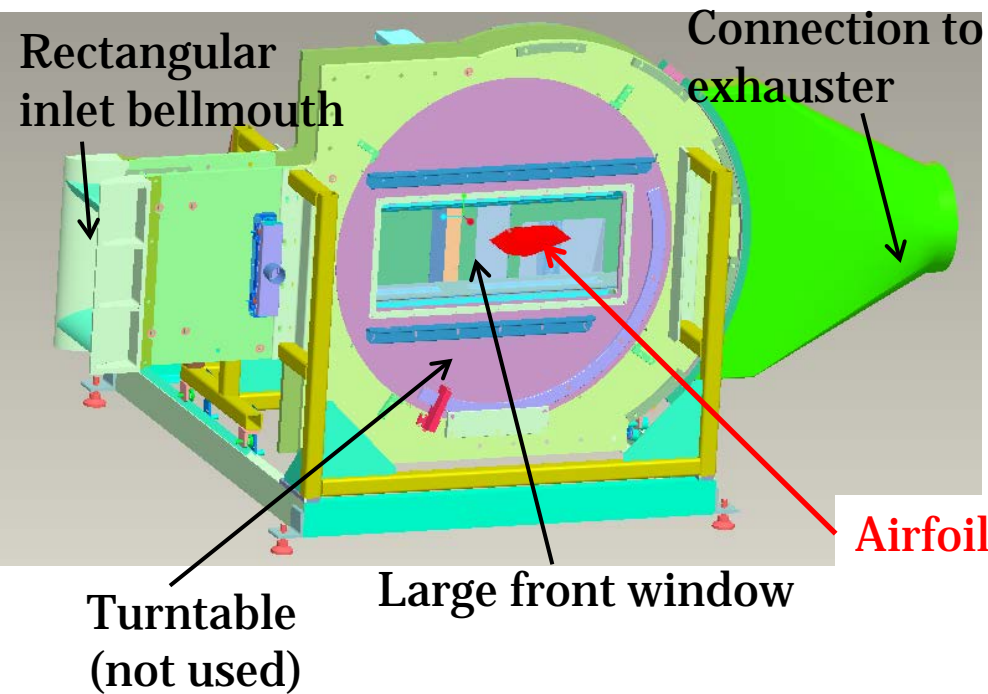

SAE International™

2011-38-0018

Fundamental Ice Crystal Physics Studies

NRC Test Facility, cont'd

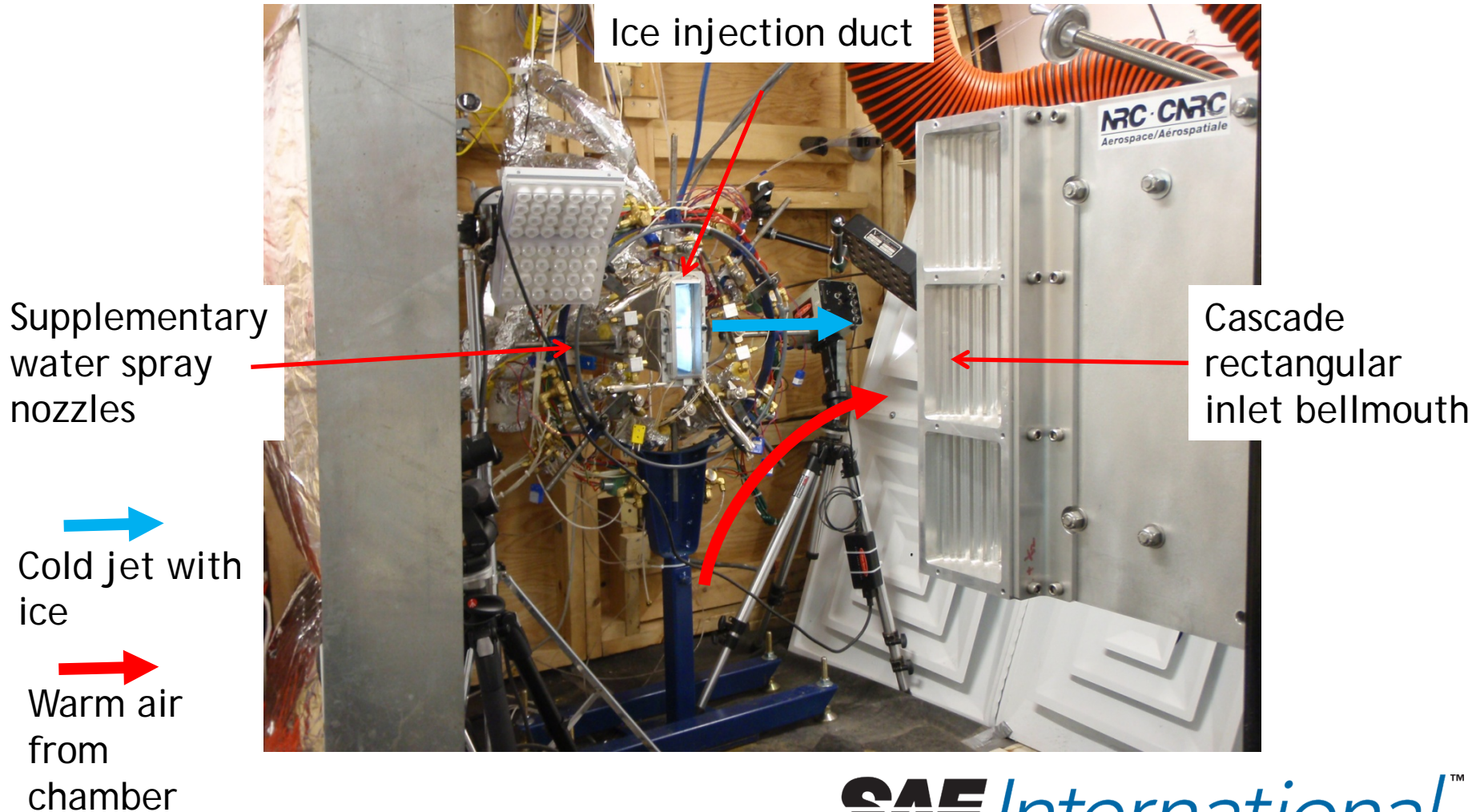

SAE *International*[™]

2011-38-0018

Fundamental Ice Crystal Physics Studies

Baseline (Clean Airfoil) Aerodynamic Tests

- ▶ Static pressure measurements to determine isentropic Mach number distribution and oil flow tests to check for flow separation
- ▶ Aluminum centerbody with 42 $\frac{1}{2}$ mm diameter static pressure taps at mid span replaced Ti insert

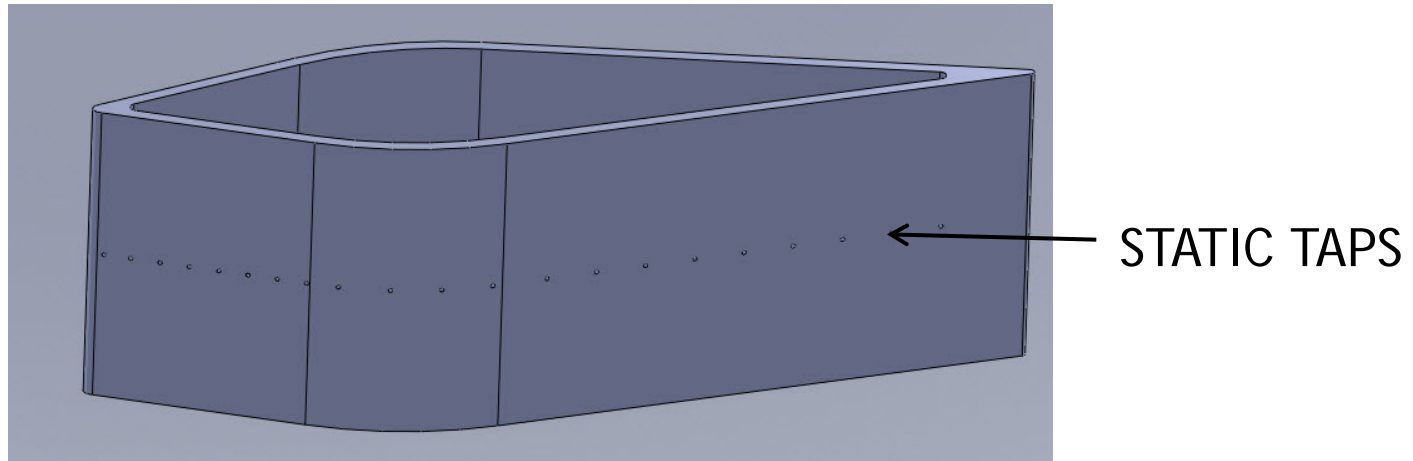

- ▶ Determined airfoil largely separation-free over required operating range, and flow over forebody pressure (icing) surface well-behaved

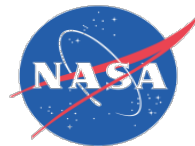
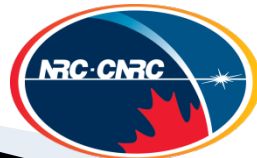

SAE *International*™

2011-38-0018

Fundamental Ice Crystal Physics Studies

Heat Transfer Tests

- ▶ Ti insert replaced with copper, heated with thin film heaters
- ▶ 5 type K thermocouples embedded in copper wall
- ▶ 4 thin film heat flux gauges on insert pressure surface
- ▶ T_o , M , turbulence parameters measured 150mm before leading edge
- ▶ Effect of gauge on heat flux corrected with CFD $\rightarrow q'' \rightarrow h = \frac{T_{wall} - T_{recovery}}{q''}$
- ▶ Tested at -6° AOA, 45 kPa (6.5psia)

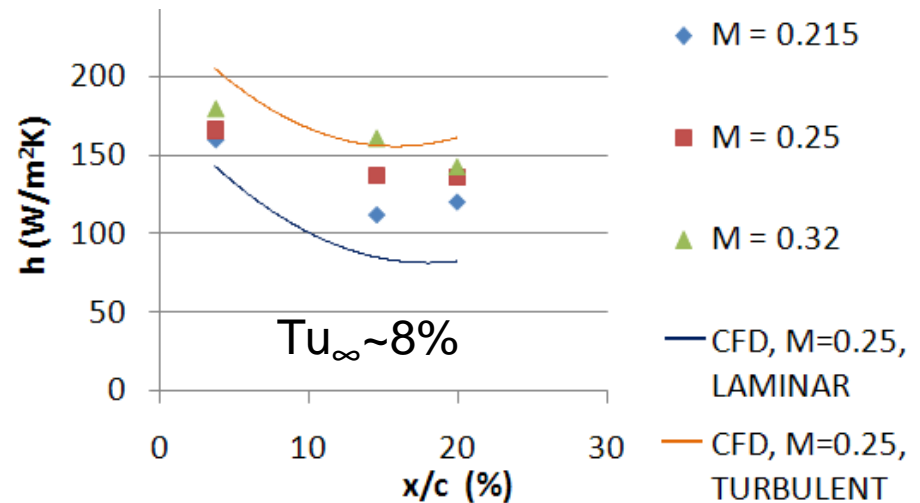
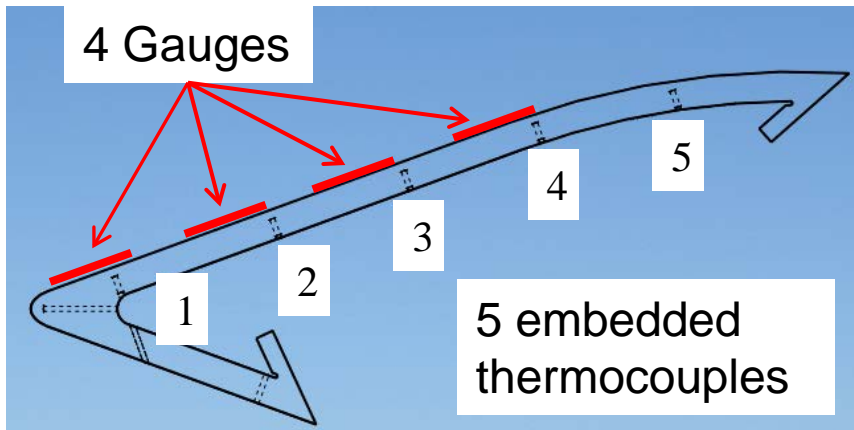

SAE International[™]

2011-38-0018

Fundamental Ice Crystal Physics Studies

Icing Tests

Controlled Parameters

- ▶ $M = 0.2$ (most tests) and 0.3
- ▶ $P_o = 45$ or 93kPa (6.5, 13.5 psia), most tests
- ▶ Total air temperature (TAT) above freezing ($5 \rightarrow 15^\circ\text{C}$)
- ▶ Injected IWC up to 20 g/m^3 (bulk) $\rightarrow IWC_i$
- ▶ Injected (supplemental) LWC up to $3\text{ g/m}^3 \rightarrow LWC_i$
- ▶ Angle of attack = -6° (nose down)
- ▶ MMD of ice particles fixed at $\sim 100 - 200\mu\text{m}$
- ▶ MVD of water droplets = $40\mu\text{m}$ (sea level calibration)

Parameters Measured or Calculated

- ▶ IWC, LWC measured with SEA multi-element probe 150mm upstream of airfoil $\rightarrow IWC_m, LWC_m$
- ▶ Wet bulb temperature TWB, calculated from mass balance on moisture entering cascade tunnel from altitude chamber (ambient) and ice injection pipe (dehumidified).

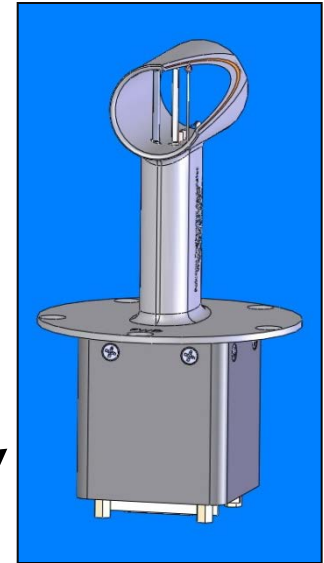

SAE International™

2011-38-0018

Fundamental Ice Crystal Physics Studies

Icing Tests

Parameters Measured or Calculated, cont'd

- ▶ Temperatures of icing surface, measured with 5 type K thermocouples
- ▶ Icing recorded with video/still cameras from 3 angles, front (perspective below) , side , top

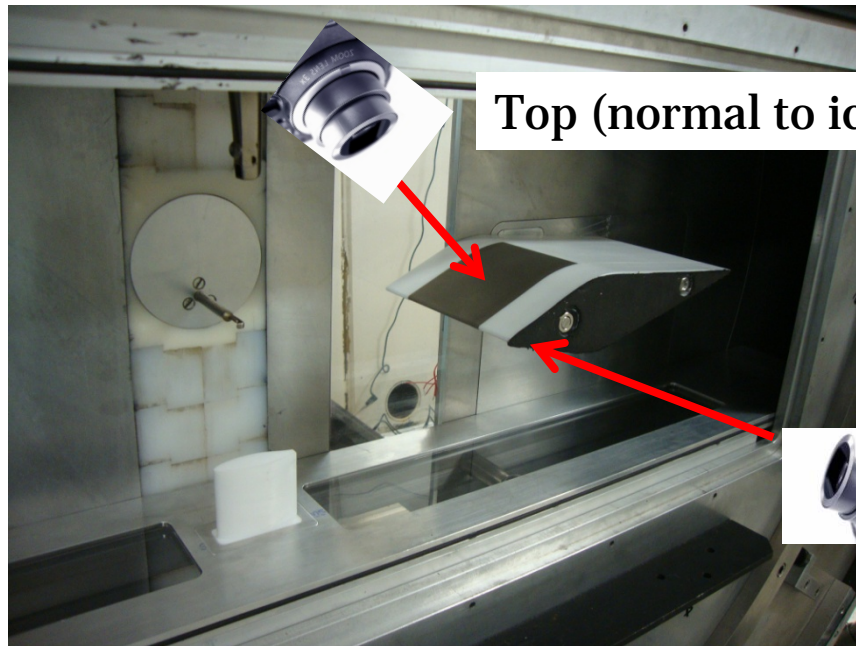

Top (normal to icing surface)



Side (end view of leading edge)

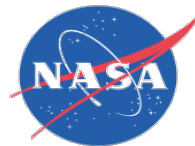

SAE *International*™

2011-38-0018

Fundamental Ice Crystal Physics Studies

Imaging Views



1. Side Backlit View



2. Front Perspective View

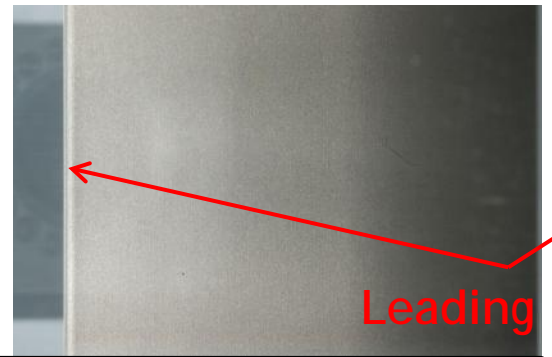

3. Top Views (still)

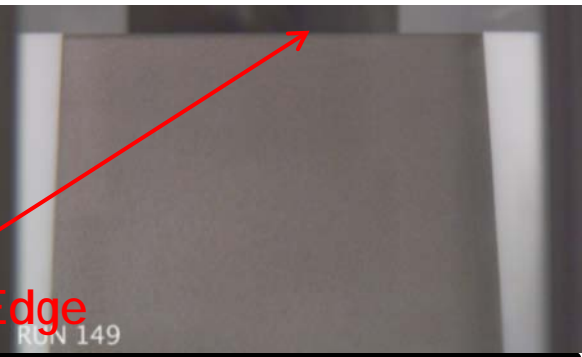

4. Top Views (HD video)

Leading Edge



Icing Test Procedure

- ▶ Tunnel operating conditions adjusted to obtain desired (dry air) test section p_o , TAT , M
- ▶ Multi-element probe used to determine spray water flow for supplemental LWC
- ▶ Steady-state data recorded under dry conditions
- ▶ Ice and water flows started. Ice mass flow for required IWC (g/m^3) determined from tunnel air volume flow.
- ▶ Data and video images recorded continuously during 3-10 minute test
- ▶ SEA probe inserted at end of test to measure IWC and LWC
- ▶ Airfoil deiced for next test

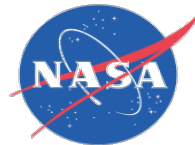

SAE *International*™

2011-38-0018

Fundamental Ice Crystal Physics Studies

Icing Test Results

- ▶ Most tests performed at 45 kPa or 93 kPa (6.5, 13.5psia), $M = 0.2$
- ▶ TAT typically $>6^{\circ}\text{C}$ higher at 45 kPa than at 93 kPa, but accretions generally much larger and better adhered at lower pressure

Test 121

93 kPa

$\tau_{\text{aero}} \leq 17\text{Pa}$

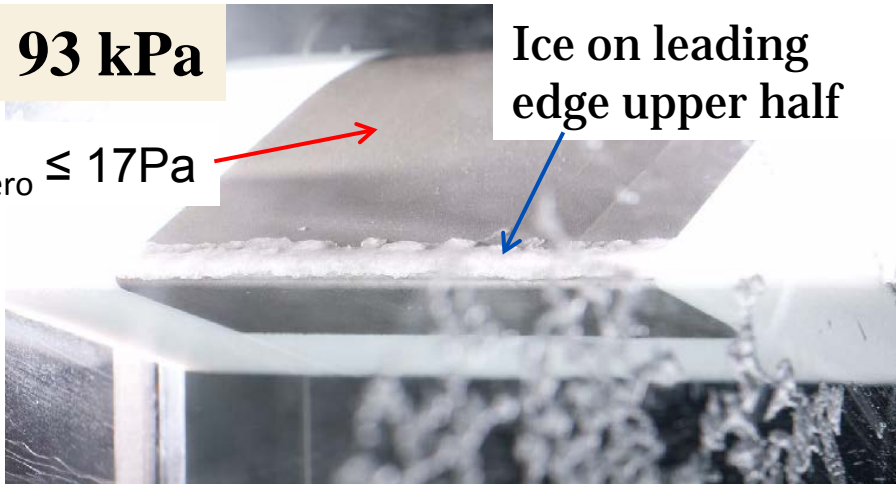

TAT= 6.2°C , LWC_i , $\text{IWC}_i = 0$, 20 g/m^3
 $\text{LWC}_m / \text{TWC}_m = 20\%$
(note: SEA underpredicts LWC, TWC)

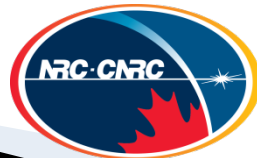

Test 149

45 kPa



TAT= 12.2°C , LWC_i , $\text{IWC}_i = 2$, 5 g/m^3
 $\text{LWC}_m / \text{TWC}_m = 42\%$

SAE International[™]

2011-38-0018

Fundamental Ice Crystal Physics Studies

Icing Test Results, cont'd

Why the Strong Dependence on Pressure?

- ▶ Believed to be due primarily to stronger evaporative cooling at lower pressure, characterized by wet bulb temperature TWB
- ▶ At TWB $\{= f(T, p, \text{moisture content } \omega)\}$

$$\mathbf{Q}_{\text{convection}} = \mathbf{Q}_{\text{evaporation}} \quad (\text{make-up water at TWB})$$

for wet adiabatic surface (closely approximated by hollow Ti blade)

- ▶ Evaporation also cools impinging water
- ▶ Melting of ice helps lower surface temperature to 0°C , but evaporation is required to lower to $0 - \varepsilon$, needed for strong adhesion
- ▶ TWB_0 based on T_0, p_0 is highest value on blade surface, so freezing possible everywhere when $\text{TWB}_0 < 0^{\circ}\text{C}$ depending on thermodynamics
- ▶ **TWB₀** typically **> 0°C** at **93 kPa** and **< 0°C** at **45 kPa** (TWB₀ = 3.7°C in test 121 at 93 kPa, -3.7°C in test 149 at 45 kPa)
- ▶ At TWB₀ < 0°C, impinging water froze on surface without added ice particles, similar to glaze ice.

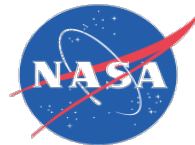

SAE *International*™

2011-38-0018

Fundamental Ice Crystal Physics Studies

Icing Test Results, cont'd

Accretions with Water Only, and Water+Ice Crystals, $TWB_o = -3.7^\circ\text{C}$

Test 151 \rightarrow 5 min @ $LWC_i = 2 \text{ g/m}^3$
(water only)

Test 151 \rightarrow 5 min @ $LWC_i = 2 \text{ g/m}^3$
+ 1.5min $IWC_i = 5 \text{ g/m}^3$



Adhered ice on
all Ti surfaces



Smoother ice

$TAT=13.4^\circ\text{C}$, 45 kPa $M=0.21$

- Effect of added ice greatest at leading edge

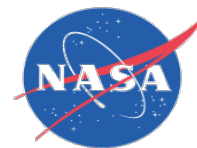

SAE International™

2011-38-0018

Fundamental Ice Crystal Physics Studies

Icing Test Results, cont'd

Effect of Added Ice Crystals on Leading Edge Growth Rate

Test 151 → 5 min @ $LWC_i = 2 \text{ g/m}^3$ (water only) – top view



~1/6" leading edge growth

Test 151 → 5 min @ $LWC_i = 2 \text{ g/m}^3 + 1 \text{ min } IWC_i = 5 \text{ g/m}^3$



>1/2" leading edge growth

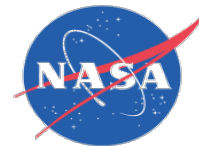

SAE *International*[™]

2011-38-0018

Fundamental Ice Crystal Physics Studies

Ice Thickness Measurement vs. Time - Test 151

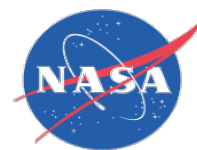
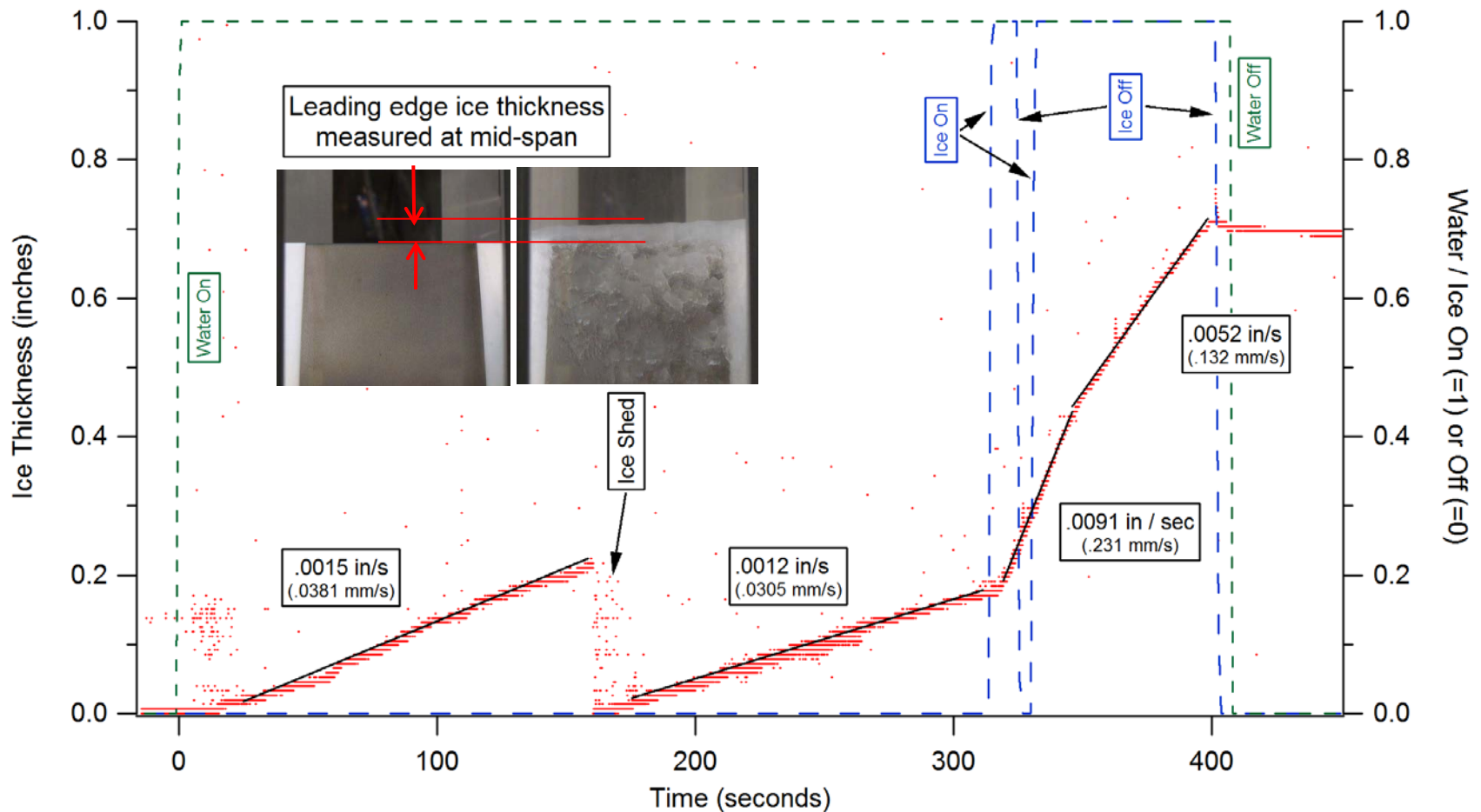

SAE International™

2011-38-0018

Fundamental Ice Crystal Physics Studies

Ice Thickness Measurement vs. Time - Test 149

TAT=12.2°C, , 45 kPa, $LWC_i = 2 \text{ g/m}^3$, $IWC_i = 5 \text{ g/m}^3$

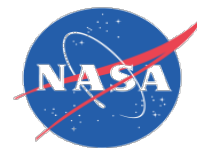
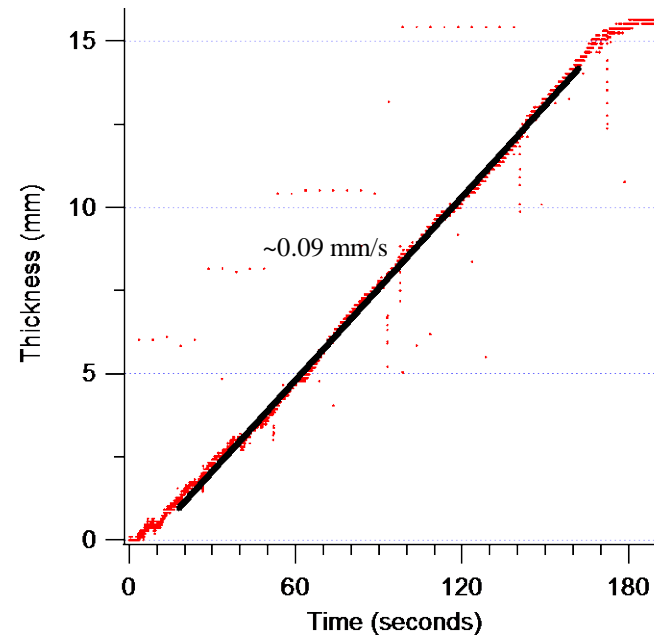
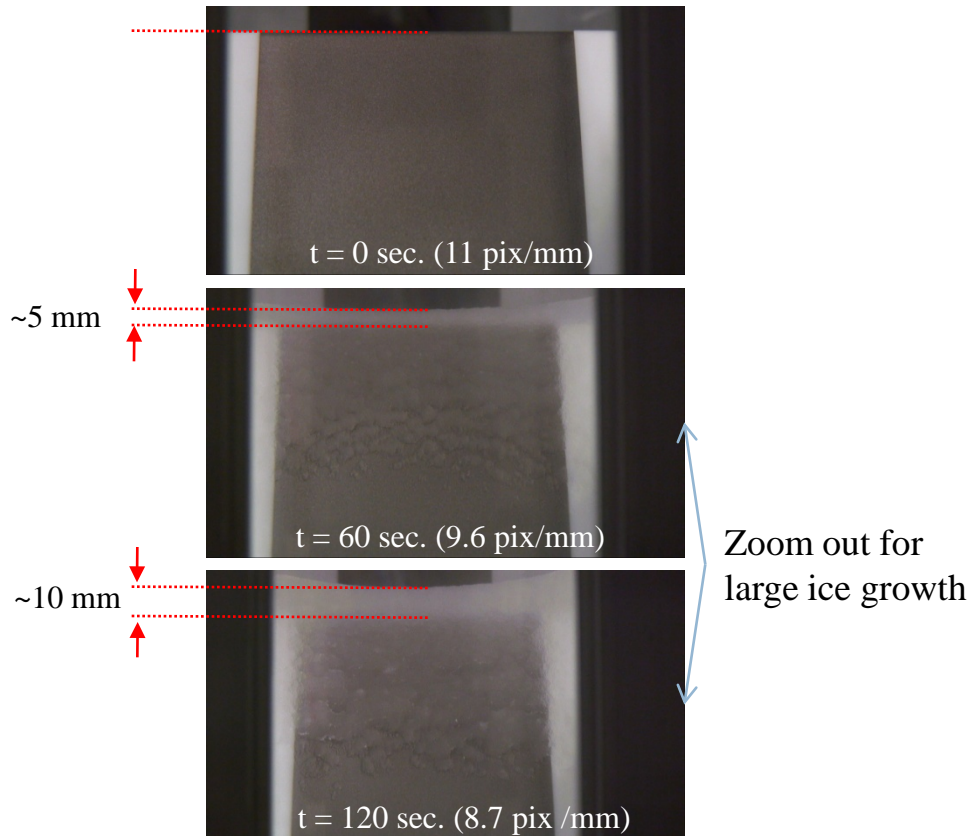

SAE International™

2011-38-0018

Fundamental Ice Crystal Physics Studies

Icing Test Results, cont'd

Additional Experimental Observations

- ▶ Significant natural melting of ice at 93kPa (LWC/TWC from SEA=20-32%) so supplemental water usually not added.
- ▶ Insignificant natural melting of ice at 45kPa (LWC/TWC from SEA=3-4%) so only very thin accretion layers observed without adding supplemental water
- ▶ Teflon remained ice-free except at the leading edge unless ice crystals added, when freestream particles and ice sliding along endwalls accumulated at blade/endwall junction
- ▶ Leading edge thermocouple $< 0.5^{\circ}\text{C}$ good indicator of whether ice would form

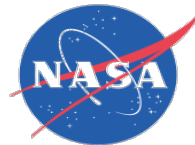

SAE *International*[™]

2011-38-0018

Fundamental Ice Crystal Physics Studies

Conclusions

- ▶ Results suggest strong evaporative cooling associated with $TWB < 0^{\circ}\text{C}$ provides mechanism for cooling surface exposed to impinging ice/water + melted ice/water below ice melting point, promoting freezing /high τ_{adh}
- ▶ Anchoring geometry (e.g. leading edge) generally required for significant accretion at $TWB > 0^{\circ}\text{C}$ because τ_{adh} is low
- ▶ Except near endwalls and/or at low M (τ_{aero}), serious accretions on stators/guide vanes only expected with $TWB < 0^{\circ}\text{C}$
- ▶ Additional experiments required to:
 - confirm the significance of evaporative cooling (humidity control now available in RATFac)
 - better understand the effects of pressure \rightarrow altitude scaling
 - explore the effect of Mach number variations on TWB_{local} (via effect on p_{static} , $T_{recovery}$) and ice adhesion, erosion, etc.
 - study geometries/conditions allowing significant deposits of non- or loosely-adhered ice at $TWB > 0^{\circ}\text{C}$

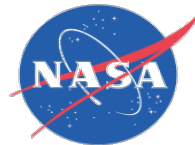

SAE *International*™

2011-38-0018

Fundamental Ice Crystal Physics Studies

Acknowledgments

- ▶ NRC authors would like to thank the FAA, Transport Canada, and NRC for their support and financial assistance
- ▶ NASA authors acknowledge support by the Atmospheric Environment Safety Technologies (AEST) project
- ▶ All authors would like to thank Tom Bond of the FAA for his guidance and support, and Chris Lynch for imaging support

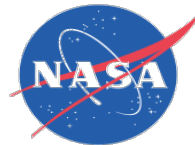

SAE *International*™

2011-38-0018

Fundamental Ice Crystal Physics Studies

Questions?

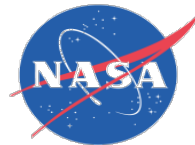

SAE *International*[™]

2011-38-0018

Fundamental Ice Crystal Physics Studies