



Feasibility of Large High-Powered Solar Electric Propulsion Vehicles: Issues and Solutions

*Lynn A. Capadona, Jeffrey M. Woytach, Thomas W. Kerlake, David H. Manzella, Robert J. Christie, Tyler A. Hickman, Robert J. Scheidegger, David J. Hoffman, and Mark D. Klem
Glenn Research Center, Cleveland, Ohio*

NASA STI Program . . . in Profile

Since its founding, NASA has been dedicated to the advancement of aeronautics and space science. The NASA Scientific and Technical Information (STI) program plays a key part in helping NASA maintain this important role.

The NASA STI Program operates under the auspices of the Agency Chief Information Officer. It collects, organizes, provides for archiving, and disseminates NASA's STI. The NASA STI program provides access to the NASA Aeronautics and Space Database and its public interface, the NASA Technical Reports Server, thus providing one of the largest collections of aeronautical and space science STI in the world. Results are published in both non-NASA channels and by NASA in the NASA STI Report Series, which includes the following report types:

- **TECHNICAL PUBLICATION.** Reports of completed research or a major significant phase of research that present the results of NASA programs and include extensive data or theoretical analysis. Includes compilations of significant scientific and technical data and information deemed to be of continuing reference value. NASA counterpart of peer-reviewed formal professional papers but has less stringent limitations on manuscript length and extent of graphic presentations.
- **TECHNICAL MEMORANDUM.** Scientific and technical findings that are preliminary or of specialized interest, e.g., quick release reports, working papers, and bibliographies that contain minimal annotation. Does not contain extensive analysis.
- **CONTRACTOR REPORT.** Scientific and technical findings by NASA-sponsored contractors and grantees.

- **CONFERENCE PUBLICATION.** Collected papers from scientific and technical conferences, symposia, seminars, or other meetings sponsored or cosponsored by NASA.
- **SPECIAL PUBLICATION.** Scientific, technical, or historical information from NASA programs, projects, and missions, often concerned with subjects having substantial public interest.
- **TECHNICAL TRANSLATION.** English-language translations of foreign scientific and technical material pertinent to NASA's mission.

Specialized services also include creating custom thesauri, building customized databases, organizing and publishing research results.

For more information about the NASA STI program, see the following:

- Access the NASA STI program home page at <http://www.sti.nasa.gov>
- E-mail your question via the Internet to help@sti.nasa.gov
- Fax your question to the NASA STI Help Desk at 443-757-5803
- Telephone the NASA STI Help Desk at 443-757-5802
- Write to:
NASA Center for AeroSpace Information (CASI)
7115 Standard Drive
Hanover, MD 21076-1320



Feasibility of Large High-Powered Solar Electric Propulsion Vehicles: Issues and Solutions

*Lynn A. Capadona, Jeffrey M. Woytach, Thomas W. Kerlake, David H. Manzella, Robert J. Christie, Tyler A. Hickman, Robert J. Scheidegger, David J. Hoffman, and Mark D. Klem
Glenn Research Center, Cleveland, Ohio*

Prepared for the
Space 2011 Conference and Exposition
sponsored by the American Institute of Aeronautics and Astronautics
Long Beach, California, September 27–29, 2011

National Aeronautics and
Space Administration

Glenn Research Center
Cleveland, Ohio 44135

Acknowledgments

The authors wish to recognize the entire SEP team at the Glenn Research Center for their dedication to this study. This paper would not have been possible without: Carl Blaser (CAD modeling), Bob Buehrle (Propulsion), Jose Cruz (S&MA), Tom Doehne (SE&I), Charles Doxley (Communications), Daryl Edwards (Propulsion), Rob Falck (Mission Design and Analysis), Kurt Hack (HEFT liason), Tyler Hickman (Reaction Control), Jeff Hojnicky (Power), Richard Kelsch (Structures), Tom Kerslake (Photovoltaics), Tom Kraft (Structures), Steve Mainger (Avionics), Dave Manzella (Propulsion), Mike Martini (Attitude Control), Kelly McEntire (Structures), Henry Nahra (MMOD), Mike Piszczor (Photovoltaics), John Ramsey (Structures), Carl Sandifer (Communications), Bob Scheidegger (PMAD), Paul Solano (Structures), Anita Tenteris (Risks), Lisa Van der Aar (Software), and Joanne Walton (SE&I).

This report contains preliminary findings,
subject to revision as analysis proceeds.

Trade names and trademarks are used in this report for identification
only. Their usage does not constitute an official endorsement,
either expressed or implied, by the National Aeronautics and
Space Administration.

Level of Review: This material has been technically reviewed by technical management.

Available from

NASA Center for Aerospace Information
7115 Standard Drive
Hanover, MD 21076-1320

National Technical Information Service
5301 Shawnee Road
Alexandria, VA 22312

Available electronically at <http://www.sti.nasa.gov>

Feasibility of Large High-Powered Solar Electric Propulsion Vehicles: Issues and Solutions

Lynn A. Capadona, Jeffrey M. Woytach, Thomas W. Kerslake, David H. Manzella, Robert J. Christie, Tyler A. Hickman, Robert J. Scheidegger, David J. Hoffman, and Mark D. Klem
National Aeronautics and Space Administration
Glenn Research Center
Cleveland, Ohio 44135

Abstract

Human exploration beyond low Earth orbit will require the use of enabling technologies that are efficient, affordable, and reliable. Solar electric propulsion (SEP) has been proposed by NASA's Human Exploration Framework Team as an option to achieve human exploration missions to near Earth objects (NEOs) because of its favorable mass efficiency as compared to traditional chemical systems. This paper describes the unique challenges and technology hurdles associated with developing a large high-power SEP vehicle. A subsystem level breakdown of factors contributing to the feasibility of SEP as a platform for future exploration missions to NEOs is presented including overall mission feasibility, trip time variables, propellant management issues, solar array power generation, array structure issues, and other areas that warrant investment in additional technology or engineering development.

1.0 Introduction

In the wake of the February 2010 cancellation of NASA's Constellation program, and in response to the FY2011 budget request, NASA was challenged to embark on a new human space exploration program. The Human Exploration Framework Team (HEFT) was formed and chartered to create an evolvable framework for efficient, sustainable human exploration of multiple destinations in the Solar System. Within the framework, the knowledge, capabilities and infrastructure that NASA would require to support a new exploration portfolio were examined, with a focus on demonstrating critical enabling technologies. Through a series of Design Reference Missions (DRMs), the HEFT team evaluated multiple scenarios to achieve a sustainable architecture, all of which stem from the basic premise to be flexible and evolvable over time and contain certain core elements. Solar electric propulsion (SEP) was quickly recognized as an element that may be able to capitalize on existing technology to accelerate vehicle development while reducing upfront costs and mitigating risk because of its many advantages: "gear ratio" (payload mass fraction) significantly higher than traditional chemical stages, greater mission flexibility of departure and return windows, less catastrophic failure modes over traditional chemical propulsion, potential for a reusable architecture, and finally, the substantial availability of power at the destination and during coast periods required for more ambitious exploration missions. SEP has the *potential* to cost effectively move payloads from low Earth orbit (LEO) to higher energy Earth orbits (geostationary Earth orbit (GEO), Earth-Moon L-1, Lunar, etc.). In order for SEP technology to be infused into NASA mission (human or cargo), the trip time has to be acceptable (generally in the range of 1 year or less) for the crew, and the payload must also occupy a significant mass fraction of the vehicle (at least equal to the wet mass of the vehicle itself). To realize the potential of SEP for large missions, several challenges unique to SEP technology must be understood and overcome to make this a sustainable exploration option: large scale solar array deployment, array pointing during spiral out of LEO, array stability during load events like large attitude control thruster firings and during docking operations, radiation belt array degradation, and plume impingement, to list a few.

NASA's Glenn Research Center (GRC) is uniquely positioned to examine these technological hurdles and understand how to overcome them with respect to mission feasibility. GRC has over 30 years experience in power and propulsion system development, and has demonstrated success on a number of

other SEP related vehicle activities over the years. As far back as 1997, a GRC team won an engineering award for the design of a Human Mars SEP tug driven by a total of 800 kW Hall-effect thruster (HET) power from LEO to a highly elliptical orbit (HEO) (Ref. 1). More recently, the Center has had involvement in multiple concept design demonstration proposals and studies. These include a Radiation and Technology Demo (RTD)—10 kW SEP tug powering a HET and Variable Specific Impulse Magnetoplasma Rocket (VASIMR) proposal in 2000 (Ref. 2), various 10 kW class interplanetary concept design studies (Refs. 3 and 4), and a lunar gateway Tug design (400 kW HET, LEO to E-M L1) in 2001 (Refs. 5 and 6). Last February, a SEP Technology Demonstration Mission (TDM) was proposed in the Office of Chief Technologist with a FY12/13 start. The objective of this project is to provide the maximum advancement of SEP technologies for the funds available as specified in the FY2013 Space Technology Program Resource Guidance (PRG). NASA Project Managers at GRC were directed to develop and implement the appropriate balance of technology maturation activities, including ground and/or flight elements, such that a SEP technology infusion point is possible in 2017 that supports the high powered (300 kW) capability needed for deep-space human exploration missions. By harnessing the resident expertise at the Center, a study team was formed that was able to generate a SEP vehicle concept to a level of detail sufficient to examine the factors that contribute to the development of a tug of this type and class, and the cadre of technology issues that should be addressed before development of a large, high-power SEP stage.

2.0 Overview

The concept developed by GRC was not intended to generate an optimized vehicle configuration. It's purpose was to examine the engineering and technology development challenges contributing to the development of a 300 kW class SEP freighter to support human exploration missions to NEOs, a DRM proposed by the HEFT. Development of such a class of vehicle would represent a new orbit transfer capability that does not presently exist. The concept was grounded in four figures of merit: mass, stowed payload volume, minimization of complexity (keep it simple), and use of single fault tolerance across the concept. The use of these FOMs ensured maintenance of concept validity for the study duration. Each vehicle system concept always began by employing existing technology to minimize the introduction of risk into the system, and help reduce programmatic cost to develop a vehicle of this class. This was particularly effective in refining most subsystems, however, the subsystems with the highest masses (power system solar arrays, as one example), did require use of low TRL materials to achieve acceptable solar array mass. Use of this “keep it simple” philosophy resulted in a system integration approach that focused on technology streamlining or mass reduction efforts in most areas. Figure 1 shows the relative breakout (by mass) of every subsystem of the concept vehicle generated by the Study Team. Systems with largest impact are obvious key areas to focus streamlining/reduction efforts. Notable mass trades in each subsystem area will be discussed in each respective section of this paper as well as any technology or engineering development areas of need that would help increase the technology readiness level (TRL) of that subsystem.

A broad systems engineering approach is imperative to the successful end-to-end design of such a concept vehicle. Treatment of an SEP tug as a collection of individually managed subsystem disciplines integrated at the end of the design process is not sufficient to understand the vehicle interdependencies as a whole, especially in the design phase. An integrated, iterative approach to vehicle development is critical. This paper will detail, subsystem by subsystem, the choices that were made and the technology challenges that were overcome. In almost all cases, design modifications within a subsystem were made in reaction to a change in another subsystem that produced a systematic impact. The following areas will be addressed: Mission Design and Analysis, Power/Propulsion, Environments, Structures and Mechanisms, Thermal, and Attitude Control.

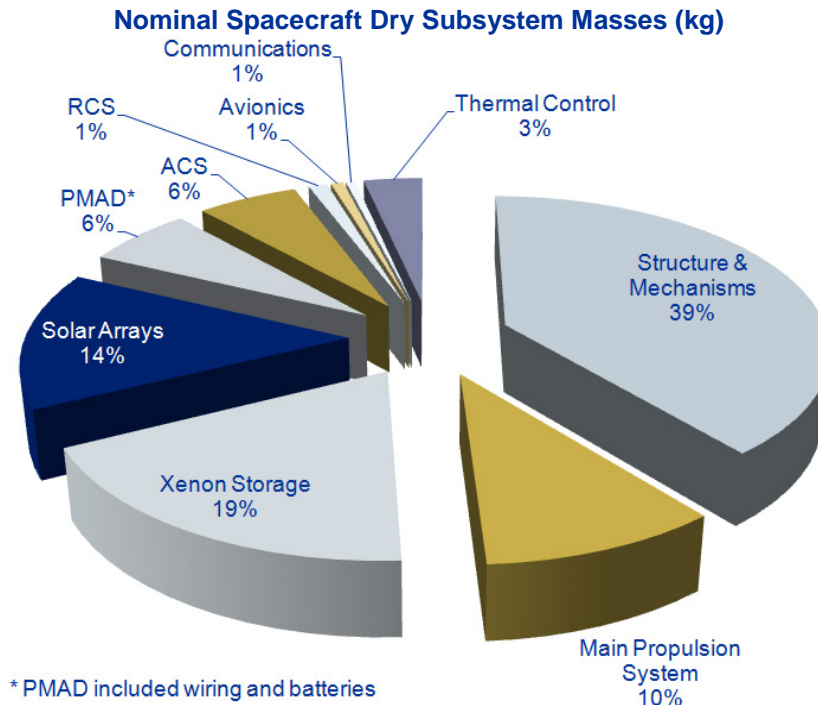

Figure 1.—Vehicle dry mass breakout by subsystem.

3.0 Subsystems Issues and Solutions

Certain ground rules and choices were made at the onset to establish a starting point for our Study Team. For example, the end-of life power goal was 300 kW at the input to the thrusters. A payload envelope was also assumed with a 7.5 m height and an 8.5 m diameter (based on a 10 m fairing). Our concept study limited trip time from LEO to EM-L1 to approximately 1 year. We also limited crewed mission duration from EM-L1 to the NEO and back to Earth at no greater than 400 days. Single fault tolerance was imposed across the vehicle in accordance with NASA’s requirements for human rating (Ref. 7) of space systems except in documented areas of exception such as pressure vessels and primary structure (as implemented in the Orion Crew Exploration Vehicle project). Certain other design choices were made because of existing knowledge with commercial off-the-shelf (COTS) products, or due to previous experience gained on International Space Station (ISS) or Constellation. The vehicle concept described in this paper is pictorially represented in Figure 2.

3.1 Mission Design and Analysis

The design of an SEP vehicle is a lesson in trades between the spacecraft’s power and electric propulsion (EP) systems and the manner in which the mission is to be flown. These three are intimately connected in an SEP vehicle; much more so than with a spacecraft utilizing a chemical propulsion system. Figure 3 illustrates the interplay involved in these system trades. The top-level mission requirements and ground rules mentioned above determined the type of EP system best suited for the mission. The long duration of the mission and, by extension, the higher throughput required of the thrusters were the key drivers. A Hall thruster system represents the most mature electric propulsion technology (Ref. 8) with characteristics desired for this mission, and the required propellant throughput and mission lifetime required for this EP system are achievable based on testing of smaller (~5 kW class) thrusters (Refs. 9 and 10). Since the spacecraft must spiral from LEO to the EM L1 point, Hall Effect thrusters were

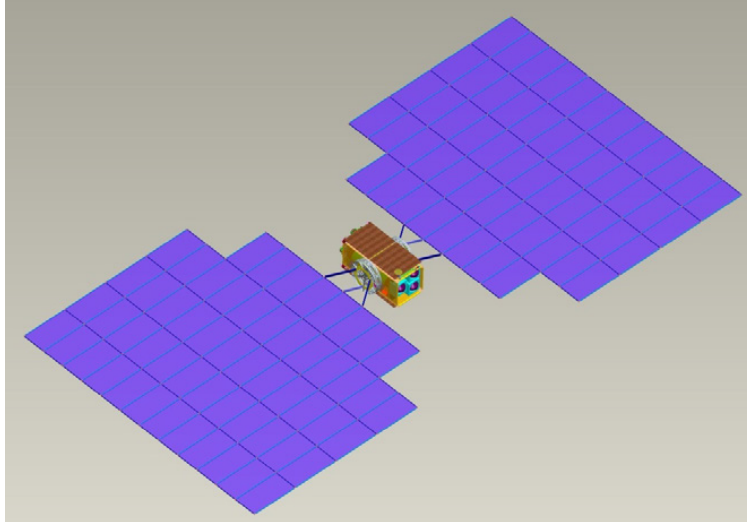

Figure 2.—GRC SEP vehicle concept showing main spacecraft body and notched solar arrays.

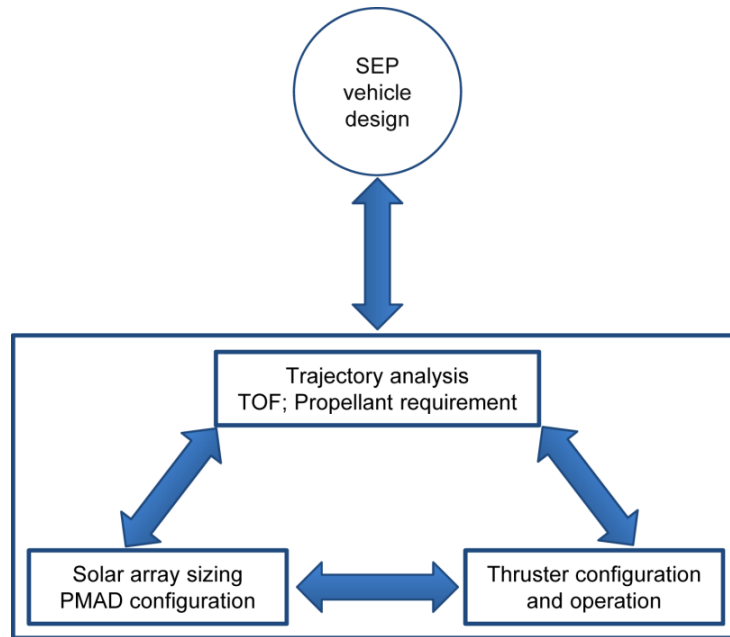

Figure 3.—Graphic showing the relationships involved in SEP vehicle mission design.

selected so that the higher thrust they provide would help minimize the time the spacecraft would spend in transit through the Van Allen belts. This minimizes degradation of the solar arrays that occurs when exposed to these charged particle environments, as well as the total radiation dose on the vehicle's electronics. A 30 kW per thruster power level was chosen for our study, with an operating current of 100 A because these power and current levels are the largest that have been previously demonstrated in laboratory thruster testing at GRC (Ref. 11). The operating current is determined by thruster mass flow rate. High flow rates require very high performance space simulation chambers for ground testing. A 100 A electric propulsion current relates to a propellant mass flow rate that is compatible with the space environment test facilities extant at GRC. This includes the capability to test a system of multiple thrusters in a vacuum environment while still maintaining vacuum quality (Ref. 12).

In a traditional EP system, a power processing unit (PPU) takes power from the spacecraft's Power Management and Distribution (PMAD) system and converts it to the voltages and currents that the thruster requires. All prior EP missions have utilized state-of-the-art (SOA) bus voltages; usually ≤ 100 V regulated (± 2 V typically) or 80 to 160 V unregulated. For any high power SEP vehicle, optimizing the solar array characteristics, PMAD, and EP characteristics as an integrated system will result in best vehicle performance. Since we were extremely time limited on our study, we proceeded without performing this optimization. For a flight mission, time and resources upfront would be invested to fully assess this. For our concept study it was decided to design a 300 kW SEP vehicle for 300 V—the voltage a SOA Hall thruster requires to provide 2000 sec of specific impulse.

PMAD and thrusters were chosen to operate directly from the solar array voltage (absence of PPU). This is referred to as direct drive (Refs. 13, 14, and 15). Direct drive minimizes the need for voltage conversion inside the PPU, thus decreasing mass and waste heat generation. Section 2.0 details the concept PMAD system. We refer to direct drive PPUs in our study as direct drive units (DDUs). Our analyses showed that DDU's are less than half the mass of conventional PPU's, and operate at 99 percent efficiency versus a PPU's 95 percent efficiency.

In our trajectory analysis, solar array degradation was modeled as a function of time during passage through the Van Allen belts. We investigated three methods of flying our concept vehicle from LEO to the EM-L1 libration point:

1. Constant voltage, where propellant flow rate is varied such that the array voltage remains constant during its degradation
2. Constant current, where propellant flow rate remains constant to maintain 100 A of current draw per thruster, until the array can no longer support the total current draw requirement due to degradation. After this point, a constant voltage is maintained.
3. Peak power, where the propellant flow rate is varied such that the current/voltage remains at the peak-power point of the array I/V curve throughout the spiral out.

The power and propulsion system and trajectory analysis interdependencies become even more intimate when the direct drive mode of operation of the EP system is baselined. For example, every time a trajectory was run with a different operating mode of the thrusters, the amount of main propellant changed. Sometimes this required resizing of the xenon tanks, which occasionally drove tank size growth to the point that the spacecraft bus structure also had to grow in order to accommodate the larger tanks. Since these changes increased the spacecraft dry mass, the trajectory analysis was repeated to re-optimize the trajectory, which would then impact the amount of main propellant, which caused us to revisit tank size, etc. Again, the time frame available to complete the study did not allow vehicle performance optimization for this mission. In the end, a constant current mode of operation for the thrusters which minimized initial mass in low Earth orbit (IMLEO) was chosen for the very limited trade space we were able to cover. This was not intended to be a true end-to-end mission optimization.

The mission was modeled using a combination of trajectory analysis tools and techniques. The Earth spiral to L1 was modeled as a tangential thrust spiral trajectory to a semi-major axis of 150,000 km. The vehicle attitude control was modeled to be capable of rolling to an attitude such that the arrays directly face the Sun (when not in Earth's shadow). The GRC SNAP trajectory propagation tool (Ref. 16) was used for the Earth spiral to EM L1, and JPL's MALTO software (Ref. 17) was used for the heliocentric portion of the mission. For pre-Phase A and Phase A analyses, using these tools in this manner is reasonable, but performing trajectory analysis for a flight mission will require a much higher fidelity level of simulation. For mission analyses utilizing large SEP vehicles (particularly for human missions), a single, high-fidelity 6-DOF tool is required using a combination of analytic steering laws for the spiral out combined with polynomial fits for the heliocentric phase. The Mission Design and Analysis Branch and Power Systems Engineering Branch in the Systems Engineering and Analysis Division at GRC are engaged in developing a high-fidelity mission analysis suite for large SEP vehicles, combining the required trajectory analysis fidelity with a detailed solar array performance model along with optimization

of other mission parameters (i.e., time spent in transit of the Van Allen belts, crewed and non-crewed trip times, thruster performance limitations and degradation, solar array performance limitations and degradation, PMAD operating schemes, etc.

3.2 Power and Propulsion

3.2.1 Solar Array Sizing and Loading

The SEP vehicle solar array shown in Figure 4 was sized to provide 300 kW and 300 Vdc at the electric propulsion interface at the end-of-life (EOL). For comparison, the eight solar array wings on the International Space Station could produce a combined power output of approximately 250 kW at 160 Vdc at beginning-of-life (BOL) but have a mass approximately five times higher than that of the SEP vehicle solar array. Accounting for SEP vehicle solar array integration loss factors (such as harnessing voltage drop), operational loss factors (such as sun pointing error and solar cell operating temperature) and natural and induced environmental degradation factors (discussed in Section 3.0), the resulting solar array was size was 594 strings of 134 series connected inverted metamorphic, 34 percent efficient solar cells.

These solar cells populated flexible blankets with a 1300 m² total area divided amongst 56, 2.5- by 5.0-m bays comprising each of the two solar array wings approximately 25 m on a side, modeled after ATK Aerospace System's "SquareRigger (Ref. 18)" concept. Each solar array wing has a mass of approximately 1300 kg including at 30 percent mass growth allowance.

The corner bays along the inner edge of the two solar array wings were removed to avoid excessive electric propulsion thruster plume impingement effects (sputtering erosion and contamination). One of the chief solar array production challenges is the required surge in high efficiency space solar cell production to allow for fabrication of these very large solar array wings on each of two SEP vehicles to be launched within the period of a year. This surge in space solar cell production would require a significant increase in the annual output of U.S. manufacturers over the planned period of flight solar cell production.

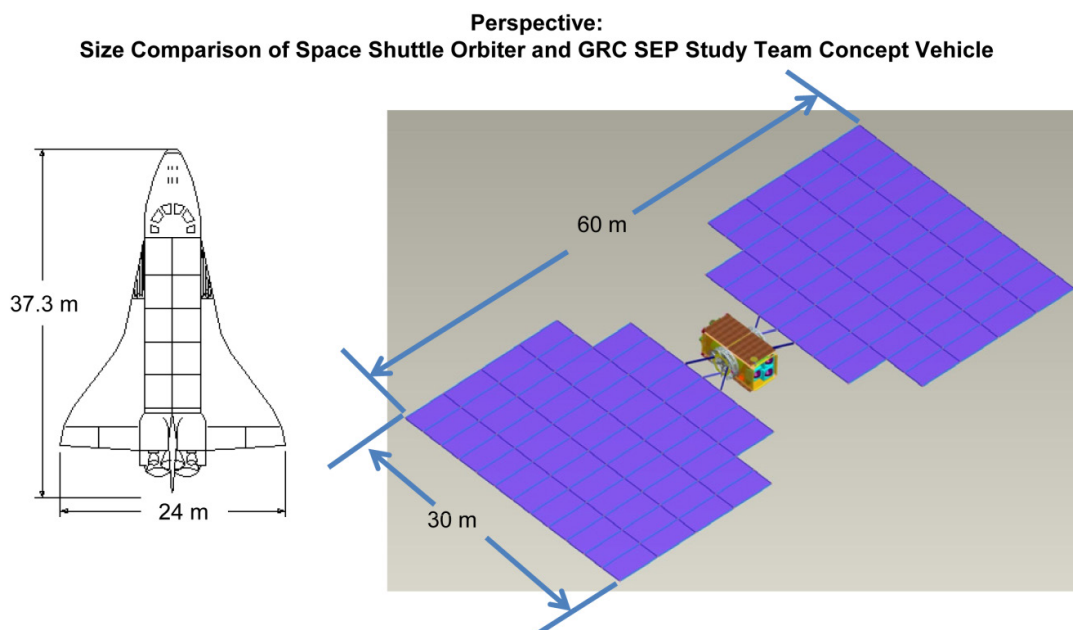

Figure 4.—Relative sizes of SEP concept notched solar arrays relative to Space Shuttle dimensions.

The SquareRigger bay composite structure and yoke were sized to handle the required deployed g-loading and also to maximize deployed frequency. Deployed g-loads were assessed for external, high load events such as a high thrust propulsion stage main engine cut-off. This event in particular was found to drive deployed g-load based on preliminary assessments. Other loading events evaluated were docking loads and docked vehicle attitude control thruster plume impingement loads during proximity operations. The driving solar array wing deployed g-load was 0.2-g based on the in-space stack thrust-to-weight ratio of 0.1-g times a dynamic amplification factor of 2.0 based on the assumption of a step fall-off in high thrust main engine cut-off. Stowed wing launch restraint and release hardware and secondary structures were sized to meeting ascent loading conditions (see Section 4.0).

3.2.2 Power Management and Distribution

Power management and distribution supporting a spacecraft with a propulsion system that consumes 90 percent of the total power generated created unique issues for power system stability and controllability. Furthermore the use of direct drive introduces a direct connection between the solar array and the propulsion system that highlights potential power system stability and power quality issues.

The power distribution system was broken up into a high voltage main bus and a low voltage secondary bus as seen in Figure 5. The main power bus provides primary power to the propulsion system and primary power to the secondary dc-dc down converters. The main power distribution architecture was optimized by evaluating multiple distribution configurations. The low voltage secondary bus is supported by batteries that provide power to avionics and internal housekeeping loads during eclipse. The power source for the secondary bus was evaluated between main bus derived or segmented array derived power. Main bus power was selected, which down converts a secondary voltage optimizing the use of all solar array power for any subsystem requiring the unused power. The secondary bus is isolated from the main bus by a dc-to-dc power converter. The secondary bus batteries provide power to the spacecraft loads and propulsion heaters during eclipse. The SEP also carries requirements to provide payload power which can be provided directly from the main bus or by the secondary bus.

Controllability of the bus voltage and overall power quality are impacted by the source-load characteristics for the array and the primary load (propulsion system). The manner in how the system is started, how much noise is generated by the system, and dealing with electrical faults must be accounted for in the power system design. Bus voltage control was evaluated via two approaches; a) control the vehicle bus voltage by the propulsion system, or b) introduce a dedicated bus regulator. Option a) was abandoned due to the long coast periods when the propulsion system is not active. During coast, the solar

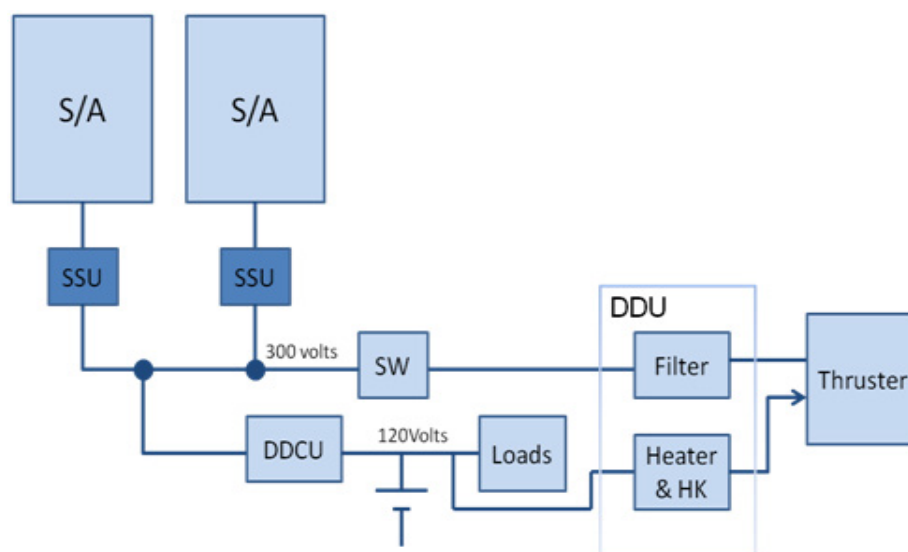

Figure 5.—Bus structure details.

array is very lightly loaded and bus voltages will approach array open circuit voltages, in addition the main bus voltage will experience very high voltages from the solar arrays when transitioning from eclipse. For these reasons a regulated bus approach was adopted. Two types of regulation approaches were evaluated, one using a peak power tracking (PPT) series regulator and a shunt regulator or sequential shunt unit (SSU). The PPT counteracts the advantages of direct drive. The SSU provided regulation without the disadvantages of the PPT. In addition the SSU can take advantage of full array power at BOL to the propulsion system by allowing for adjustments in main bus voltage for elevated BOL levels. An additional benefit of the SSU can be to provide short circuit protection of array strings that may experience high voltage plasma arcing.

Early experimental hall thruster data indicates the thruster produces substantial current oscillations during operation. To control the current fluctuations produced by the thrusters, an input filter is required to limit inrush currents and decouple the ripple current that each thruster contributes. The input filter would be comprised of passive devices to isolate the ripple currents from the main bus. The input filter is housed with the other housekeeping power supplies required to operate the thruster in a DDU.

Stability of this power system is achieved both through design and operation. Design of the SSU will provide power system stability and avoid voltage swings as power levels change throughout the mission. In addition, providing proper input power filtering will isolate the main power bus from voltage variations produced by thruster interactions with the main bus. Thruster operating procedures will be required so that current surges during start-up do not interfere with the operation of the power system, and so that current inrushes to the thrusters do not result in collapsing the arrays. Generally, stability can be achieved by operating the propulsion system below the knee of the solar array I-V curve. On the positive side the thruster is very tolerant to moderate voltage swings with small effects to the propulsion system performance, therefore perturbations of the propulsion system do not directly couple back into the power system. There are still other unknown issues that include thruster plasma interactions due to the multi-thruster configuration and current sharing with respect to the thruster cathodes for multi-thruster configurations. In addition, for the case of direct drive, due to the direct connection of the propulsion system to the solar array, momentary high current events can introduce instability in the power system that must be further assessed.

System grounding methods were also briefly investigated; both positive and negative grounding was briefly evaluated. System grounding refers to how the spacecraft is connected to the solar array and how it is impacted by the charged plasma surrounding the spacecraft. Both alternatives have advantages and disadvantages that this concept vehicle did not fully address

3.2.3 Addressing Insolation Periods

Spiraling out from LEO to the EM-L1 libration point means that the vehicle is flying in and out of eclipse. To maintain a sensible battery mass, thruster operation is precluded during eclipse. However, the thruster should be kept in a “ready state” to begin firing as soon as possible once the vehicle moves into the sunlight portion of the orbit. To accomplish this, our concept study adopted an operational scenario where we utilized the vehicle’s sun sensors and array power to register when the vehicle entered the penumbra of Earth’s shadow. At this time, the vehicle’s flight computer would begin to ramp thruster power down from nominal to zero over short period of time. Shut down is achieved by removing propellant flow as opposed to removing power from the thrusters. The ramp down was accomplished by shutting off xenon flow (time constant determined by volume between xenon flow control valves and the thrusters). Cathode flow was maintained (5 to 10 percent of total nominal propellant flow) during eclipse to allow continued cathode operation. This flow rates provides essentially zero thrust. The keeper power supply was maintained to sustain cathode operation when current dropped below 30 percent of nominal. When discharge current reached zero, magnet power supplies were deactivated. During eclipse the thruster cathodes run at 200 W (10 A and 20 V), anode flow rate zero, magnet power zero.

When flying out of eclipse, magnet power and anode flow are reinitiated. Discharge will reignite at open circuit voltage once flow rate rises above zero. The initial current level should be low as flow rate

ramps up. Current and power will ramp up to nominal as flow rate reaches nominal value. Keeper supply is turned off after current reaches more than 30 percent of nominal value.

3.3 Environments

When considering aggressive missions beyond LEO, the natural and induced environments the vehicle needs to withstand must be well understood. Three main environmental issues were examined: induced impacts of the EP plume on the vehicle solar arrays, environments during spiral out of Earth orbit (Van Allen belt trapped proton and electron radiation), and the micrometeoroid and orbital debris (MMOD) environment and shielding.

The EP plume can completely erode the solar cell optical coatings on the arrays resulting in power losses and could completely erode thin flexible solar array blankets leading to structural failure. With careful, deliberate design choices, the solar array design performance loss in this case was limited to ~5 percent by positioning solar array surfaces away from the EP plume at the expense of greater solar array structure mass.

One other option considered to mitigate this environmental issue was to house the thrusters and gimbals on a platform at the end of a deployable boom to physically distance the plume from the solar array to mitigate the degradation risk. This adds complexity and mass to the system, requiring propellant lines, high power cables and command and data lines to be flexible in nature and deployed along with the boom. The study team's power system and main propulsion leads worked together to perform a study of array degradation due to thruster plume effects and concluded we could eliminate the boom and "notch" the arrays to avoid direct plume impingement. Their study also showed that plume impingement would occur to some degree whether or not a boom was used. Though the greatest degree of plume contamination was bounded within a 45° half-cone angle centered on the thruster, the plume wraps back around itself, 360°. By notching the arrays we eliminate the greatest effects and then design the arrays to accommodate secondary and tertiary plume effects (see Figure 2).

With respect to radiation environments, travel through the Van Allen belts was a significant concern on spiral out. The most obvious impact is degradation to the solar array solar cells from trapped electrons and protons during the slow transit through these belts. Of particular concern, are high energy (10 MeV and above) trapped protons encountered at orbital altitudes of approximately 2,000 to 15,000 km. These high energy trapped protons produce the bulk (>95 percent) of solar cell damage compared to trapped electrons and solar flare protons. The traditional approach to handling solar cell radiation damage performance loss is to shield the cell with cover glass to limit the equivalent 1-MeV electron dose to approximately $1 \times 10^{15}/\text{cm}^2$ and then over-size the solar array current and voltage capability. This approach was adopted, utilizing the minimum amount of glass shielding of 5-mils thickness on the front and back sides (to restrict solar array areal mass increase) and resulting in approximately 20 percent solar array power loss at EOL for the envisioned mission.

Vehicle MMOD protection was also a challenging problem to solve since the traditional MMOD risk assessment code BUMPERII (Ref. 19) is designed for LEO (~2000 km). The MMOD shielding on the vehicle was sized based on the "no damage allowed to the propellant tank" criterion, which has Constellation Program heritage for the LEO portion. Orbital debris was factored in over a very brief period of time because the vehicle spends limited time in such an orbit. The micrometeoroid portion was assumed to be the major contributor to vehicle damage over the life of the mission. Micrometeoroid flux penetration was calculated with respect to SEP distance from Earth by extrapolation of the Grun model (Ref. 20) used in the ISS version of the BUMPER code models. To account for the flux behavior with altitude, the Earth gravitational focusing and shielding factors were calculated as well. The Earth gravitational focusing factor accounts for the increased flux due to the Earth gravitational field. This factor decreases with altitude. The Earth shadowing or shielding factor accounts for the fact that Earth shields from impacting micrometeoroids. This shielding factor varies with altitude as the SEP spirals away from Earth LEO. The flux of penetrating particles is calculated based on a critical particle diameter that penetrates the designed shielding which is determined from a ballistic limit equation (Ref. 21).

Particles of diameter greater than the critical diameter present a risk to the SEP. The probability of no penetration was then calculated from the penetrating flux using Poisson statistics (Ref. 19). The model results were applied to the outer closeout panel structural composite skin on both the solar array gimbal sides of the vehicle as well as the top closeout panel. No additional shielding was needed on the radiator sides of the vehicle.

3.4 Structures and Mechanisms

The primary drivers in designing the spacecraft structure for the concept vehicle were launch loads. The effect of launch loads was magnified since we assumed a launch configuration that not only included the SEP vehicle, but also included two other elements mounted on top of the SEP vehicle, the crew habitat module and the multi-mission space exploration vehicle. Buckling loads were the key driver of the strength of the spacecraft structure, and hence the structure's mass. The concept structure began as aluminum thrust tube and morphed through several iterations into an aluminum-lithium structure with aluminum honeycomb outer panels with composite face sheets.

The solar array single axis gimbals were based on the only analogous gimbal mechanism with flight heritage—the ISS Solar Alpha Rotary Joint (SARJ). Utilizing two SARJ mechanisms along with a growth contingency resulted in a total mass for both gimbals of nearly 2,700 kg. Again, time limitations on the study did not permit optimization of this mass. The SARJ is designed with a high level of redundancy for its 15 year service life at 100 percent duty cycle of 360° rotations. An engineering development program based on SEP vehicle mission requirements and incorporating a sizeable mass reduction effort should be initiated for development of solar array gimbals for an SEP tug.

3.5 Thermal

The thermal subsystem may be one of the cleanest examples of interdependence with a SEP vehicle using Direct Drive. Thermal control went through several re-designs as work progressed. One of the positive impacts of going to the direct drive architecture was that waste heat was dramatically reduced. Direct drive forgoes the use of PPUs for the thrusters. As a result, as the power system architecture matured we were able to go from a deployed set of thermal radiators to a relatively simple configuration of body mounted radiators. The design challenges are described here.

For the initial configuration of the SEP, it was assumed that the thermal conditioning system would be similar to the system used for the ISS Photovoltaic Module. GRC managed the development and testing of this system, which consists of a pumped ammonia system with deployable radiators. A similar system is also used for the ISS Environmental Control and Life Support System (ECLSS). Due to the numerous distributed heat sources with large high power densities and high dissipation rates and the requirement that the system operate in LEO and NEO environments, it was more practical to use a pumped fluid for cooling rather than other heat removal methods, such as heat pipes.

The initial design required a constant heat rejection capability of 17.4 kW. The main source of this heat was the Array Regulator which was assumed to have an efficiency of 95 percent because it incorporated a voltage converter. In order to continuously reject 17.4 kW the radiators needed to have a total radiative area of 232 m². Therefore two two-sided radiators with dimensions of 5- by 12-m were selected. Because of this large size the radiators had to be deployable, similar to the ISS Photovoltaic module.

As the vehicle design matured, additional heat sources were identified but the Array Regulator efficiency was increased to 99 percent. This increase in efficiency was enabled by incorporating 'direct drive', i.e. the thrusters would be operated at the same voltage as the solar array output and no voltage conversion was required. This reduced the total heat rejection to 10.8 kW and the required area to 55 m². Since the radiator size was now 3.5- by 8-m, it was deemed feasible to mount the radiators on the boom that supported the thrusters. Although the radiators were still deployable, they were now partially supported by the thruster boom structure and their structural mass could be reduced.

In a final design refinement, the heat decreased slightly to 9.56 kW and the required radiative area decreased to 44 m². The larger reduction in radiator area was achieved by increasing the coolant temperature by 30 °C and changing the fluid type to HFE 7000. Because the radiator now radiated at a higher temperature, the radiative area could be significantly reduced. The dimensions of the vehicle body also increased and it was found that one-sided body-mounted radiators could be used on two sides of the vehicle, and deployable radiators were not necessary. The radiator panel design was changed to be similar to the radiator panels being developed for the Orion Service Module which GRC is providing technical insight and oversight for. At the end of the final design iteration, the total mass of the thermal control system was reduced to 28 percent of the initial estimate. This reduction was mainly accomplished by incorporating a direct drive power management system and increasing the coolant fluid temperature. Table I provides a summary of the progression of the thermal system design values through the study iterations.

TABLE I.—CHRONOLOGICAL DEVELOPMENT OF THERMAL SUBSYSTEM DESIGN VALUES DEMONSTRATING THE 28 PERCENT REDUCTION IN SYSTEM MASS

Iteration	Required heat rejection rate, kW	Radiating area, m ²	Thermal system mass, kg
0	17.4	232	2,050
1	10.8	110	1,240
2	9.56	44	586

3.6 Attitude Determination and Control

The AD&C subsystem for the concept vehicle consists of star trackers, horizon sensors, sun sensors, control moment gyros (CMGs), an inertial measurement unit (IMU), and a bi-propellant propulsion system. The subsystem is single fault tolerant and all components are off-the shelf with a high technology readiness level. A block diagram is shown in Figure 6. During the spiral out of LEO a roll steering is used twice per orbit to maintain pointing of the solar arrays. This maneuver requires three CMGs to provide momentum storage capability about all three axes (including redundancy) and a propulsion system for wheel de-saturation. It was assumed that 20° of array off-pointing is acceptable and two of the SEP thrusters can be gimballed up to 15° to offset some of the disturbance torques. The CMG specifications are based on what is currently flying on the International Space Station. Each one has a mass of 272 kg, stores 4760 Nms of momentum, and has a maximum output torque of 258 Nm. More analysis is required, but it is possible that the use of roll steering could be eliminated. This would result in a significant mass savings because the CMGs could be eliminated but the trip time would increase due to the cosine loss on the arrays. Clearly, if CMGs are to be utilized on an SEP tug, an engineering development program should be initiated to create a significantly lower mass CMG than that developed for the ISS while still maintaining a comparable momentum storage capacity.

The worst case total propellant load required to desaturate the CMGs in every axis was determined to be 367 kg. Monomethylhydrazine (MMH) and nitrogen tetroxide (NTO) were selected for the bi-prop reaction control system because of the higher specific impulse they offer over a blowdown hydrazine system and because of recent experience and developments on the Orion Service Module Propulsion System. Four pods of six R1E engines (25 lbf thrust each) were set as the baseline. The thruster size and locations are notional and require further analysis. If the CMGs get eliminated or the total propellant load decreases, the propellants and engine selection would likely be re-evaluated to find the most mass efficient design solution.

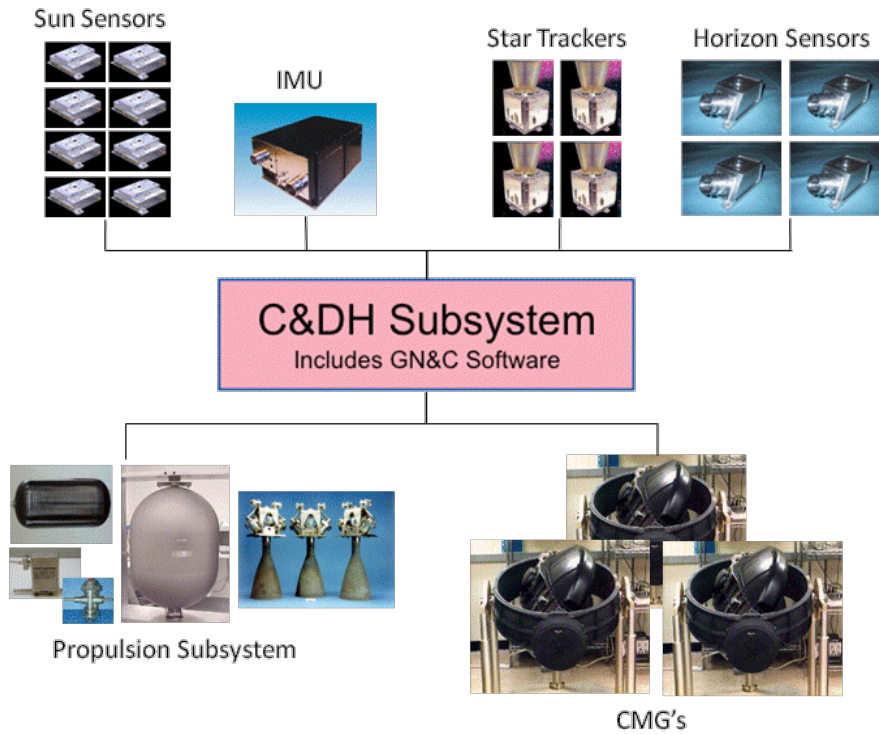

Figure 6.—AD&C block diagram.

4.0 Feasibility

The overall challenge to implement an SEP vehicle into an exploration architecture for NASA without question hinges on affordability. Investment in technology and engineering development of key components is imperative before a large SEP vehicle can be developed. The risk and cost reduction provided by these developments will enable development of the SEP vehicle. Without them, mass and cost will continue to be a challenge, especially given launch vehicle payload envelope and up-mass restrictions.

As illustrated by this paper, development of light weight solar array support structures will be critical. Though these structures must be low in mass, they must be of high strength and stiffness to support the large area arrays during docking and other loading events. Keeping the solar arrays to a manageable size will also keep impacts to the vehicle's attitude determination and control system to the minimum necessary for mission success. In addition to this, solar cell and blanket technology must mature sufficiently to provide the high output efficiency required to keep the large arrays at a manageable size for launch vehicle stowage. To design an SEP vehicle today, solar cell production capability would need to increase as currently available off-the-shelf photovoltaic cell providers have an estimated annual production rate on the order of ~ 300 kW and a SOA 29 percent efficiency. Although it would be possible to create a vehicle using existing technology, development activities especially in the photovoltaics area could certainly enhance efficiency over the current SOA, and mass in turn.

In addition to low mass, high strength solar arrays, the gimbal mechanisms that will drive these arrays must also be low mass yet robust enough to meet mission requirements. The SOA gimbal for large solar arrays (the ISS SARJ) must be significantly reduced in mass, yet be able to pass substantially higher voltage and current than the ISS SARJ.

Externally, several factors also impact the ability to cost-effectively produce and operate a vehicle of this type. A large SEP vehicle will require a xenon propellant mass nearing 30,000 kg. Xenon is a trace element found in the Earth's crust, sea water, and most prevalently the atmosphere at a density on the order of 100 parts per billion. It is estimated that there is more than 10^{12} kg of naturally occurring xenon

worldwide (Ref. 22). As a result, the 30,000 kg required for this application is a very, very small amount with respect to the total amount available. However, this amount of xenon is in excess of 50 percent of current total annual worldwide production (Ref. 23), resulting in a significant acquisition challenge. Xenon is produced as a by-product from air separation process, most commonly associated with the steel industry and is used in a number of applications other than electric propulsion including the lighting industry and various medical applications. While production capability beyond that needed to meet current worldwide annual usage currently exists, an acquisition strategy would need to be developed to purchase the required amount of xenon without having a dramatic impact on the world xenon market (Ref. 24). Such strategies include stockpiling over the course of several years and entering into long term contractor with suppliers.

Propellant management on the vehicle presents some engineering development challenges, as well. Large composite overwrapped pressure vessels (COPV) will be required to store the xenon for the SEP mission. These tanks are larger COPV tanks than have ever been manufactured before. Though they must be kept relatively light weight, these tanks must also demonstrate their pressure integrity in addition to their ability to provide protection against M/MOD impacts that could occur during the spiral out from LEO. Manufacturing large COPV tanks of this size represents an engineering development challenge that must be answered.

To maintain solar array pointing during the spiral out from LEO, the SEP vehicle's attitude control system will need momentum wheels of low mass but high momentum storage capacity. Again, the SOA momentum wheels for a large vehicle (the ISS CMGs) must undergo an engineering development program to decrease their mass while maintaining or increasing their momentum storage capacity.

Mission design and trajectory optimization of a SEP mission will require a suite of tools to manage the interplay between trajectory and vehicle impacts. With variables like IMLEO, trip time, solar array degradation from passage through the Van Allen belts, all vying for importance, an integrated suite of analysis tools is needed for this SEP mission to insure that all variables are addressed so that the mission can meet all of its requirements.

Lastly, cluster Hall thruster operation, particularly in the direct drive mode of operation, need to be demonstrated in the space environment of the outward LEO spiral in order to increase the the TRL level of the thrusters and the DDU's for future application to the 300 kW class vehicle. This technology maturation will also validate the integrated software suite for mission design.

5.0 Conclusion

A point concept SEP vehicle was created by GRC with significant analysis completed. Through concurrent systems engineering, we have demonstrated a workable solution for an SEP vehicle independent of many outside constraints. More importantly, we have a sound understanding of the issues and challenges presented to us as the design matured, and intimate knowledge of the interdependent nature of SEP vehicle development. The resident expertise at GRC makes the Center extremely well positioned to understand and overcome the challenges involved with SEP system design. Appropriate investment in technology development is critical toward development of a reusable SEP system that can cost effectively transport NASA assets to and from more aggressive mission destinations.

References

1. Dudzinski, Leonard A., Hack, Kurt J., Gefert, Leon P. and Kerslake, Thomas W., "Design of a Solar Electric Propulsion Transfer Vehicle for a Non-Nuclear Human Mars Exploration Architecture," 26th International Electric Propulsion Conference, paper IEPC-99-181, Kitakyushu, Japan, Oct. 17-21, 1999.
2. Kerslake, Thomas W., Haraburda, Francis M. and Riehl, John P., "Solar Power System Options for the Radiation and Technology Demonstration Spacecraft," 35th Intersociety Energy Conversion

- Engineering Conference, AIAA-2000-2807, Las Vegas, Nevada, July 24-28, 2000. (See also NASA/TM—2000-210243.)
3. Kerslake, Thomas W., and Gefert, Leon P., “Solar Power System Analyses for Electric Propulsion Missions,” 34th Intersociety Energy Conversion Engineering Conference, SAE 99-01-2449, Vancouver, British Columbia, Canada, August 1-5, 1999. (See also NASA/TM—1999-209289.)
 4. Kerslake, Thomas W., “Solar Electric Propulsion Mission Architectures,” Space Power Workshop, The Aerospace Corporation, Redondo Beach, CA, April 21-24, 2003. (See also NASA/TM—2003-212456.)
 5. Sarver-Verhey, Timothy R., Dudzinski, Leonard J., Kerslake, Thomas W., Oleson, Steven R., and Hoffman, David J., “Solar Electric Propulsion Vehicle Design Study for Cargo Transfer to Earth-Moon L1,” 5th SAE Power Systems Conference, Society of Automotive Engineers, Coral Springs, FL, October 29-31, 2002. (See also NASA/TM—2002-211970.)
 6. Sarver-Verhey, T. R., Kerslake, T. W., Rawlin, V. K., Falck, R. D., Dudzinski, L. J. and Oleson, S.R., “Solar Electric Propulsion Vehicle Design Study for Cargo Transfer to Earth-Moon L1,” paper AIAA-2002-3971, 38th AIAA/ASME/SAE/ASEE Joint Propulsion Conference & Exhibit, Indianapolis, IN, July 7-10, 2002.
 7. Human Rating Requirements for Space Systems, NASA NPR 8705.2B. Rev 1,12/ 2009.
 8. Goebel, D. M. and Katz, I., *Fundamentals of Electric Propulsion: Ion and Hall Thrusters*. John Wiley & Sons, New York, 2008.
 9. De Grys, K. H., et al., “4.5 kW Hall Thruster System Qualification Status,” AIAA Paper 2005-3682, July 2005.
 10. Welander, B. A. and De Grys, K. H., “Completion of the BPT-4000 Hall Thruster Qualification,” Presented at the 53rd JANNAF Propulsion Meeting, Monterey, CA, Dec. 5-8, 2005
 11. Manzella, D. H., Jankovsky, R. S., and Hofer, R. R., “Laboratory Model 50 kW Hall Thruster,” AIAA Paper 2002-3676, July 2002.
 12. Jankovsky, R., Tverdokhlebov, S., and Manzella, D., “High Power Hall Thrusters,” AIAA-99-2949, June 1999.
 13. Hamley, J. A., et al. “Hall Thruster Direct Drive Demonstration,” AIAA Paper 1997-2787, July 1997.
 14. Hoskins, W.A., et.al. “Direct Drive Hall Thruster System Development,” AIAA-2003-4726, July 2003.
 15. Hamley, J.A., “Direct Drive Options for Electric Propulsion Systems,” NASA TM 106576, 1995.
 16. Martini, M., “S.N.A.P. 2.3 User’s Manual, Spacecraft N-Body Analysis Program,” 2005.
 17. Sims, J.A., Finlayson, P.A., Rinderle, E.A., Vavrina, M.A., Kowalkowski, T.D. “Implementation of a low-thrust trajectory optimization algorithm for a preliminary design,” AIAA Paper 2006-2513, 2006.
 18. Adler, A.P, et. al. “Powersail: The Challenges of Large, Planar, Surface Structures for Space Applications,” AIAA Paper 2003-1823, 2003.
 19. Prior, T.G., “BUMPER II Training Guide,” version 1.79d. JSC-28725, 1999.
 20. Grun, E. Zook, H.A., Fechtig, H., and Giese, R.H., “Collisional balance of the meteoric complex,” *Icarus*, Vol. 62, 1985, pp. 244-274.
 21. Christiansen, E. “Meteoroids / Debris Shielding,” NASA/TP—2003-210788, 2003.
 22. Crofton, M.W. and Hain, T.D., “Environmental Considerations for Xenon Electric Propulsion,” the 30th International Electric Propulsion Conference, IEPC-2007-257, Sept. 2007.
 23. Karwacki, G., “Recovering Xenon – and Costs: A Special Report to Cryogas International,” CryoGas International, Vol. 47, No. 7, p. 39, July 2009.
 24. Welle, R.P., “Xenon and Krypton Availability for Electric Propulsion: An Updated Assessment,” AIAA-1993-2401, June 1993.

REPORT DOCUMENTATION PAGE			Form Approved OMB No. 0704-0188		
<p>The public reporting burden for this collection of information is estimated to average 1 hour per response, including the time for reviewing instructions, searching existing data sources, gathering and maintaining the data needed, and completing and reviewing the collection of information. Send comments regarding this burden estimate or any other aspect of this collection of information, including suggestions for reducing this burden, to Department of Defense, Washington Headquarters Services, Directorate for Information Operations and Reports (0704-0188), 1215 Jefferson Davis Highway, Suite 1204, Arlington, VA 22202-4302. Respondents should be aware that notwithstanding any other provision of law, no person shall be subject to any penalty for failing to comply with a collection of information if it does not display a currently valid OMB control number.</p> <p>PLEASE DO NOT RETURN YOUR FORM TO THE ABOVE ADDRESS.</p>					
1. REPORT DATE (DD-MM-YYYY) 01-02-2012		2. REPORT TYPE Technical Memorandum		3. DATES COVERED (From - To)	
4. TITLE AND SUBTITLE Feasibility of Large High-Powered Solar Electric Propulsion Vehicles: Issues and Solutions			5a. CONTRACT NUMBER		
			5b. GRANT NUMBER		
			5c. PROGRAM ELEMENT NUMBER		
6. AUTHOR(S) Capadona, Lynn, A.; Woytach, Jeffrey, M.; Kerslake, Thomas, W.; Manzella, David, H.; Christie, Robert, J.; Hickman, Tyler, A.; Scheidegger, Robert, J.; Hoffman, David, J.; Klem, Mark, D.			5d. PROJECT NUMBER		
			5e. TASK NUMBER		
			5f. WORK UNIT NUMBER WBS 432938.08.01.03.02		
7. PERFORMING ORGANIZATION NAME(S) AND ADDRESS(ES) National Aeronautics and Space Administration John H. Glenn Research Center at Lewis Field Cleveland, Ohio 44135-3191			8. PERFORMING ORGANIZATION REPORT NUMBER E-18030		
9. SPONSORING/MONITORING AGENCY NAME(S) AND ADDRESS(ES) National Aeronautics and Space Administration Washington, DC 20546-0001			10. SPONSORING/MONITOR'S ACRONYM(S) NASA		
			11. SPONSORING/MONITORING REPORT NUMBER NASA/TM-2012-217275		
12. DISTRIBUTION/AVAILABILITY STATEMENT Unclassified-Unlimited Subject Categories: 18 and 20 Available electronically at http://www.sti.nasa.gov This publication is available from the NASA Center for AeroSpace Information, 443-757-5802					
13. SUPPLEMENTARY NOTES					
14. ABSTRACT Human exploration beyond low Earth orbit will require the use of enabling technologies that are efficient, affordable, and reliable. Solar electric propulsion (SEP) has been proposed by NASA's Human Exploration Framework Team as an option to achieve human exploration missions to near Earth objects (NEOs) because of its favorable mass efficiency as compared to traditional chemical systems. This paper describes the unique challenges and technology hurdles associated with developing a large high-power SEP vehicle. A subsystem level breakdown of factors contributing to the feasibility of SEP as a platform for future exploration missions to NEOs is presented including overall mission feasibility, trip time variables, propellant management issues, solar array power generation, array structure issues, and other areas that warrant investment in additional technology or engineering development.					
15. SUBJECT TERMS Solar electric propulsion					
16. SECURITY CLASSIFICATION OF:			17. LIMITATION OF ABSTRACT UU	18. NUMBER OF PAGES 22	19a. NAME OF RESPONSIBLE PERSON STI Help Desk (email:help@sti.nasa.gov)
a. REPORT U	b. ABSTRACT U	c. THIS PAGE U			19b. TELEPHONE NUMBER (include area code) 443-757-5802

