

NEW GAS POLAROGRAPHIC HYDROGEN SENSOR

Jesús A. Dominguez, Ron Barile
ASRC Aerospace Corporation
Kennedy Space Center, Mail Stop ASRC-28.
Kennedy Space Center, Florida 32899

Abstract

Polarography is the measurement of the current that flows in solution as a function of an applied voltage. The actual form of the observed polarographic current depends upon the manner in which the voltage is applied and on the characteristics of the working electrode. The new gas polarographic H₂ sensor shows a current level increment with concentration of the gaseous H₂ similar to those relating to metal ions in liquid electrolytes in well-known polarography. This phenomenon is caused by the fact that the diffusion of the gaseous H₂ through a gas diffusion hole built in the sensor is a rate-determining step in the gaseous-hydrogen sensing mechanism. The diffusion hole artificially limits the diffusion of the gaseous H₂ toward the electrode located at the sensor cavity.

This gas polarographic H₂ sensor is actually an electrochemical-pumping cell since the gaseous H₂ is in fact pumped via the electrochemical driving force generated between the electrodes. Gaseous H₂ enters the diffusion hole and reaches the first electrode (anode) located in the sensor cavity to be transformed into an H⁺ ions or protons; H⁺ ions pass through the electrolyte and reach the second electrode (cathode) to be reformed to gaseous H₂.

Gas polarographic O₂ sensors are commercially available; a gas polarographic O₂ sensor was used to prove the feasibility of building a new gas polarographic H₂ sensor.

Background.

Gas polarographic O₂ sensors are commercially available; a gas polarographic O₂ sensor was used to prove the feasibility of building a new gas polarographic H₂ sensor. Figure 1 shows a schematic diagram of the commercial gas polarographic O₂ sensor. The sensor consists of an electrochemical O₂-pumping cell and a cap with a cylindrical gas diffusion hole for the artificial diffusion control of the gaseous O₂. A tiny heater is mounted on the cap of the sensor to keep the sensor temperature at 400-450 °C. The O₂-pumping cell has the form of a thick disk of 450-500- μ m thickness and 60-70- μ m diameter and is made of yttria-stabilized zirconia (YSZ); porous platinum

electrodes are attached to both sides of the electrolyte disk. The voltage is applied so that the electrode in the sensor cavity is negative (cathode) to control the diffusion of gaseous O₂ and reduce it to negative O₂ ions. These negative ions pass through the YSZ electrolyte and reach the positive electrode (anode), where they subsequently reform to gaseous O₂.

In existing and commercially available gas polarographic O₂ sensors, the electrode in the sensor cavity has to be negative (cathode) as gaseous O₂ is reduced to negative ions (O₂⁻) at the cathode. In contrast, a gas polarographic H₂ sensor should have the positive electrode (anode) in the sensor cavity as gaseous H₂ needs to release electrons and generate H⁺ ions or protons. These H⁺ ions (or protons) should pass through the YSZ electrolyte to the negative electrode (cathode), where they subsequently reform to gaseous H₂. Figure 2 shows a schematic diagram of the new gas polarographic H₂ sensor. This gas polarographic hydrogen sensor is actually an electrochemical-pumping cell since the gaseous H₂ is in fact pumped via the electrochemical driving force generated between electrodes.

YSZ is used as electrolyte in most of the commercial gas polarographic O₂ sensors as well as in Solid Oxide Fuel Cells (SOFC) because of its excellent oxygen ion (O₂⁻) conductivity. YSZ should be also a protonic (H⁺) conductor to use it as electrolyte in the new gas polarographic H₂ sensor. The conduction of protons through solid oxide electrolytes has been subject of some discussion, and it is generally believed to occur through a "hopping" mechanism. In this the conduction occurs by the proton associating with an oxygen atom, forming a transient hydroxyl specie that is "transported" through the material by the migration of the hydrogen ion from one oxygen atom to a neighboring oxygen atom. Since the exact details remain unclear, dynamic quantum mechanical modeling would be needed to understand the mechanism of proton conduction. Recent research has reported electrochemical properties of different ceramic protonic conductors and the feasibility of H₂ pumping for the purpose of tritium extraction in fusion fuel systems.

Sensing Mechanism.

Having a gas binary system and assuming steady-state conditions, no reaction, stagnant background gas, and mass transfer only in one direction and rate-limited at the diffusion

hole, the limiting output current is predicted to be a linear function of the logarithm of the background gas concentration. See enclosed appendix A for detailed derivation of this function. This linear relation between the output limiting current and the logarithm of the background molar fraction has a slope that includes the area and the length of the gas diffusion hole, the gas pressure, the gas temperature, the diffusion coefficient of the gaseous specie in the binary gas mixture, the Faraday constant, and the number of electrons per mole of the gaseous specie transferred between electrodes (this number is 4 for O₂ and 2 for H₂ as indicated in figures 1 and 2 respectively).

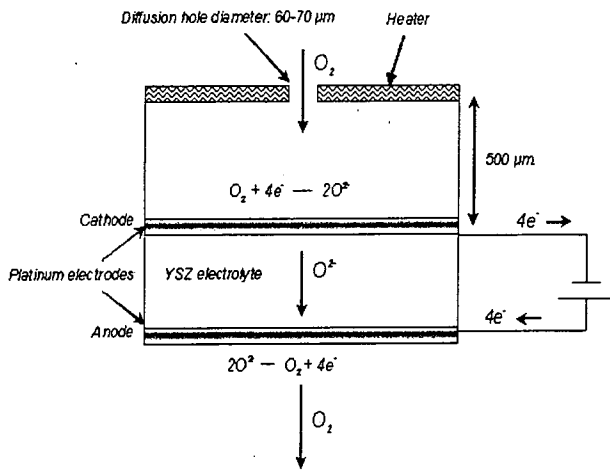

Figure 1. Schematic diagram of commercially available gas polarographic O₂ sensor.

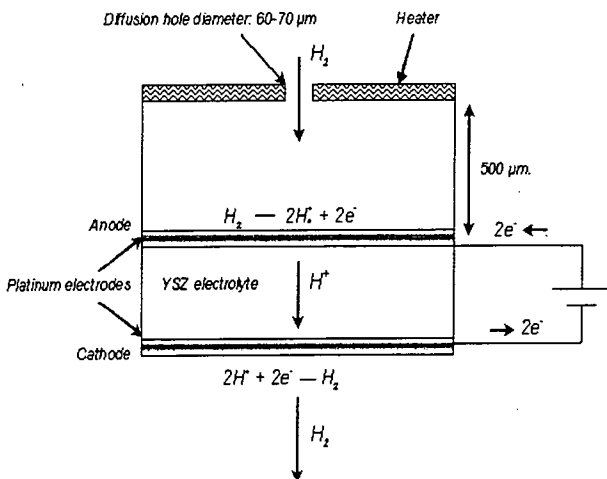

Figure 2. Schematic diagram of new gas polarographic H₂ sensor.

It is generally known that YSZ exhibits purely oxygen ionic conduction (with no electronic conduction) over a wide range

of oxygen partial pressures. Researchers have corroborated that YSZ is also a protonic conductor. Research work is currently oriented to build a ceramic electrolyte that can perform proton conduction at temperatures lower than those needed with YSZ. Further research might lead to the feasibility of building ceramic materials with hydrogen pumping capabilities for the purpose of tritium extraction in fusion fuel systems.

Results.

Plot 1 displays the voltage-current characteristics of the commercial gas polarographic O₂ sensor. Plot 2 shows the voltage-current characteristics of the gas polarographic H₂ sensor in H₂-N₂ gas mixtures (from 0-3% H₂) when voltage is applied so that the electrode in the sensor cavity is positive (see figure 2) in order to control the diffusion of gaseous H₂. As expected, limiting current proved to be dependent on H₂ composition and increased with increasing H₂ concentration in the ambient gas mixture. However, plot 2 does not show defined limiting-current plateaus similar to those shown in plot 1. In both cases we used the same sensor with a difference only on the electrode polarity. The size of the diffusion hole (60-70-μm diameter) was actually designed by the sensor manufacturer to limit diffusion of O₂-size molecules. A gas polarographic H₂ sensor with a smaller diffusion hole (20-30-μm diameter) should lead to defined limiting-current plateaus.

Plots 3 and 4 show output current generated by the gas polarographic H₂ sensor at different ambient H₂ concentrations (from 0.25-2.0% H₂) using 0.3 and 0.6 volts respectively. As in plot 2, plots 3 and 4 show results generated by a gas polarographic H₂ sensor having the positive electrode (anode) in the sensor cavity (see figure 2). As expected, the output limiting current proved to be dependent on H₂ composition; the output limiting current is increased as the gaseous H₂ concentration increases. As in the case of the gas polarographic O₂ sensing, a linear relation between the output limiting current and the logarithm of the mole fraction of the background gas was also observed for the gas polarographic H₂ sensing as shown in plot 5; further test runs and precise measurements of the diameter and the length of the diffusion hole are required to corroborate this linear relation (see appendix A). The output-current response peaks shown in plots 3 and 4 should be attenuated with a smaller diffusion hole; 20-30 μm might be a suitable diffusion hole diameter for a gas polarographic H₂ sensor. As mentioned above, the size of the diffusion hole (60-70-μm diameter) was actually designed to limit diffusion of O₂-size molecules.

Plot 6 shows output current generated by the above sensor but having the negative electrode (cathode) in the sensor cavity as set up in the gas polarographic O₂ sensor. The output limiting current shows no dependency on H₂ concentration proving that limiting-current mechanism on a

H₂ pumping cell can be possible only if the positive electrode (anode) is in the sensor cavity.

The above results show that if the diffusion of gaseous H₂ is artificially controlled and a protonic conductor is used as electrolyte, a gaseous H₂ sensor might be built based on a gaseous H₂-sensing mechanism attained on the analogy of the widely known O₂-sensing mechanism.

Based on the results shown in this H₂ sensing approach along with what is already known from the gas polarographic O₂ sensor, the concept of polarography should be reconsidered and redefined to be classified in two types—gas polarography and the liquid polarography—on the basis of the phase of the measured substance, the diffusion of which is a rate-determining step. For example, the concept of chromatography is well defined and clearly divided into the gas chromatography and liquid chromatography because of the kind of mobile phase. Thus, taking analogous consideration, this proposal is clearly reasonable.

Research and development on solid materials that can perform proton conducting at intermediate temperature have dramatically increased due to the renewed interest in the industry for solid-electrolyte fuel cells. Commercially available Proton Exchange Membranes (PEM) might be utilized as solid-electrolyte in the gas polarographic H₂ sensor. PEM performs proton conducting at relatively low temperature (5-120 °C). Research on new zirconia-based electrolyte materials are currently focus on obtaining materials that can perform proton conducting at intermediate temperature; YSZ, the electrolyte currently used in SOFC and commercial gas polarographic O₂ sensor, requires temperatures higher than 400 °C. Figure 3 shows the proton conductivity of BCY and SCZT85 (two new zirconia-based materials) along with YSZ proton conductivity^[1].

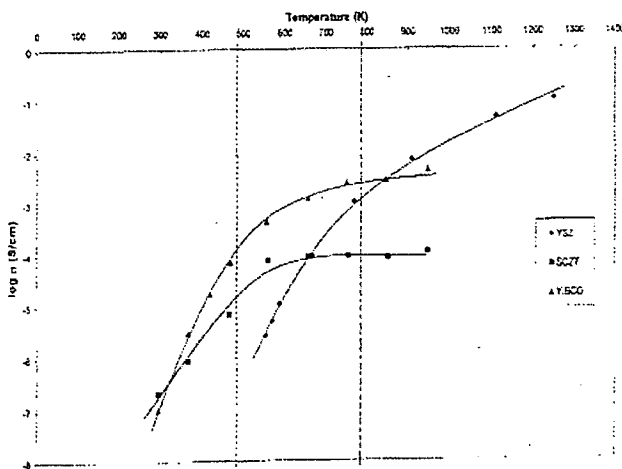

Figure 3. Proton Conductivity of BCY, SCZT85 and YSZ with Temperature^[1].

Conclusion.

The engineering and manufacturing requirements of this new gas polarographic H₂ sensor would be basically the same as those already in place for the commercially available gas polarographic O₂ sensors. The gas polarographic H₂ sensor would need a smaller diffusion hole and the anode in the sensor cavity. Further research is needed to determine the proper size of the diffusion hole and evaluate different types of solid electrolytes including electrolytes with more H⁺ ion and less O²⁻ ion conduction selectivity and capable of conducting protons at lower temperatures.

An array of two gas polarographic sensors with different diffusion hole sizes and voltage polarities might be able to detect three components—O₂, H₂, and humidity. A smart sensing system equipped with the proper algorithm might be able to extract mutual cross-sensitivity interference of H₂ and humidity on the O₂ sensor and O₂ and humidity on the H₂ sensor.

References.

- [1] D. Browning, M. Weston, J.B. Lakeman, P. Jones, M. Cherry, J. T. S. Irvine, D. J. D. Corcoran; "Proton Conducting Ceramics for Use in Intermediate Temperature Proton Conducting Fuel Cells", *Journal of New Material for Electrochemical Systems*, 5, page 28 (2002).
- [2] K. Lundstrom, M. Shivaraman, and C. Svenson, *J. Appl. Phys.*, 46, 3976 (1975).
- [3] Y. Tan, T. C. Tan; "Sensing Behavior of an Amperometric Hydrogen Sensor", *J. Electrochem. Soc.*, Vol 142, No 6, June 1995.
- [4] T. Usui, A. Asada, K. Ishibashi, M. Nakazaka, "Humidity Sensing Characteristics in a wet air of a gas polarographic Oxygen Sensor Using Zirconia Electrolyte", *Electrochem. Soc.* 138 (1991) 585-588.
- [5] J. Gopaul, W. C. Maskell, K. E. Pitt, "Planar Oxygen Sensor: Part I. Effect of Crazing of Zirconia Thick Film on an Alumina Substratum", *J. Appl. Electrochem.*, 29 (1999) 93-100.

Commercial 5%-O₂-range Sensor: Limiting Current Profile.
Gas: O₂ in N₂, 27C, 760 Torr, 6000 sccm, April 8, 2002

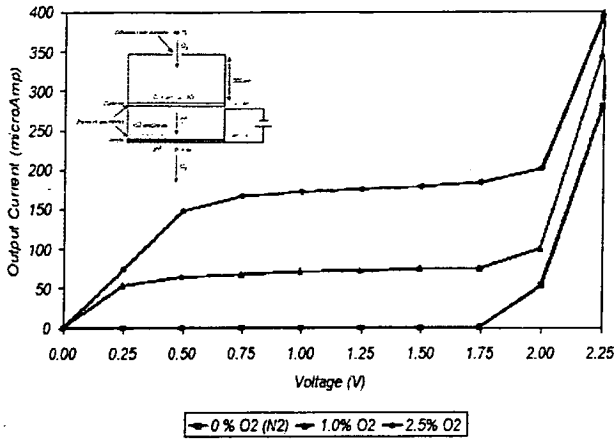

Plot 1. O₂ Limiting Current Profile

Gas Polarographic H₂ Sensor via YSZ Electrolyte: Limiting Current Profile.
Gas: H₂ in N₂, 27C, 768 Torr, 6000 sccm, May 20, 2002

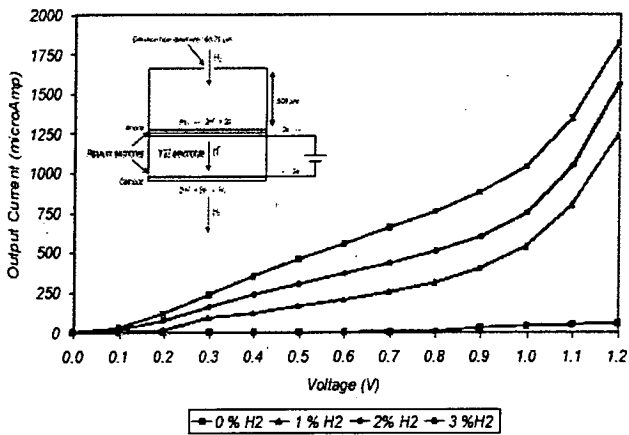

Plot 2. H₂ Limiting Current Profile.

Gas Polarographic H₂ Sensor: 0.3 Volts, Anode in Sensor Cavity.
Gas: H₂ in N₂, 27C, 768 Torr, 6000 sccm, May 20, 2002

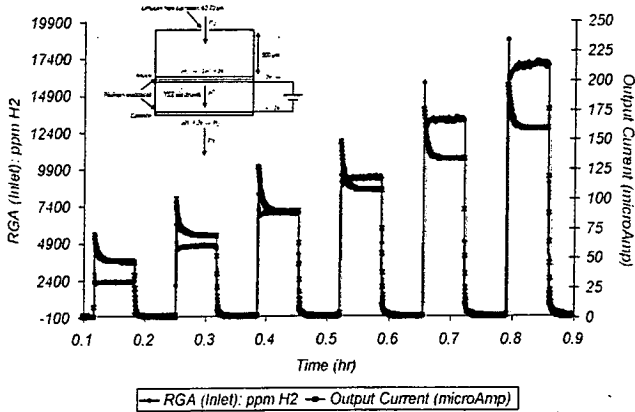

Plot 3. H₂ measurement profile at 0.3 V with anode in sensor cavity.

Gas Polarographic H₂ Sensor: 0.6 Volts, Anode in Sensor Cavity.
Gas: H₂ in N₂, 27C, 768 Torr, 6000 sccm, May 22, 2002

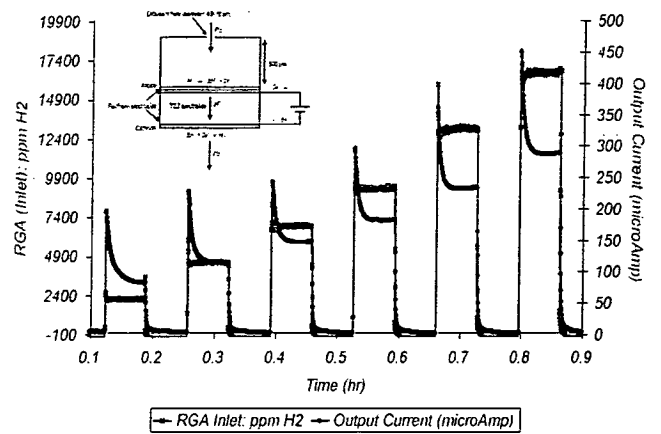

Plot 4. H₂ measurement profile at 0.6 V with anode in sensor cavity.

Gas Polarographic H₂ Sensor: Predicted vs. Experimental Performance
Gas: H₂ in N₂, 27 C, 768 Torr, 6000 sccm, May 2002.

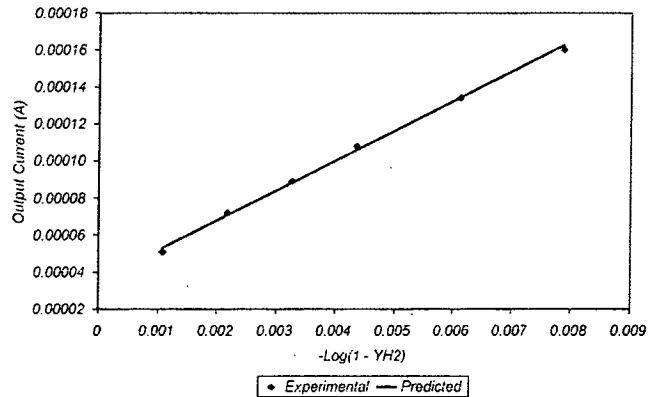

Plot 5. Experimental vs Predicted results.

Gas Polarographic H₂ Sensor: 0.6 Volts, Cathode in Sensor Cavity.
Gas: H₂ in N₂, 27C, 768 Torr, 6000 sccm, May 20, 2002

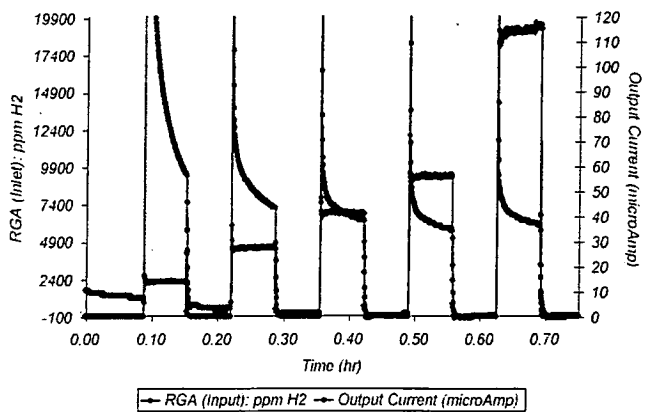

Plot 6. H₂ measurement profile at 0.6 V with cathode in sensor cavity.

APPENDIX A

Gas Polarographic Sensor: Theoretical Mechanism

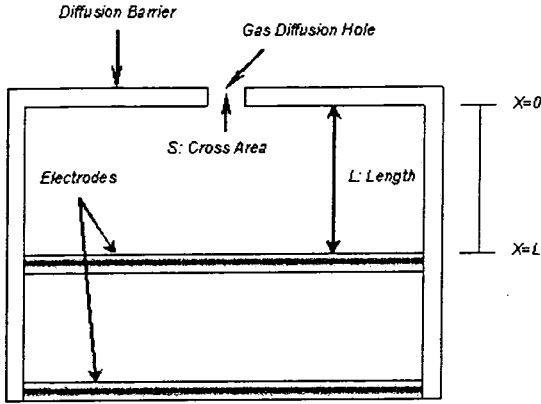

Assuming a binary mixture (A and B where B is the background gas). The limiting current is expressed as:

$$I_L = IFSN_A(x=L) \quad (1)$$

Where

- I_L Limiting current.
- I Number of electrons per mole of specie A transferred from the anode to the cathode.
 $I = 4$ if A specie is O_2 ($O_2 + 4e^- \rightarrow 2O^{2-}$).
 $I = 2$ if A specie is H_2 ($2H^+ + 2e^- \rightarrow H_2$).
- F Faraday constant (electrical charge of a mole of electrons).
- S Cross area of diffusion barrier.
- $N_A(x=L)$ Molar flux of specie A at the electrode.

The general equation for molar flux of specie A (N_A) can be expressed as:

$$\partial C_A / \partial t + (\partial N_{Ax} / \partial x + \partial N_{Ay} / \partial y + \partial N_{Az} / \partial z) = R_A \quad (2)$$

Where

- C_A Molar concentration of specie A.
- N_{Ax} , N_{Ay} , and N_{Az} Molar flux of specie A in x, y, and z directions.

R_A

Reaction of specie A.

Assuming steady state conditions, no reaction, and mass transfer only in one direction (x direction) equation (2) becomes:

$$\partial N_{Ax} / \partial x = 0 \quad (3)$$

Assuming a binary system denoting A as the component being measured and B as the background gas, N_{Ax} can be expressed as:

$$N_A = -CD_{AB} \partial Y_A / \partial x + Y_A(N_A + N_B) \quad (4)$$

Where:

- N_A Molar flux of specie A.
- N_B Molar flux of specie B.
- C Molar concentration.
- D_{AB} Diffusion coefficient of A into B.
- Y_A Molar fraction of specie A.

Assuming specie B (background gas) is stagnant ($N_B = 0$), equation 4 becomes:

$$N_A = -CD_{AB} \partial Y_A / \partial x + Y_A N_A \quad (5)$$

Rearranging equation (5):

$$N_A = -[CD_{AB} / (1 - Y_A)] \partial Y_A / \partial x \quad (6)$$

Substituting equation (6) into equation (3):

$$\partial \{ [CD_{AB} / (1 - Y_A)] \partial Y_A / \partial x \} / \partial x = 0 \quad (7)$$

Integrating (7) once:

$$[1 / (1 - Y_A)] \partial Y_A / \partial x = k_1 \quad (8)$$

After separating variables and integrating again:

$$-\ln(1 - Y_A) = K_1 x + k_2 \quad (9)$$

Using the boundary conditions $Y_A = Y_{A(amb.)}$ at $x=0$ and $Y_A = Y_{A(x=L)}$ at $x=L$ we find constant K_1 and K_2 . $Y_{A(amb.)}$ is the

molar fraction of specie A in the ambient and $Y_{A(x=L)}$ is the molar fraction of specie A at the bottom of the diffusion hole and the top of the electrode.

$$K_1 = (1/L)\text{Ln}[(1 - Y_{A(\text{amb.})})/(1 - Y_{A(x=L)})] \quad (10)$$

$$K_2 = -\text{Ln}(1 - Y_{A(\text{amb.})}) \quad (11)$$

Substituting (10) into (8):

$$\partial Y_A / \partial x = (1/L) \text{Ln}[(1 - Y_{A(\text{amb.})})/(1 - Y_{A(x=L)})] \quad (12)$$

Substituting (12) into (6):

$$N_A = -(CD_{AB}/L)\text{Ln}[(1 - Y_{A(\text{amb.})})/(1 - Y_{A(x=L)})] \quad (13)$$

Assuming:

$Y_{A(x=L)} \ll Y_{A(\text{ambient})}$ and Ideal gas ($C = P/RT$) equation (13) becomes:

$$N_A = -[(PD_{AB})/(RTL)]\text{Ln}[1 - Y_{A(\text{amb.})}] \quad (14)$$

Substituting (14) into (1):

$$I_L = -[(nFSPD_{AB})/(RTL)]\text{Ln}[1 - Y_{A(\text{amb.})}] \quad (15)$$

Equation (15) states that the limiting current can be used to measure the composition of specie A since there is a linear relation between I_L (limiting current) and $\text{Ln}[Y_{A(\text{ambient})} - 1]$. The slope of this linear relation is $(nFSPD_{AB})/(RTL)$ leading to a limiting current dependence on the geometric of the diffusion hole ($L =$ length and $S =$ Cross area), pressure (P) temperature (T), specie A itself ($n =$ number of electrons per mole of specie A transferred from the anode to the cathode), and $D_{AB} =$ diffusion coefficient of A into B. To avoid the need of using these parameters and assuming that T , P , and D_{AB} remain unchanged during the measurement, equation (15) may be reduced to:

$$I_L = \{I_L^{(\text{Ref.})}/\text{Ln}[Y_{A(\text{amb.})}^{(\text{Ref.})} - 1]\} \text{Ln}[Y_{A(\text{amb.})} - 1] \quad (16)$$

Where

I_L	Limiting current at $Y_{A(\text{amb.})}$.
$Y_{A(\text{amb.})}$	Mole fraction of specie A.
$I_L^{(\text{Ref.})}$	Reference limiting current at $Y_{A(\text{amb.})}^{(\text{Ref.})}$.
$Y_{A(\text{amb.})}^{(\text{Ref.})}$	Reference mole fraction of specie A.

The reference limiting-current value ($I_L^{(\text{Ref.})}$) is often measured using a calibration gas containing a known composition value ($Y_{A(\text{amb.})}^{(\text{Ref.})}$) that is equal to the upper composition value of the sensor's range.