



**KSC Engineering Directorate
Materials Science Division**

Chemistry At Kennedy Space Center or The Chemistry of Getting into Space

Tim Griffin, Ph.D.

NASA, KSC

Chemical Analysis Section



September 2007



- **Earned Bachelor of Science Degree in Chemistry**
 - University of Kansas
- **Earned Ph.D. in Analytical Chemistry**
 - University of Florida
 - Focus of Mass Spectrometry Instrument Development
- **Areas of Work**
 - Chemistry of Failures on Center
 - Instrument Development



- **KSC Premier Spaceport**
 - Most Unmanned Flights Launched
 - All Manned Flights Launched

- **Unmanned**
 - Deep Space Exploration
 - Galactic Pair – Two Galaxies Interacting 
 - Spiral Galaxy – Ultraviolet Image of M81 Spiral Galaxy 



- **Past**

- Apollo ☐
- SkyLab and Apollo-Soyuz ☐

- **Present**

- Shuttle ☐
- International Space Station (ISS) ☐

- **Future**

- Aries/Orion – Moon and Beyond ☐

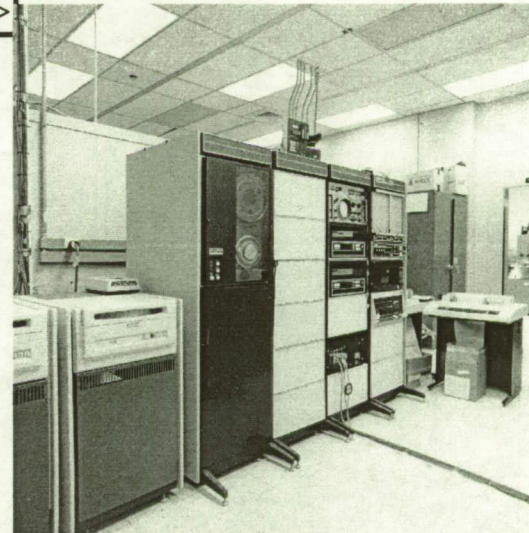



- **Different Areas of Materials Science Division**

- **Failure Analysis**

- Mechanical
- Electrical
- Materials

- **Metrology**

- Measure Dimensions

- **Physical Testing**

- Break Things

- **Rapid Prototyping**

- Concept to Final Product

- **Chemical Analysis**

- Determine What is What

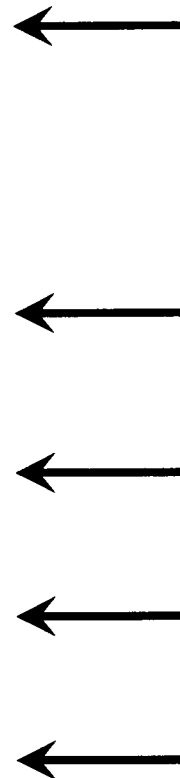

Work Together to Solve Problems

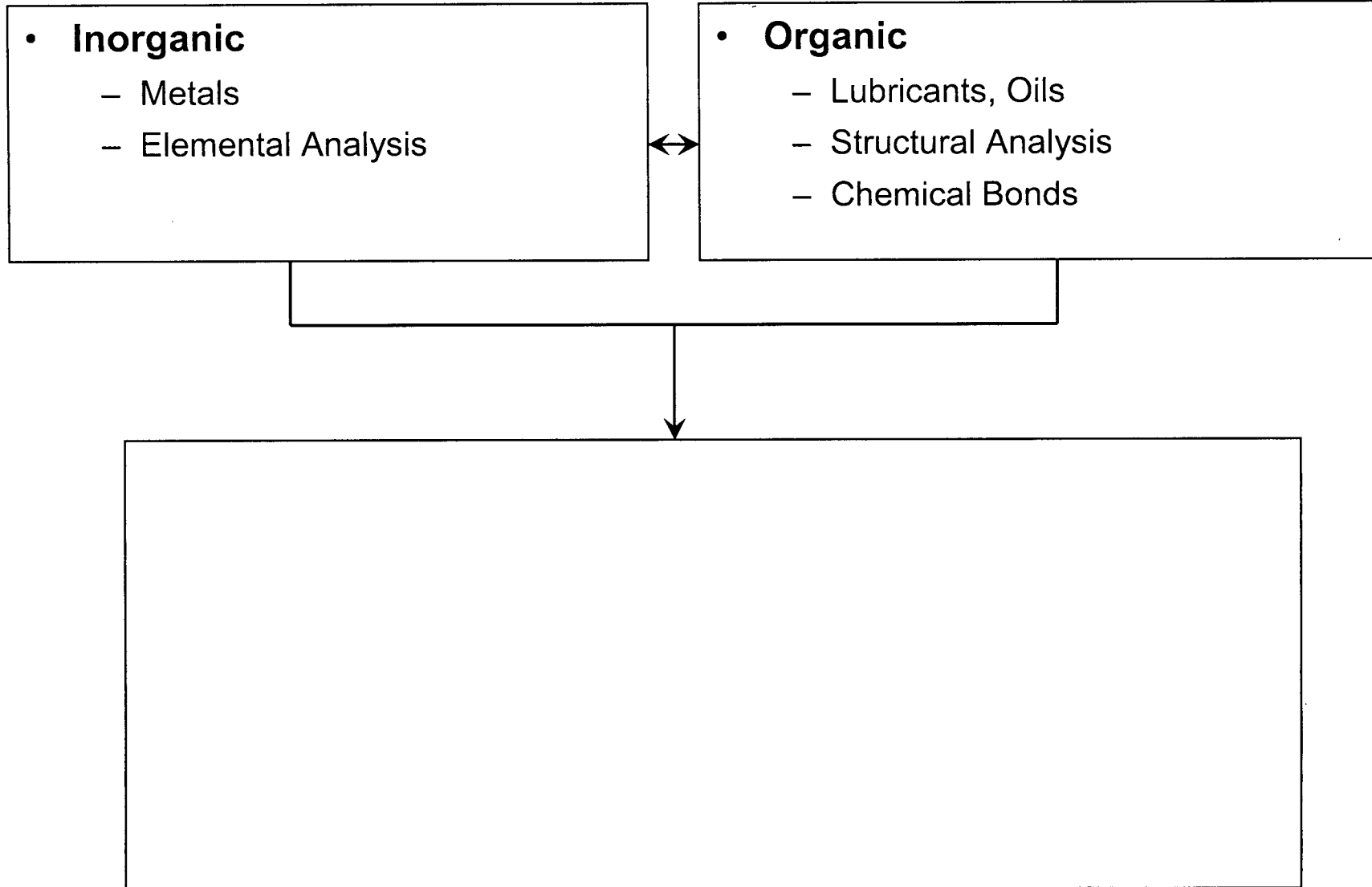



- **Elemental Analysis**
- **Bulk Analysis Techniques**
 - Inductively Couple Argon Plasma (ICAP)
 - Excellent Quantitation Technique/Destructive
 - Arc/Spark
 - Good Quantitation Technique/Damage Surface
 - X-ray Fluorescence (XRF)
 - Screen for Alloy Type/Non-Destructive
 - Ion Chromatography (IC)
 - Ions in Solution, Primarily water/Destructive
- **Small Area Analysis – Particle/Surface**
 - Scanning Electron Microscopy with Energy Dispersive Waveform Spectroscopy (SEM/EDS)
 - ID of Elements/Typically Non-Destructive, Must Fit in Chamber
 - High Magnification Pictures

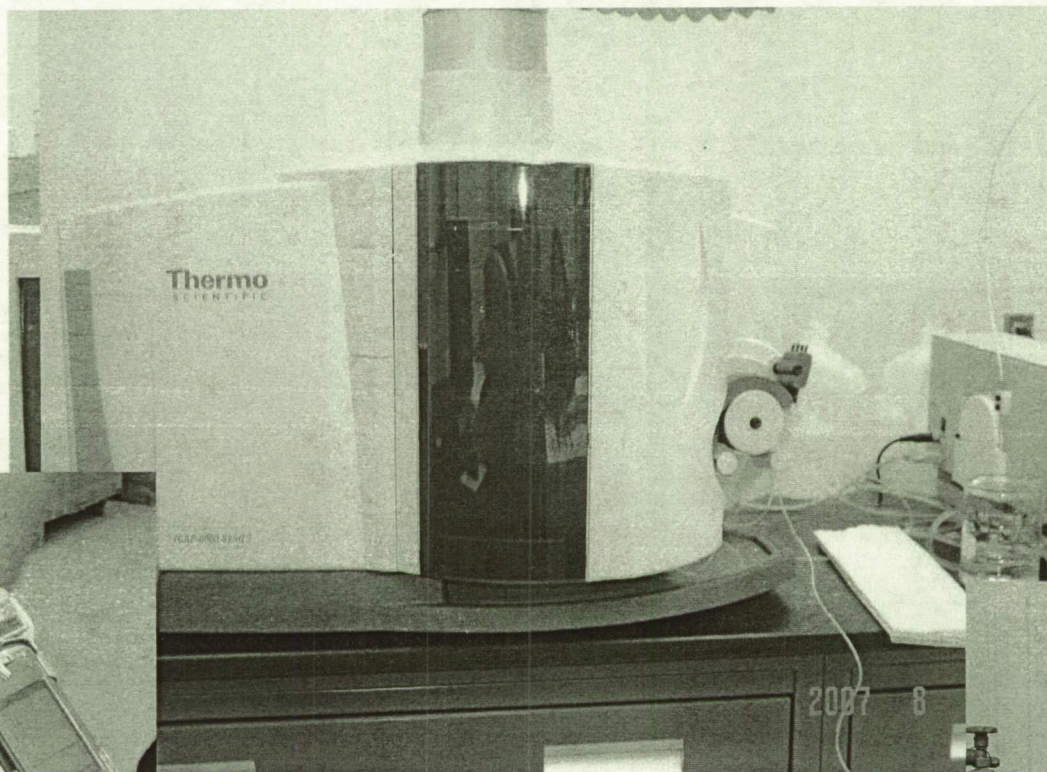

Inductively Couple
Argon Plasma
(ICAP)



X-ray Fluorescence
(XRF)

Arc/Spark

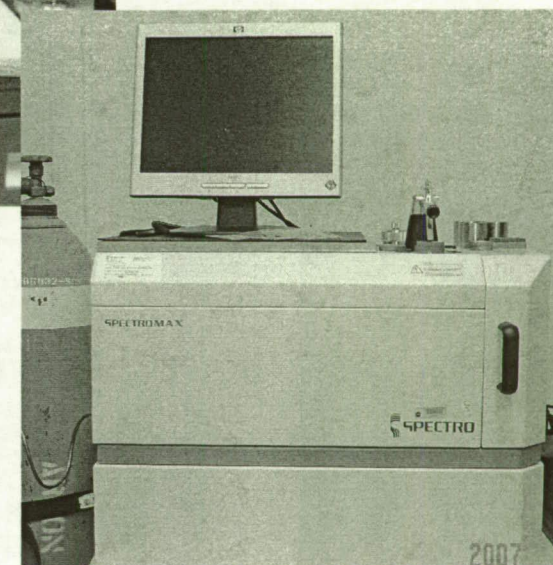

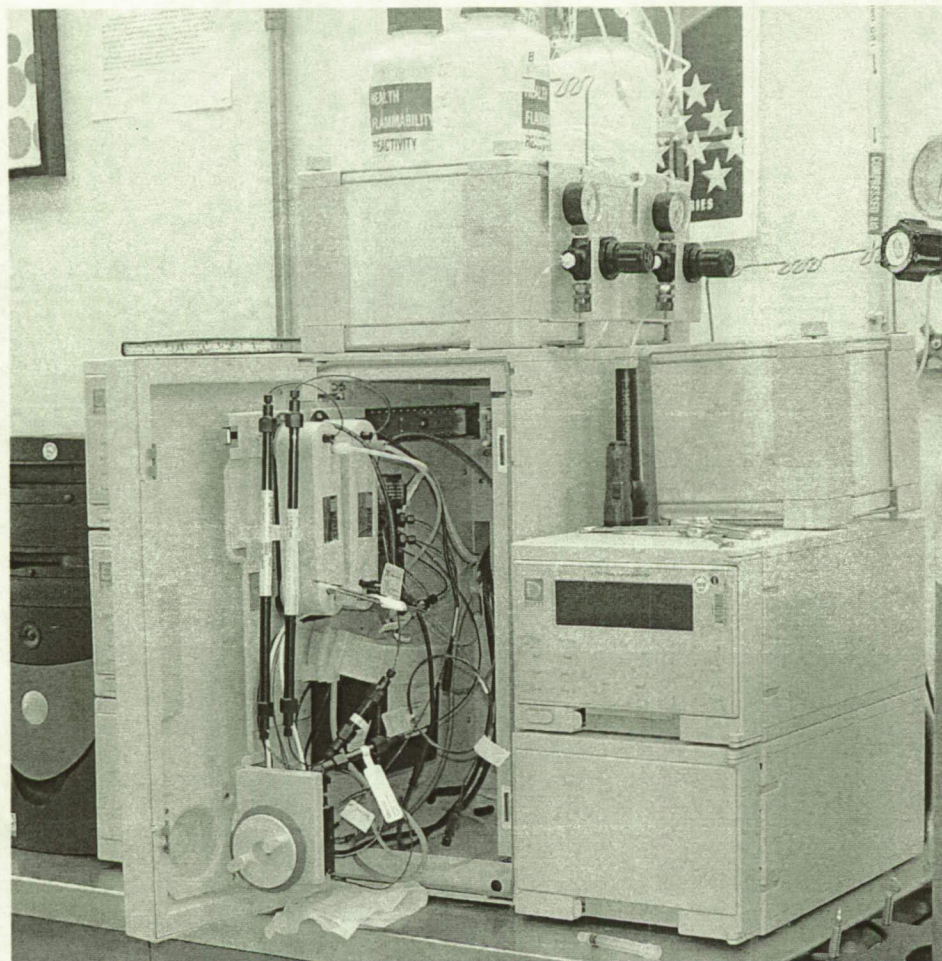

Ion Chromatography
(IC)

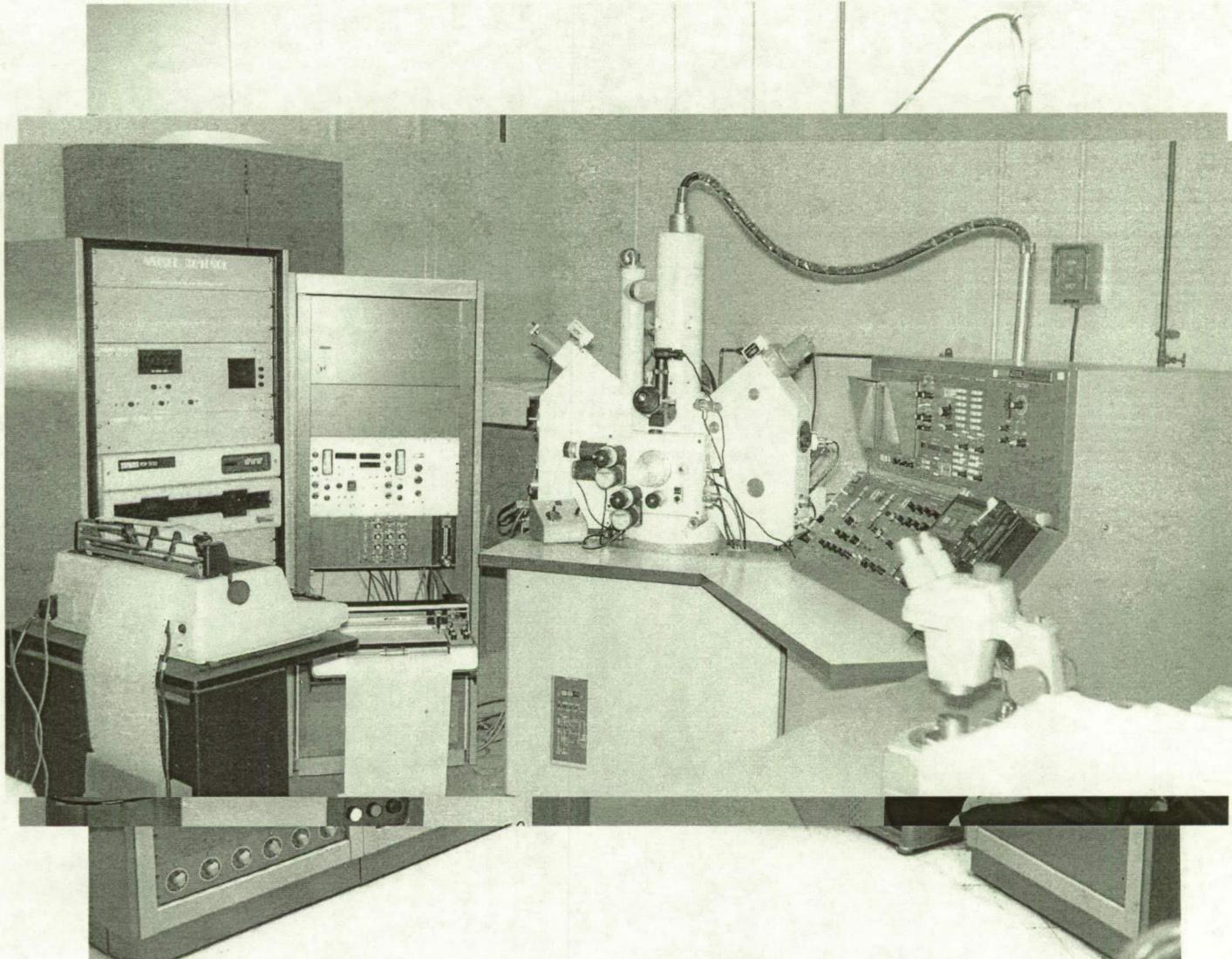



- **Analysis of Structure**
 - How elements are bonded together
 - Class type of compounds (e.g., paraffin, ester)
 - Chemical Formula
- **Bulk Analysis Techniques**
 - Fourier Transform Infrared Spectroscopy (FT-IR)
 - ID Compounds
 - Non-Destructive
 - Gas Chromatography/Mass Spectrometry (GC/MS)
 - ID Compounds
 - Quantitation
 - Low Level Analysis
 - Destructive



Fourier Transform Infrared Spectroscopy
(FT-IR)

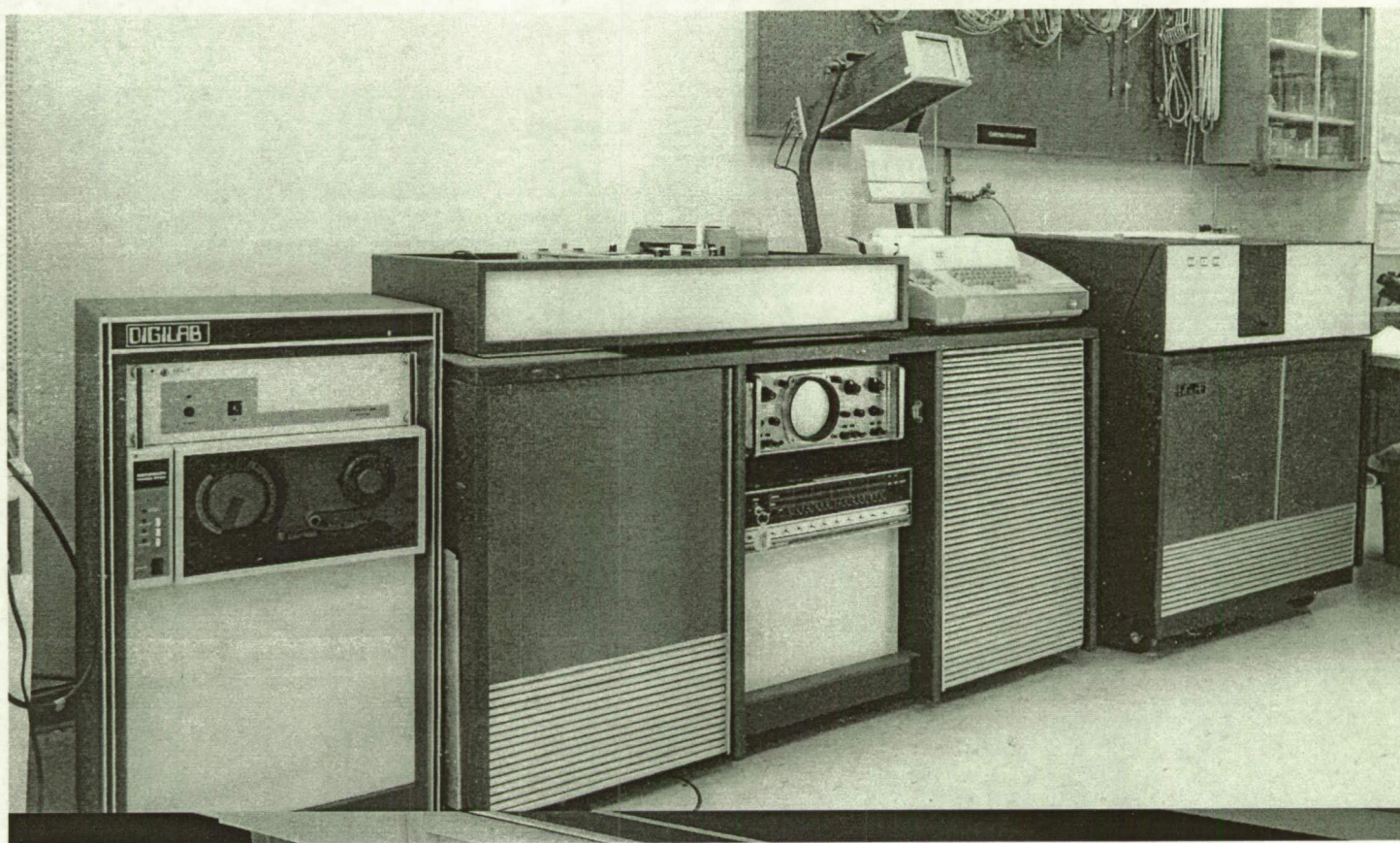



Gas Chromatography Mass Spectrometry
(GC/MS)

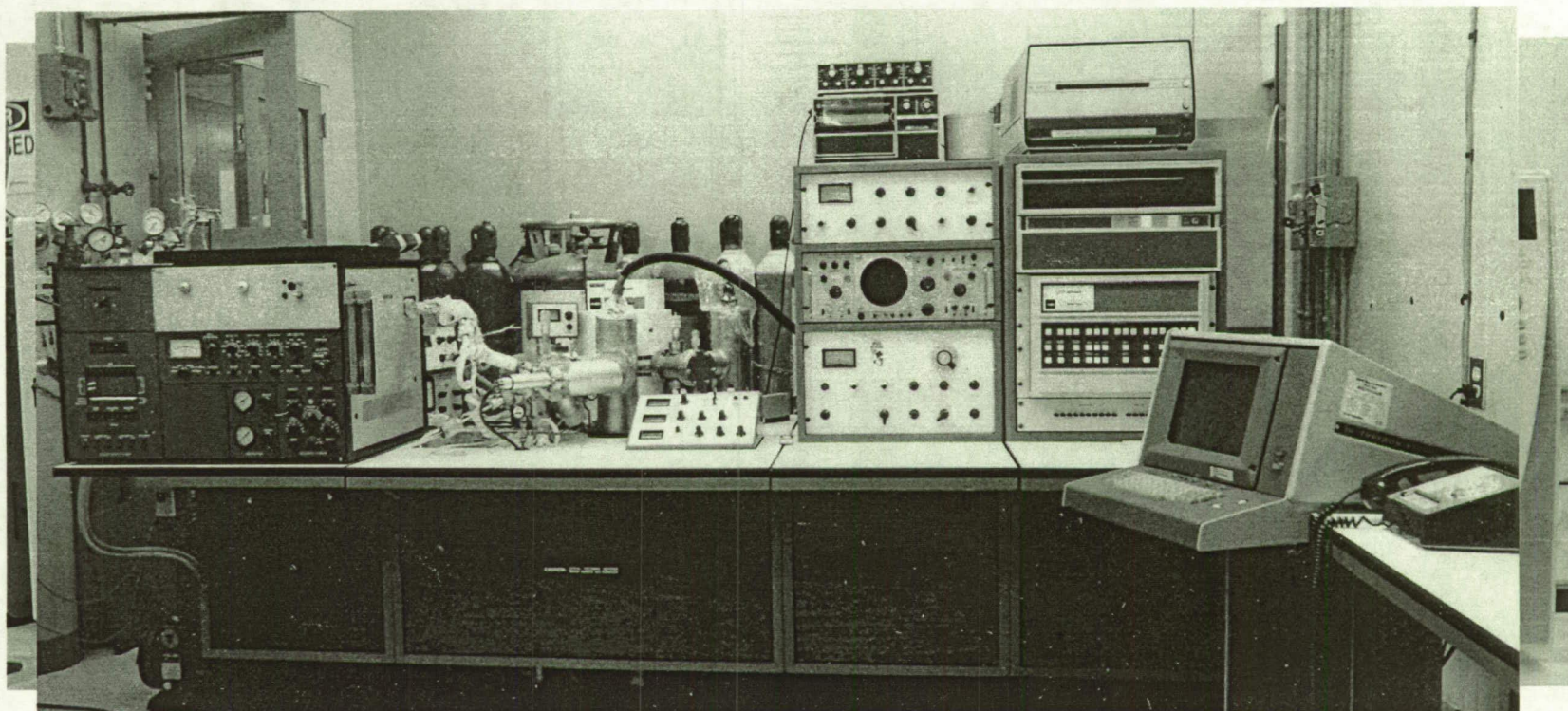

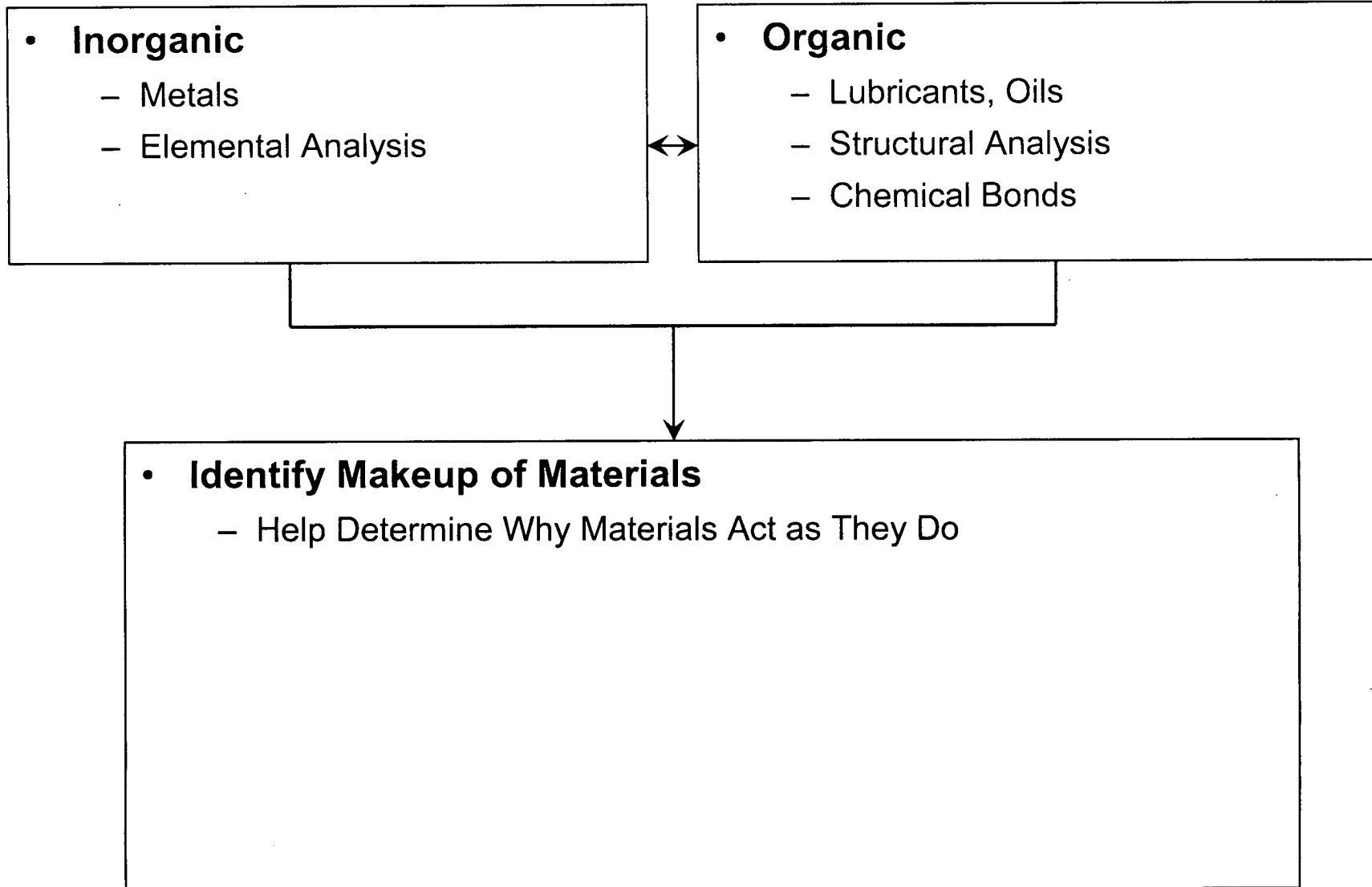



Work Flow (Composition of Material)

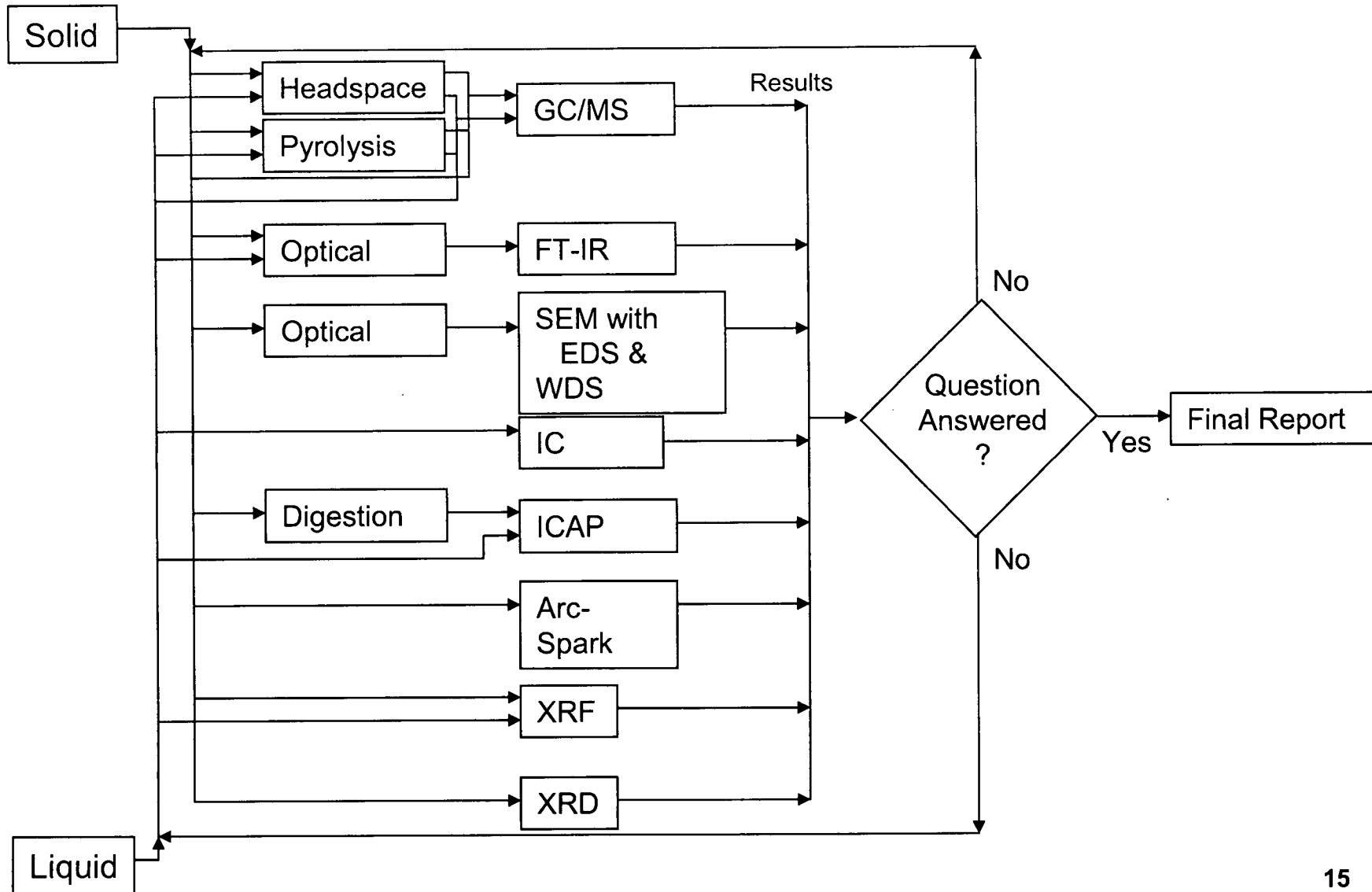



The Office of the Inspector General (IG) sent samples to the Material Science Laboratory to be analyzed and compared to specifications to ensure compliance for safety concerns.



Multi-discipline Analyses Required

- **Chemical Composition**
- **Coating Thickness Determination**
- **Hardness**
- **Tensile Strength**



Element	New Screw 1 (Element %)	Used Screw 15 (Element %)	Std. 8740 (Element %)	(AISI 8740) (Element %)
Carbon*	0.41	0.41	NA	0.38-0.43
Chromium	0.57	0.498	0.52	0.40-0.60
Manganese	0.84	0.85	0.89	0.75-1.00
Molybdenum	0.221	0.251	0.23	0.20-0.30
Nickel	0.437	0.446	0.51	0.40-0.70
Phosphorus	0.019	0.016	0.004	0.035 Max
Sulfur	0.008	0.029	0.019	0.040 Max
Silicon	0.313	0.233	0.252	0.15-0.35
Iron	Balance	Balance	Balance	Balance

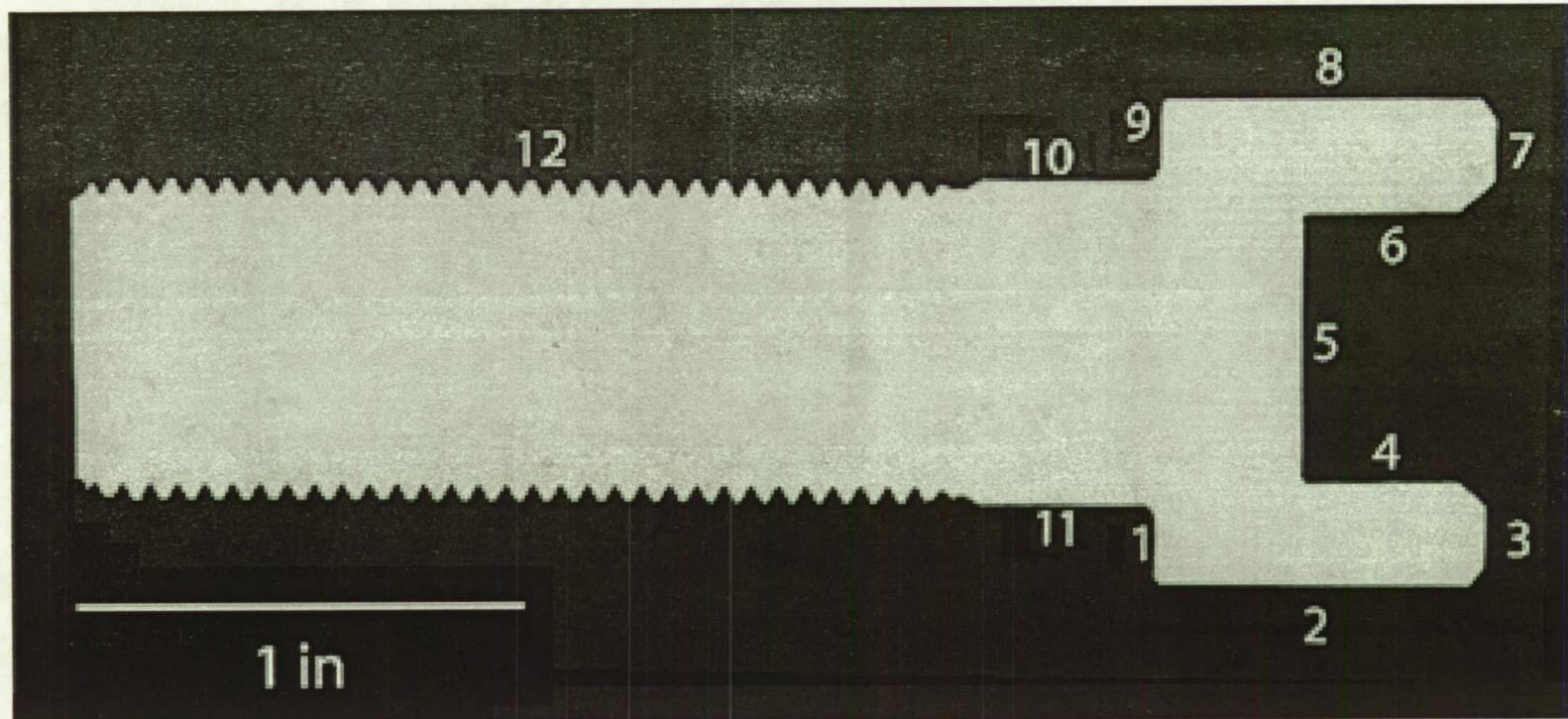



New Screw

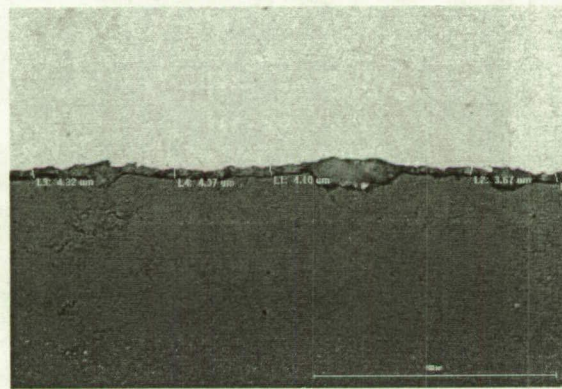

Used Screw

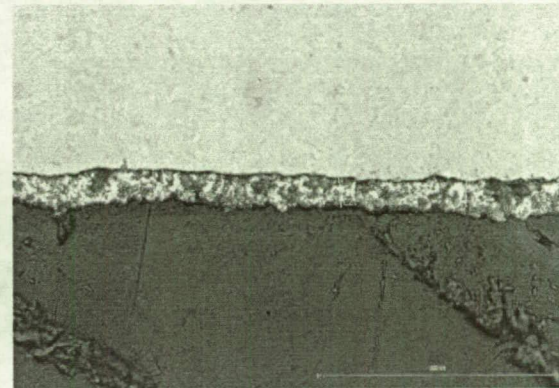
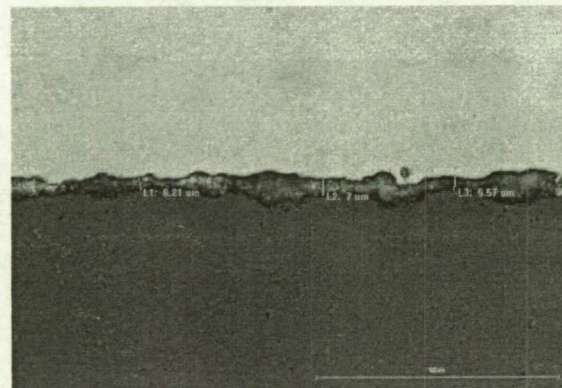
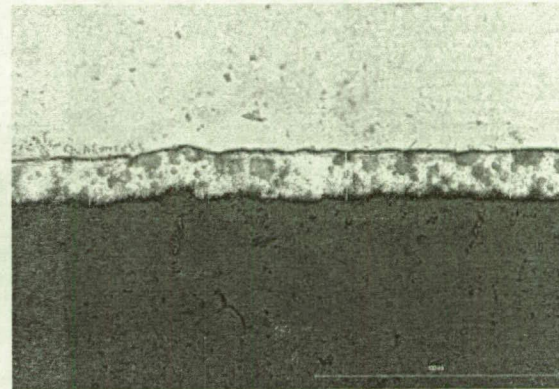



- **Chemical composition, hardness, and tensile strength meet design specifications.**
- **Cadmium coating thickness for the new lot of bolts was below specifications indicating potential corrosion problems.**

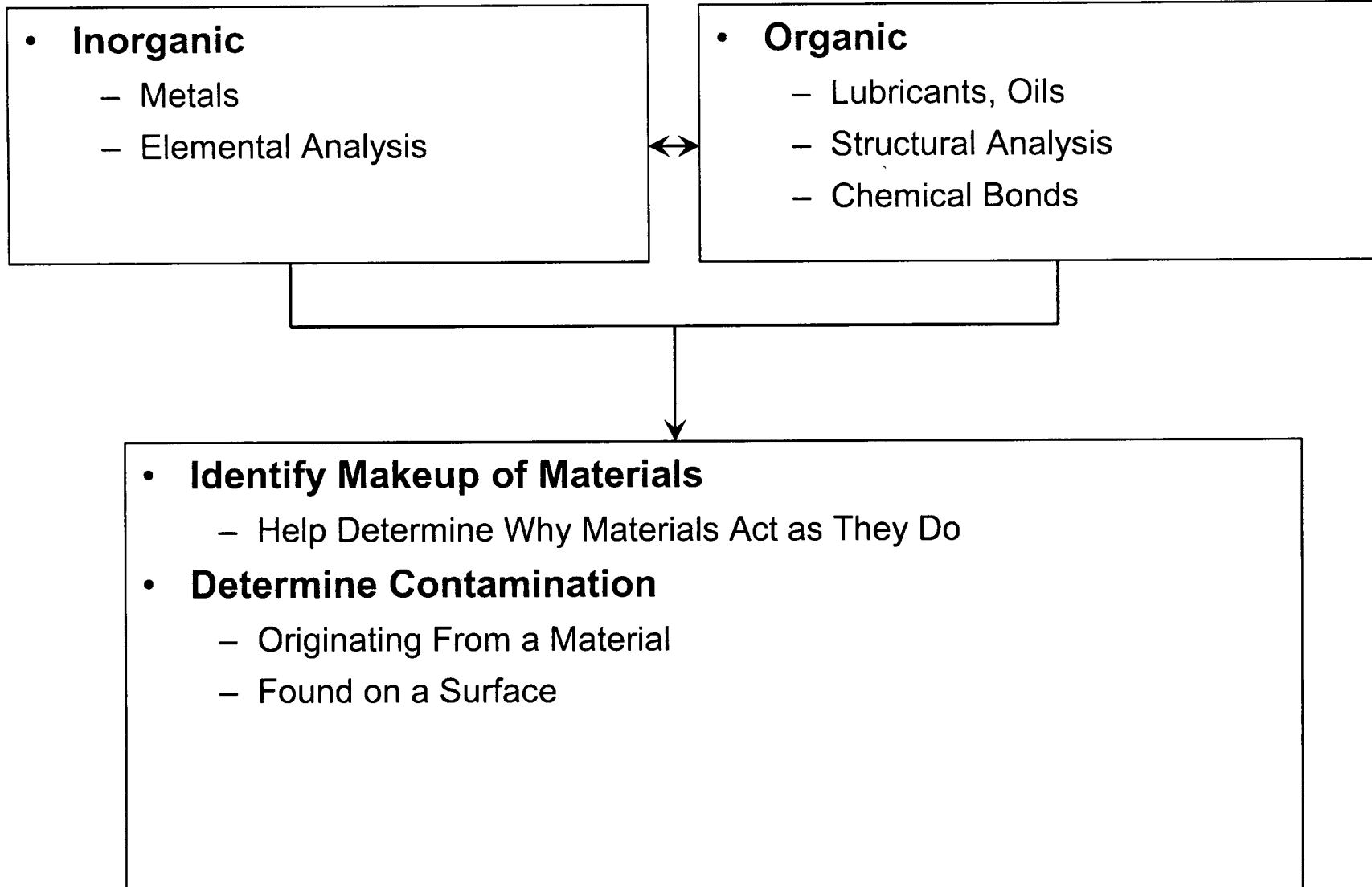



- **Examine Utilizing Inorganic and Organic Methods**
 - Same or similar techniques as examining materials
 - Sample extraction often required for Organic contamination
- **One of the Most Often Requested**
- **Used to Determine Origin of Contamination**
 - Compare contamination against possible sources
 - Original ID can help narrow possible sources
- **Sample Can Be Obtained By Wipes or Swabs**
 - Require a blank, unused, wipe or swab
 - Ensure focus analysis on contamination



Work Flow (Contamination)

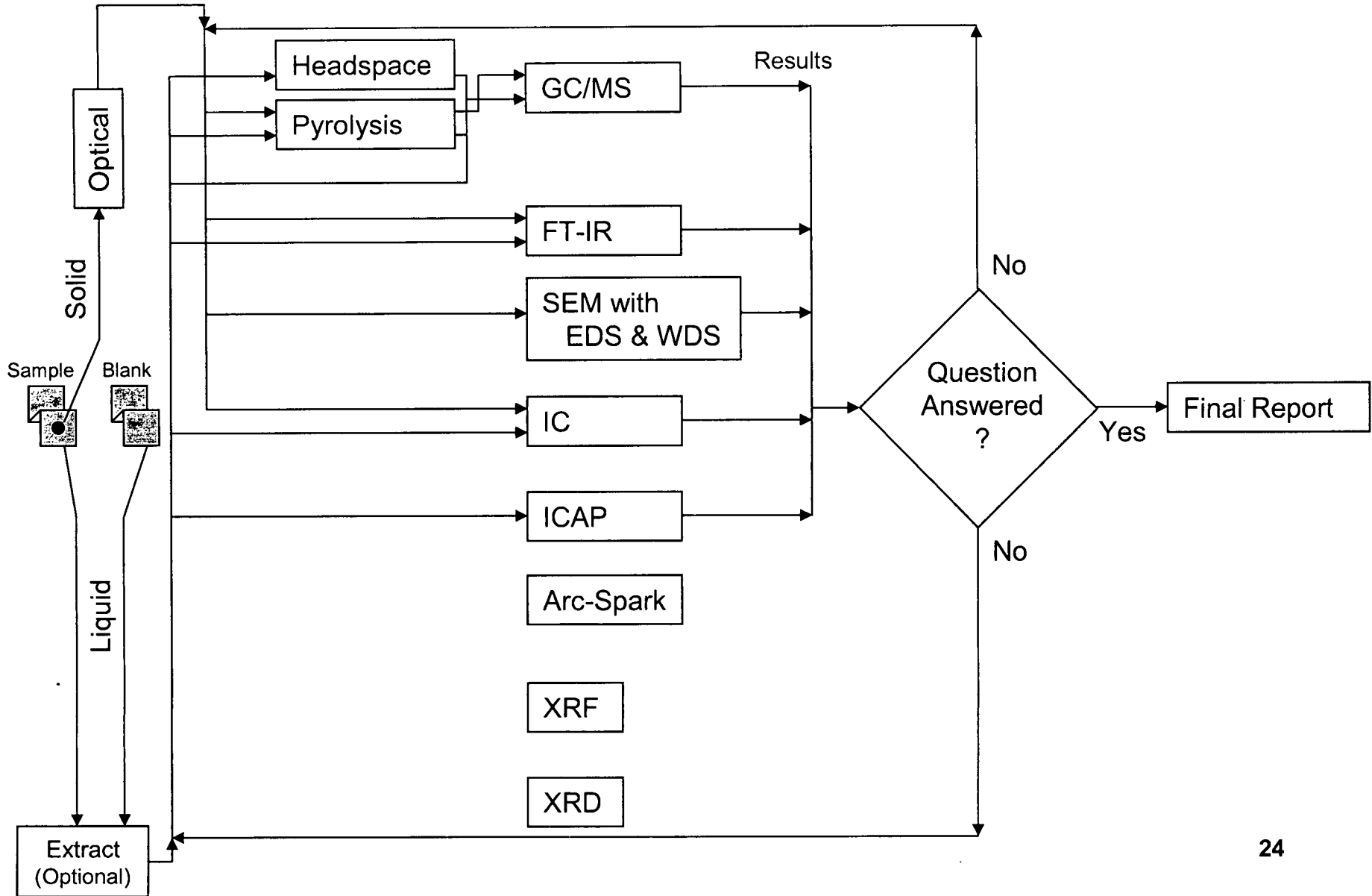



Gas Chromatography/Mass Spectrometry (GC/MS)

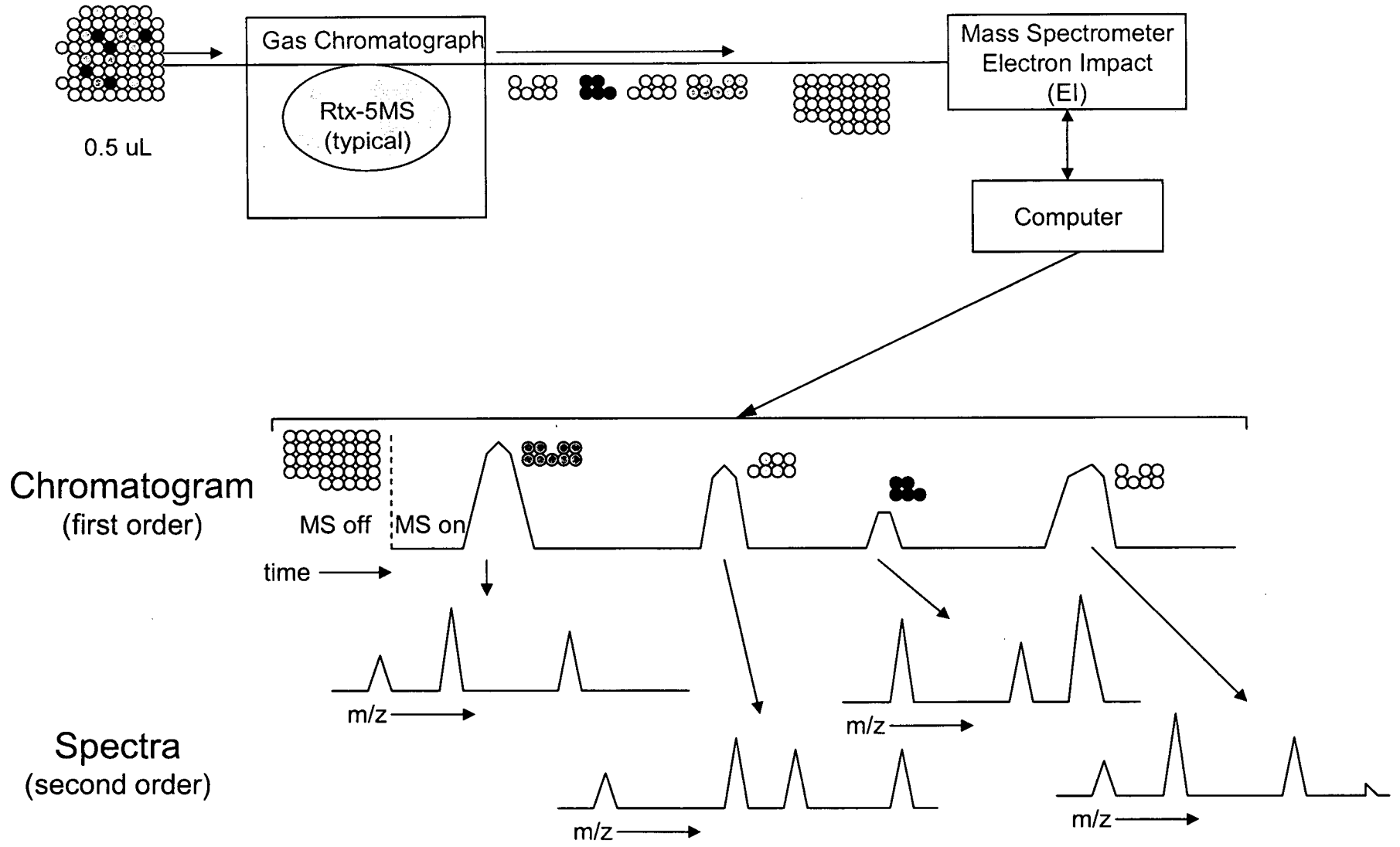



- **Gas Chromatograph coupled to a Mass Spectrometer**
 - Not separate units
 - Give two orders of verification
 - Time
 - Spectrum
- **Gas Chromatograph**
 - Separate compounds in time
 - Gas phase
- **Mass Spectrometer**
 - Obtain Structural information
 - Determine mass-to-charge (m/z) of fragments
 - Can obtain molecular weight information
- **Is a method to ID compounds**
- **Is a semi-quantitative method**



- **Catastrophic failure of 13,800 Volt feed line to the launch pads – main power supply**
- **Failure occurred at splice**
- **These analyses were to assist the investigation of the failure**
- **Analyses aimed at four different areas of concern**
 - Contamination
 - water intrusion
 - curing of materials
 - arc path determination



Contamination Analysis Example

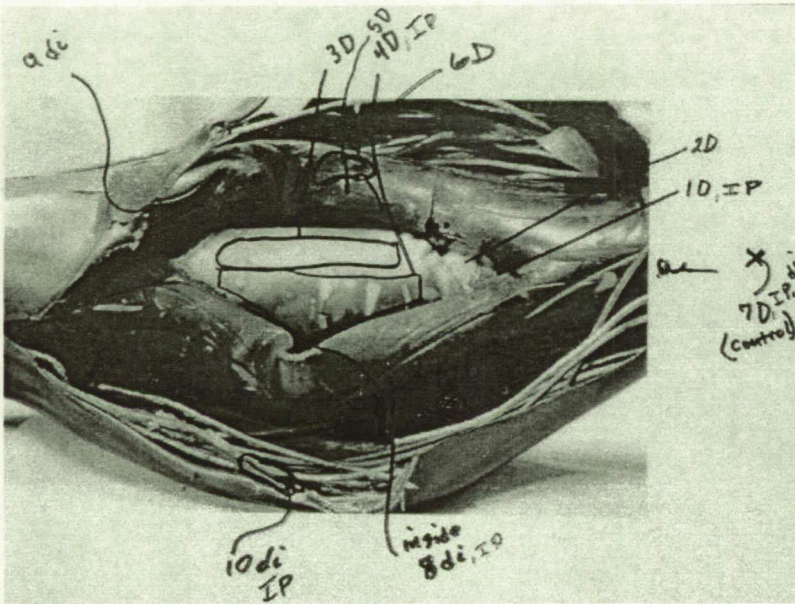

Figure 1.
Sample location of the Failed Cable Splice

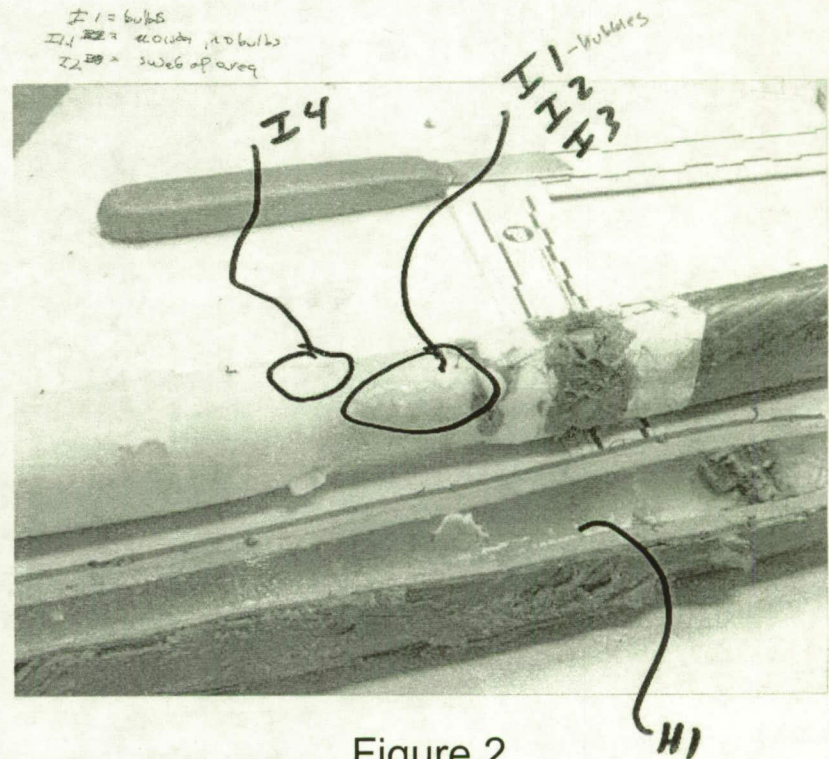

Figure 2.
Sample Locations of Non-Failed Wire



Table. Contamination Sources

Sample Location	Possible Contamination Sources							
	Semi-con	EPR	Yellow	Red	Rubber	Outer Sleeve	DCC	Glycerin
1 IP	X		X	X		X	X	X
4 IP	X		X	X	X	X	X	X
8 IP			X	X		X	X	X
10 IP		X	X	X	X	X		
I 1				X		X		X

X – indicates components from that source were detected

↑
Unknown Source

Table. Water Contamination

Sample Location	Water Present
B1	Yes
C1	Yes
D1	Yes
I2	No
G1	No

Unable to test failed splice – failed in water
Water Intrusion into outer sleeve but not inner sleeve



- **Curing of Material**
 - **Most of the sampled material were properly cured. However some of the red mastic showed indications of not being fully cured.**
- **Arc Path**
 - **There was an arc path along with metal deposits throughout the insulating area**
 - **Materials do not appear related to the tin plated copper splice**
- **Contamination**
 - **Analysis indicated presence of a contamination**
 - **The contamination was in an unusual physical state**



- **Contamination on International Space Station**
- **Extracted Wipe**
- **Could not see via FTIR**
 - Buried in background of wipe
 - Very low amount
- **Injected directly onto GC/MS**
- **After ID**
 - Obtained sample of possible contamination source
 - Not primary contamination source
 - Was able to see low amount of contamination from source

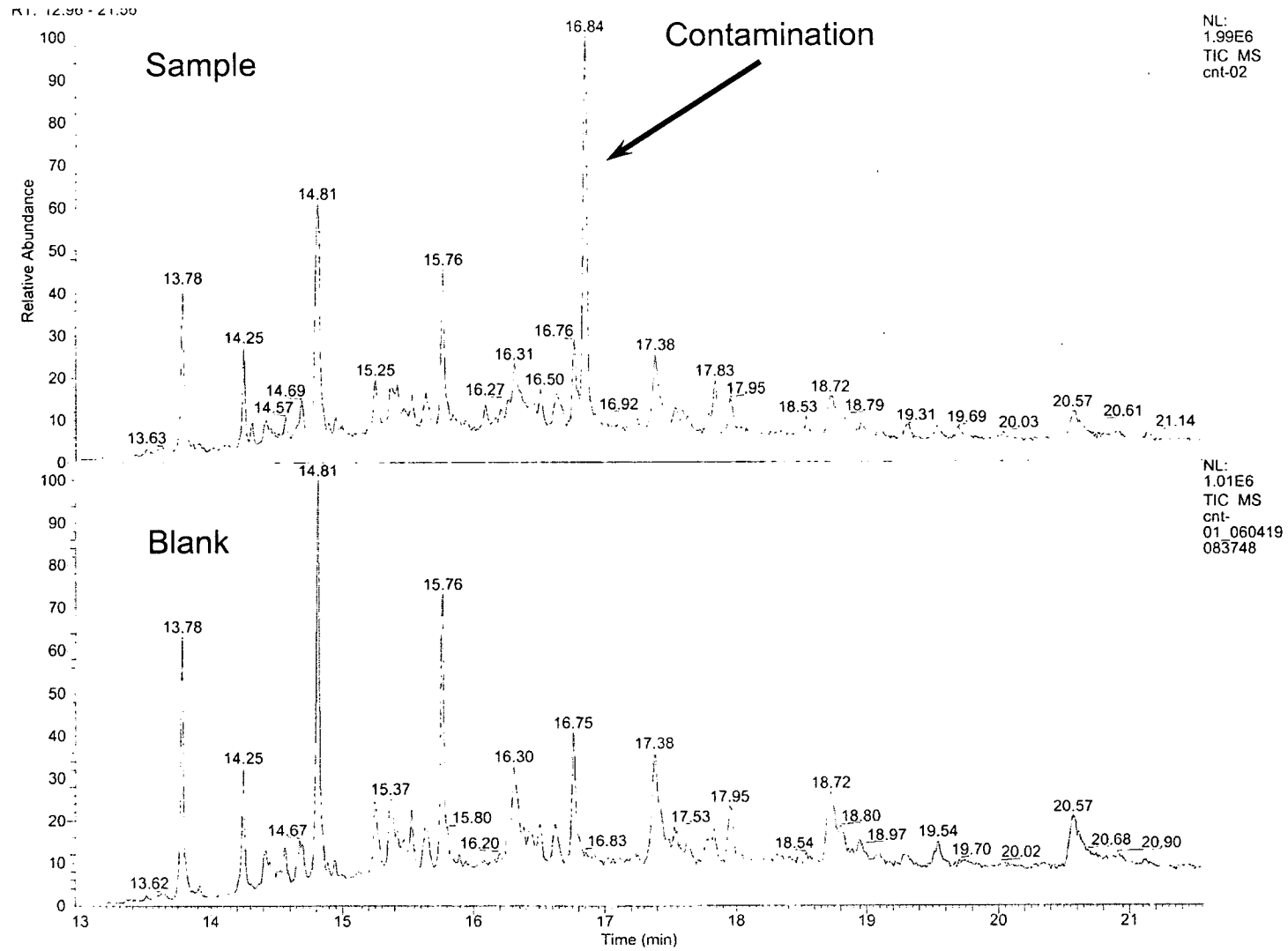

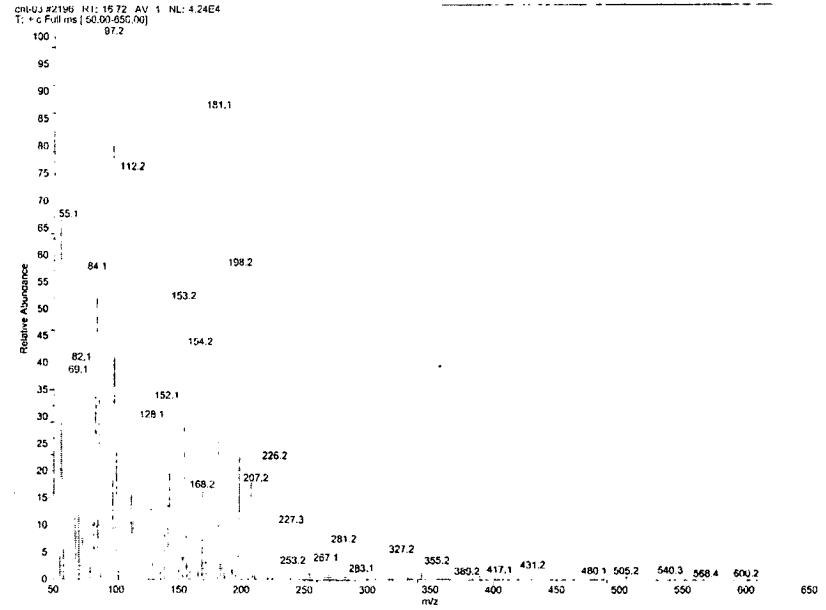
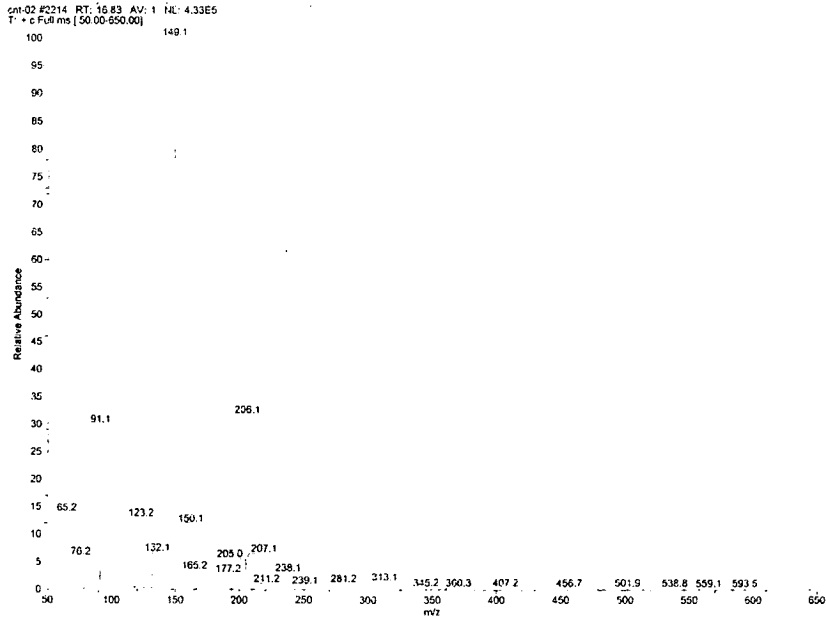

Contamination
(spectrum)

Possible Contamination
(spectrum)

Different Retention Times

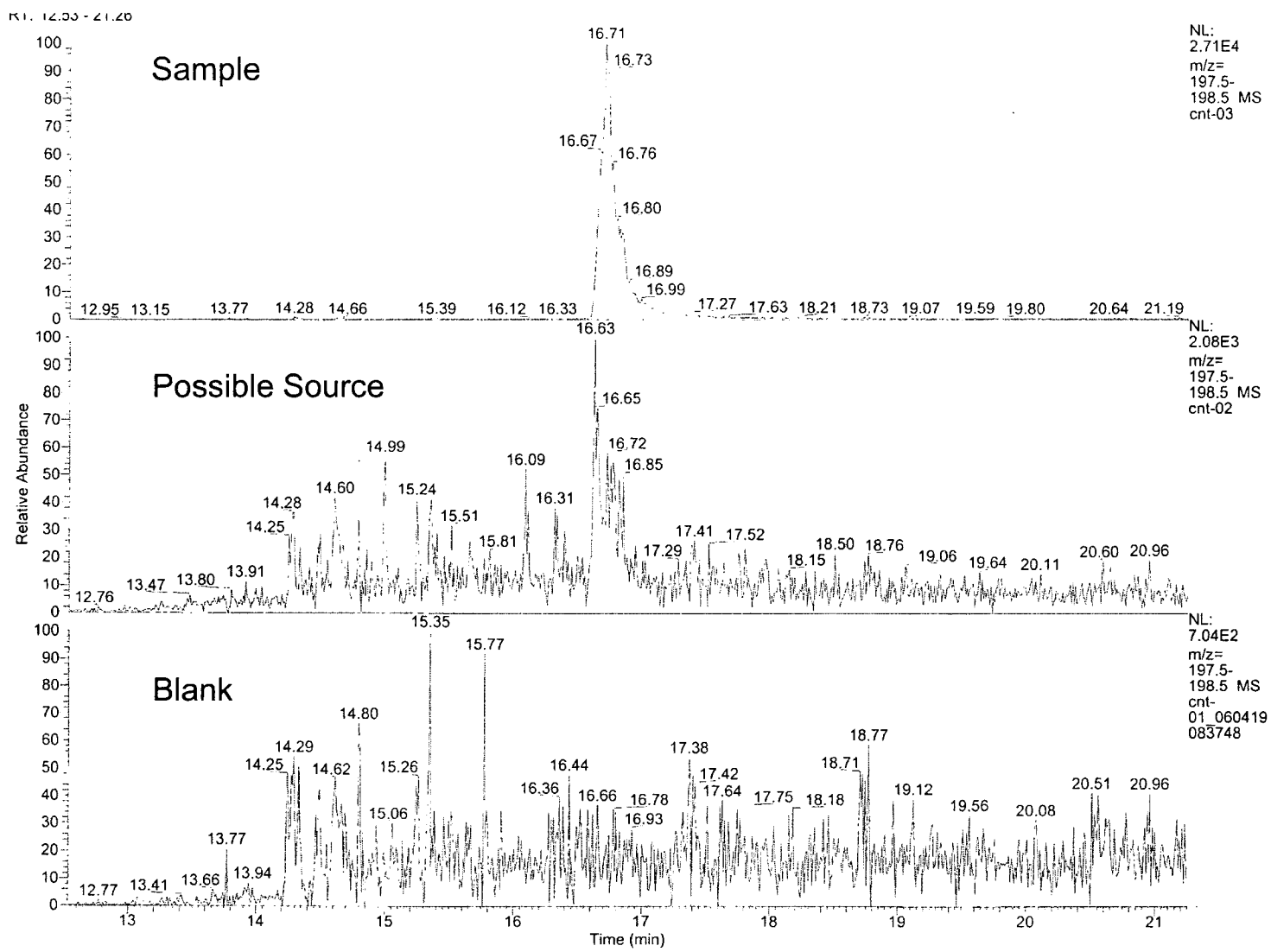



- **Obtained sample wanted to know if halogenated compound present**
 - If present how much
- **Direct Inject**
- **Very high level**
- **Used internal standard**



D:\Analysis\2006\0166\Oil-02
200 ppm TCLP B/N mix; 15 exposure; 1 min desorb
RT: 5.24 - 10.02

04/12/06 04:57:04 PM

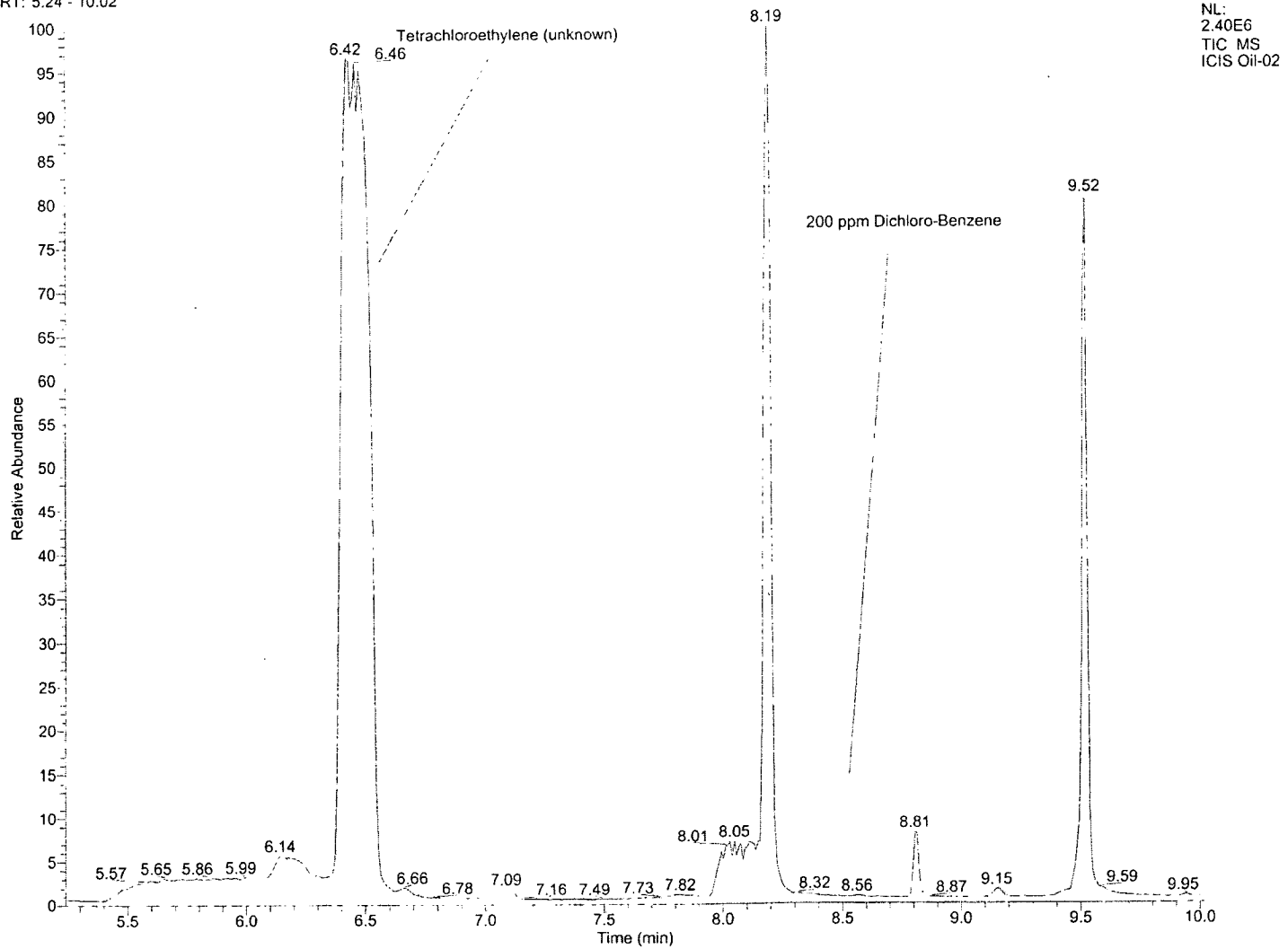



- **Contamination on Shuttle Orbiter**
- **Connector failing conductivity**
- **Possible source of contamination identified**
- **Cotton swab used to obtain sample**
- **Extract swabs – including control**
- **Could not see by FTIR**
- **Injected standard**
- **Was able to ID contamination on the swabs**

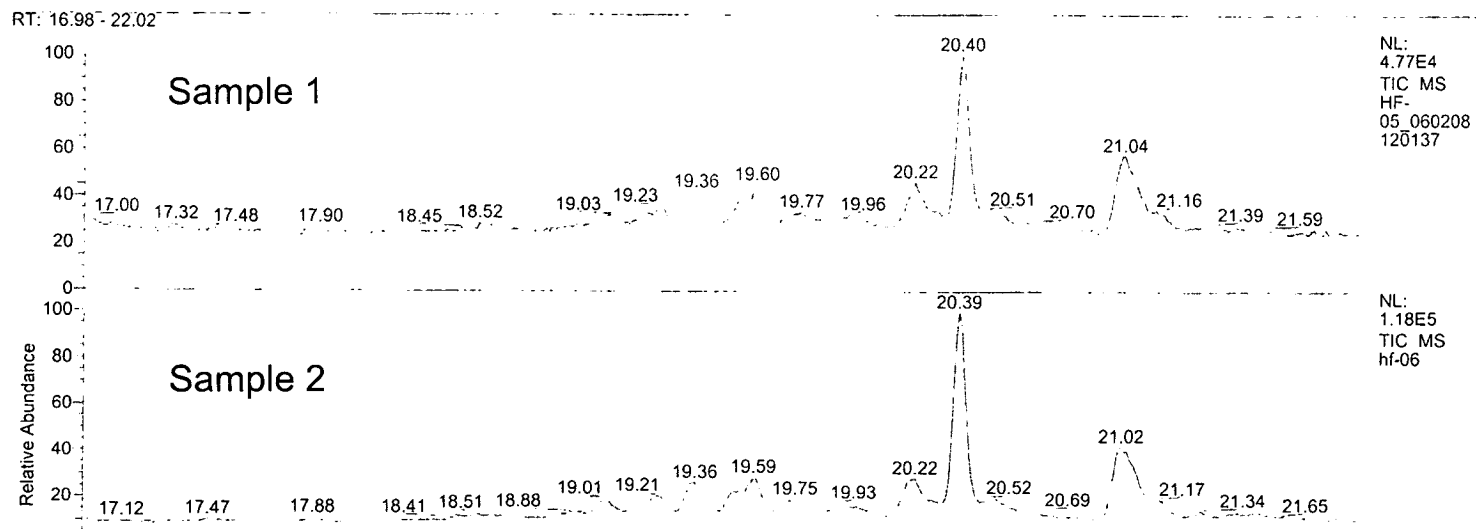



- **Excellent method for low concentration organics in complex matrix**
 - Can see low ppm or less
 - Separate out mixtures
- **Must be able to be brought into gas phase**
 - Evaporation
 - Degradation
 - Carried in gas stream
- **Can/must pull sample out of sampling device (wipe, swab)**
 - Extraction
 - Direct insertion probe
 - Pyrolysis (on order)
 - Headspace (on order)
- **Cautions when using**
 - Correct column selection (typically Rtx-5MS)
 - Temperature ramp on oven
 - Injector temperature
 - Mass range
- **Complex spectra**
 - Structural information (electron ionization - EI)
 - Library Matching
 - Compound determination
 - Molecular weight information (chemical ionization - CI)

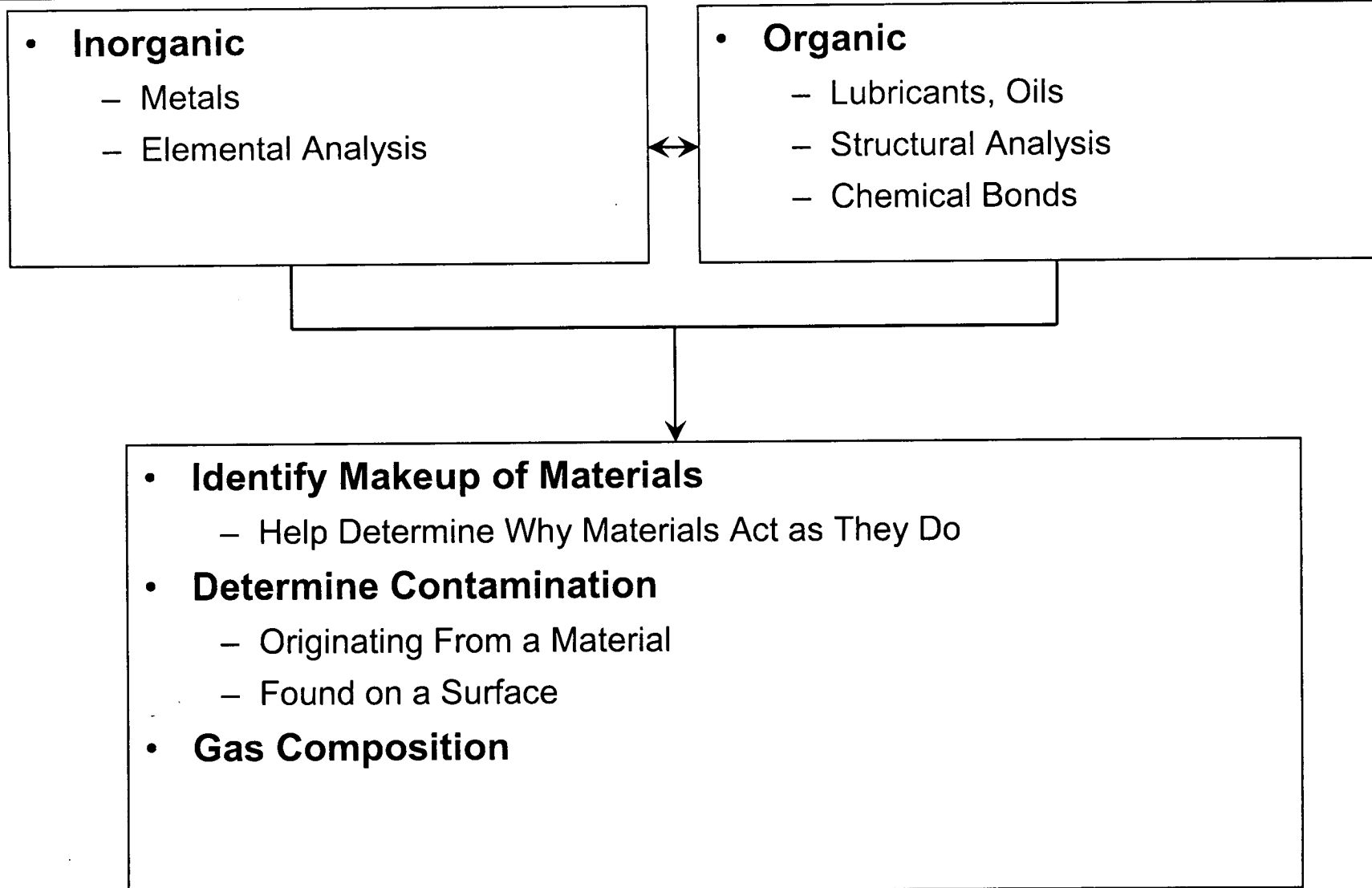

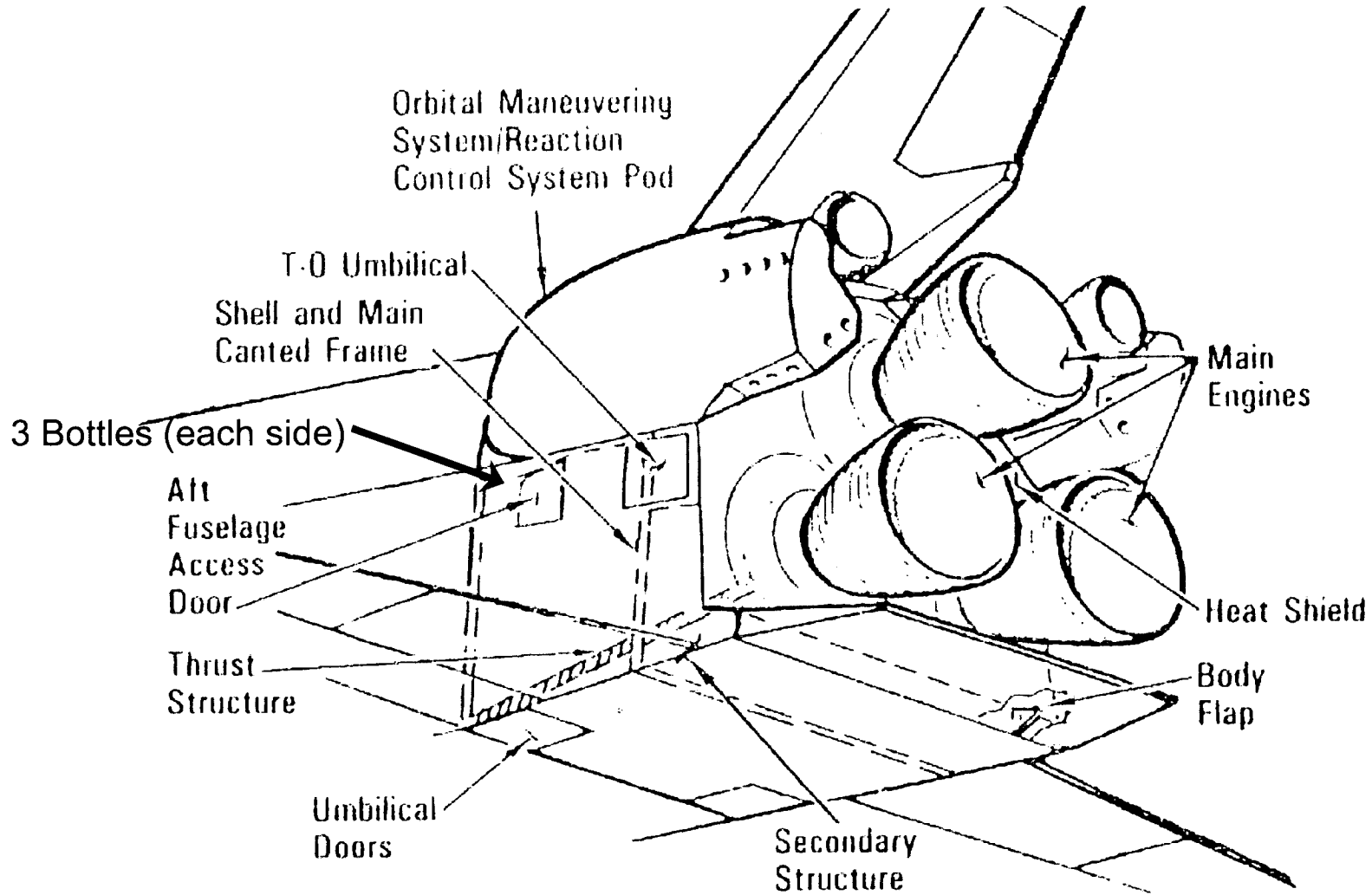

Aft Fuselage Structure



- **Six Evacuated Bottles in Aft of Orbiter During Ascent**
- **Opened at Specific Times During Ascent**
- **Bottles Removed After Mission**
- **All Pressures Sub Ambient**
 - 2 – 175 torr
- **Analyzed for Commodities of Interest for Main Engine**
 - H₂, He, O₂, Ar, CH₄, CO, CO₂
 - Detection Limits of 0.01 %
- **Used to Help Evaluate Main Engine Performance**



- **Utilizes GC/MS along with Custom Sample Inlet**
 - Detect Parts-Per-Million of Commodities
 - Monitor any Gas with Molecular Weight below 50 Daltons
 - Can Be Sub Ambient
 - Small Sample Volumes
 - Performs Shuttle Aft Gas Analysis

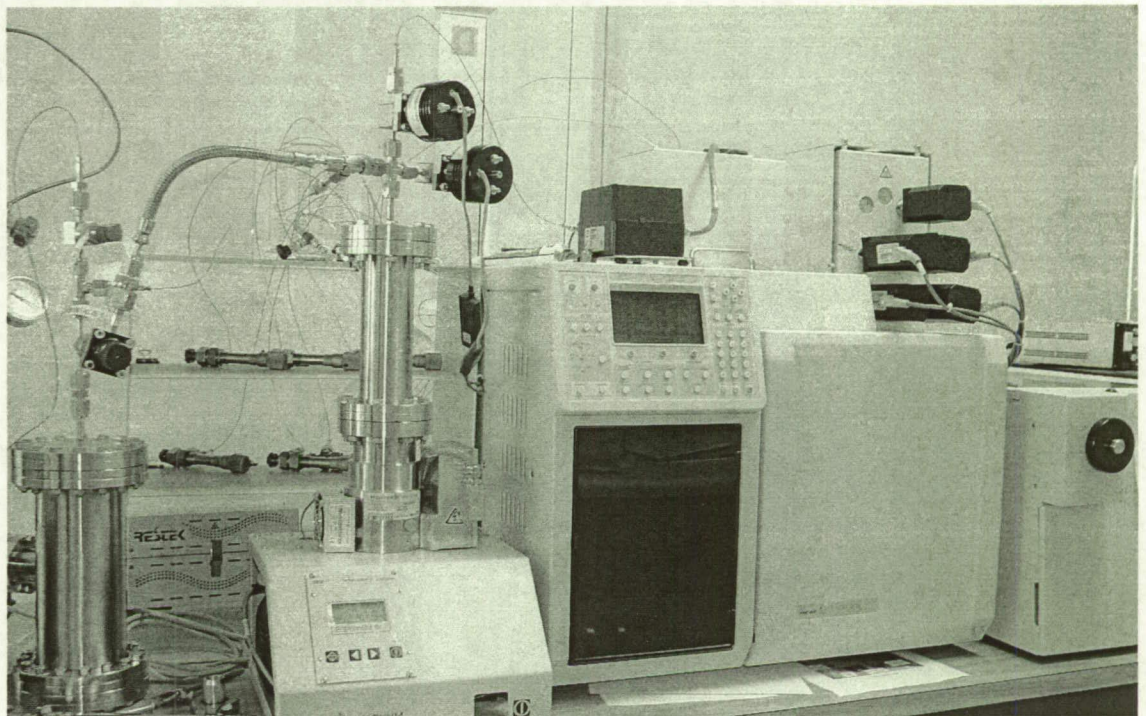



Sample Bottle Measured Oxygen Concentrations
With Redesigned Sample Bottle System (STS-71 thru STS-116)

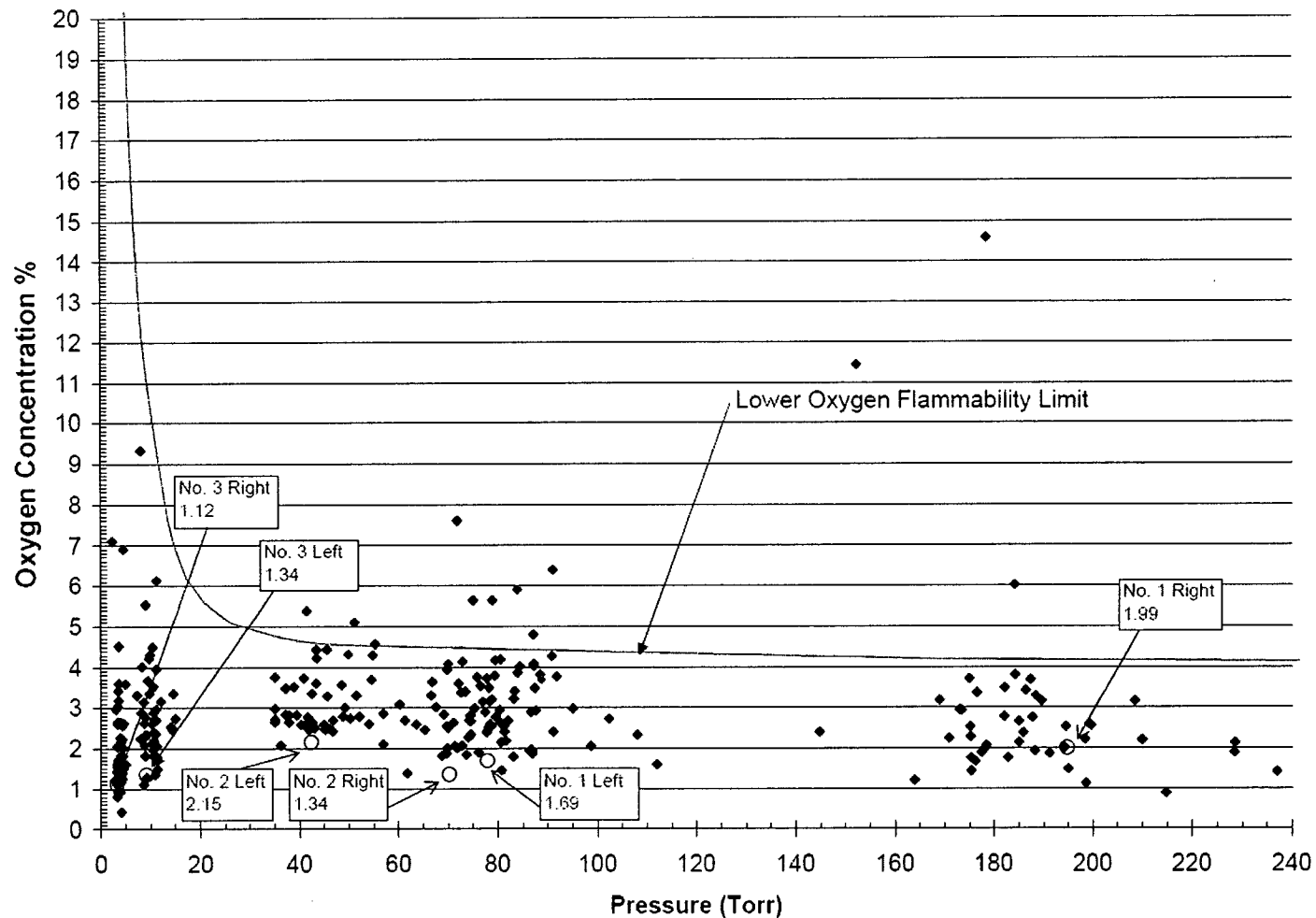



Chemistry is an invaluable tool in ensuring safe launches.



<http://www.nasa.gov/externalflash/apollo11/index1.html>

http://www.nasa.gov/mission_pages/constellation/multimedia/index.html