

NASA/TP—2012–217453



# Development and Analysis of Cold Trap for Use in Fission Surface Power-Primary Test Circuit

*T.M. Wolfe*

*Department of the Navy, Naval Sea Systems Command, Washington, DC*

*C.A. Dervan*

*Georgia Institute of Technology, Atlanta, Georgia*

*J.B. Pearson and T.J. Godfroy*

*Marshall Space Flight Center, Huntsville, Alabama*

---

*January 2012*

## The NASA STI Program...in Profile

Since its founding, NASA has been dedicated to the advancement of aeronautics and space science. The NASA Scientific and Technical Information (STI) Program Office plays a key part in helping NASA maintain this important role.

The NASA STI Program Office is operated by Langley Research Center, the lead center for NASA's scientific and technical information. The NASA STI Program Office provides access to the NASA STI Database, the largest collection of aeronautical and space science STI in the world. The Program Office is also NASA's institutional mechanism for disseminating the results of its research and development activities. These results are published by NASA in the NASA STI Report Series, which includes the following report types:

- **TECHNICAL PUBLICATION.** Reports of completed research or a major significant phase of research that present the results of NASA programs and include extensive data or theoretical analysis. Includes compilations of significant scientific and technical data and information deemed to be of continuing reference value. NASA's counterpart of peer-reviewed formal professional papers but has less stringent limitations on manuscript length and extent of graphic presentations.
- **TECHNICAL MEMORANDUM.** Scientific and technical findings that are preliminary or of specialized interest, e.g., quick release reports, working papers, and bibliographies that contain minimal annotation. Does not contain extensive analysis.
- **CONTRACTOR REPORT.** Scientific and technical findings by NASA-sponsored contractors and grantees.
- **CONFERENCE PUBLICATION.** Collected papers from scientific and technical conferences, symposia, seminars, or other meetings sponsored or cosponsored by NASA.
- **SPECIAL PUBLICATION.** Scientific, technical, or historical information from NASA programs, projects, and mission, often concerned with subjects having substantial public interest.
- **TECHNICAL TRANSLATION.** English-language translations of foreign scientific and technical material pertinent to NASA's mission.

Specialized services that complement the STI Program Office's diverse offerings include creating custom thesauri, building customized databases, organizing and publishing research results...even providing videos.

For more information about the NASA STI Program Office, see the following:

- Access the NASA STI program home page at <http://www.sti.nasa.gov>
- E-mail your question via the Internet to [help@sti.nasa.gov](mailto:help@sti.nasa.gov)
- Fax your question to the NASA STI Help Desk at 443-757-5803
- Phone the NASA STI Help Desk at 443-757-5802
- Write to:  
NASA STI Help Desk  
NASA Center for AeroSpace Information  
7115 Standard Drive  
Hanover, MD 21076-1320



# Development and Analysis of Cold Trap for Use in Fission Surface Power-Primary Test Circuit

*T.M. Wolfe*

*Department of the Navy, Naval Sea Systems Command, Washington, DC*

*C.A. Dervan*

*Georgia Institute of Technology, Atlanta, Georgia*

*J.B. Pearson and T.J. Godfroy*

*Marshall Space Flight Center, Huntsville, Alabama*

National Aeronautics and  
Space Administration

Marshall Space Flight Center • Huntsville, Alabama 35812

---

*January 2012*

## **Acknowledgments**

The authors from the Department of the Navy and Georgia Institute of Technology would like to thank Boise Pearson whose guidance and support has made this experience possible. Also, they would like to thank the following people who have been kind enough to take time from their projects and schedules to help them learn and grow, not only on this project but as professionals: Tom Godfroy, Bob Reid, Mike Schoenfeld, Anne Garber, and Kevin Berry. Finally, we would like to thank Mona Miller, Tina Haymaker, the WV Space Grant Consortium, and all others who have made this opportunity available.

## **TRADEMARKS**

Trade names and trademarks are used in this report for identification only. This usage does not constitute an official endorsement, either expressed or implied, by the National Aeronautics and Space Administration.

Available from:

NASA Center for AeroSpace Information  
7115 Standard Drive  
Hanover, MD 21076-1320  
443-757-5802

This report is also available in electronic form at  
<<https://www2.sti.nasa.gov/login/wt/>>



## TABLE OF CONTENTS

1. INTRODUCTION .....	1
2. PROBLEM STATEMENT .....	2
3. RESEARCH .....	4
3.1 Cold Trapping .....	4
3.2 Design Challenges .....	5
3.3 Initial Design .....	5
4. ANALYSIS .....	9
4.1 Sodium Potassium Properties .....	9
4.2 Power Analysis .....	11
4.3 System Cleanup Time Analysis .....	14
4.4 Pressure Drop Analysis .....	15
5. DESIGN .....	18
6. FUTURE WORK .....	21
7. CONCLUSION .....	22
REFERENCES .....	23

## LIST OF FIGURES

1.	FSP-PTC: (a) Corner view and (b) hosing down .....	3
2.	Enrico Fermi Atomic Power Plant forced circulation cold trap .....	4
3.	Cold trap designs: (a) Sodium reactor experiment cold trap with coolant coil and (b) design with coolant jacket .....	6
4.	Cold trap: (a) Boiling coolant with external economizer and (b) HNPF with internal economizer .....	7
5.	FSP-PTC with primary components labeled .....	9
6.	Cold trap control volume showing temperature and mass flow rate relationships .....	10
7.	Cold trap control volume showing temperature and mass flow rate relationships .....	12
8.	Total power required by core versus percentage of flow rate through cold trap at different cold trap locations in FSP-PTC system loop .....	13
9.	Power loss through cold trap versus percentage of flow rate through cold trap at varying system operating temperatures .....	13
10.	Schematic of cold trap control volume definition used to derive first order oxygen concentration time differentiable equation .....	14
11.	FSP-PTC system purification versus time at various mass flow rates through cold trap .....	15
12.	Measured pressure drop across cold trap using varied mesh diameters and $L/D$ ratios as a function of percentage flow through the cold trap .....	17
13.	Schematic of cold trap with components labeled .....	18
14.	Current cold trap design views: (a) Isometric view, (b) side view, (c) close-up of top view, and (d) isometric cutaway view .....	20

## LIST OF TABLES

1.	NaK properties .....	10
2.	Oxygen solubility in NaK and Na investigation data .....	10
3.	FSP-PTC loop data used in analysis .....	11
4.	Wick structure permeability .....	16

## LIST OF ACRONYMS AND SYMBOLS

EFF-TF	Early Flight Fission-Test Facility
EM	electromagnetic
FSP-PTC	Fission Surface Power-Primary Test Circuit
HNPF	Hallam Nuclear Power Facility
HX	heat exchanger
K	potassium
Na	sodium
NaK	sodium potassium alloy
NaK-78	alkali metal (78% potassium and 22% sodium by weight)

## NOMENCLATURE

$A_w$	open cross-sectional area of the cold trap ( $m^2$ )
$C_0$	initial concentration of oxygen in the NaK (ppm)
$C_{CT}$	NaK oxygen concentration exiting the cold trap (ppm)
$C_L$	NaK oxygen concentration in the loop (ppm)
$C_p$	specific heat capacity of NaK ( $J\ kg^{-1}\ K^{-1}$ )
$D$	diameter (in)
$L$	length (in)
$L_{eff}$	effective length over which the $\Delta P$ is taken (m)
$m_L$	mass of NaK in the loop (kg)
$\dot{m}$	nominal mass flow rate of NaK ( $kg\ s^{-1}$ ) through FSP-PTC
$\dot{m}_{CT}$	mass flow rate through the cold trap along bypass line
$P$	pressure (psi)
$\dot{Q}$	power (W)
$\dot{Q}_{CT}$	power through the cold trap (W)
$T$	temperature (K, °C)
$T_{CT}$	cold trap operating temperature
$T_{in}$	inlet temperature
$T_{out}$	outlet temperature
$t$	time (s)
$V$	total volume of NaK in the FSP-PTC ( $m^3$ )
$V_{ct}$	cold trap control volume
$\dot{V}$	volumetric flow rate through the cold trap ( $m^3\ s^{-1}$ )
$\varepsilon$	effectiveness
$\kappa$	permeability of mesh ( $m^2$ )
$\mu_l$	viscosity of NaK ( $kg\ m^{-1}\ s^{-1}$ )
$\rho_l$	density of NaK ( $kg\ m^{-3}$ )



## TECHNICAL PUBLICATION

### **DEVELOPMENT AND ANALYSIS OF COLD TRAP FOR USE IN FISSION SURFACE POWER-PRIMARY TEST CIRCUIT**

#### **1. INTRODUCTION**

The Early Flight Fission-Test Facility (EFF-TF) is a creation of the NASA Marshall Space Flight Center Propulsion Research and Technology Branch Nuclear Propulsion Group. Its purpose is to recreate and simulate nuclear reactor capabilities using non-nuclear methodologies. One focus of the EFF-TF is the testing of a pumped alkali metal (NaK-78) flow circuit, the Fission Surface Power-Primary Test Circuit (FSP-PTC).<sup>1-3</sup> The sodium potassium alloy (NaK) in the FSP-PTC has on occasion become contaminated with oxygen, which can cause corrosion and plugging of the test circuit. This Technical Publication centers around the design and analysis of a forced circulation cold trap to remove the oxygen from eutectic NaK-78.

## 2. PROBLEM STATEMENT

Eutectic NaK-78, which is an alkali metal alloy consisting of 78% potassium (K) and 22% sodium (Na) by weight, has often been used as a coolant in nuclear reactors.<sup>1</sup> Because of its low melting point and high thermal conductivity, NaK acts as an excellent working fluid to use in the FSP-PTC, shown in figure 1. However, oxygen impurities can be found in NaK that may cause increased corrosion and possible blockage of flow passages via oxide precipitation that can cause operating problems within a pumped NaK system.<sup>4</sup> Considering the effects these oxygen impurities can have, it was decided to incorporate a method to remove and contain the majority of oxygen present in the FSP-PTC by means of a cold trap.

A cold trap works by running the NaK flow through a cold part of the system. The cold trap temperature is lower than the system temperature to cause oxides to precipitate out and be trapped within the cold trap, not allowing oxide circulation through the system.<sup>5</sup> This process acts as an efficient means of removing oxygen from the bulk NaK flow.

During the cleanup/take-down phase of the FSP-PTC when all NaK is removed from the system, impurities were found in the NaK mixture. These impurities, mainly various forms of Na and K oxides, were a result of oxygen being trapped within the closed system. Impurities in the NaK mixture, even at concentrations <30 ppm, can cause significant corrosion and reduced performance.<sup>6</sup> In addition, oxygen impurities can cause blockages of flow via oxide precipitation, which can further enhance operating problems within the NaK system.<sup>4</sup> To prevent these negative effects on the system, a method for purification had to be developed that could be used in the system to purify the NaK. It was decided to design a cold trap for use in the FSP-PTC to isolate oxides present in the NaK loop. The goal of the cold trap is to have the capability to clean the NaK with a theoretical oxygen concentration of between 13 and 1,000 ppm.





(a)



(b)

Figure 1. FSP-PTC: (a) Corner view and (b) hosing down.

### 3. RESEARCH

Cold trapping is one of the oldest forms of alkali metal purification. A cold trap works by running the NaK flow through a system that induces a cold point lower than the system temperature where oxides precipitate and are trapped, inhibiting oxide circulation through the system. The cold trapping process can be performed either by allowing the contaminants to diffuse to the cold point, or by circulating the fluid through a cold region.<sup>5</sup>

#### 3.1 Cold Trapping

There are two types of cold traps—natural circulation and forced circulation. Forced circulation cold traps operate along a bypass line as opposed to the main line of the system and work by circulating the flow through a cold region to reach a specified oxidation temperature. Natural circulation cold traps usually operate in-line and work by running the main flow through a cold point where a specified oxidation temperature can be reached. Natural circulation cold traps are often used for smaller laboratory-scale experiments, whereas forced circulation cold traps are for larger systems.<sup>5</sup> Due to these differences, a forced circulation cold trap was selected as the method of choice for the FSP-PTC. A forced circulation cold trap is shown in figure 2.

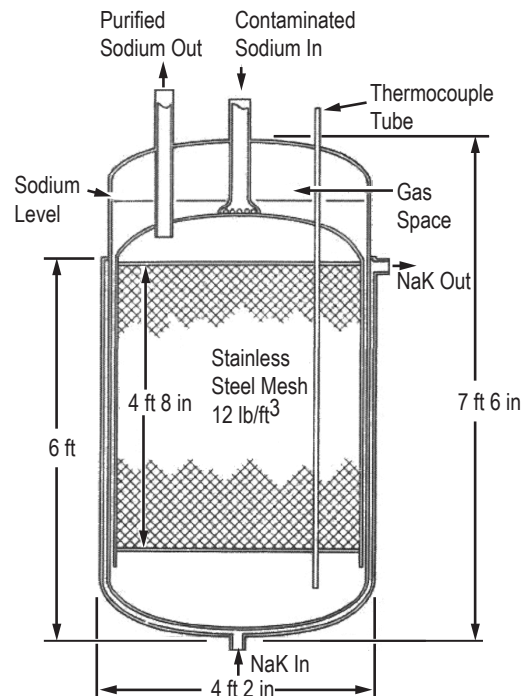

Figure 2. Enrico Fermi Atomic Power Plant forced circulation cold trap.

Forced circulation cold traps are generally used in large heat transfer systems. This particular method of cold trapping operates along a bypass line as opposed to the main line in the system. This allows drawing of a small portion of the main flow into the cold trap without considerably affecting the rest of the system.

Most forced circulation cold traps consist of an economizer, which acts as a regenerative heat exchanger (HX), a crystalline tank for collecting the oxide precipitates, and a coolant system. Although it is not required, stainless steel wire or mesh, called packing, is often used in cold traps to increase the surface area onto which crystallization of the oxide can occur.<sup>5</sup>

### **3.2 Design Challenges**

Several factors have to be considered to design a cold trap to effectively remove oxide contaminants from the NaK fluid. The first challenge is to design a trap that prevents plugging. Plugging makes the cold trap inoperable by blocking the flow of NaK into the trap.

In addition, the cooling load imposed by the cold trap must take into consideration the maximum power capacity of the simulated core within the system, so that the core is not overloaded. The maximum capacity of the core used in the FSP-PTC is 30 kW.

Another concern that must be resolved is the pressure drop that is created across the cold trap. Large pressure drops are problematic, as they can cause a decrease in flow across the cold trap or could potentially create a ‘back flow’ in which the bypass flow travels in the opposite direction of the main flow. The change in flow would then cause further problems, such as affecting the cleanup time necessary for the cold trap and the required power needed to operate it.

To ensure that the maximum amount of oxide is being filtered out of the NaK as it flows through the cold trap, a sufficient residence time was determined. Previous work has shown that increasing the residence time to 5 min greatly increased the effectiveness of the cold trap to remove oxygen; however, the effectiveness was not sufficiently affected by an increase from 5 to 10 min.<sup>7</sup> Research has shown that a 5-min residence time is generally accepted for cold trap designs.

### **3.3 Initial Design**

A design was developed to remove oxygen from the FSP-PTC. This design has been developed to prevent and resolve the various design challenges from oxide plugging to pressure drops.

#### **3.3.1 Coolant System**

To reach a specified cold trap temperature, a coolant system must be incorporated into the cold trap design. The coolant design is based largely on the type of coolant used to achieve the cold trap’s cooling region temperature. Both liquid and gaseous cooling mediums were considered for internal cooling. External cooling is also possible through the implementation of cooling fins, but was deemed impractical in a vacuum environment like the one the FSP-PTC will be operated in during normal operation. In the past, many cold traps used liquid coolants such as tetralin, toluene, and

Dowtherm™. Although these coolants exhibit excellent heat transfer qualities, they are less safe than other coolant methods and are not compatible in direct contact with NaK because they are organic compounds. Although the coolant is not intended to come in direct contact with the NaK used in the FSP-PTC, the system is experimental and failures can occur with test equipment. Nitrogen was ultimately selected as the coolant for use in the FSP-PTC cold trap. This was due to the availability of nitrogen in the EFF-TF facility, compatibility with NaK, and success in the past with other cold trap designs such as the Hallam Nuclear Power Facility (HNPF) cold trap.<sup>7</sup> Figure 3(a) and (b) show a cooling coil and a cooling jacket, respectively.

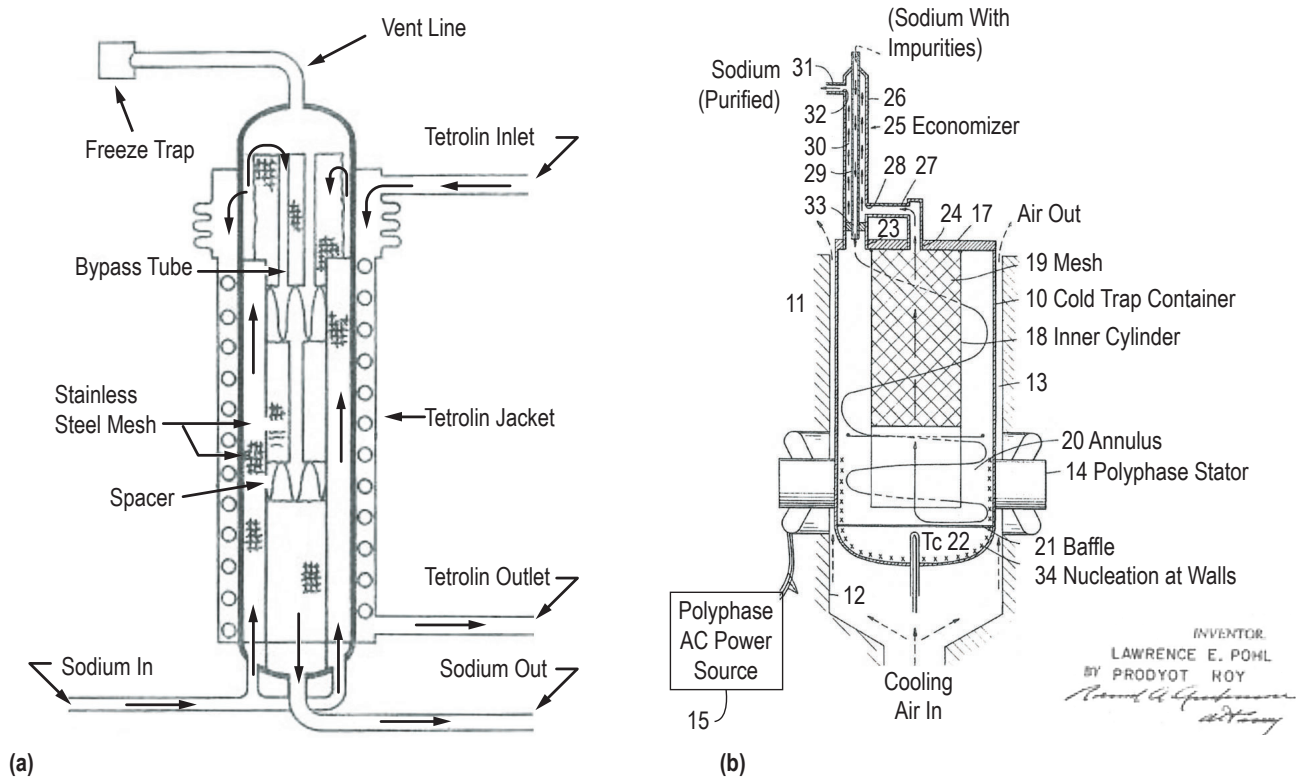

Figure 3. Cold trap designs: (a) Sodium reactor experiment cold trap with coolant coil<sup>7</sup> and (b) design with coolant jacket.<sup>8</sup>

With the coolant selection in mind, it was determined that a cooling jacket placed around the main cold trap assembly would be the best cooling method. This jacket would include an inlet at the bottom of the cold trap to ensure a cooler region at the bottom of the cold trap, acting in counter-flow to the NaK entering the cold trap. Two methods were determined to generate the proper cold trap temperature through the use of the nitrogen coolant—control of the flow rate of nitrogen and control of the incoming nitrogen temperature through the use of an electric immersion heater element. Finally, a thermocouple port included in the cold trap design will allow the monitoring of the cold trap operating temperature.



### 3.3.2 Economizer

One issue with the implementation of a cold trap in a system loop is the large drop in temperature of the bypass working fluid, and its effect on the heat balance of the circuit. To reduce the overall impact of the cold trap in the FSP-PTC, a decision was made to include an economizer to the cold trap design. Economizers help to aid cooling upon entry and heating upon exit of the cold trap, recover enthalpy, and improve efficiency. Previously used external and internal economizer designs were researched and are shown in figure 4(a) and (b). External economizers are placed outside of the main cold trap and are often arranged in a counterflow heat exchanger configuration. However, the main problem with an external economizer is its tendency to plug. This is caused by early oxidation of the working fluid in the economizer, causing oxidation buildup and eventually plugging.<sup>7</sup> An internal economizer does not have this problem because the flow does not have to be contained as in an external economizer. The basic design of an internal economizer for use in a cold trap consists of a coil used on the outflow running out of the top of the cold trap while the working fluid runs freely outside of the coil. Considering the internal economizers free flow design, this type of economizer was selected for incorporation into the cold trap design for the FSP-PTC.

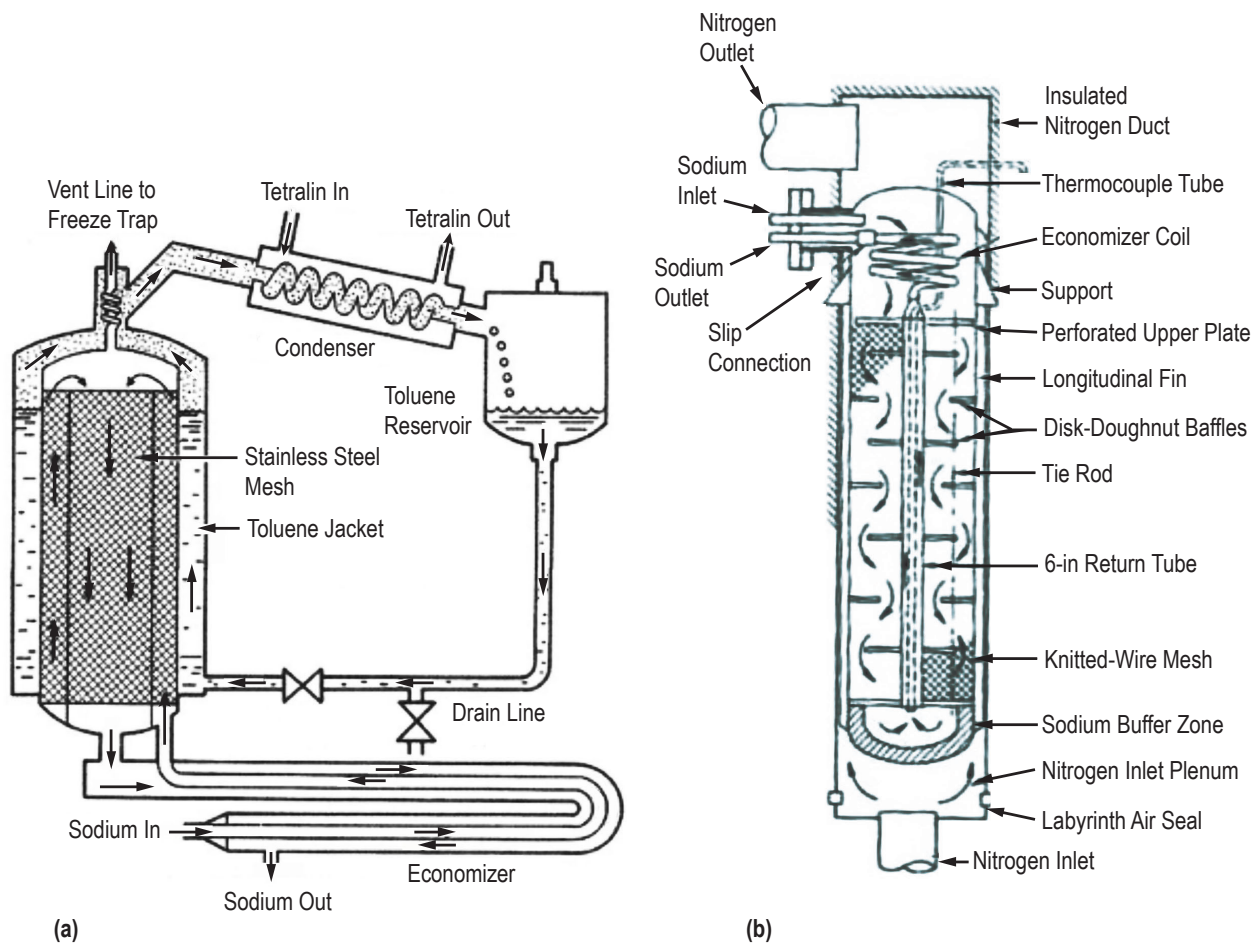

Figure 4. Cold trap: (a) Boiling coolant with external economizer and (b) HNPF with internal economizer.

### 3.3.3 Packing

Although it is not absolutely necessary for cold trap operation, stainless steel mesh packing was included in the design of the cold trap. Packing creates increased surface area for the precipitating oxide to cling to in addition to the walls of the crystalline tank. It also creates a more uniform deposition of oxides, which could help to minimize pressure drops across the cold trap.<sup>9</sup> Packless cold traps have been tested and proven to work, but present operational problems presumed to be caused by plugging from the inability of a packless trap to trap the oxide.<sup>7</sup> To avoid plugging of the cold trap, packing was used for the initial design of the cold trap used in the FSP-PTC. There are several types of packed trap filters that have been used including knitted steel wire, steel wire mesh, screen, and Raschig rings. From previous studies, stainless steel wire mesh was determined to provide best results for oxide deposition and has been chosen for the FSP-PTC cold trap design.<sup>7</sup>

### 3.3.4 Baffles

Disk-doughnut baffles are often used in the design of cold traps due to their effectiveness at aiding in the filtration of oxides. Baffles prevent straight-line channeling, forcing the NaK to flow through a larger portion of the mesh. In essence, baffles help to disrupt the natural flow of NaK through the cold trap. By doing this, they allow for a more uniform cooling of the flow, which helps to precipitate out more oxide than would otherwise be achievable without the use of baffles.<sup>7</sup>

The implementation of baffles into a cold trap has also been found to reduce the need for larger length ( $L$ )-to-diameter ( $D$ ) ratios. It has recently been proposed that baffles could efficiently increase the residence time of the NaK within the cold trap. This could prove beneficial for pumped-flow systems that have space limitations and cannot achieve the desired residence time of 5 min with their current designs.

## 4. ANALYSIS

The FSP-PTC consists of several main components including a heater core, HX, electromagnetic (EM) pump, and a flow meter (fig. 5). To effectively design the cold trap, an analysis of the impact the cold trap would have on the overall system was completed.

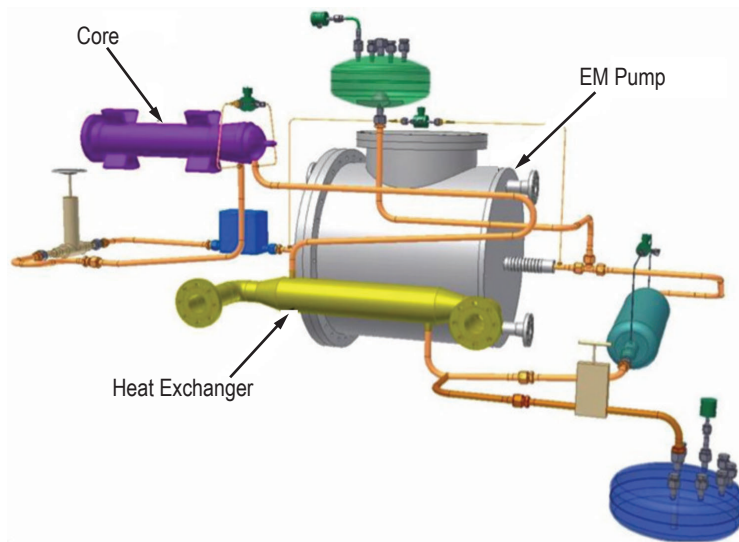

Figure 5. FSP-PTC with primary components labeled.

### 4.1 Sodium Potassium Properties

To determine the cold trap operating temperature, oxygen solubility versus temperature data was analyzed for both NaK and Na curves as seen in figure 6. Table 1 shows the NaK properties.

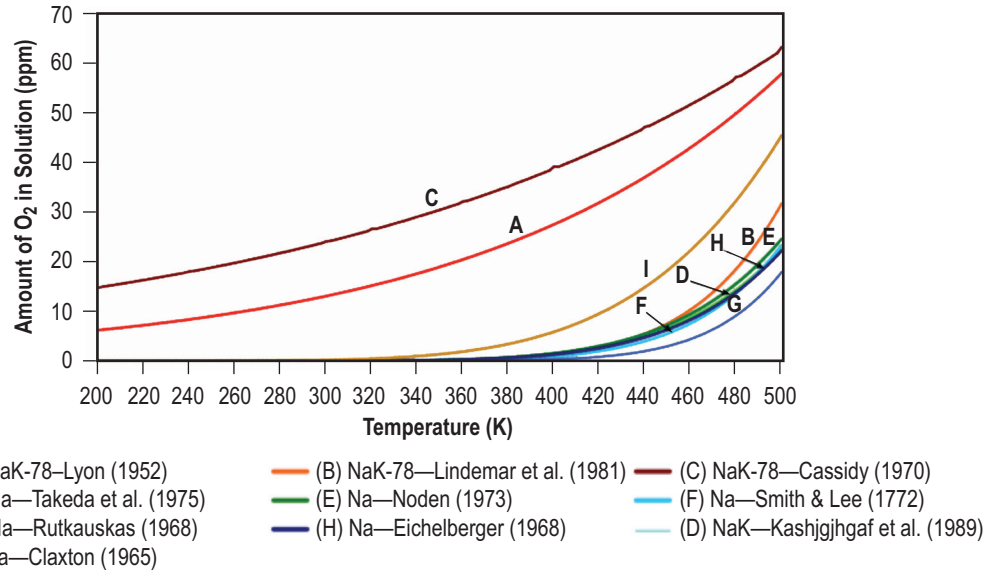

Figure 6. Cold trap control volume showing temperature and mass flow rate relationships.<sup>4,10,11</sup>

Table 1. NaK properties.<sup>10</sup>

Viscosity	$1.599 \times 10^{-4} \text{ kg m}^{-1} \text{ s}^{-1}$
Density	$738.78 \text{ kg m}^{-3}$
Specific heat	$874.07 \text{ J kg}^{-1} \text{ K}^{-1}$

Table 2 shows the investigator, equation, valid temperature range, and number of data points in the curve fitting for the investigation of oxygen solubility in NaK and Na.

Table 2. Oxygen solubility in NaK and Na investigation data.

Liquid Metal	Investigator	Number of Data	Temperature Range (K)	Equation
NaK-78	Lindemar et al. (1981)	39	363~483	$\log_{10}S=7.09-2795/T$
	Lyon (1952)	9	370~800	$S=1.4013\exp(T/134.5)$
NaK	Cassidy (1970)	N/A	N/A	N/A
Na	Takeda et al. (1975)	37	423~323	$\log_{10}S=6.118-2383/T$
	Rutkauskas (1968)	52	398~573	$\log_{10}S=8.25-3499/T$
	Noden (1973)	217	387~828	$\log_{10}S=6.1579-2384.2/T$
	Smith & Lee (1972)	51	398~518	$\log_{10}S=7.023-2828/T$
	Eichelberger (1968)	107	398~828	$\log_{10}S=6.239-2447/T$
	Claxton (1965)	88	383~828	$\log_{10}S=5.21-1777/T$



## 4.2 Power Analysis

An analysis of the optimal cold trap location within the FSP-PTC was performed to determine the impact of the cold trap on the overall system and to determine inlet boundary conditions for the cold trap that would have an impact on the specific design of the cold trap. The first analysis consisted of examining temperature data around the FSP-PTC loop at normal operation with a flow rate of 13.18 gpm (table 3).<sup>2</sup> Three locations were considered for placement of the cold trap, although the conditions for placement can be applied to other locations in the loop. The three locations considered are in parallel with the core, in parallel with the EM pump, and in parallel with the HX.

Table 3. FSP-PTC loop data used in analysis.<sup>2</sup>

Applied pump power	1,124 W
Average pump temperature	334.2 °C
HX inlet temperature, NaK	345 °C
Core inlet temperature	332.9 °C
NaK flow rate	13.18 gpm
System volume	30 lb

One driving decision in cold trap location is the amount of power required by the core for the addition of the cold trap at each location. For each location, the power required by the cold trap for operation was determined using equation (1):

$$\dot{Q} = \dot{m}C_p \Delta T \quad , \quad (1)$$

where

$\dot{Q}$  = power through each analyzed component of the FSP-PTC

$\dot{m}$  = total system mass flow rate through each component

$C_p$  = specific heat of NaK-78

$\Delta T$  = difference in temperature at the outlet and inlet of each component.

By varying the percentage of mass flow rate, the power through the cold trap could be simulated for different bypass mass flow rates ranging from 1% to 100% of the total system mass flow rate at each location in the loop. Because the cold trap operates by reducing the temperature, an internal coil economizer is used to reduce the impact of the total system temperature drop. The temperature and mass flow rate relationship of the control volume is shown in figure 7. By examining data from the HNPf cold trap that uses a similar style economizer, a curve fit of the economizer effectiveness was generated at varying mass flow rates and the corresponding effectiveness for each mass flow rate could then be interpolated.<sup>9</sup> With the effectiveness determined, the outlet temperature could be estimated from the following relationship:

$$\varepsilon = \frac{T_{\text{out}} - T_{\text{CT}}}{T_{\text{in}} - T_{\text{CT}}} \quad , \quad (2)$$

where

- $\varepsilon$  = economizer effectiveness
- $T_{in}$  = cold trap inlet temperature
- $T_{out}$  = cold trap outlet temperature
- $T_{CT}$  = cold trap operating temperature.

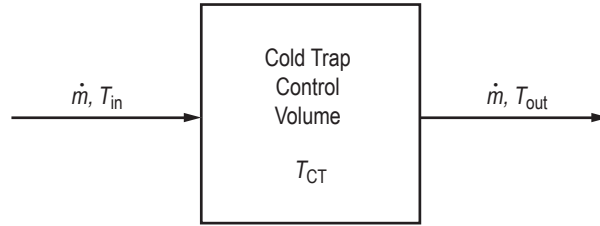

Figure 7. Cold trap control volume showing temperature and mass flow rate relationships.

The corresponding cold trap operating temperature to achieve 12.5 ppm oxygen solubility was estimated to be around 370 K. With these data, the outlet temperature could be determined using equation (2). By incorporating the economizer effectiveness and temperature drop through the cold trap, the cold trap power could be determined using the following relationship:

$$\dot{Q}_{CT} = \dot{m}_{bypass} C_p \Delta T \varepsilon , \quad (3)$$

where

- $\dot{Q}_{CT}$  = power through the cold trap
- $\dot{m}_{bypass}$  = mass flow rate through the cold trap along the bypass line as a percentage of the total system mass flow rate
- $\Delta T$  = difference in temperature at the outlet and inlet of the cold trap.

In this relationship, the cold trap power is determined at varying percentages of total system mass flow rate. Finally, with all FSP-PTC component power determined at varying percentages of total system mass flow rate through the cold trap, the system could be looked at as a whole and the required core power for different cold trap locations could be determined as seen in figure 8.

As shown, when the cold trap is around the HX, the required core power is at its minimum. Because the core can only operate at a maximum of 30 kW, the percentage of mass flow rate through the cold trap could not exceed 95%. It was requested that the required core power not exceed 10 kW, which narrowed the cold trap bypass percentage to under 25%.

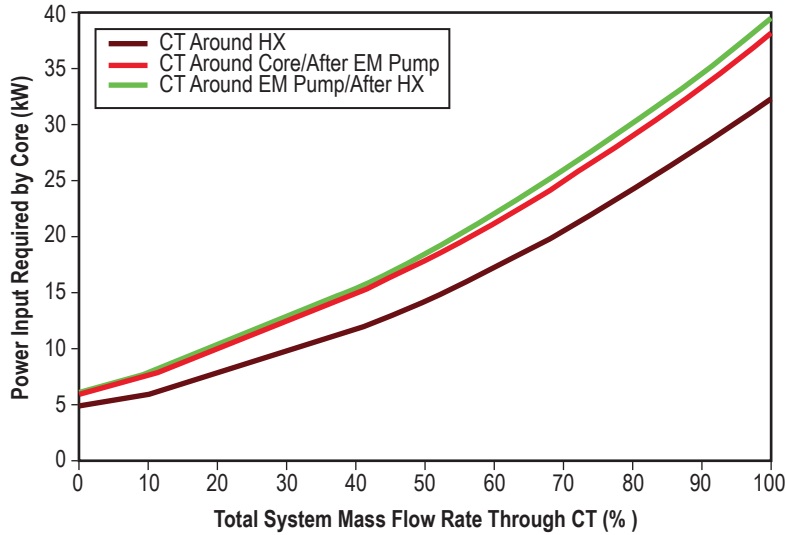

Figure 8. Total power required by core versus percentage of flow rate through cold trap at different cold trap locations in FSP-PTC system loop.

The next design step was to choose a location for the cold trap and test different system operating temperatures including the average operating temperature of the location selected, a minimum operating temperature of 473 K, and a maximum operating temperature of 805 K. Using these conditions, a closer look at the power through the cold trap was examined as seen in figure 9. Although the HX provided the lowest required core power, lower mass flow rates showed that the difference in required power to be similar. With this in mind, it was decided to place the cold trap around the EM pump which provides the cold trap with a large  $\Delta T$  and provides the coolest location in the system loop, which will consequently require less cooling of the NaK in the cold trap.

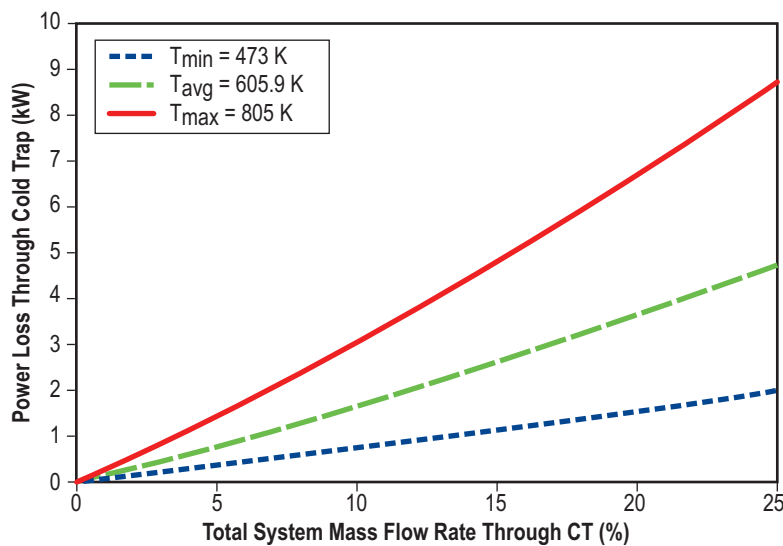

Figure 9. Power loss through cold trap versus percentage of flow rate through cold trap at varying system operating temperatures.

From figure 9, the decision to keep the percentage of total mass flow rate through the cold trap under 5% was made due to the strong rise in cold trap power as the percentage of total system mass flow rate increased.

### 4.3 System Cleanup Time Analysis

The time required for system cleanup was calculated to ensure the cold trap could clean the NaK in the FSP-PTC in a reasonable amount of time (preferably within a few hours). The cleanup time was determined by treating the loop as a control volume and deriving a first order differential equation with the given boundary conditions.

The NaK loop is represented by a control volume (fig. 10) with a branch flow through the cold trap. The loop has a total NaK mass of  $m_L$ , and an instantaneous oxygen concentration of  $C_L(t)$ . Exiting the control volume is the flow rate through the cold trap,  $\dot{m}_{CT}$  at the oxygen concentration of the loop. Returning to the control volume is the mass flow rate through the cold trap at the oxygen concentration of the cold trap,  $C_{CT}$ . This leads to the following relationship:

$$m_L \frac{dC_L}{dt} = \dot{m}_{CT} C_{CT} - \dot{m}_{CT} C_L \quad (4)$$

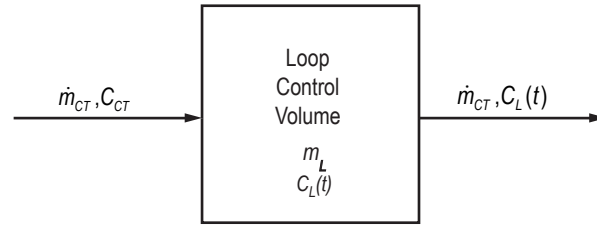

Figure 10. Schematic of cold trap control volume definition used to derive first order oxygen concentration time differentiable equation.

This relationship can be rearranged, integrated with using the initial time of zero and the initial loop concentration of  $C_0$ :

$$m_L \int_{C_0}^{C_L} \frac{dC_L}{C_{CT} - C_L} = \int_0^t \dot{m}_{CT} dt \quad (5)$$

and solved for  $C_L$ :

$$C_L = C_0 e^{-\frac{\dot{m}_{CT} t}{m_L}} + C_{CT} \left( 1 - e^{-\frac{\dot{m}_{CT} t}{m_L}} \right) \quad (6)$$

With this equation, the oxygen concentration of the loop can be plotted versus time at various mass flow rates through the cold trap. As the concentration approaches  $C_{CT}$  asymptotically over time, it is convenient to plot  $C_L - C_{CT}$  on a log scale.

As a bounding case, equation (6) is used to examine the loop at 805 K, with the oxygen concentration of the loop at saturation (556 ppm), and a cold trap temperature of 300 K, with oxygen concentration leaving the cold trap of 13 ppm. These results are plotted at various  $\dot{m}_{CT}$  in figure 11.

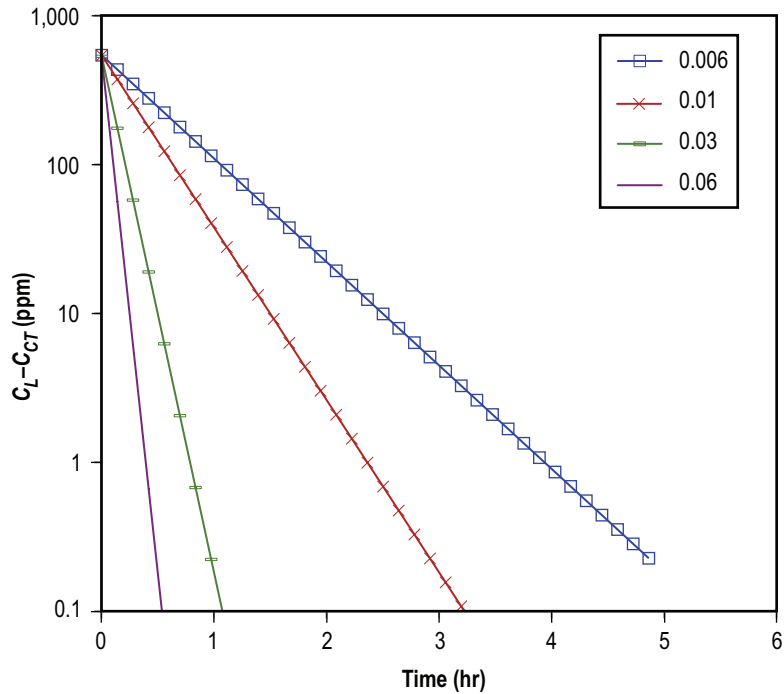

Figure 11. FSP-PTC system purification versus time at various mass flow rates through cold trap.

The nominal mass flow rate of the FSP-PTC is 0.61 kg/s, so the cold trap mass flow rates in figure 11 represent a range of 1% to 10% of the total mass flow rate diverted through the cold trap. In the preceding section, a limit was set of 5% of the nominal flow rate, or 0.03 kg/s. A system cleanup time of 1–4 hr is possible, if the goal is to achieve  $C_L - C_{CT} = 1$ .

#### 4.4 Pressure Drop Analysis

As stated earlier, one of the key design challenges in the creation of a cold trap is to implement a method or technique to effectively reduce the pressure drop. A large pressure drop can cause one of two effects: it can either stop the flow of NaK through the cold trap, or it can create a ‘back flow’ that would cause the flow through the cold trap to travel in the opposite direction of the main

flow. The use of packing in the design of the cold trap helps to decrease the pressure drop by allowing for a more uniform deposition of oxide.

In addition to the use of packing, the  $L/D$  ratio of the cold trap also impacts the pressure drop. According to research, previous cold trap designs have typically been limited to a 5:1  $L/D$  ratio. Although there is no set standard  $L/D$  ratio for cold traps, proper sizing for optimum performance is necessary. A small  $L/D$  ratio does result in lower pressure drops across the cold trap, however it also causes negative effects on performance. As the  $L/D$  ratio decreases, the ability of the coolant jacket to effectively cool the NaK decreases. This results in less oxide precipitating out of the fluid, which in turn requires the purification time to increase.

To effectively quantify the pressure drop for varying  $L/D$  relationships, Darcy’s law is used. Darcy’s law is represented in equation (7):

$$\Delta P = \frac{\mu_l L_{eff} \dot{m}_{CT}}{\kappa \rho_l A_w} , \tag{7}$$

where

- $\mu_l$  = viscosity of NaK
- $L_{eff}$  = length over which the  $\Delta P$  is taken
- $\dot{m}_{CT}$  = mass flow rate of NaK flowing through the cold trap
- $\kappa$  = permeability of mesh
- $\rho_l$  = density of the NaK fluid
- $A_w$  = open cross-sectional area of the cold trap.

Table 4 shows the wick structure permeability.<sup>12</sup>

Table 4. Wick structure permeability.

Stainless Steel Fibers	Permeability (m <sup>2</sup> )
33 $\mu$ m diameter	$2 \times 10^{-10}$
75 $\mu$ m diameter	$1.16 \times 10^{-9}$

Two separate  $L/D$  ratios were used to analyze the effects that they had on the pressure drop—ratios 3:1 and 5:1 with a set diameter of 1.5 and 2.5 in, respectively. However, to do the calculations, the permeability of the mesh needed to be known. Two different thicknesses of mesh were chosen with diameters of 33 and 75  $\mu$ m. Figure 12 represents the data calculated from the two different  $L/D$  ratios for the two types of mesh.

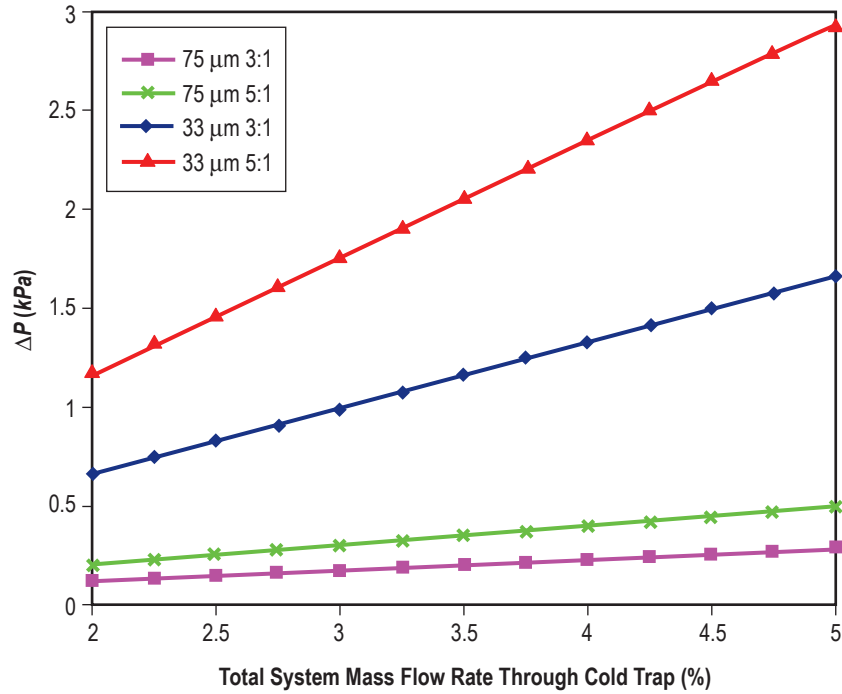

Figure 12. Measured pressure drop across cold trap using varied mesh diameters and  $L/D$  ratios as a function of percentage flow through the cold trap.

Figure 12 provides valuable insight into the effects of mesh sizing and  $L/D$  ratios on the pressure drop across the cold trap. As expected, the 5:1  $L/D$  ratio creates a larger pressure drop as opposed to the 3:1 ratio. The 33- $\mu\text{m}$  mesh also provides a larger  $\Delta P$ , as expected, because its open area is less than that of the 75  $\mu\text{m}$ . Proper mesh sizing and overall sizing of the cold trap are necessary to eliminate the effects of the baffles on the  $\Delta P$ . Because the baffles help to disrupt the natural flow of NaK through the cold trap, they also tend to cause an increase in the pressure drop. Altogether, it has been determined that the maximum estimated  $\Delta P$  across the cold trap is  $\approx 0.45$  psi.

## 5. DESIGN

The current configuration of the cold trap design consists of the following components: a nitrogen cooling jacket, the outer shell of the cold trap, an inlet port, an economizer coil, a stainless steel mesh, baffles, an outlet line running to the economizer, and a drain line and valve. The details of this design can be seen in figure 13.

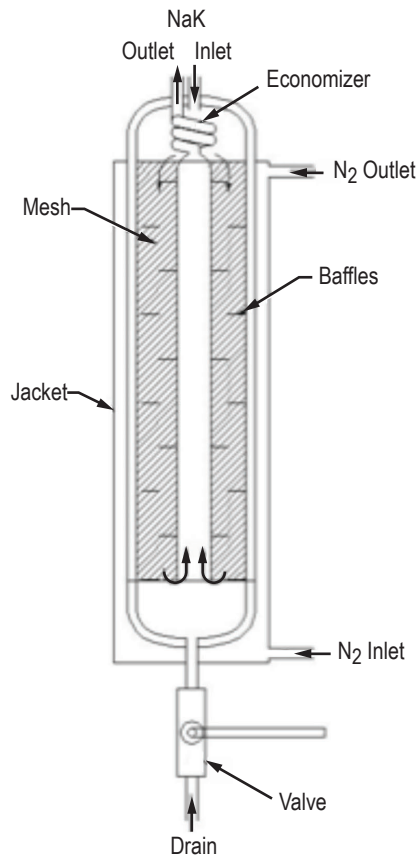

Figure 13. Schematic of cold trap with components labeled.

After completing analysis on the cold trap, a range of 2% to 5% of the total system mass flow rate was determined to provide sufficient cold trap performance as it relates to power consumption and system cleanup time. The current sizing of the overall cold trap was based on the smallest possible size that would yield between a 3:1 and 5:1  $L/D$  ratio: a height of  $\approx 11$  in and a diameter of 2.875 in. This design has  $\approx 1$  L of total volume. The maximum volume of the system should not exceed 2 L to avoid resizing of the FSP-PTC NaK reservoirs. The total mass of NaK in the FSP-PTC is 30 lb, which corresponds to  $\approx 7$  mL of total oxide that will be trapped at one time in the cold trap. With the total cold trap volume of nearly 1 L, this allows many runs of the FSP-PTC before the cold



trap will need to be cleaned or replaced. The current method for cleaning is to heat the oxide to a liquid state and drain through the bottom of the cold trap. Next, steam cleaning the cold trap can cause a reaction of the NaK within the cold trap. This method, however, is not foolproof and may require additional efforts to ensure total cold trap cleanup or total replacement of the cold trap system.

The actual construction of the cold trap will consist mainly of stainless steel material, including a 2.5-in pipe with American Standard of Mechanical Engineers flanged and dished heads or pipe caps on the ends for the actual cold trap body, quarter-inch line for the inlet, drain, outlet, and economizer, stainless steel mesh and baffles, and a nitrogen jacket, which has not yet been fully designed. Connections are to be made using butt-welded fittings to ensure NaK cannot be entrapped in fittings. Figure 14(a)–(d) shows three-dimensional renderings of the current cold trap design.

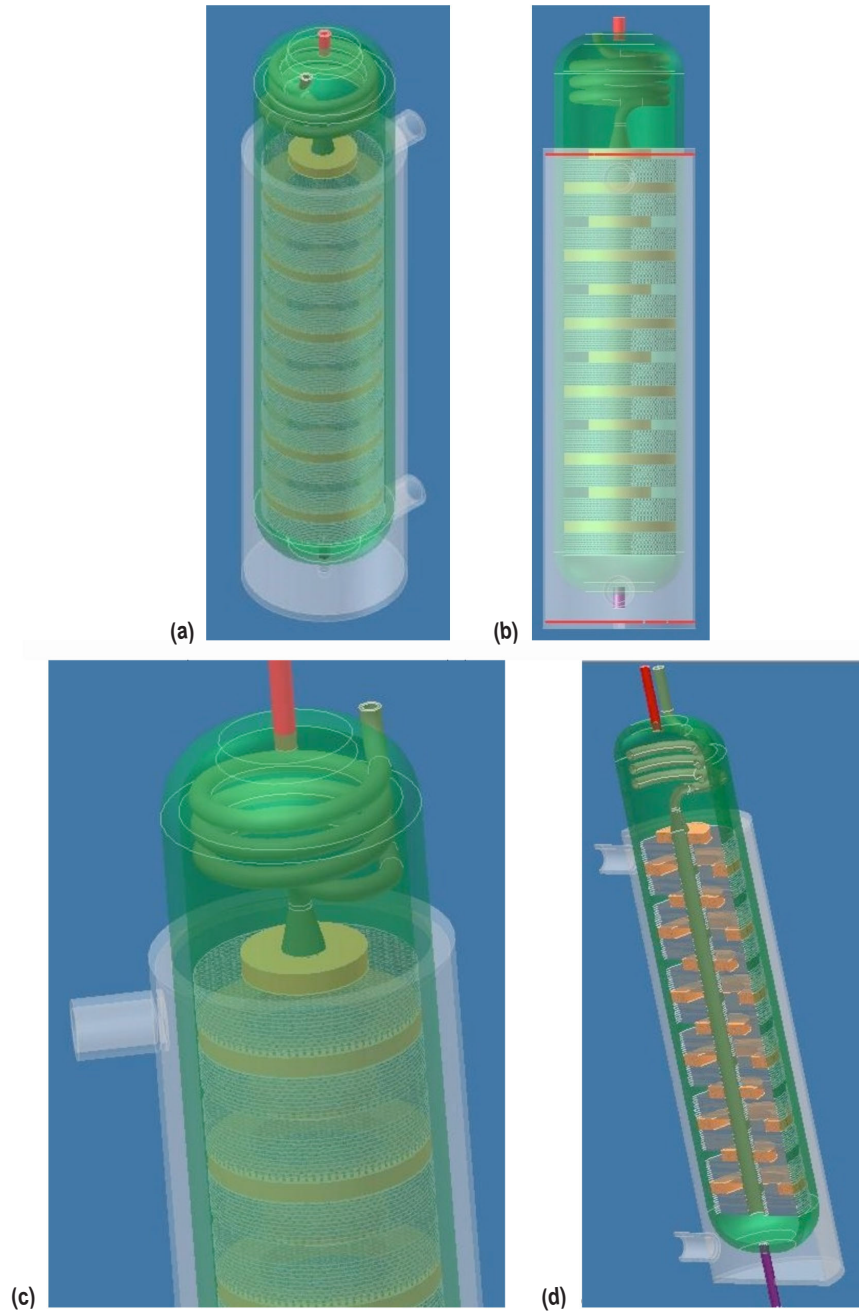

Figure 14. Current cold trap design views: (a) Isometric view, (b) side view, (c) close-up of top view, and (d) isometric cutaway view.

## 6. FUTURE WORK

For the FSP-PTC, more details need to be examined before the design is finalized. The current cold trap design needs to be increased in overall size to allow a larger residence time and increased economizer coil size from  $\frac{1}{4}$ - to  $\frac{3}{8}$ -in tubing. By increasing the size of the economizer, the possibility of blockage is reduced. Additional solubility data for NaK at lower temperatures (approximately 150–500 K) also need to be researched or determined experimentally to more accurately determine the optimal cold trap operating temperature and to refine system cleanup time calculations based on these data. These data can have an effect on required power and system cleanup time calculations. These data could be achieved with the addition of a plugging line in parallel with the cold trap, which can also act to determine if the cold trap is not operating effectively.<sup>13</sup>

Packing for the cold trap also needs to be examined in further detail. If a stainless steel mesh is selected, the size of the mesh must still be determined. It may also be possible to use other forms of packing such as a honeycomb filter.

Another component to consider is the nitrogen jacket used for cooling. Sizing of the inlet/outlet ports and spacing between the cold trap wall and the inner jacket wall needs to be completed. A thermocouple port needs to be incorporated into the cold trap design to determine the operating temperature of the cold trap so that the nitrogen flow rate or temperature can be varied using the nitrogen valve or in-line heater element yet to be chosen for final design.

Heat transfer calculations must be performed on the economizer and coolant jacket to determine how to optimize and properly design the coolant jacket and determine the theoretical efficiency of the economizer more accurately. Performing heat transfer calculations of the nitrogen's ability to cool the NaK through the cold trap wall and internal wire mesh is vital in the overall sizing of the nitrogen jacket and to determine the temperature the nitrogen will operate. Calculations of the effects on the temperature of the NaK internal to the economizer from the external hot flow are needed to determine how effective the economizer will be at reheating the outlet flow.

Finally, a suitable method for cleanup needs to be decided upon. Previous cold trap designs have had problems cleaning the NaK and oxide from the cold trap completely, even after reheating, draining, and steam cleaning, which is the current preferred cleanup method. One possible option is to use a flange that could be used to take apart the cold trap, although it would most likely have to contain a custom-made stainless steel seal that could be a difficult and potentially hazardous option.

## **7. CONCLUSION**

The primary objective of this project was to design and implement a purification technique, more specifically, a forced circulated cold trap, into the FSP-PTC to effectively remove oxygen from the NaK fluid. Several key components of the cold trap were analyzed and researched to best satisfy the demands of the Propulsion Research and Technology Branch. Although future design analysis is necessary to further understand the heat transfer capabilities of the cold trap, an initial design that removes oxygen from the FSP-PTC has been achieved.

## REFERENCES

1. Garber, A.E.; and Godfroy, T.J.: "Assembly, Analysis and Fill of the Stainless Steel NaK-Cooled Circuit (SNaKC)," NASA Marshall Space Flight Center Internal Document, ER24-06-SNAKC, 2006.
2. Garber, A.E.: "Fission Surface Power Primary Test Circuit (FSP-PTC): Initial Testing and EM Pump Performance," NASA Marshall Space Flight Center Internal Document, ER24-07-WBS1.2-001, 2007.
3. Garber, A.E.; Polzin, K.A.; Reid, R.S.; and Pearson, J.B.: "Results from ALIP Tests in the Fission Surface Power Primary Test Circuit (FSP-PTC)," NASA Marshall Space Flight Center Internal Document, ER24-08-WBS1.2-002, 2008.
4. Sakai, T.; Gunji, M.; Matsumoto, S.; and Ishii, Y.: "Determination of Oxygen Solubility in NaK-78 by Vacuum Distillation Method," *Journal of Nuclear Science and Technology*, Vol. 20, No. 12, pp. 1032–1038, December 1983.
5. Mausteller, J.W.; Tepper, F.; and Rodgers, S.J.: *Alkali Metal Handling and Systems Operating Techniques*, Gordon and Breach, Science Publishers, Inc., 1967.
6. Zimmerman, C.A.: "Corrosion of the 316 Stainless Steel in NaK Service – A Literature Survey," AEC Research and Development Report, TID-4500, 37th ed., IDO-14651, February 1965.
7. Foust, O.J.: *Sodium-NaK Engineering Handbook, Volume V*, Gordon and Breach, Science Publishers, Inc., 1979.
8. Pohl, L.E.: "Cold Trap," U.S. Patent No. 3,618,770, 1971.
9. Cygan, R.: "HNPF Cold Trap Evaluation," AEC Report NAA-SR-4382, December 1959.
10. Lyon, R.N.: *Liquid-Metals Handbook*, Atomic Energy Commission, Oak Ridge, 1952.
11. Cassidy, F.H.: "Oxides in NaK," *NASA-CR-72963*, AGC-TM-4923:70-614, February 1970.
12. Mills, A.F.: *Basic Heat and Mass Transfer*, 2nd ed., Prentice Hall, Inc., 1999.
13. Pearson, J.B.; Godfroy, T.J.; Reid, R.S.; and Polzin, K.A.: "NaK Plugging Meter Design for the Feasibility Test Loops," *Proceedings of ICAPP '08*, Paper No. 8288, Anaheim, CA, June, 8–12, 2008.

REPORT DOCUMENTATION PAGE			Form Approved OMB No. 0704-0188		
<p>The public reporting burden for this collection of information is estimated to average 1 hour per response, including the time for reviewing instructions, searching existing data sources, gathering and maintaining the data needed, and completing and reviewing the collection of information. Send comments regarding this burden estimate or any other aspect of this collection of information, including suggestions for reducing this burden, to Department of Defense, Washington Headquarters Services, Directorate for Information Operation and Reports (0704-0188), 1215 Jefferson Davis Highway, Suite 1204, Arlington, VA 22202-4302. Respondents should be aware that notwithstanding any other provision of law, no person shall be subject to any penalty for failing to comply with a collection of information if it does not display a currently valid OMB control number.</p> <p><b>PLEASE DO NOT RETURN YOUR FORM TO THE ABOVE ADDRESS.</b></p>					
1. REPORT DATE (DD-MM-YYYY) 01-01-2012		2. REPORT TYPE Technical Publication		3. DATES COVERED (From - To)	
4. TITLE AND SUBTITLE  Development and Analysis of Cold Trap for Use in Fission Surface Power-Primary Test Circuit			5a. CONTRACT NUMBER		
			5b. GRANT NUMBER		
			5c. PROGRAM ELEMENT NUMBER		
6. AUTHOR(S)  T.M. Wolfe,* C.A. Dervan,** J.B. Pearson, and T.J. Godfroy			5d. PROJECT NUMBER		
			5e. TASK NUMBER		
			5f. WORK UNIT NUMBER		
7. PERFORMING ORGANIZATION NAME(S) AND ADDRESS(ES) George C. Marshall Space Flight Center Huntsville, AL 35812			8. PERFORMING ORGANIZATION REPORT NUMBER  M-1329		
9. SPONSORING/MONITORING AGENCY NAME(S) AND ADDRESS(ES) National Aeronautics and Space Administration Washington, DC 20546-0001			10. SPONSORING/MONITOR'S ACRONYM(S) NASA		
			11. SPONSORING/MONITORING REPORT NUMBER NASA/TP-2012-217453		
12. DISTRIBUTION/AVAILABILITY STATEMENT Unclassified-Unlimited Subject Category 20 Availability: NASA CASI (443-757-5802)					
13. SUPPLEMENTARY NOTES Prepared by the Propulsion Systems Department, Engineering Directorate *Department of the Navy, Naval Sea Systems Command, Washington, DC **Georgia Institute of Technology, Atlanta, GA					
14. ABSTRACT  The design and analysis of a cold trap proposed for use in the purification of circulated eutectic sodium potassium (NaK-78) loops is presented. The cold trap is designed to be incorporated into the Fission Surface Power-Primary Test Circuit (FSP-PTC), which incorporates a pumped NaK loop to simulate in-space nuclear reactor-based technology using non-nuclear test methodology as developed by the Early Flight Fission-Test Facility. The FSP-PTC provides a test circuit for the development of fission surface power technology. This system operates at temperatures that would be similar to those found in a reactor (500-800 K). By dropping the operating temperature of a specified percentage of NaK flow through a bypass containing a forced circulation cold trap, the NaK purity level can be increased by precipitating oxides from the NaK and capturing them within the cold trap. This would prevent recirculation of these oxides back through the system, which may help prevent corrosion.					
15. SUBJECT TERMS NaK, purification, alkali metal, nuclear reactor, fission					
16. SECURITY CLASSIFICATION OF:			17. LIMITATION OF ABSTRACT	18. NUMBER OF PAGES	19a. NAME OF RESPONSIBLE PERSON
a. REPORT	b. ABSTRACT	c. THIS PAGE			STI Help Desk at email: help@sti.nasa.gov
U	U	U	UU	36	19b. TELEPHONE NUMBER (Include area code) STI Help Desk at: 443-757-5802



National Aeronautics and  
Space Administration  
IS20  
**George C. Marshall Space Flight Center**  
Huntsville, Alabama 35812

---