



US008124927B2

(12) **United States Patent**
Savchenkov et al.

(10) **Patent No.:** US 8,124,927 B2
(45) **Date of Patent:** Feb. 28, 2012

(54) **DETECTING LIGHT IN WHISPERING-GALLERY-MODE RESONATORS**

(75) Inventors: **Anatoliy Savchenkov**, La Crescenta, CA (US); **Lutfollah Maleki**, Pasadena, CA (US); **Makan Mohageg**, Valley Village, CA (US); **Thanh M. Le**, Duarte, CA (US)

(73) Assignee: **California Institute of Technology**, Pasadena, CA (US)

(*) Notice: Subject to any disclaimer, the term of this patent is extended or adjusted under 35 U.S.C. 154(b) by 1186 days.

5,929,430	A	7/1999	Yao et al.
5,985,166	A	11/1999	Unger et al.
6,080,586	A	6/2000	Baldeschwieler et al.
6,178,036	B1	1/2001	Yao
6,203,660	B1	3/2001	Unger et al.
6,389,197	B1	5/2002	Iltchenko et al.
6,417,957	B1	7/2002	Yao
6,473,218	B1 *	10/2002	Maleki et al. 359/245
6,476,959	B2	11/2002	Yao
6,487,233	B2	11/2002	Maleki et al.
6,488,861	B2	12/2002	Iltchenko et al.
6,490,039	B2 *	12/2002	Maleki et al. 356/436
6,535,328	B2	3/2003	Yao
6,567,436	B1	5/2003	Yao et al.
6,580,532	B1	6/2003	Yao et al.
6,594,061	B2	7/2003	Huang et al.
6,633,696	B1 *	10/2003	Vahala et al. 385/27
6,762,869	B2	7/2004	Maleki et al.

(Continued)

(21) Appl. No.: **11/754,959**

(22) Filed: **May 29, 2007**

(65) **Prior Publication Data**

US 2010/0264300 A1 Oct. 21, 2010

(51) **Int. Cl.**
G02B 6/26 (2006.01)
G02B 6/42 (2006.01)
G02F 1/035 (2006.01)

(52) **U.S. Cl.** **250/227.24**; 385/30

(58) **Field of Classification Search** 250/227.24;
372/26, 27; 385/31, 32, 36, 39, 30
See application file for complete search history.

(56) **References Cited**

U.S. PATENT DOCUMENTS

5,204,640	A	4/1993	Logan, Jr.
5,220,292	A	6/1993	Bianchini et al.
5,723,856	A	3/1998	Yao et al.
5,751,747	A	5/1998	Lutes et al.
5,777,778	A	7/1998	Yao
5,917,179	A	6/1999	Yao

FOREIGN PATENT DOCUMENTS

WO 01/96936 12/2001

(Continued)

OTHER PUBLICATIONS

International Preliminary Report on Patentability dated Dec. 10, 2009 for International Application No. PCT/US2007/069905, filed May 29, 2007 (7 pages).

(Continued)

Primary Examiner — John Lee

(74) *Attorney, Agent, or Firm* — Perkins Coie LLP

(57) **ABSTRACT**

An optical device including a whispering gallery mode (WGM) optical resonator configured to support one or more whispering gallery modes; and a photodetector optically coupled to an exterior surface of the optical resonator to receive evanescent light from the optical resonator to detect light inside the optical resonator.

20 Claims, 6 Drawing Sheets

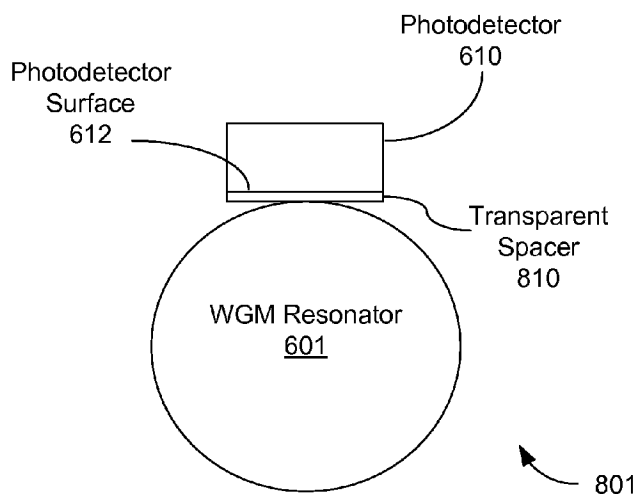

U.S. PATENT DOCUMENTS

6,781,696	B1 *	8/2004	Rosenberger et al.	356/437
6,795,481	B2	9/2004	Maleki et al.	
6,798,947	B2	9/2004	Ilchenko	
6,853,479	B1	2/2005	Ilchenko et al.	
6,871,025	B2	3/2005	Maleki et al.	
6,873,631	B2	3/2005	Yao et al.	
6,879,752	B1	4/2005	Ilchenko et al.	
6,901,189	B1	5/2005	Savchenkov et al.	
6,906,309	B2	6/2005	Sayyah et al.	
6,922,497	B1	7/2005	Savchenkov et al.	
6,928,091	B1	8/2005	Maleki et al.	
6,943,934	B1	9/2005	Ilchenko et al.	
6,987,914	B2	1/2006	Savchenkov et al.	
7,024,069	B2	4/2006	Savchenkov et al.	
7,043,117	B2	5/2006	Matsko et al.	
7,050,212	B2	5/2006	Matsko et al.	
7,061,335	B2	6/2006	Maleki et al.	
7,062,131	B2	6/2006	Ilchenko	
7,085,452	B1	8/2006	Lin et al.	
7,092,591	B2	8/2006	Savchenkov et al.	
7,133,180	B2	11/2006	Ilchenko et al.	
7,173,749	B2	2/2007	Maleki et al.	
7,184,451	B2	2/2007	Ilchenko et al.	
7,187,870	B2	3/2007	Ilchenko et al.	
7,218,662	B1	5/2007	Ilchenko et al.	
7,242,705	B2 *	7/2007	Kneissl et al.	372/67
7,248,763	B1	7/2007	Kossakovski et al.	
7,260,279	B2	8/2007	Gunn et al.	
7,283,707	B1	10/2007	Maleki et al.	
7,369,722	B2	5/2008	Yilmaz et al.	
7,389,053	B1	6/2008	Ilchenko et al.	
7,400,796	B1	7/2008	Kossakovski et al.	
7,440,651	B1	10/2008	Savchenkov et al.	
7,460,746	B2	12/2008	Maleki et al.	
7,595,890	B2 *	9/2009	Fan et al.	356/480
7,630,417	B1 *	12/2009	Maleki et al.	372/20
7,729,047	B1 *	6/2010	Savchenkov et al.	359/346
7,777,583	B2 *	8/2010	Taber et al.	331/96
7,801,189	B2 *	9/2010	Maleki et al.	372/26
2001/0038651	A1	11/2001	Maleki et al.	
2002/0018611	A1	2/2002	Maleki et al.	
2002/0018617	A1	2/2002	Ilchenko et al.	
2002/0021765	A1	2/2002	Maleki et al.	
2002/0081055	A1	6/2002	Painter et al.	
2002/0085266	A1	7/2002	Yao	
2002/0097401	A1	7/2002	Maleki et al.	
2003/0160148	A1	8/2003	Yao et al.	
2004/0100675	A1	5/2004	Matsko et al.	
2004/0109217	A1	6/2004	Maleki et al.	
2004/0202422	A1	10/2004	Gunn, III	
2004/0218880	A1	11/2004	Matsko et al.	
2004/0240781	A1	12/2004	Savchenkov et al.	
2005/0017816	A1	1/2005	Ilchenko et al.	
2005/0063034	A1	3/2005	Maleki et al.	
2005/0074200	A1	4/2005	Savchenkov et al.	
2005/0088657	A1	4/2005	Sugawara et al.	
2005/0123306	A1	6/2005	Ilchenko et al.	
2005/0128566	A1	6/2005	Savchenkov et al.	
2005/0135453	A1 *	6/2005	Kneissl et al.	372/94
2005/0175358	A1	8/2005	Ilchenko et al.	
2005/0210989	A1	9/2005	Ja et al.	
2005/0248823	A1	11/2005	Maleki et al.	
2007/0009205	A1	1/2007	Maleki et al.	
2007/0153289	A1	7/2007	Yilmaz et al.	
2007/0230870	A1 *	10/2007	Smith et al.	385/32
2007/0274621	A1 *	11/2007	Clapp	385/3
2008/0001062	A1	1/2008	Gunn et al.	
2008/0008418	A1 *	1/2008	Smith et al.	385/32
2008/0075464	A1	3/2008	Maleki et al.	
2008/0265147	A1 *	10/2008	Fan et al.	250/227.24
2008/0310463	A1	12/2008	Maleki et al.	
2009/0097516	A1 *	4/2009	Maleki et al.	372/26

FOREIGN PATENT DOCUMENTS

WO	2005/038513	4/2005
WO	2005/055412	6/2005
WO	2005/067690	7/2005

WO	2005/122346	12/2005
WO	2006/076585	7/2006
WO	2007/143627	12/2007

OTHER PUBLICATIONS

Braginsky, V.B., et al., "Quality-Factor and Nonlinear Properties of Optical Whispering-Gallery Modes," *Physics Letters A*, 137(7, 8):393-397, May 1989.

Eliyahu, D., et al., "Low Phase Noise and Spurious Levels in Multi-Loop Opto-Electronic Oscillators," *Proceedings of the 2003 IEEE International Frequency Control Symposium and PDA Exhibition*, pp. 405-410, May 2003.

Eliyahu, D., et al., "Modulation Response (S_{21}) of the Coupled Opto-Electronic Oscillator," *Proceedings of the 2005 IEEE International Frequency Control Symposium and Exposition*, pp. 850-856, Aug. 2005.

Eliyahu, D., et al., "Tunable, Ultra-Low Phase Noise YIG Based Opto-Electronic Oscillator," *IEEE MTT-S International Microwave Symposium Digest*, 3:2185-2187, Jun. 2003.

Gorodetsky, M.L., et al., "Optical Microsphere Resonators: Optimal Coupling to High-Q Whispering-Gallery Modes," *J. Opt. Soc. Am. B*, 16(1):147-154, Jan. 1999.

Gorodetsky, M.L., et al., "Rayleigh Scattering in High-Q Microspheres," *J. Opt. Soc. Am. B*, 17(6):1051-1057, Jun. 2000.

Gorodetsky, M.L., et al., "Ultimate Q of Optical Microsphere Resonators," *Optics Letters*, 21(7):453-455, Apr. 1996.

Hryniewicz, J.V., et al., "Higher Order Filter Response in Coupled Microring Resonators," *IEEE Photonics Technology Letters*, 12(3):320-322, Mar. 2000.

Huang, S., et al., "A 'Turnkey' Optoelectronic Oscillator with Low Acceleration Sensitivity," *2000 IEEE/EIA International Frequency Control Symposium and Exhibition*, pp. 269-279, Jun. 2000.

Ilchenko, V., et al., "Electrooptically Tunable Photonic Microresonators and Photonic Bandgap Waveguide Coupling for Micro-Optoelectronic Oscillators," *GOMACTech 2003*, Tampa, Florida, pp. 1-4.

Ilchenko, V., et al., "High-Q Microsphere Cavity for Laser Stabilization and Optoelectronic Microwave Oscillator," *Proceedings SPIE Microresonators and Whispering-Gallery Modes*, vol. 3611, pp. 190-198, Jan. 1999.

Ilchenko, V., et al., "Microsphere Integration in Active and Passive Photonics Devices," *Proc. of SPIE Laser Resonators III*, vol. 3930, pp. 154-162, Jan. 2000.

Ilchenko, V., et al., "Microtorus: A High-Finesse Microcavity with Whispering-Gallery Modes," *Optics Letters*, 26(5):256-258, Mar. 2001.

Ilchenko, V., et al., "Pigtailing the High-Q Microsphere Cavity: A Simple Fiber Coupler for Optical Whispering-Gallery Modes," *Optics Letters*, 24(11):723-725, Jun. 1999.

Ilchenko, V., et al., "Tunability and Synthetic Lineshapes in High-Q Optical Whispering Gallery Modes," *Proc. of SPIE Laser Resonators and Beam Control VI*, vol. 4969, pp. 195-206, Jan. 2003.

Ilchenko, V., et al., "Whispering-Gallery-Mode Electro-Optic Modulator and Photonic Microwave Receiver," *J. Opt. Soc. Am. B*, 20(2):333-342, Feb. 2003.

Ilchenko, V., et al., "Sub-Micro Watt Photonic Microwave Receiver," *IEEE Photonics Technology Letters*, 14(11):1602-1604, Nov. 2002.

Ito, H., et al., "InP/InGaAs Uni-Travelling-Carrier Photodiode with 310 GHz Bandwidth," *Electronics Letters*, 36(21):1809-1810, Oct. 2000.

Logan, R., et al., "Stabilization of Oscillator Phase Using a Fiber-Optic Delay-Line," *IEEE 45th Annual Symposium on Frequency Control*, pp. 508-512, May 1991.

Maleki, L., "The Opto-Electronic Oscillator: Prospects for Extending the State of the Art in Reference Frequency Generation," *International Topical Meeting on Microwave Photonics*, pp. 195-198, Oct. 1998.

Matsko, A., et al., "Active Mode Locking with Whispering-Gallery Modes," *J. Opt. Soc. Am. B*, 20(11):2292-2296, Nov. 2003.

Matsko, A., et al., "Whispering-Gallery-Mode based Optoelectronic Microwave Oscillator," *Journal of Modern Optics*, 50(15-17):2523-2542, Feb. 2004.

- Matsko, A., et al., "Whispering-Gallery-Mode Resonators as Frequency References. I. Fundamental Limitations," *J. Opt. Soc. Am. B*, 24(6):1324-1335, Jun. 2007.
- Myers, L.E., et al., "Quasi-Phase-Matched Optical Parametric Oscillators in Bulk Periodically Poled LiNbO₃," *J. Opt. Soc. Am. B*, 12(11):2102-2116, Nov. 1995.
- Savchenkov, A., et al., "Whispering-Gallery-Mode Resonators as Frequency References. II. Stabilization," *J. Opt. Soc. Am. B*, 24(12):2988-2997, Dec. 2007.
- Vassiliev, V.V., et al., "Narrow-Line-Width Diode Laser with a High-*Q* Microsphere Resonator," *Optics Communications*, 158(1-6):305-312, Dec. 1998.
- Yao, X.S., et al., "A Novel Photonic Oscillator," *Digest of the LEOS Summer Topical Meetings*, pp. 17-18, Aug. 1995.
- Yao, X.S., et al., "A Novel Photonic Oscillator," *TDA Progress Report 42-122*, pp. 32-43, Aug. 1995.
- Yao, X.S., et al., "Converting Light into Spectrally Pure Microwave Oscillation," *Optics Letters*, 21(7):483-485, Apr. 1996.
- Yao, X.S., et al., "Coupled Optoelectronic Oscillators for Generating Both RF Signal and Optical Pulses," *Journal of Lightwave Technology*, 18(1):73-78, Jan. 2000.
- Yao, X.S., et al., "Dual Microwave and Optical Oscillator," *Optics Letters*, 22(24):1867-1869, Dec. 1997.
- Yao, X.S., et al., "Multiloop Optoelectronic Oscillator," *IEEE Journal of Quantum Electronics*, 36(1):79-84, Jan. 2000.
- Yao, X.S., et al., "Optoelectronic Microwave Oscillator," *J. Opt. Soc. Am. B*, 13(8):1725-1735, Aug. 1996.
- Yao, X.S., et al., "Optoelectronic Oscillator for Photonic Systems," *IEEE Journal of Quantum Electronics*, 32(7):1141-1149, Jul. 1996.
- Yu, J., et al., "Compact Optoelectronic Oscillator with Ultra-Low Phase Noise Performance," *Electronics Letters*, 35(18):1554-1555, Sep. 1999.

* cited by examiner

FIG. 1

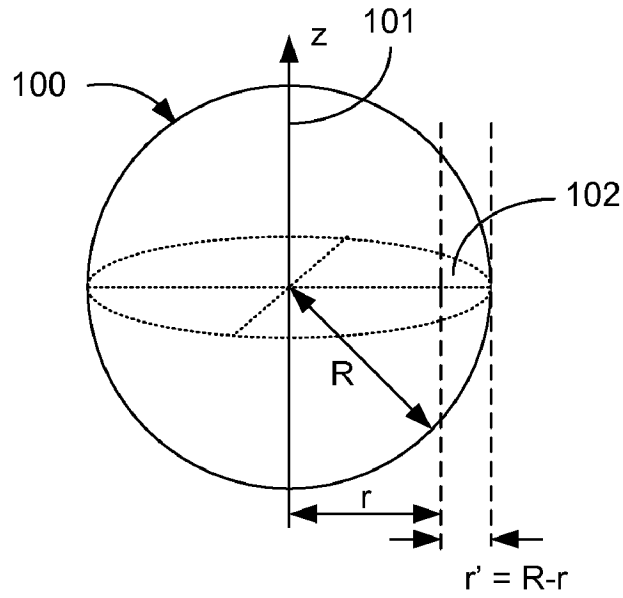

FIG. 2

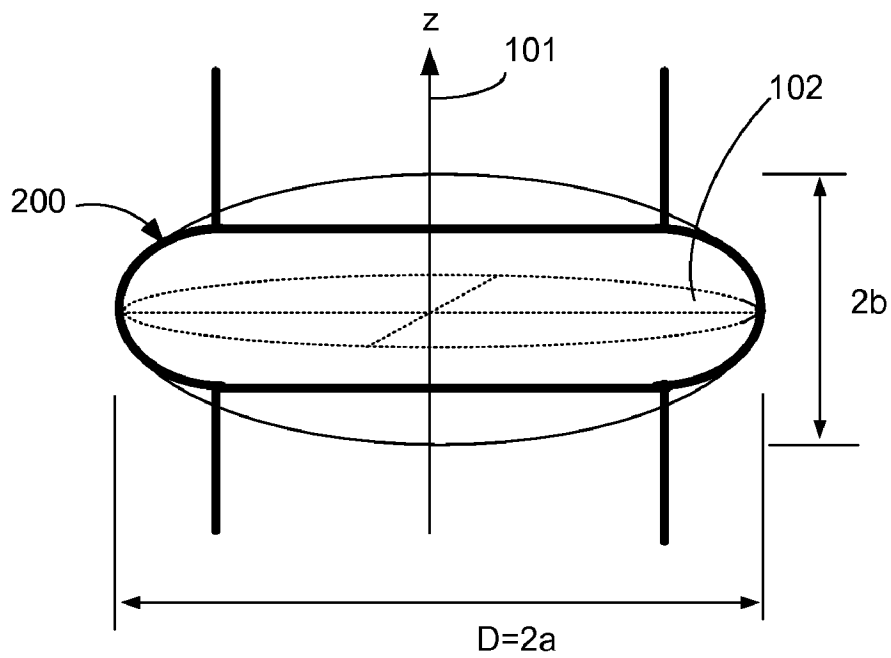

FIG. 3

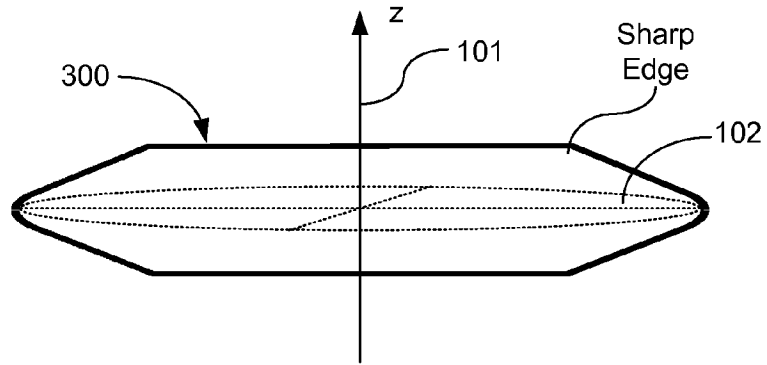

FIG. 4A

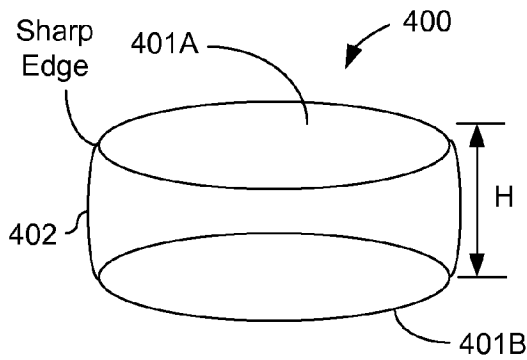

FIG. 4B

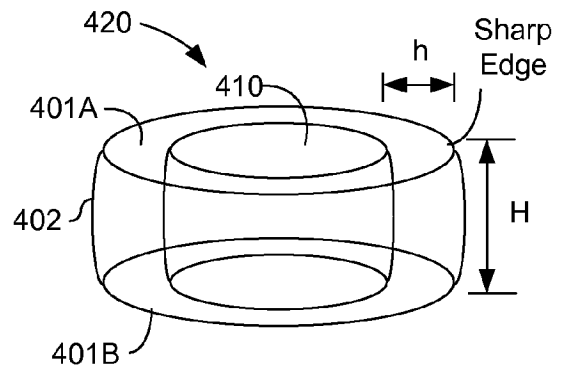

FIG. 5A

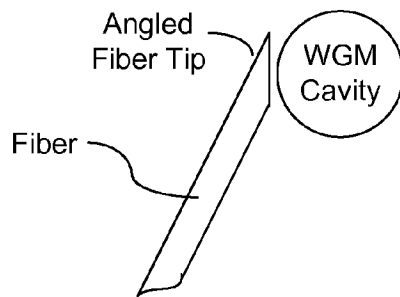

FIG. 5B

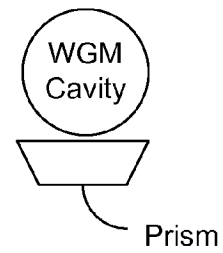

FIG. 6

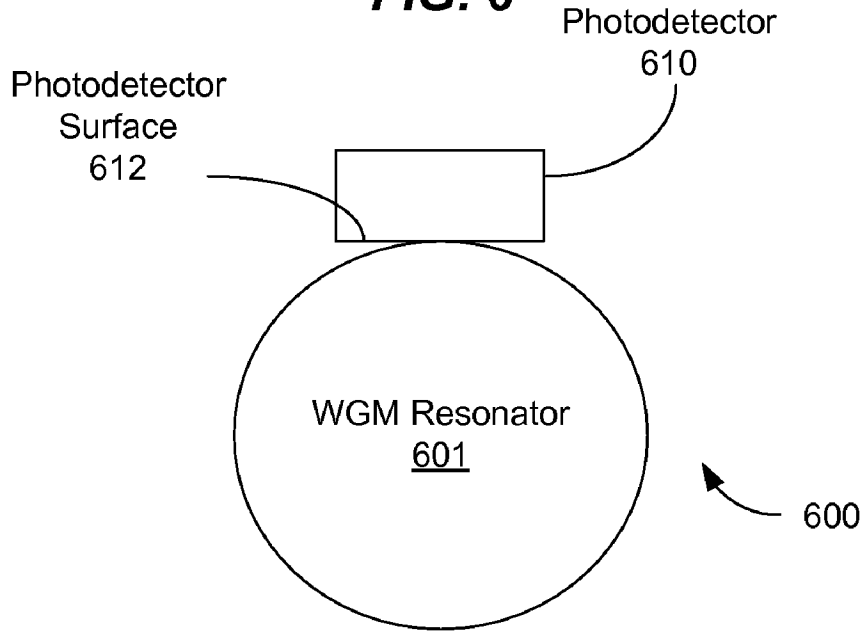

FIG. 7

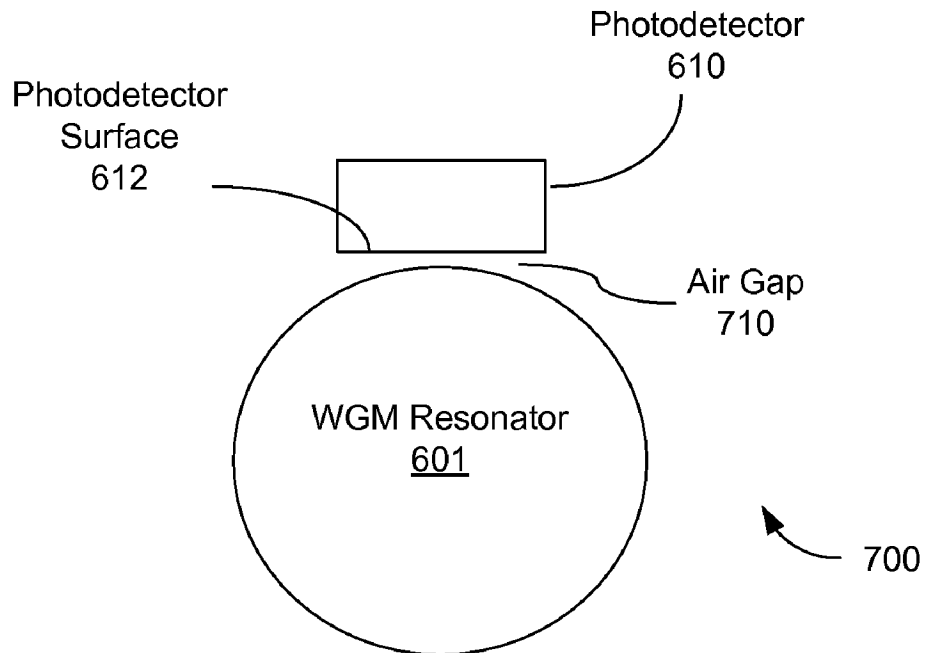

FIG. 8A

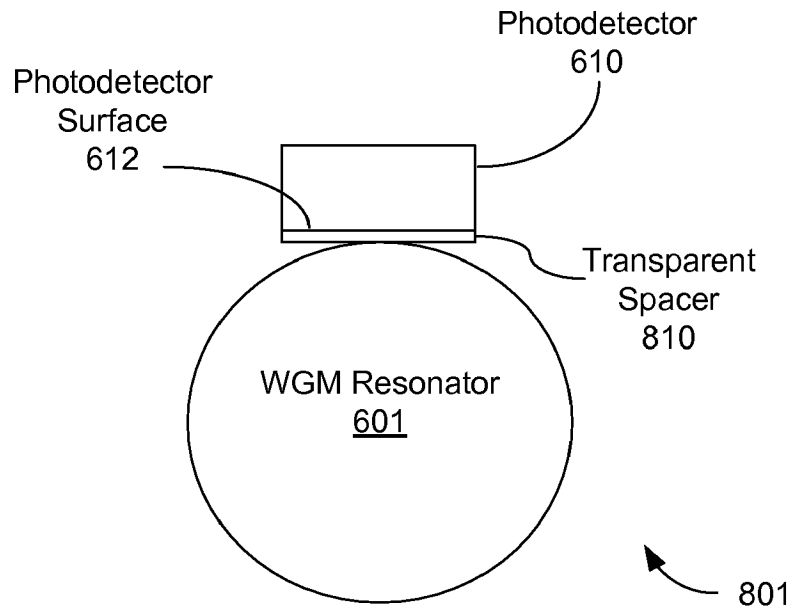

FIG. 8B

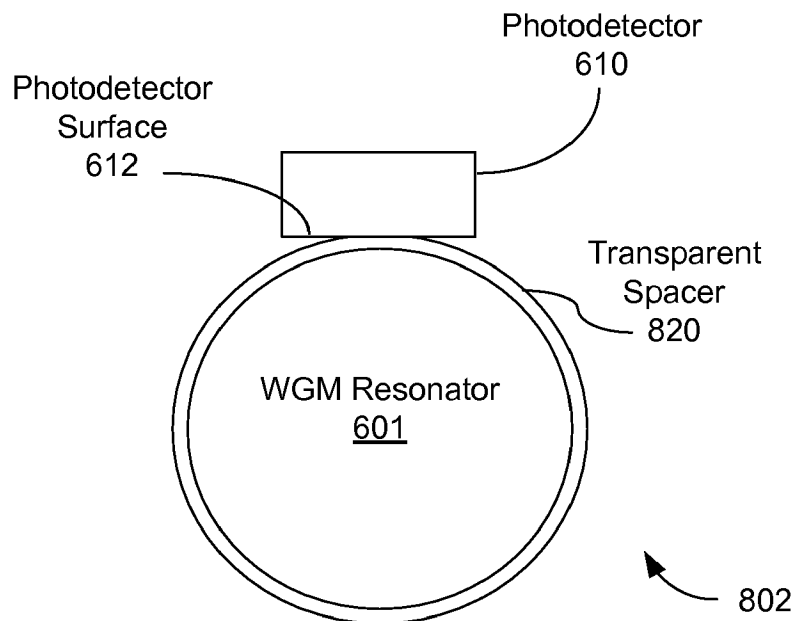

FIG. 9

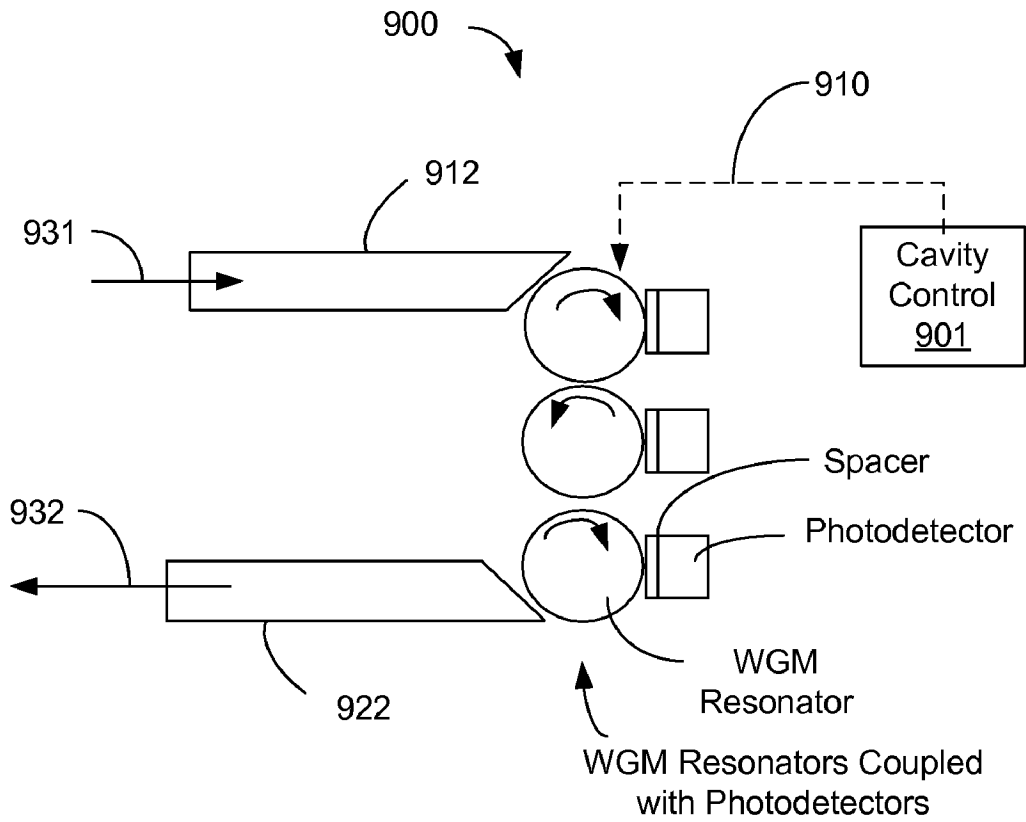

FIG. 10A

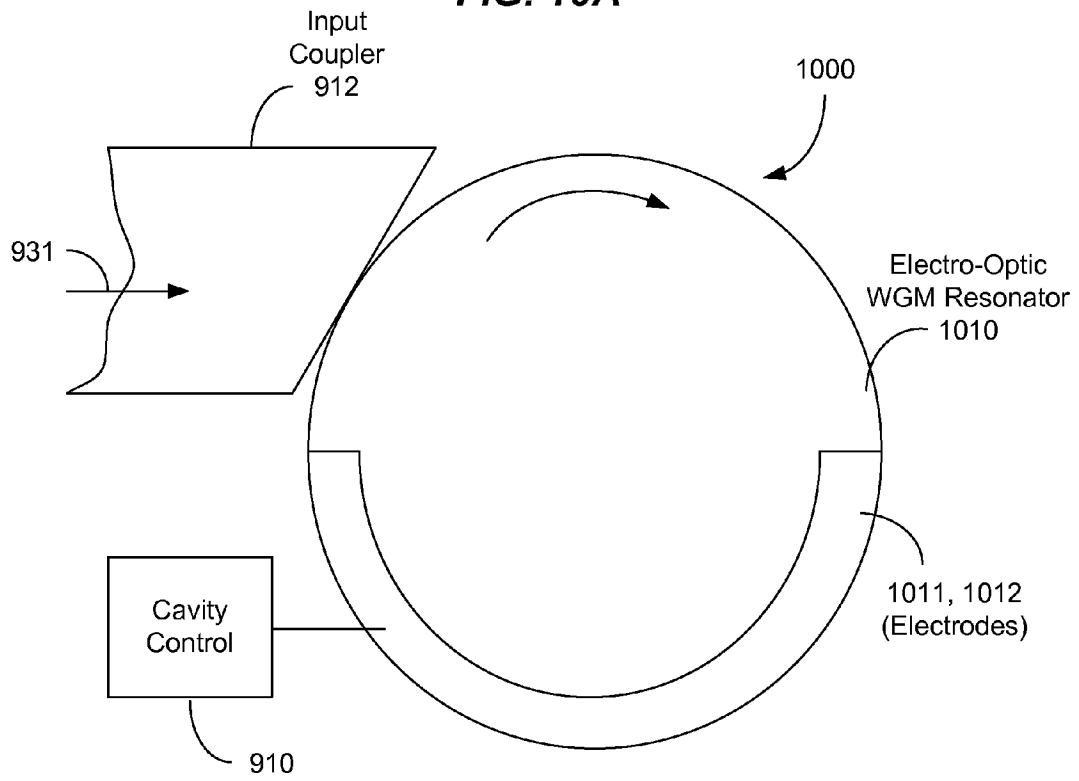
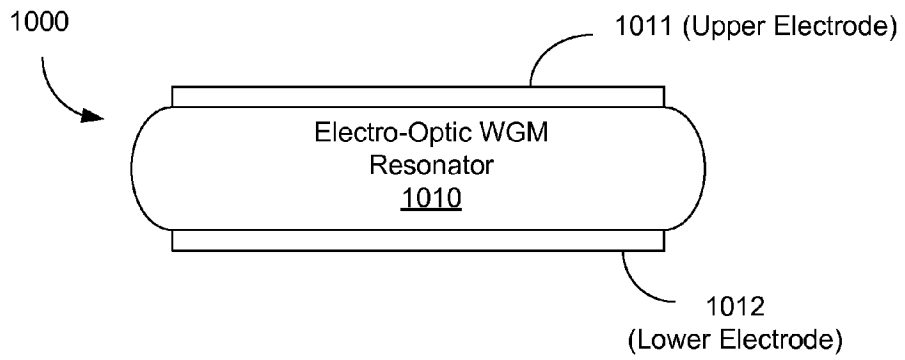

FIG. 10B



1

DETECTING LIGHT IN WHISPERING-GALLERY-MODE RESONATORS

STATEMENT REGARDING FEDERALLY
SPONSORED RESEARCH

The systems and techniques described herein were made in the performance of work under a NASA contract, and are subject to the provisions of Public Law 96-517 (35 USC 202) in which the Contractor has elected to retain title.

BACKGROUND

This application relates to optical resonators and cavities. A dielectric material may be shaped to construct an optical whispering-gallery-mode (“WGM”) resonator which supports one or more whispering gallery (“WG”) modes. These WG modes represent optical fields confined in an interior region close to the surface of the resonator due to the total internal reflection at the boundary. For example, microspheres with diameters from few tens of microns to several hundreds of microns have been used to form compact optical WGM resonators. Such a spherical resonator can include at least a portion of the sphere that comprises the sphere’s equator. The resonator dimension is generally much larger than the wavelength of light so that the optical loss due to the finite curvature of the resonators is small. As a result, a high quality factor, Q , may be achieved in such resonators. Some microspheres with sub-millimeter dimensions have been demonstrated to exhibit very high quality factors for light waves, ranging from 10^3 to 10^9 for quartz microspheres. Hence, optical energy, once coupled into a whispering gallery mode, can circulate within the WGM resonator with a long photon life time. Such hi- Q WGM resonators may be used in many optical applications, including optical filtering, optical delay, optical sensing, lasers, and opto-electronic oscillators.

SUMMARY

In one implementation, an optical device can include a whispering gallery mode (WGM) optical resonator configured to support one or more whispering gallery modes; and a photodetector optically coupled to an exterior surface of the optical resonator to receive evanescent light from the optical resonator to detect light inside the optical resonator. The photodetector may be in direct contact with the exterior surface of the optical resonator. The photodetector may also be separated from the exterior surface of the optical resonator by a gap. In addition, a transparent material may be placed between the photodetector and the exterior surface of the optical resonator.

In another implementation, an optical device can include first and second optical resonators each configured to support whispering gallery modes. The first and said second optical resonators are optically coupled to each other to allow for light coupling from a first whispering gallery mode in the first optical resonator to a second whispering gallery mode in the second optical resonator. This device can also include a first photodetector optically coupled to the first optical resonator to detect light in the first optical resonator; and a second photodetector optically coupled to the second optical resonator to detect light in the second optical resonator.

A method is also provided in this application where a photodetector is placed near or in contact with an exterior surface of a whispering gallery mode (WGM) optical resonator to optically couple the photodetector to an evanescent

2

field of light in the optical resonator. The photodetector is used to receive evanescent light from the optical resonator to detect light inside the optical resonator.

These and other implementations are now described in greater detail in the following drawings, the detailed description, and the claims.

BRIEF DESCRIPTION OF THE DRAWINGS

FIGS. 1, 2, 3, 4A, and 4B illustrate various exemplary resonator configurations that support whispering gallery modes.

FIGS. 5A and 5B illustrate two evanescent coupling examples.

FIGS. 6, 7, 8A and 8B show three examples of WGM resonators that are directly coupled to a photodetector.

FIG. 9 shows an optical filter with two or more WGM resonators cascaded to form an optical filter where each WGM resonator is directly coupled to a photodetector.

FIGS. 10A and 10B show one implementation of a tunable WGM resonator based on an electro-optic effect.

DETAILED DESCRIPTION

Examples and implementations of optical devices in this application include a whispering gallery mode (WGM) optical resonator configured to support one or more whispering gallery modes, and a photodetector optically coupled to an exterior surface of the optical resonator to receive evanescent light from the optical resonator to detect light inside the optical resonator. The photodetector can be a semiconductor photodetector (e.g., Si, Ge, InGaAs, etc.) and has a sensing surface that is placed in the evanescent field of light confined in the optical resonator. The photodetector can be in direct contact with or spaced from an exterior surface of the optical resonator to directly and evanescently coupled to the optical resonator.

The geometries of the WGM resonators may be in various configurations. FIGS. 1, 2, and 3 illustrate three exemplary geometries for implementing such WGM resonators.

FIG. 1 shows a spherical WGM resonator **100** which is a solid dielectric sphere. The sphere **100** has an equator in the plane **102** which is symmetric around the z axis **101**. The circumference of the plane **102** is a circle and the plane **102** is a circular cross section. A WGM mode exists around the equator within the spherical exterior surface and circulates within the resonator **100**. The spherical curvature of the exterior surface around the equator plane **102** provides spatial confinement along both the z direction and its perpendicular direction to support the WG modes. The eccentricity of the sphere **100** generally is low.

FIG. 2 shows an exemplary spheroidal microresonator **200**. This resonator **200** may be formed by revolving an ellipse (with axial lengths a and b) around the symmetric axis along the short elliptical axis **101** (z). Therefore, similar to the spherical resonator in FIG. 1, the plane **102** in FIG. 2 also has a circular circumference and is a circular cross section. Different from the design in FIG. 1, the plane **102** in FIG. 2 is a circular cross section of the non-spherical spheroid and around the short ellipsoid axis of the spheroid. The eccentricity of resonator **100** is $(1-b^2/a^2)^{1/2}$ and is generally high, e.g., greater than 10^{-1} . Hence, the exterior surface is the resonator **200** is not part of a sphere and provides more spatial confinement on the modes along the z direction than a spherical exterior. More specifically, the geometry of the cavity in the plane in which Z lies such as the zy or zx plane is elliptical. The equator plane **102** at the center of the resonator **200** is

3

perpendicular to the axis **101** (z) and the WG modes circulate near the circumference of the plane **102** within the resonator **200**.

FIG. **3** shows another exemplary WGM resonator **300** which has a non-spherical exterior where the exterior profile is a general conic shape which can be mathematically represented by a quadratic equation of the Cartesian coordinates. Similar to the geometries in FIGS. **1** and **2**, the exterior surface provides curvatures in both the direction in the plane **102** and the direction of z perpendicular to the plane **102** to confine and support the WG modes. Such a non-spherical, non-elliptical surface may be, among others, a parabola or hyperbola. The plane **102** in FIG. **3** is a circular cross section and a WG mode circulates around the circle in the equator.

The above three exemplary geometries in FIGS. **1**, **2**, and **3** share a common geometrical feature that they are all axially or cylindrically symmetric around the axis **101** (z) around which the WG modes circulate in the plane **102**. The curved exterior surface is smooth around the plane **102** and provides two-dimensional confinement around the plane **102** to support the WG modes.

Notably, the spatial extent of the WG modes in each resonator along the z direction **101** is limited above and below the plane **102** and hence it may not be necessary to have the entirety of the sphere **100**, the spheroid **200**, or the conical shape **300**. Instead, only a portion of the entire shape around the plane **102** that is sufficiently large to support the whispering gallery modes may be used for the WGM resonator. For example, rings, disks and other geometries formed from a proper section of a sphere may be used as a spherical WGM resonator.

FIGS. **4A** and **4B** show a disk-shaped WGM resonator **400** and a ring-shaped WGM resonator **420**, respectively. In FIG. **4A**, the solid disk **400** has a top surface **401A** above the center plane **102** and a bottom surface **401B** below the plane **102** with a distance H . The value of the distance H is sufficiently large to support the WG modes. Beyond this sufficient distance above the center plane **102**, the resonator may have sharp edges as illustrated in FIGS. **3**, **4A**, and **4B**. The exterior curved surface **402** can be selected from any of the shapes shown in FIGS. **1**, **2**, and **3** to achieve desired WG modes and spectral properties. The ring resonator **420** in FIG. **4B** may be formed by removing a center portion **410** from the solid disk **400** in FIG. **4A**. Since the WG modes are present near the exterior part of the ring **420** near the exterior surface **402**, the thickness h of the ring may be set to be sufficiently large to support the WG modes.

An optical coupler is generally used to couple optical energy into or out of the WGM resonator by evanescent coupling. FIGS. **5A** and **5B** show two exemplary optical couplers engaged to a WGM resonator. The optical coupler may be in direct contact with or separated by a gap from the exterior surface of the resonator to effectuate the desired critical coupling. FIG. **5A** shows an angle-polished fiber tip as a coupler for the WGM resonator. A waveguide with an angled end facet, such as a planar waveguide or other waveguide, may also be used as the coupler. FIG. **5B** shows a micro prism as a coupler for the WGM resonator. Other evanescent couplers may also be used, such as a coupler formed from a photonic bandgap material.

In WGM resonators with uniform indices, a part of the electromagnetic field of the WG modes is located at the exterior surface of the resonators. A gap between the optical coupler and the WGM resonator with a uniform index is generally needed to achieve a proper optical coupling. This gap is used to properly "unload" the WG mode. The Q-factor of a WG mode is determined by properties of the dielectric

4

material of the WGM resonator, the shape of the resonator, the external conditions, and strength of the coupling through the coupler (e.g. prism). The highest Q-factor may be achieved when all the parameters are properly balanced to achieve a critical coupling condition. In WGM resonators with uniform indices, if the coupler such as a prism touches the exterior surface of the resonator, the coupling is strong and this loading can render the Q factor to be small. Hence, the gap between the surface and the coupler is used to reduce the coupling and to increase the Q factor. In general, this gap is very small, e.g., less than one wavelength of the light to be coupled into a WG mode. Precise positioning devices such as piezo elements may be used to control and maintain this gap at a proper value.

A photodetector can be in direct contact with or spaced from an exterior surface of the optical resonator to directly and evanescently couple to the optical resonator to receive light from the optical resonator. FIGS. **6**, **7** and **8A** and **8B** show example configurations for coupling such a photodetector to a WGM resonator.

FIG. **6** shows a WGM resonator **601** in direct contact with a photodetector **610**. The photodetector **610** includes a photodetector surface **612** to receive light for detection. This surface **612** is placed in contact with the exterior surface of the WGM resonator **601** so that the light in the evanescent field of a WG mode in the optical resonator **601** is received by the surface **612** and the received light is converted into a detector signal.

FIG. **7** shows another coupling design where a WGM resonator **601** and a photodetector **610** are spaced from each other by an air gap **710**. The gap **710** is sufficiently small so that the photodetector surface **612** is within the reach of the evanescent field of a WG mode in the optical resonator **601** and the received light is converted into a detector signal.

The optical coupling between the photodetector **610** and the WGM resonator **601** is stronger in the configuration in FIG. **6** than that in FIG. **7**. Such coupling can affect the quality factor Q of the WGM resonator **601**. The gap **710** in the configuration in FIG. **7** can be adjusted to adjust the coupling strength to maintain a desired Q for the WGM resonator **601**.

FIGS. **8A** and **8B** show two examples where a transparent spacer or a lightspan spacer is placed between the photodetector **610** and the WGM resonator **601** to allow for direct coupling of light from the resonator **601** into the detector **610**. The thickness of the spacer can be controlled to set the coupling strength between the photodetector **610** and the WGM resonator **601**. To reduce the Q of the resonator **601**, the thickness of the spacer can be reduced. The thickness of the spacer can be increased to decrease the detector-resonator coupling and to increase the Q of the resonator **601**. In one implementation, the refractive index of the spacer is less than the refractive index of the photodetector **610** and the refractive index of the WGM resonator **601**. A polymer material, for example, can be used to implement such a spacer. As a specific example in a CaF₂ WGM resonator, a polymer coating with a refractive index around 1.33 and a thickness of 50 to 150 nm can be placed on a detector surface as the spacer.

In FIG. **8A**, the spacer is a transparent layer **810** coated on the surface **612** of the photodetector **610** and the layer **810** is in contact with the exterior of the WGM resonator **601**. In FIG. **8B**, the spacer is a transparent layer coated on the exterior of the WGM resonator **601** and the surface **612** of the photodetector **610** is placed in direct contact with the layer **820**. The thickness of the spacer can be set during the coating process for a desired coupling strength. The photodetector **610** can be placed on a metal strip line that provides electrical contact for the photodetector **610**.

5

The above direct coupling between the photodetector **610** and the WGM resonator **601** eliminates the need for an optical coupler between the photodetector **610** and the WGM resonator **601** and associated alignment operations for aligning the optical coupler to the WGM resonator **601**. Hence, the photodetector **610** and the WGM resonator **601** are integrated to each other with direct optical coupling. This integrated assembly of the photodetector **610** and the WGM resonator **601** can be used in various applications.

For example, such an integrated assembly of the photodetector **610** and the WGM resonator **601** can be used as an optical filter. A single WGM resonator as an optical filter generally produces a Lorentzian-shaped filter function. Non-Lorentzian filter functions may be desirable in certain applications. For example, a sharper spectral roll-off than the typical Lorentzian filter function may be desired filtering certain optical signals. As another example, it may be desirable to have a relatively flatter spectral passband than a Lorentzian filter function. A composite filter may thus be constructed to produce such and other non-Lorentzian filter functions by optically cascading and coupling two or more WGM resonators. In this composite filter, an input optical signal passes through the WGM resonators and is filtered more than once to produce the desired output spectral profile in the optical transmission of the filter.

In designing such a composite filter, the resonator frequencies of the cascaded WGM resonators are set to be close to one another to overlap their respective filter functions. It is desirable that the relative positions of the resonator frequencies are properly selected in order to achieve the desired filter function for the composite filter. Certainly, the relative positions of the resonator frequencies may be permanently fixed during fabrication of the WGM resonators and assembly of the composite filter. However, it may be preferable that such a composite filter be tunable so that a specific composite filter function may be generated and changed at a user's choice. The tuning is temporary in the sense that the composite filter function is constant when the corresponding control signal is set a particular state or value. As the control signal is adjusted, the composite filter function is also changed accordingly. Therefore, the composite filter may be dynamically adjusted during operation of the filter or set to produce different filter functions for different operating conditions or in different applications. This tunability in the non-Lorentzian filter function can provide the user with the flexibility in using the same composite filter in different operating conditions and in different applications.

FIG. **9** shows an exemplary composite filter having three cascaded WGM resonators optically cascaded with one another. The resonators may be identical and may be different. In some implementations, the resonators may have approximately the same diameter or dimension to have similar quality factors. In certain other implementations, it may be advantageous to use different resonators with different geometries or physical dimension to use their difference in the spectral profile to produce the desired composite filter function. Two adjacent resonators are placed close to or in contact with each other to allow for direct optical coupling under proper resonance conditions. Alternatively, an optical coupling mechanism may be placed between two adjacent resonators to assist and facilitate the inter-resonator optical coupling. An input optical coupler **912** is placed near or in contact with the first resonator to couple an input optical signal **931** into the first resonator of the filter **900**. An output optical coupler **922** is placed near or in contact with the third resonator to couple optical energy inside the third resonator out to produce an output optical signal **932** as the transmission of the

6

filter **900**. A support base, such as a substrate, may be used to hold and fix the components of the filter **600** in position. Implementation of additional cascaded resonators allows for additional flexibility in designing the final composite filter function and produces higher order filter functions.

In one implementation, at least one resonator in FIG. **9** can be a tunable WGM resonator. A cavity control unit **901** is coupled to control and tune the tunable resonator via a control signal **910**. In general, the tunable resonator may be tuned in any suitable manner by using the control signal **910** to adjust a parameter of the resonator, e.g., a direct change in its refractive index, its temperature, its geometry, etc. Such a change causes the cavity resonance to shift relative to the resonance of another resonator, or other parameter in the output of the tunable resonator (e.g., the linewidth) to change. The corresponding control signal may be adjusted to tune and set the resonator to any point within the operating range if needed.

Various mechanisms may be used to tune a WGM resonator. The dielectric material, the shape and dimension of the resonator, the conditions of the surroundings of the resonator, and the coupling of the optical coupler for the resonator may affect the spectral properties of the resonator. For a given dielectric material under known surrounding conditions, a resonator may be tuned to alter its spectral properties by changing the shape of the resonator through, e.g., stretching or compressing the resonator. In another example, the temperature of the resonator may be controlled to change both of its dimension and its refractive index to change the filter function of the resonator.

In particular, a WGM resonator may be made of a material whose index changes in response to an applied stimulus such as a radiation field or an electric field. Such tuning mechanisms avoid certain complications associated with a change in the shape or dimension of the resonator. For example, an electro-optic material may be used to construct the WGM resonator and an external electric field may be applied to change the refractive index of the resonator in tuning the resonator.

FIGS. **10A** and **10B** shows an example of a tunable electro-optic WGM resonator **1000** used as the first resonator **610** in FIG. **9A**. Such an electro-optic WGM resonator may also be used as the second resonator in FIG. **9A**. The electro-optic material for the resonator **1000** may be any suitable material, including an electro-optic crystal such as Lithium Niobate and semiconductor multiple quantum well structures. One or more electrodes **1011** and **1012** may be formed on the resonator **1000** to apply the control electrical field in the region where the WG modes are present to control the index of the electro-optical material and to change the filter function of the resonator. Assuming the resonator **1000** has disk or ring geometry as in FIG. **4A** or **4B**, the electrode **1011** may be formed on the top of the resonator and the electrode **1012** may be formed on the bottom of the resonator as illustrated in the side view of the device in FIG. **10B**. In one implementation, the electrodes **1011** and **1012** may constitute an RF or microwave resonator to apply the RF or microwave signal to co-propagate along with the desired optical WG mode. The electrodes **1011** and **1012** may be microstrip line electrodes.

In the above optical filters with two or more coupled WGM resonators, at least one of the coupled WGM resonators may be made of a radiation-sensitive material for permanently tuning the spectral properties of the WGM resonator by illumination of the resonator with sensitizing light after it is fabricated and without changing the geometry of the resonator. In one implementation, for example, a dielectric material transparent to radiation of wavelengths in a first radiation spectral range is configured to change a refractive index of the

material when exposed to sensitizing radiation at a sensitizing wavelength in a second radiation spectral range. The first spectral range may be any range in which the resonator is to be operated, such as wavelengths around 1550 nm for optical communications. The second spectral range is different and separate from the first spectral range, such as the UV range or other suitable spectral ranges different from the spectral range of the light in WG modes. A micro resonator is fabricated from the dielectric material to support whispering gallery modes for radiation in the first radiation spectral range. Next, the fabricated resonator is exposed to radiation at the sensitizing wavelength in the second radiation spectral range to modify the refractive index of the resonator until the refractive index is changed to a desired value at which the resonator produces a desired resonator spectrum in the first spectral range.

The above change of the index by exposure to the sensitizing radiation is generally permanent. This may be achieved by doping the dielectric material with radiation-sensitive ions, e.g., a Ge-doped silica that is sensitive to UV sensitizing light. Under this approach, the change in the index of the resonator is controlled by controlling the exposure. A number of advantages can be achieved with this approach. For example, the permanent nature of the change in the index avoids the technical difficulties of maintaining the precise amount of stretching or compression on the resonator in typical mechanical approaches. Different WGM resonators may be tuned with this approach to have one or more common resonator frequencies. A WGM resonator may be so tuned to a desired resonator frequency in a systematic and controllable manner. In addition, different resonant frequencies of such a resonator can be tuned at the same time as a whole so that there is no need for correcting relative shifts of spectral lines. This approach is simple without complex mechanical controls or chemical processing steps. The tuning may be monitored and controlled with desired precision.

One convenient implementation of the radiation-sensitive material for any of above WGM resonator configurations is to use a UV-sensitive material to fabricate the resonator. After the resonator is fabricated, the resonator is exposed to the UV light at the proper wavelength to change the index. Ge-doped silica, for example, has low optical losses at about 1550 nm and a high sensitivity to UV sensitizing light. It is possible to shift the index of such a silica by an amount of about 10^{-2} to 10^{-4} with proper amount of exposure to the UV light at about 351 nm. In the frequency domain, an eigen frequency of 200 THz of a WGM resonator may be shifted from 10 to 1000 GHz. For a microsphere resonator with a diameter of about 1000 microns, This shift is close to the free spectral range of the resonator. Hence, with this large tuning range comparable to the free spectral range, it is possible to design and engineer the eigen frequency of a WGM resonator to be at any desired frequency.

Referring back to the tunable filter shown FIG. 9, at least one of the WGM resonators may be made of a radiation-sensitive material to permanently tune their relative spectral properties by exposure to a proper amount of radiation. In operation, at least one of the cascaded resonators is tuned by the control 901 to tune the spectral property of the overall filter. For example, the first resonator may be made of an electro-optic material to provide dynamic tuning to the filter 900 after the fabrication is completed and during the normal operation of the filter 900. Another resonator may be made of Ge-doped silica to allow for permanently tuning of the relative spectral properties of the resonators during the fabrication of the filter 900.

While this specification contains many specifics, these should not be construed as limitations on the scope of any invention or of what may be claimed, but rather as descriptions of features that may be specific to particular embodiments of particular inventions. Certain features that are described in this specification in the context of separate embodiments can also be implemented in combination in a single embodiment. Conversely, various features that are described in the context of a single embodiment can also be implemented in multiple embodiments separately or in any suitable subcombination. Moreover, although features may be described above as acting in certain combinations and even initially claimed as such, one or more features from a claimed combination can in some cases be excised from the combination, and the claimed combination may be directed to a subcombination or variation of a subcombination.

Only a few implementations are disclosed. However, it is understood that variations and enhancements may be made.

What is claimed is:

1. An optical device, comprising:

a whispering gallery mode (WGM) optical resonator configured to support one or more whispering gallery modes;

a photodetector optically coupled to an exterior surface of the optical resonator to receive evanescent light from the optical resonator to detect light inside the optical resonator; and

a spacer comprising a transparent material positioned between the photodetector and the exterior surface of the optical resonator, wherein the spacer is in direct physical contact with the exterior surface of the optical resonator and the photodetector.

2. The device as in claim 1, wherein the refractive index of the transparent material is less than (1) a refractive index of the optical resonator and (2) a refractive index of the photodetector.

3. The device as in claim 1, wherein the transparent material is a polymer.

4. The device as in claim 1, wherein the transparent material is coated on the photodetector.

5. The device as in claim 1, wherein the transparent material is coated on the exterior surface of the optical resonator.

6. The device as in claim 1, wherein the optical resonator is made of at least a part of a spheroid to support one or more whispering-gallery modes circulating along an equator in a circular cross section of said spheroid and around a short ellipsoid axis of said spheroid.

7. The device as in claim 1, wherein the optical resonator has a disk shape.

8. The device as in claim 1, wherein the optical resonator is made of at least a part of a sphere to support one or more whispering-gallery modes circulating along an equator.

9. The device as in claim 1, wherein the optical resonator includes an electro-optical material, and the device comprises a control unit to apply an electrical control signal to the optical resonator to tune a frequency of the optical resonator.

10. The device as in claim 9, wherein the optical resonator includes a lithium niobate crystal.

11. The device as in claim 1, comprising an optical coupler that is optically coupled to the optical resonator.

12. The device as in claim 11, wherein the optical coupler includes a waveguide.

13. The device as in claim 11, wherein the optical coupler includes a photonic bandgap material.

14. The device as in claim 11, wherein the optical coupler includes a prism.

- 15.** A device, comprising:
 first and second optical resonators each configured to support whispering gallery modes, wherein the first and said second optical resonators are optically coupled to each other to allow for light coupling from a first whispering gallery mode in the first optical resonator to a second whispering gallery mode in the second optical resonator;
 a first photodetector optically coupled to the first optical resonator to detect light in the first optical resonator;
 a first spacer comprising a transparent material positioned between the first photodetector and an exterior surface of the first optical resonator, wherein the first spacer is in direct physical contact with the exterior surface of the first optical resonator and the first photodetector;
 a second photodetector optically coupled to the second optical resonator to detect light in the second optical resonator; and
 a second spacer comprising a transparent material positioned between the second photodetector and an exterior surface of the second optical resonator, wherein the second spacer is in direct physical contact with the exterior surface of the second optical resonator and the second photodetector.
- 16.** The device as in claim **15**, wherein at least one of the first and said second optical resonators is tunable in response to a control signal.
- 17.** A method, comprising:
 placing a photodetector near an exterior surface of a whispering gallery mode (WGM) optical resonator to opti-

- cally couple the photodetector to an evanescent field of light in the optical resonator;
 placing a spacer comprising a transparent material positioned between the photodetector and the exterior surface of the first optical resonator, wherein the spacer is in direct physical contact with the exterior surface of the first optical resonator and the first photodetector; and
 using the photodetector to receive evanescent light from the optical resonator to detect light inside the optical resonator.
- 18.** The device as in claim **1**, wherein a thickness of the spacer is controlled to set a coupling strength between the photodetector and the optical resonator, and to adjust the Q factor of the one or more whispering gallery modes.
- 19.** The device as in claim **15**, wherein a thickness of the first spacer is controlled to set a coupling strength between the first photodetector and the first optical resonator, and to adjust the Q factor of the one or more whispering gallery modes; and wherein a thickness of the second spacer is controlled to set a coupling strength between the second photodetector and the second optical resonator, and to adjust the Q factor of the one or more whispering gallery modes.
- 20.** The method as in claim **17**, further comprising controlling a thickness of the spacer to set a coupling strength between the photodetector and the optical resonator, and to adjust the Q factor of the one or more whispering gallery modes.

* * * * *