



OLI Radiometric Calibration

- Brian Markham, NASA/GSFC, Ron Morfitt, SGT contractor to USGS, EROS
- Geir Kvaran, Ball Aerospace & Technologies Corp.
- Stuart Biggar, Nathan Leisso, Jeff Czapla-Myers, University of Arizona

NASA GSFC / USGS EROS

LDCM
LANDSAT



data continuity mission





Introduction and Overview



Goals

- Present an overview of the pre-launch radiance, reflectance & uniformity calibration of the Operational Land Imager (OLI)
 - ❖ Highlights topics of interest
 - Transfer to orbit/heliostat
 - Linearity
- Discuss on-orbit plans for radiance, reflectance and uniformity calibration of the OLI

Where we are at

- Flight radiometric characterization is complete (as of January 2011)
- Analysis completed with the exception of the final radiometric pre-launch rad calibration parameters

Notable aspects of our traceability approach include :

- Incorporation of a heliostat which allows a source based approach to visible calibration
- Use of FASCAL to calibrate the Small Spherical Source (SSS) at NIST provides an integrating sphere source as our on-site standard

Extensive characterization of the Death Star Source (DSS) from within the chamber

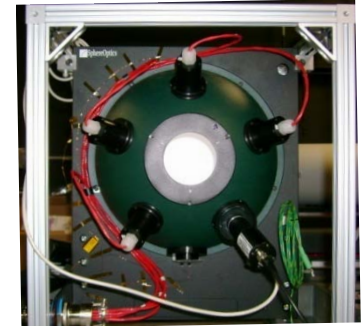

SSS

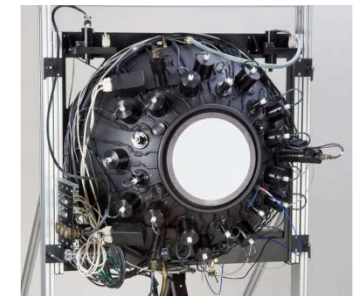

DSS

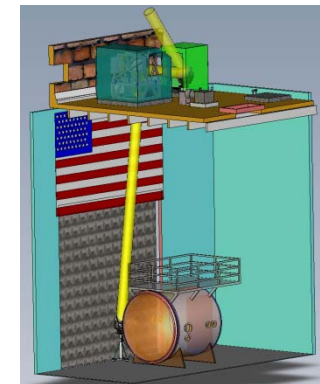

Heliostat

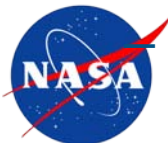



Driving Radiometric Requirements



- Reflectance and radiance traceable to NIST :

Parameter	Requirement (1-sigma)
Radiance	5%
Top of Atmosphere (TOA) Reflectance	3% of actual TOA

- “The Contractor shall provide an integrated instrument-level observation of at least one on-board calibration device that is radiometrically stable through launch”





Relative Radiometric Calibration (1 of 2)



- A.K.A. , Pixel-to-pixel non-uniformity
 - Within band, between detector variability after correction
 - Includes spectral component

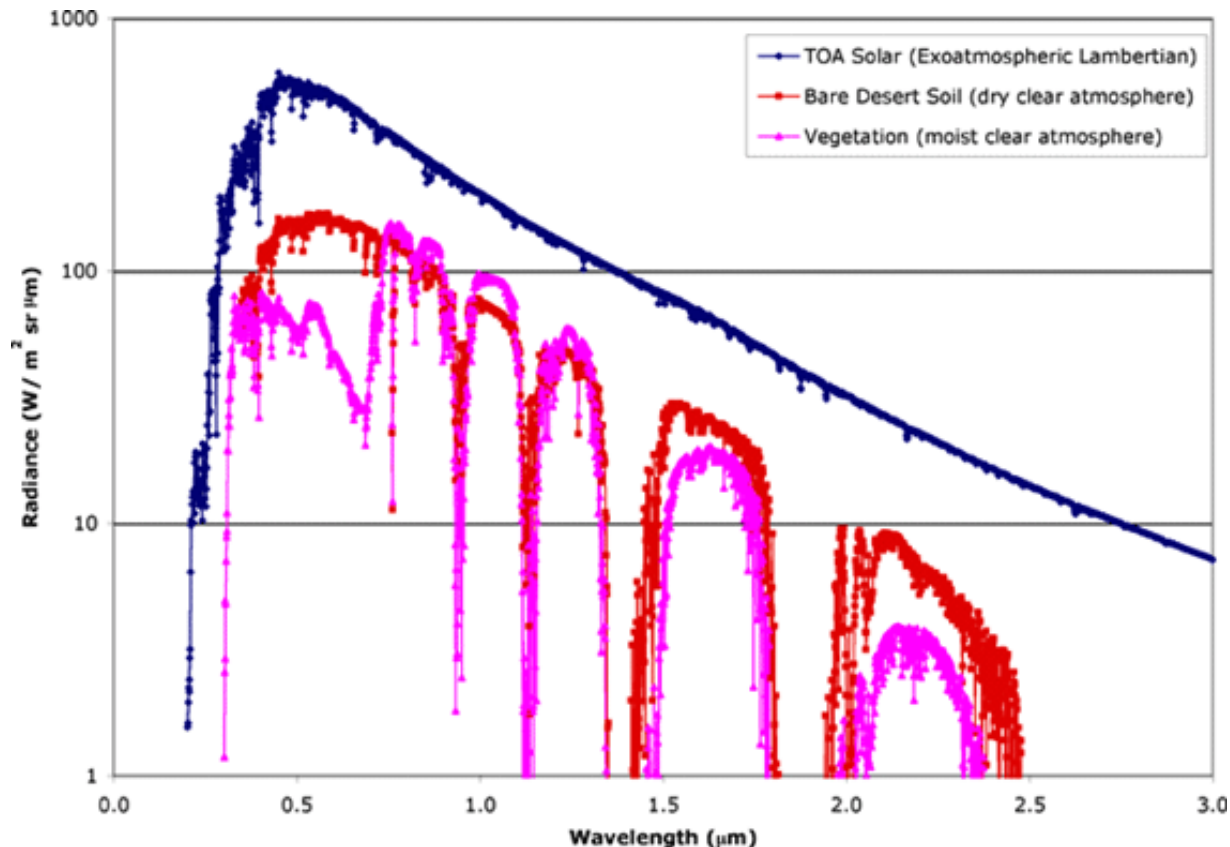



Relative Radiometric Calibration (2 of 2)



- Challenging for push broom instrument
 - 6000+ detectors/band
 - Multiple spectral filters per band / larger area of filters
- Requirements
 - Variation across full cross track swath -- 0.5 % (1 sigma)
 - Banding/Discontinuities
 - ❖ Variation across 100 pixel columns
 - 0.25 % (1 sigma)
 - ❖ RMS deviation from full swath mean
 - 1.0 % for 100 pixel columns
 - Streaking/Striping
 - ❖ Variation between adjacent pixel columns
 - 0.5 % maximum





Instrument Design as it Relates to Calibration



- Pushbroom, ~15 deg. field of view cross track, ~1.5 deg. In-track.
- Cooled HgCdTe focal plane require characterization in vacuum.
- Dual (working and pristine) Spectralon diffusers
- Entrance pupil is, forward, near entrance aperture.
- Calibration assembly contains a rotating diffuser wheel (green), shutter(yellow) , Earth and diffuser baffles(grey).
- Illumination of the diffusers requires active pointing by the spacecraft.
- Lamps available for daily trending of response through full system

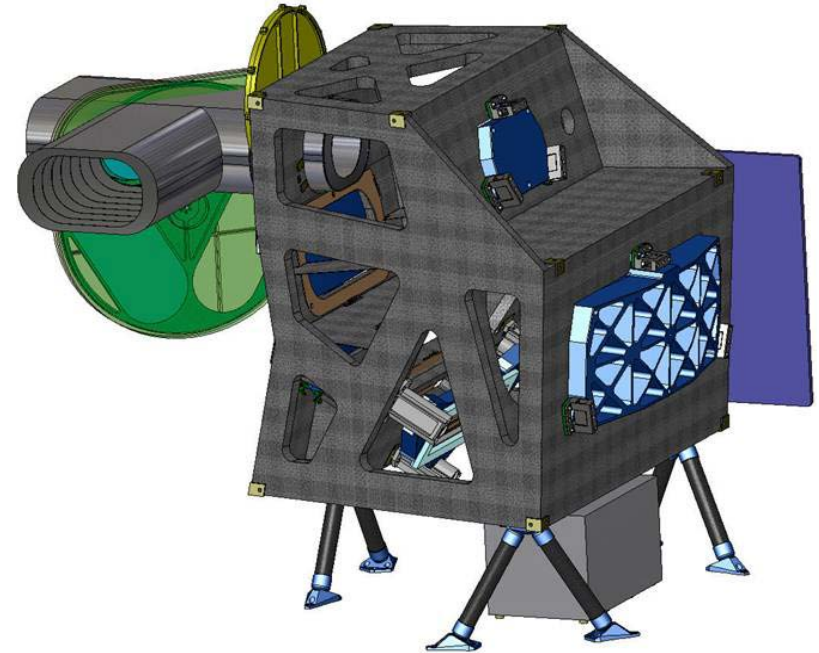

OLI





NIST Radiance Traceability Flow (Part 1) – NIST to Ball

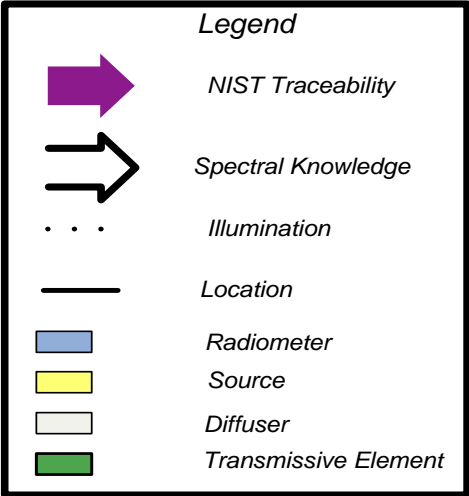

Sequence of Observations

- (1) Calibration of the Small Sphere Source (SSS) by FASCAL at NIST
- (2) Transport of the SSS from NIST to Ball w/observations by U of A radiometers and Ball Standard Radiometer (BSR)
- (3) Observation of the Calibration Transfer Radiometer (CXR) by the SSS at Ball

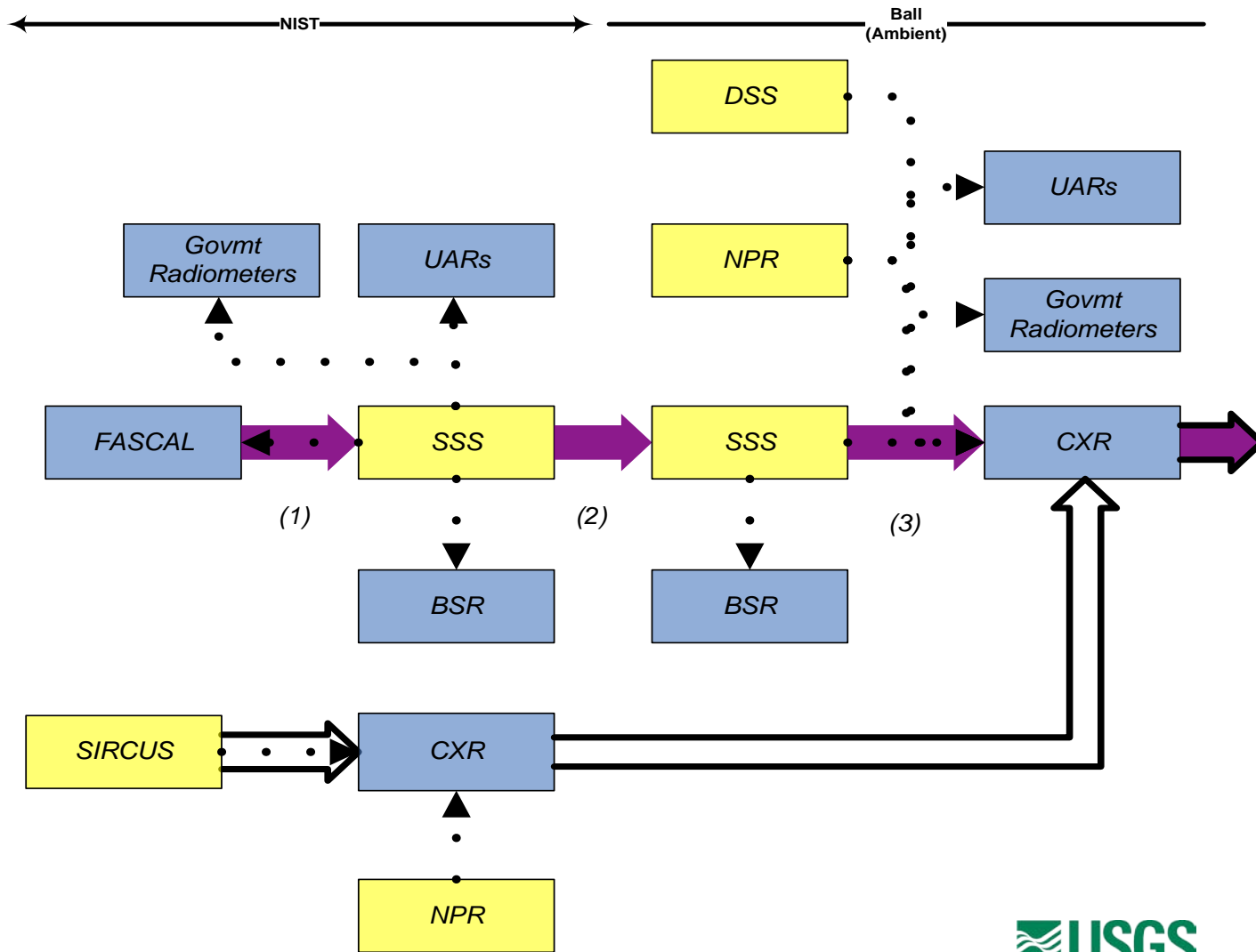



NIST Radiance Traceability Flow (Part 2) – Ball to On-Orbit

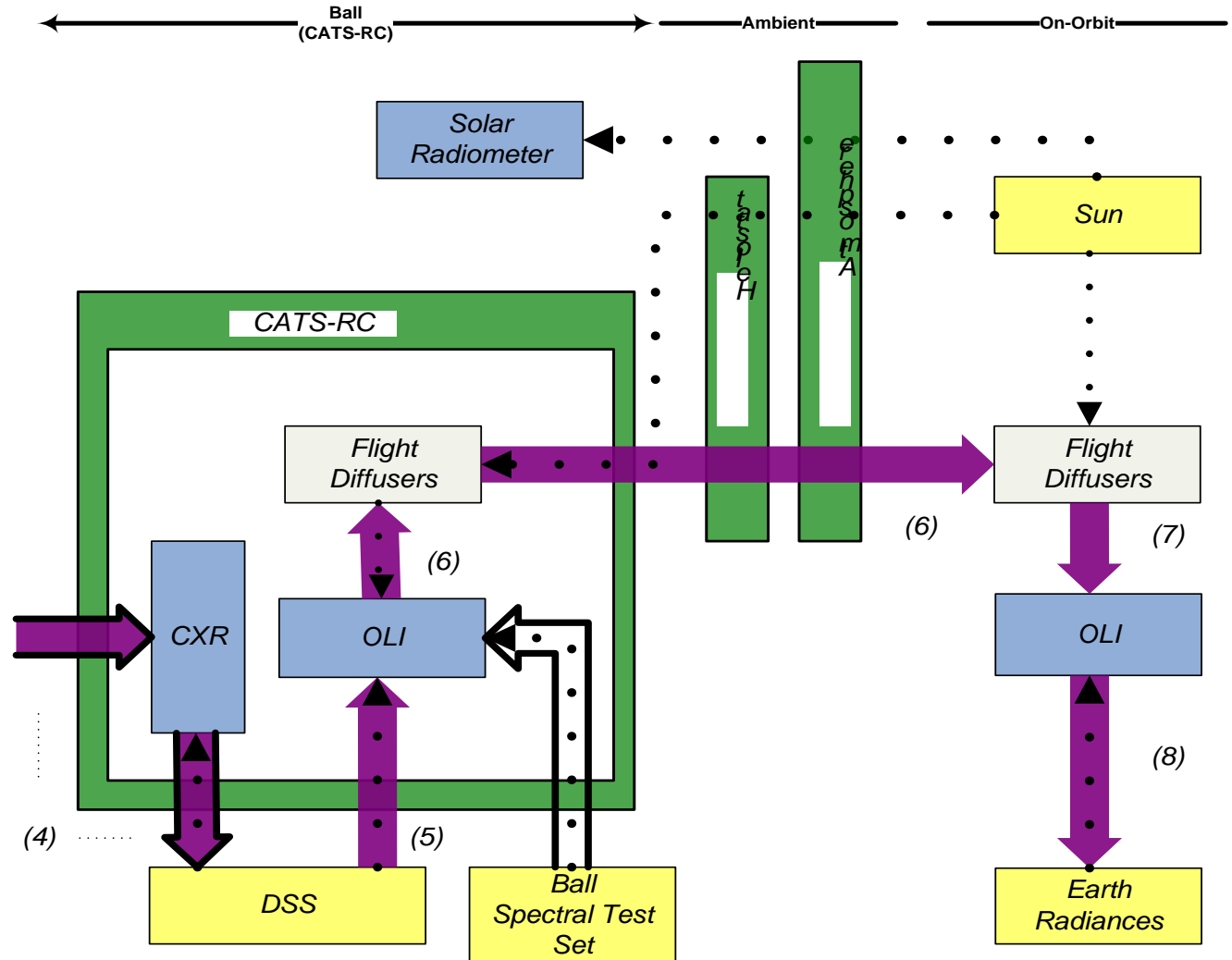
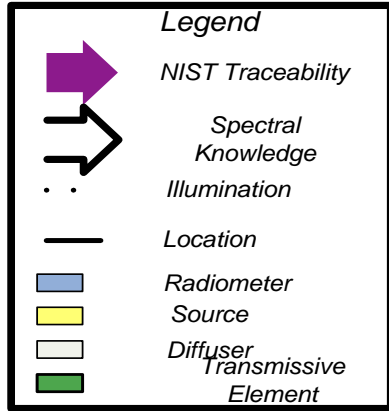

Sequence of Observations

- (4) Observation of the Death Star Source (DSS) by the CXR in the CATS-RC chamber.
- (5) Calibration of the solar illuminated flight diffusers with the heliostat in CATS-RC
- (6) Instrument at the S/C vendor & launch
- (7) Recalibration of the OLI by the solar illuminated diffuser on-orbit.
- (8) Observations of the Earth by the OLI

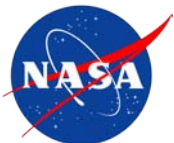



Radiance Uncertainty

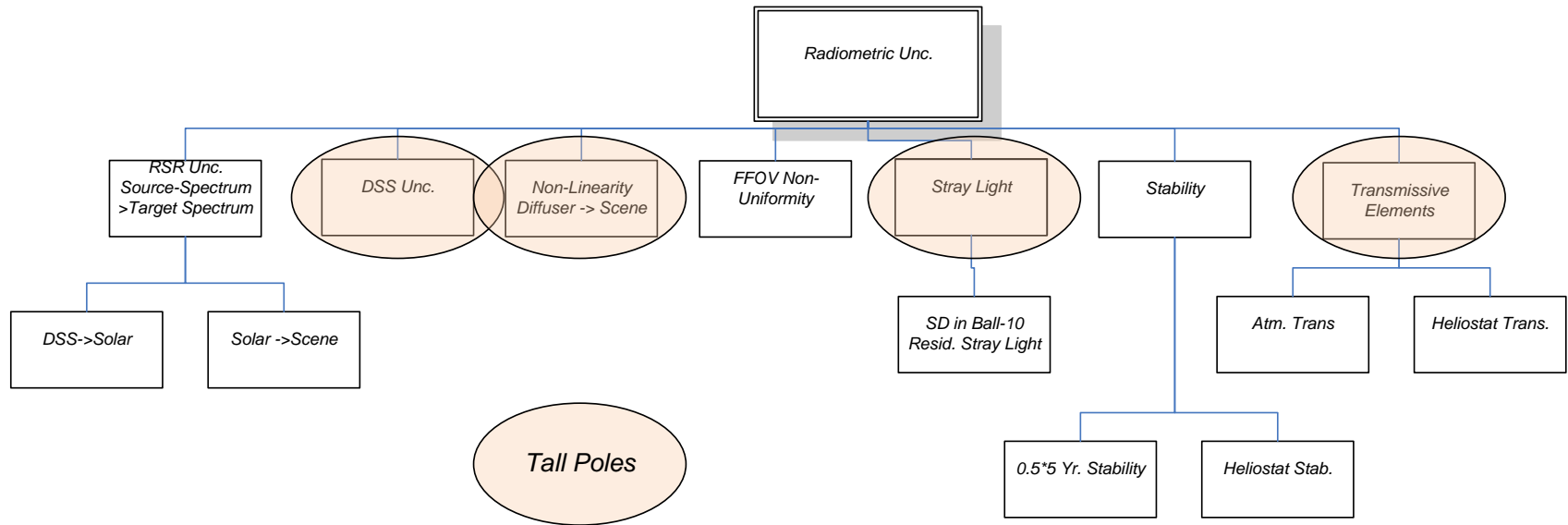

- < 3.5%, 1 σ End of Life
- Driving uncertainties:
 - Sphere uncertainty
 - Stray light
 - Heliostat transmission
 - Atmospheric transmission
 - Non-linearity

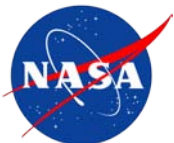



Reflectance Uncertainty

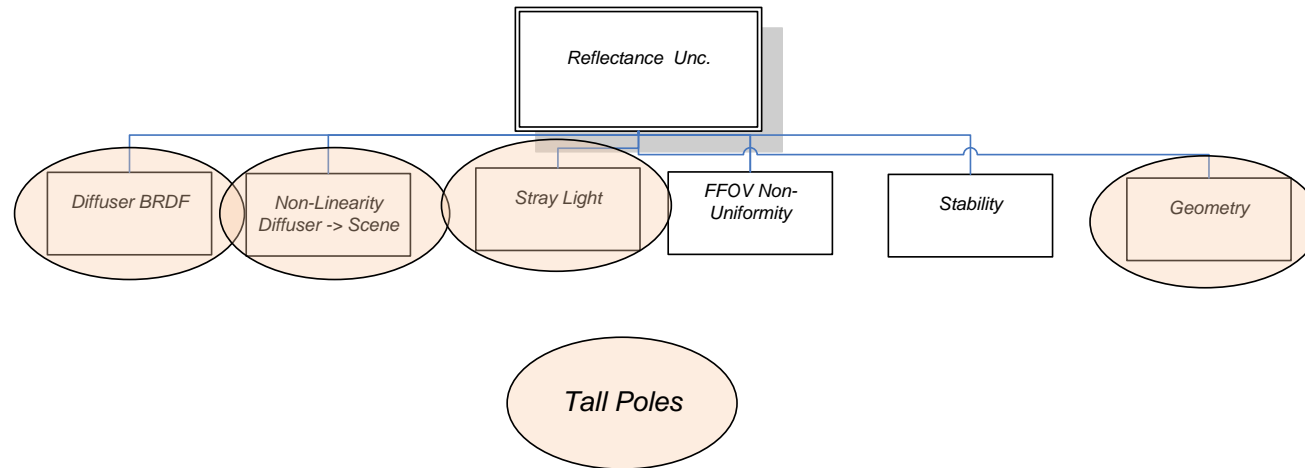

- < 2.5%, 1 σ End of Life
- Driving uncertainties:
 - Diffuser BRDF
 - Stray light
 - Stray Light
 - Non-linearity





Non-Uniformity



Data Sources

- Primary Sphere Collect (CATS-RC)
- Stability Collects (CATS-RC)
- Heliostat Image Collects (CATS-RC)
- In-band Spectral (CATS-RC)
- Out Of Band Spectral (DTC)
- Heliostat Characterization
- DSS Characterization

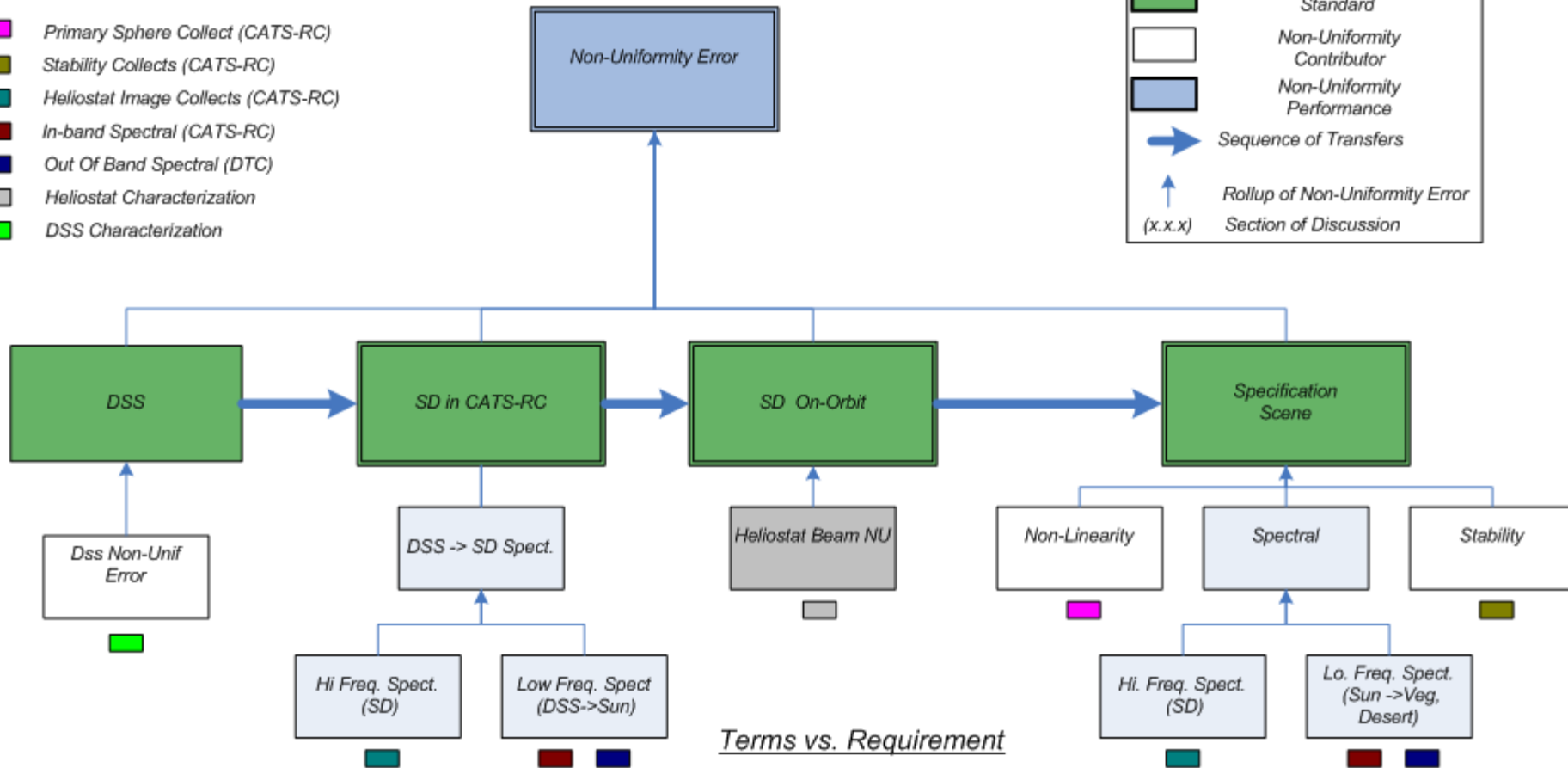
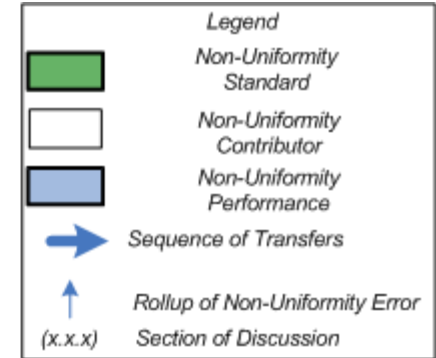

Terms vs. Requirement

- Applies to All Rqmts
- Applies to FFOV Only
- Applies to All Rqmts Except for Cirrus





Characterization of the DSS Non-Uniformity With OLI



- Images are NU maps of the DSS acquired by OLI in the T/V chamber.
- To acquire data we stepped the stage in 0.1 degree increments over +/-1 degree in az/el.
- This gives an in-situ & 'as-used' uniformity characterization of the DSS NU
- Blue stripes are the FOV of each of the 14 focal plane modules.
- Separation of odd/even FPM is real.
- This set of images required ~ 24 hours to collect.

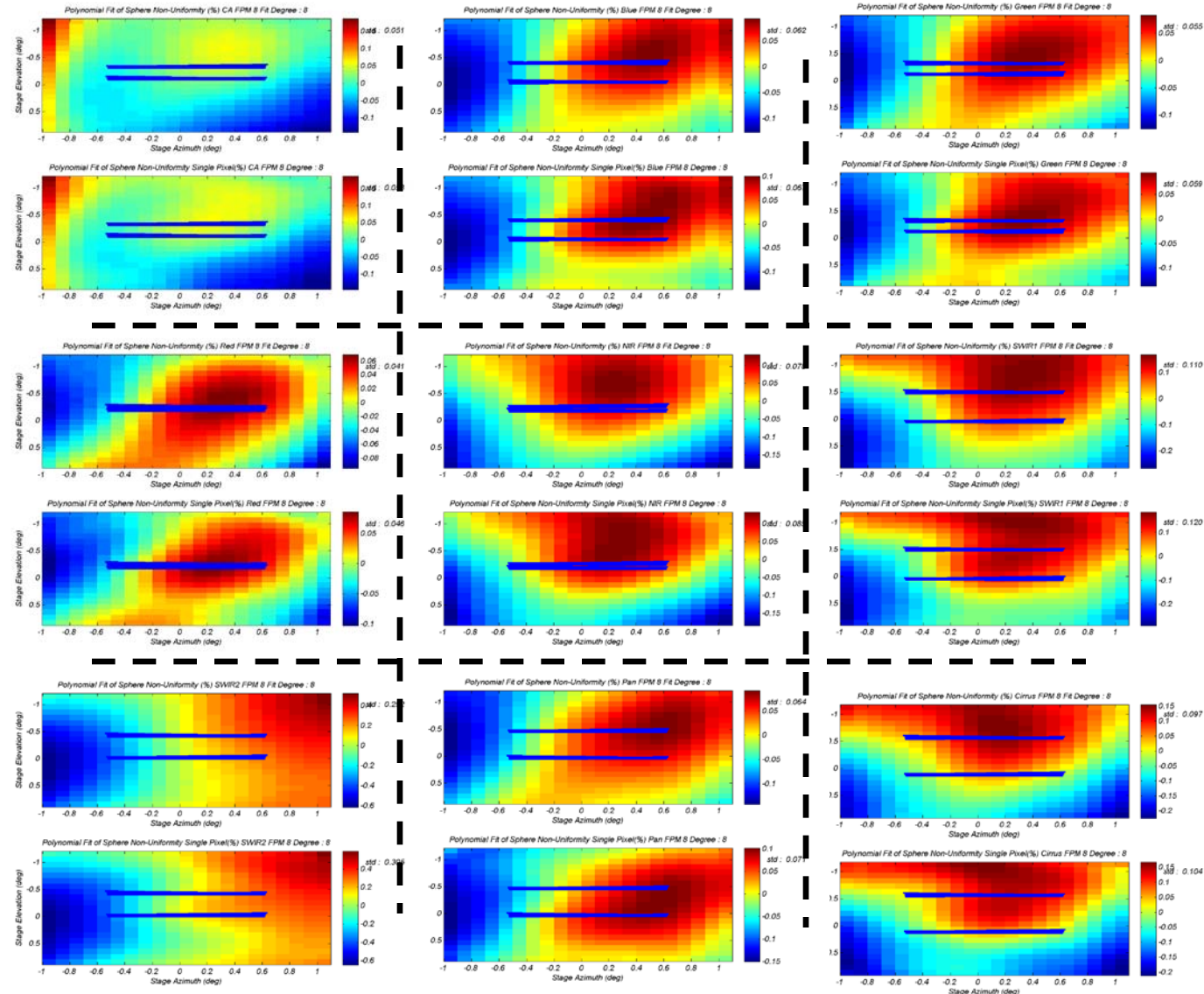



Stray Light



- There are two potential stray light issues relevant to the OLI calibration
 - Stray light in the observation of the DSS
 - Stray light in the diffuser observation
- During EDU testing we identified a significant source of stray light in the sphere observations, a retro-reflection from the inside of the chamber window
 - This produced a non-uniformity on the order of 1%
 - We were able to model this ghost and show that tilting the chamber window would redirect the ghost energy out of the sensor FOV.
- Stray light modeling indicated two significant sources of stray light in the diffuser observations:
 - A non-uniform ghost due to reflections from the diffuser baffle
 - Scattered light due to anticipated levels of contamination on the chamber window
 - We correct for $\frac{1}{2}$ the magnitude of both error sources and book-keep a 1σ error of $\frac{1}{2}$ the magnitude.





Non-Linearity



- We estimated non-linearity by varying the DSS radiance and by varying the integration time.
- This data shows adequate agreement (~1%) for an integration time based correction that satisfies the OLI needs
 - More work can be done on algorithms.
- This means we have a useful characterization of non-linearity on-orbit.
 - We will observe the diffuser at 21 integration times every month as part of the operations concept.

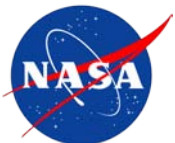
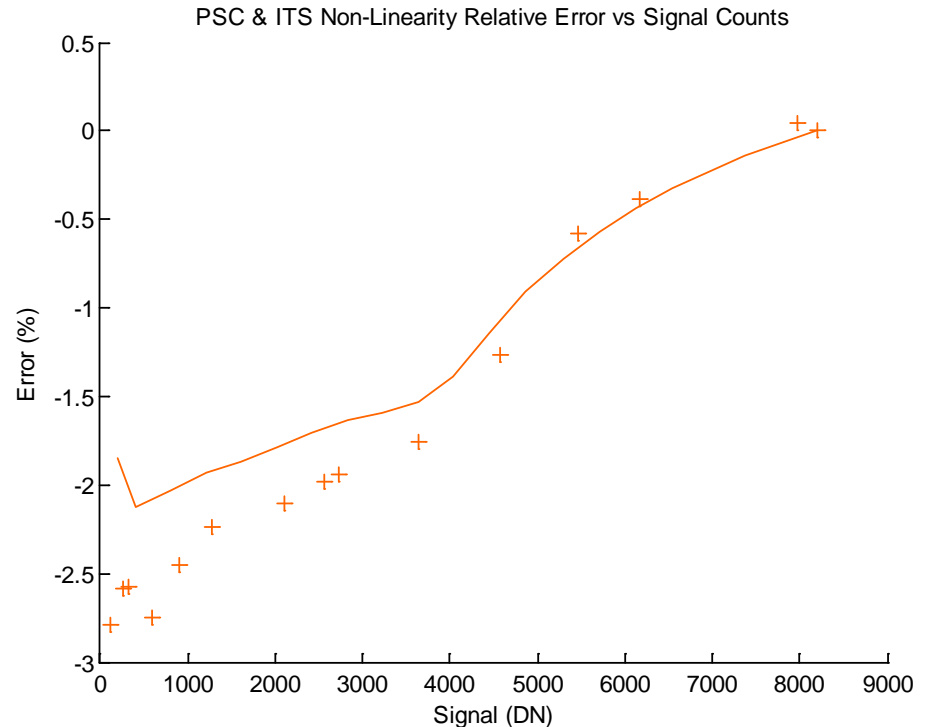



BRDF Traceability



- Our reference was a diffuse panel characterized by NIST over all OLI wavelengths.
- OLI is the first flight program to utilize the STARR SWIR capabilities
- The flight panel BRDF's were extensively characterized using the U of A BRDF facility as a transfer reflectometer.

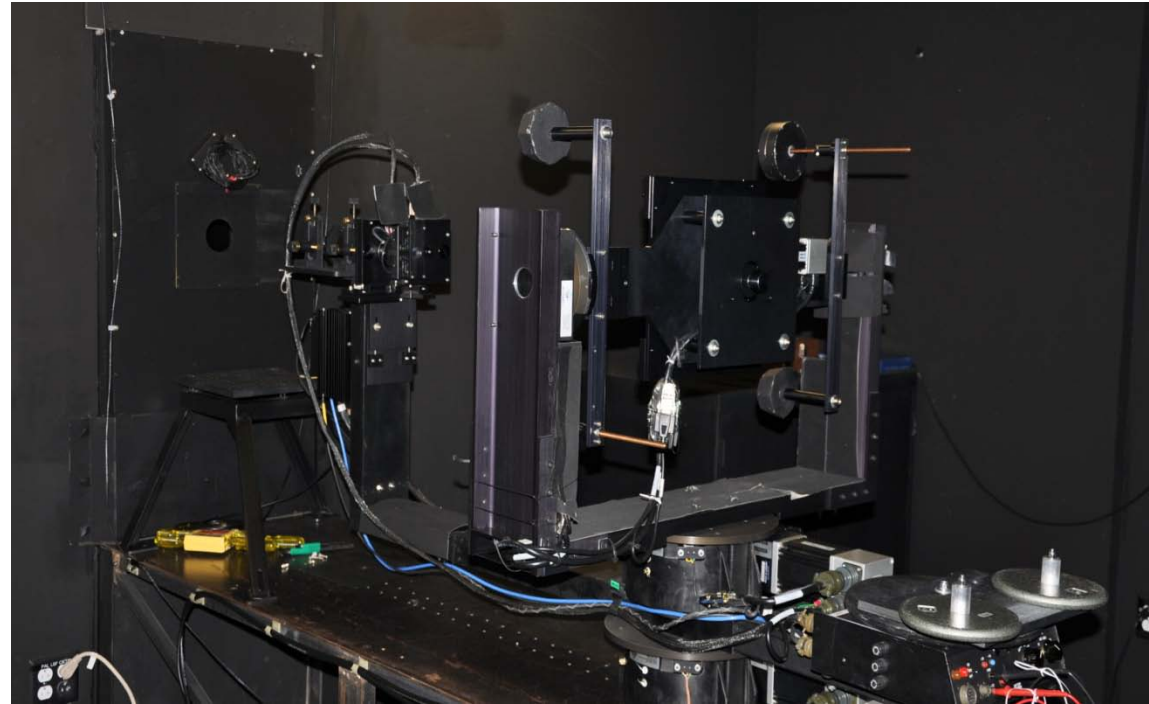



Applying the on-line calibration to diffuser observations gives estimates of the diffuser



- What is the source of the left to right variation in the diffuser?

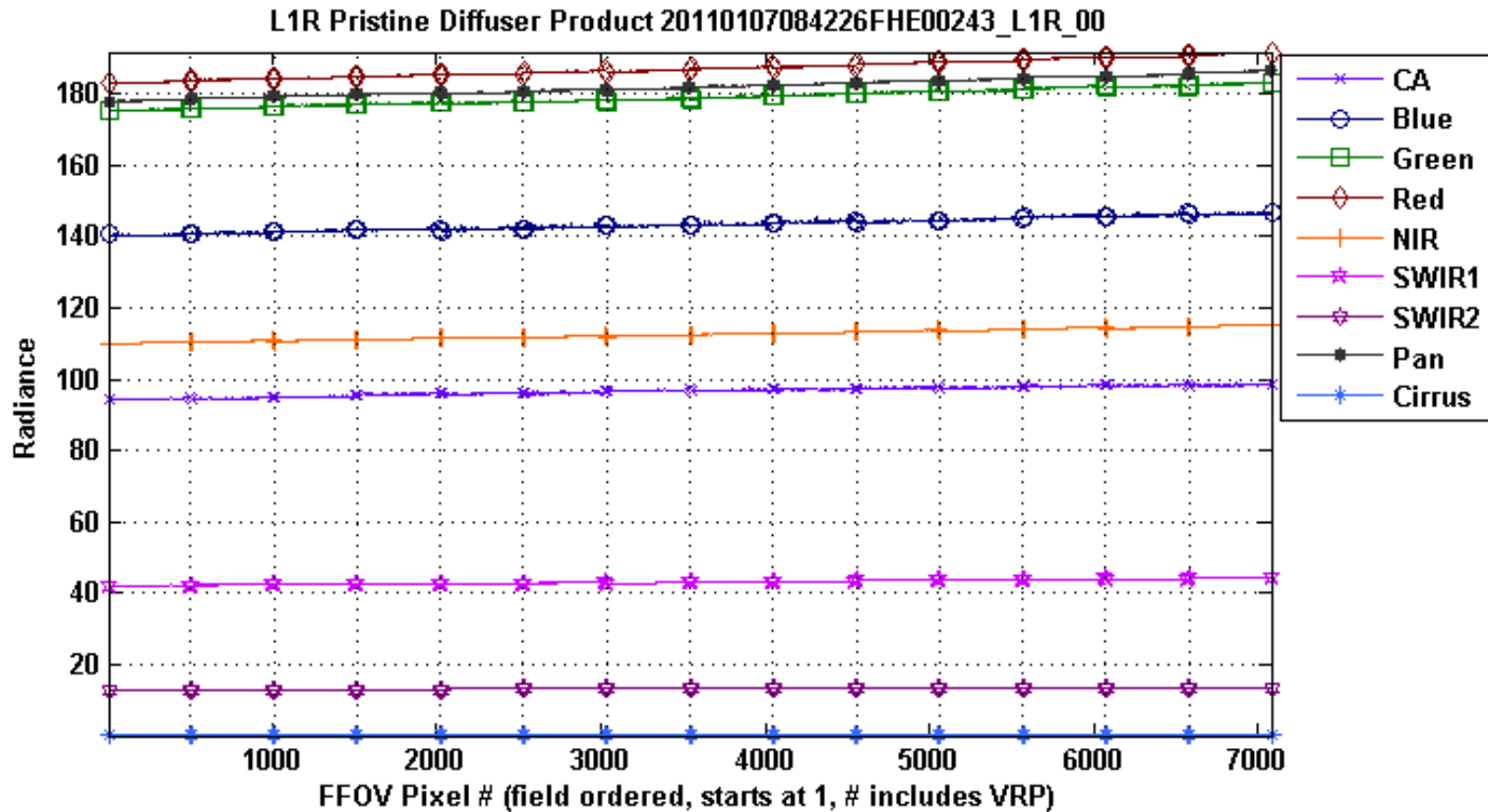



Measured diffuser radiance corresponds well with diffuser BRDF

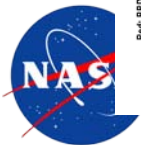
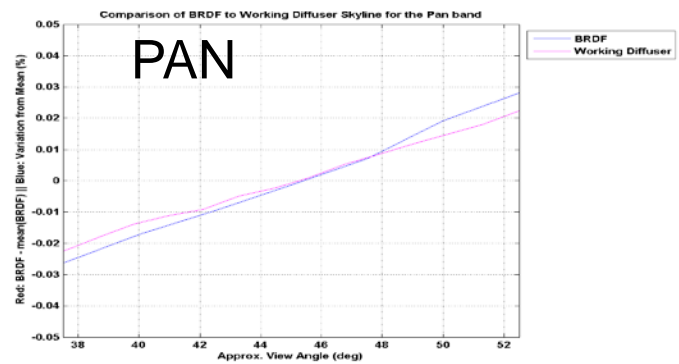
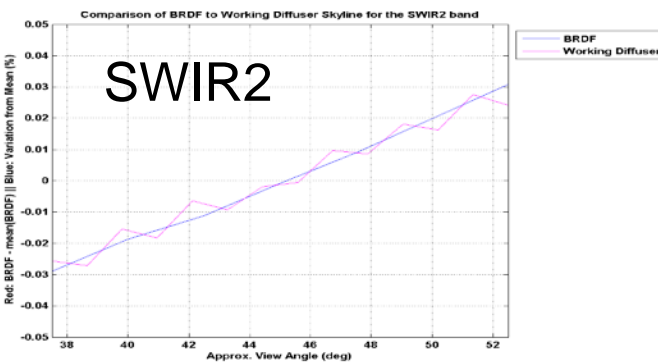
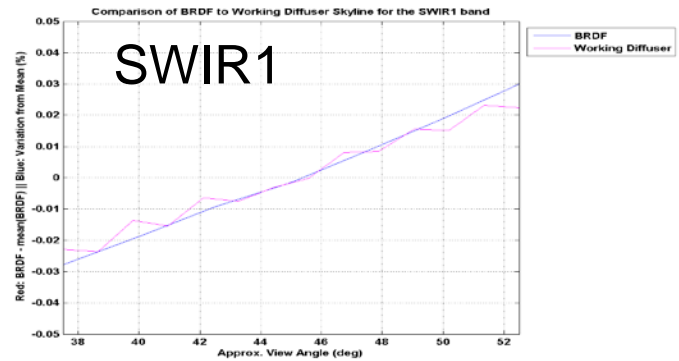
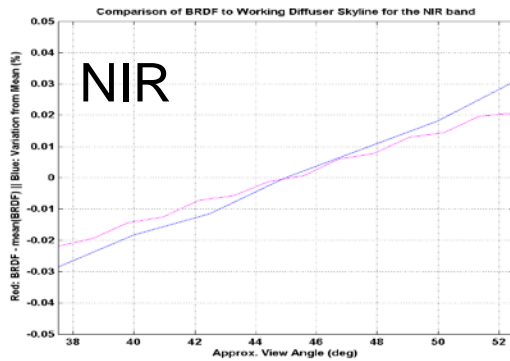
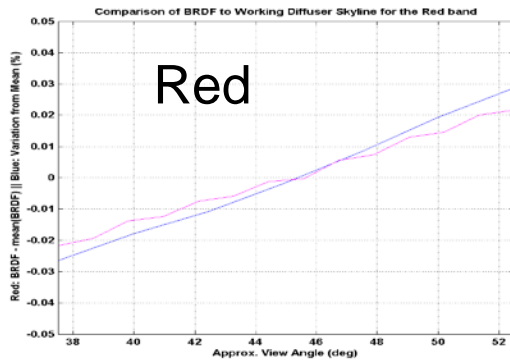
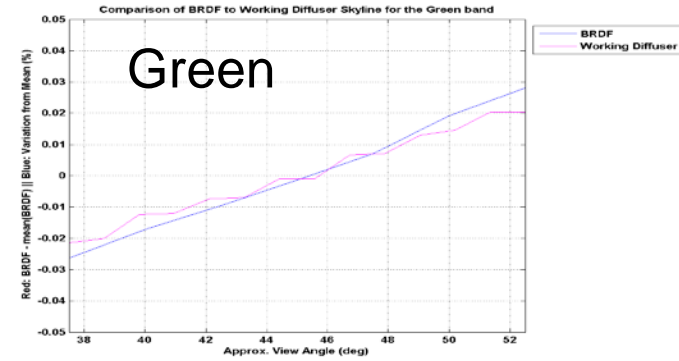
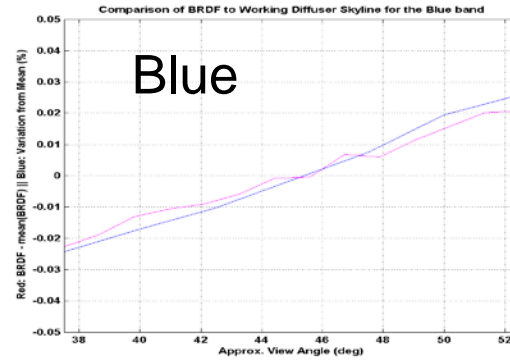
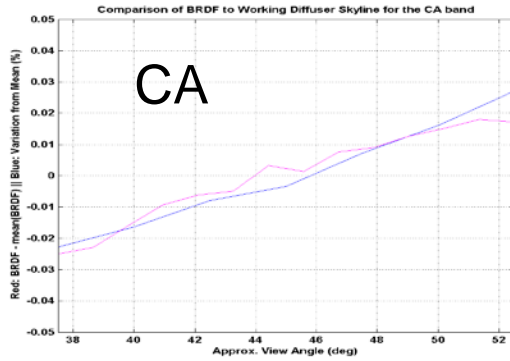



Heliostat Observations

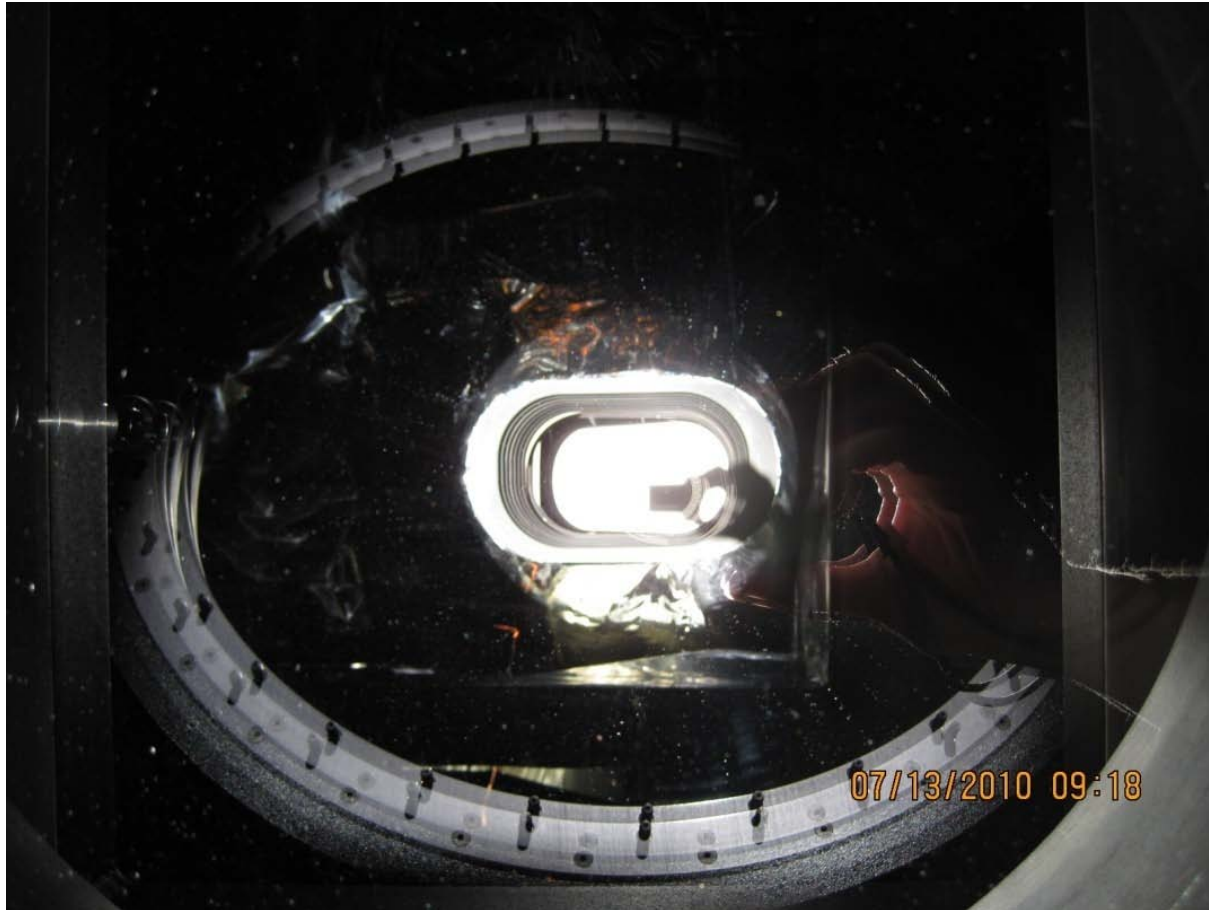

- After correction for transmission of the heliostat and atmosphere, we have characterized the radiance of the diffuser as it will be on-orbit.

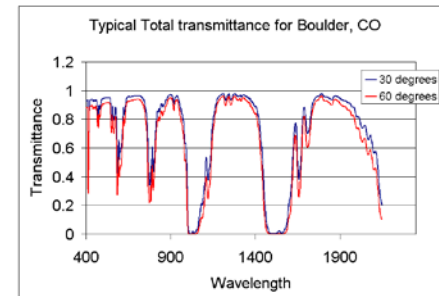



Measured Heliostat Transmission

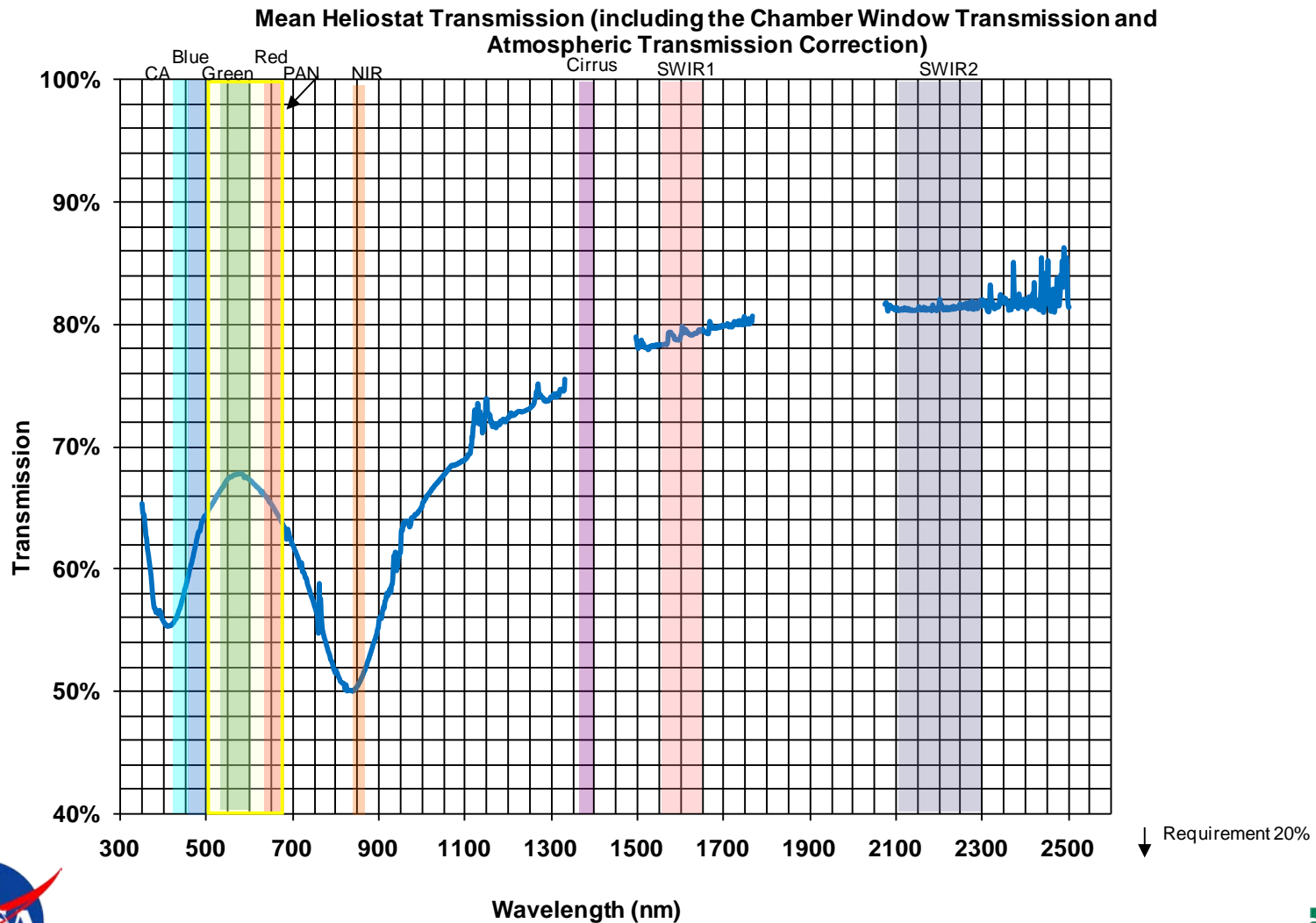



Predicting diffuser on-orbit radiances gives good agreement in the Si bands



$$L_{\lambda,SD,TOA,2} = \cos(45) \frac{\int R(\lambda) E_{\lambda, Sun, Thelio, 2}(\lambda) d\lambda RF(45, 180; 45, 0)}{\int R(\lambda) d\lambda} \pi$$

Method 3

$$L_{\lambda,SD,TOA,3} = (D_{E-S})^2 \frac{L_{\lambda,SD,BOA}}{\tau_{thelio} \tau_{thelio}}$$

Method 2

OLI Band	TOA Rad
CA	467.28
B	502.25
G	455.04
R	387.71
NIR	238.79
SW1	
SW2	
P	431.15
CRS	92.25

Measured Working Diffuser Spectral Radiance at 1 A.U. = DiffRad ./ Tatm ./ Thelio ./ (1/Esdist^2)									
OLI Band	Col. #1	Col. #2	Col. #3	Col. #4	Col. #5	Col. #6	Col. #7	Col. #8	Col. #8
CA	479.95	478.96	476.55	477.41	475.79	476.82	473.49	475.49	475.49
B	489.23	487.89	486.96	487.40	484.93	486.21	483.11	484.30	484.30
G	454.78	453.91	455.23	456.20	453.56	455.29	452.96	453.98	453.98
R	388.41	387.96	389.51	390.80	388.61	390.13	388.65	389.42	389.42
NIR	232.28	232.58	233.25	234.32	233.20	234.21	233.58	234.06	234.06
SW1									
SW2									
P	428.80	428.11	429.46	430.54	428.08	429.72	427.67	428.60	428.60
CRS	NaN	NaN	NaN	NaN	NaN	NaN	NaN	NaN	NaN

% Difference between Method 2 and Method 3

% Difference of Measured and Predicted Diffuser Spectral Radiance at TOA										
OLI Band	Col. #1	Col. #2	Col. #3	Col. #4	Col. #5	Col. #6	Col. #7	Col. #8	Mean	CV
CA	2.64%	2.44%	1.95%	2.12%	1.79%	2.00%	1.31%	1.73%	2.00%	0.42%
B	-2.66%	-2.94%	-3.14%	-3.05%	-3.57%	-3.30%	-3.96%	-3.71%	-3.29%	0.43%
G	-0.06%	-0.25%	0.04%	0.25%	-0.33%	0.05%	-0.46%	-0.23%	-0.12%	0.24%
R	0.18%	0.06%	0.46%	0.79%	0.23%	0.62%	0.24%	0.44%	0.38%	0.24%
NIR	-2.80%	-2.67%	-2.37%	-1.91%	-2.40%	-1.96%	-2.23%	-2.02%	-2.29%	0.33%
SW1										
SW2										
P	-0.55%	-0.71%	-0.39%	-0.14%	-0.72%	-0.33%	-0.81%	-0.60%	-0.53%	0.23%
CRS	NaN	NaN	NaN	NaN	NaN	NaN	NaN	NaN	NaN	NaN





On-Orbit Radiometric Calibrations



- **Detector-to-Detector relative calibration (uses solar diffusers, overlap statistics, side slither, scene statistic characterizations)**
- **Absolute calibration (use solar diffusers, moon, vicarious, lamps)**
 - Radiance
 - ❖ Baseline uses working solar diffuser ~ weekly; pristine solar diffuser ~ twice yearly; predicted diffuser radiance from pre-launch heliostat and transfer to orbit calculations
 - ❖ Checks available
 - instrument radiance calibration stable through launch
 - Diffuser reflectance and solar irradiance curves, e.g. Thullier
 - Vicarious calibrations (two sites, minimum 4 times/year)
 - Cross calibrations (Landsat, Sentinel-2, etc)
 - Reflectance
 - ❖ Uses pre-launch measured diffuser BRDF
 - Stability monitoring
 - ❖ Redundant diffusers
 - ❖ Moon every month near full phase
 - ❖ Lamps: working – daily, pristine ~twice yearly
 - ❖ Pseudo-invariant sites (PICS)
- **Response Non-linearity calibration (use integration time sweeps)**
- **Bias determination (use shutter data, VRP's)**





Conclusions



- The details of the OLI Calibration plan have been strongly impacted by the specifics of the radiometric requirements.
 - The addition of the transfer to orbit requirement has significantly effected our calibration plan and will result in a chain of traceability from pre-launch to the on-orbit environment.
- The OLI instrument and program are well situated to carry on the Landsat radiometric calibration heritage.

OLI Calibration Working Group

Team Member	Role
GSFC	Oversight, Landsat/ALI heritage
Ball Aerospace	Instrument design, integration & test, algorithm development
Celestial Reasonings	Lunar observations, review
University of Arizona	NIST traceability, transfer to orbit, review
EROS	Algorithm development, implementationn of operational algorithms
SDSU	Characterizations (esp. image based), Landsat and ALI heritage





Results - Transect Plots Show the Effect of DSS Non-Uniformity on OLI Non-Uniformity



- There plots are the inputs to the non-uniformity analysis.
- The impact on sphere uniformity is acceptable in all bands except SWIR2 where Banding (0.25%) is undesirable.
- In future we would optimize odd/even overlap for all bands.

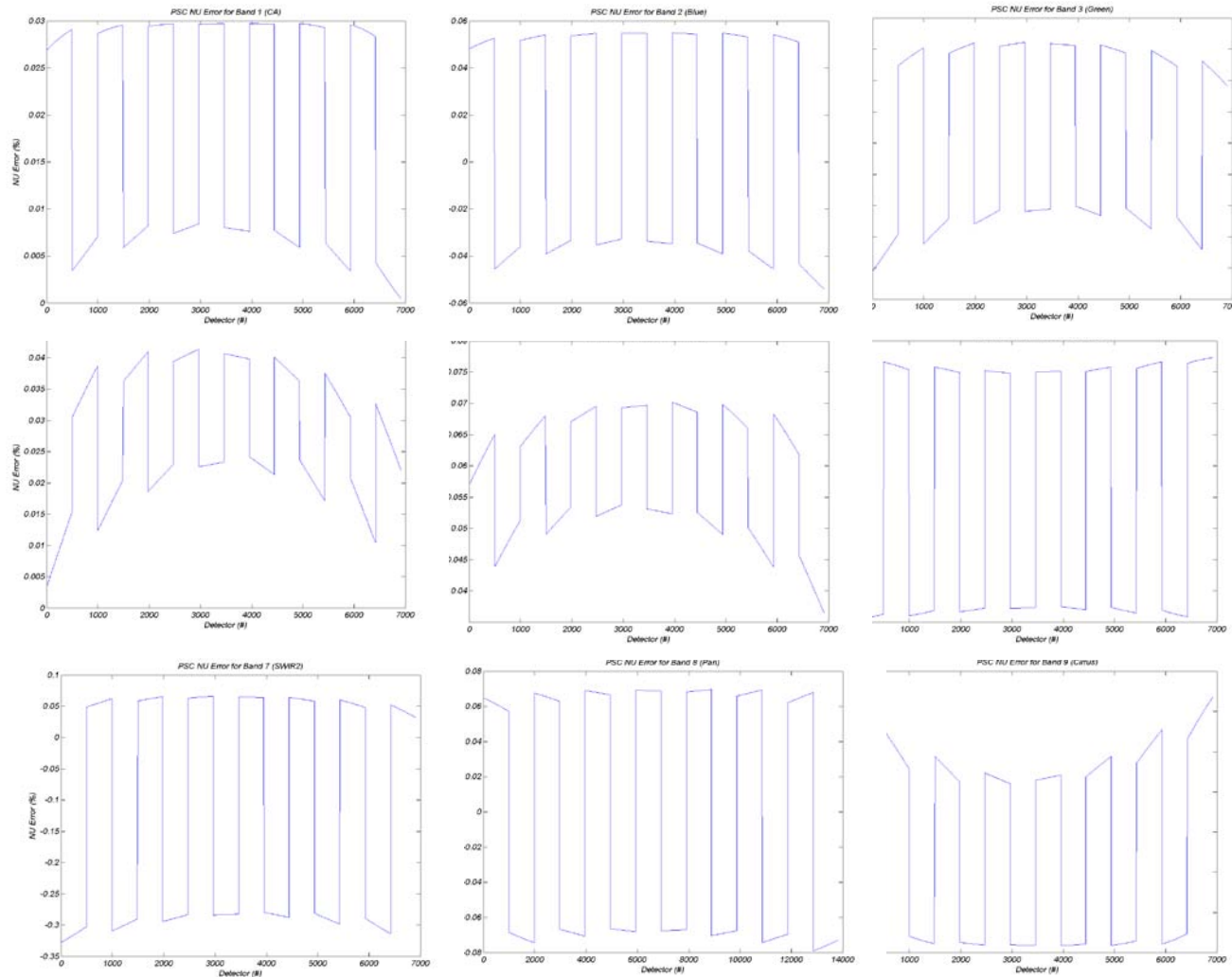

Band #	FFOV NU #	Banding #	Streaking #
1	0.05%	0.01%	0.01%
2	0.06%	0.05%	0.05%
3	0.05%	0.03%	0.03%
4	0.04%	0.01%	0.01%
5	0.08%	0.01%	0.01%
6	0.11%	0.08%	0.08%
7	0.29%	0.19%	0.19%
8	0.06%	0.07%	0.07%
9	0.10%	0.03%	0.03%

