

High-Fidelity Piezoelectric Audio Device

The same device can generate sound or tactile, inaudible vibrations.

Langley Research Center, Hampton, Virginia

ModalMax is a very innovative means of harnessing the vibration of a piezoelectric actuator to produce an energy efficient low-profile device with high-bandwidth high-fidelity audio response. The piezoelectric audio device outperforms many commercially avail-

able speakers made using speaker cones. The piezoelectric device weighs substantially less (4 g) than the speaker cones which use magnets (10 g). ModalMax devices have extreme fabrication simplicity. The entire audio device is fabricated by lamination. The simplicity of the design lends itself to lower cost. The piezoelectric audio device can be used without its acoustic chambers and thereby resulting in a very low thickness of 0.023 in. (0.58 mm). The piezoelectric audio device can be completely encapsulated, which makes it very attractive for use in wet environments. Encapsulation does not significantly alter the audio response. Its small size (see Figure 1) is applica-

ble to many consumer electronic products, such as pagers, portable radios, headphones, laptop computers, computer monitors, toys, and electronic games. The audio device can also be used in automobile or aircraft sound systems.

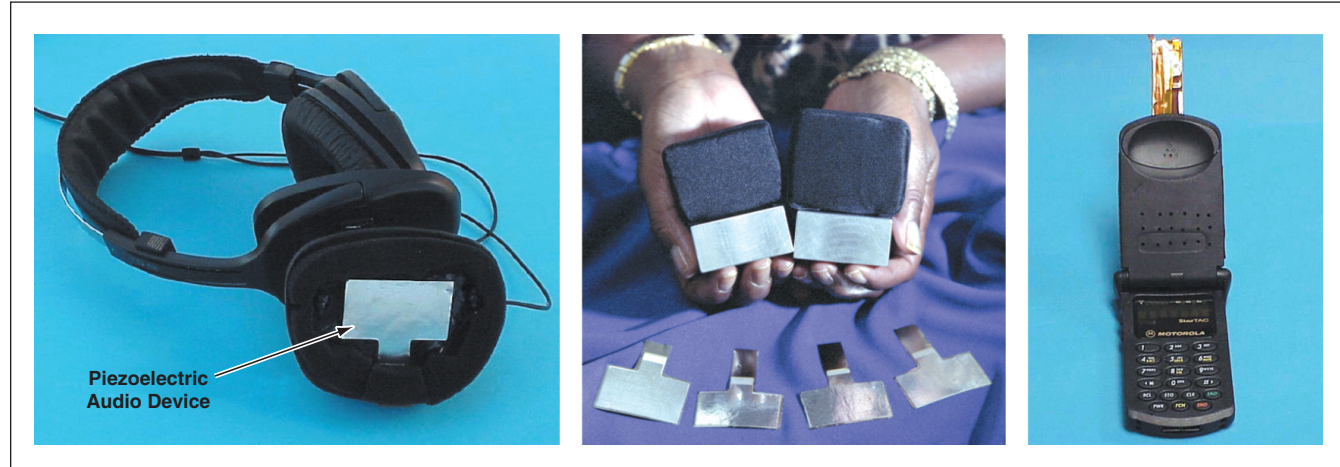

Figure 1. Piezoelectric Audio Devices can be mounted in headphones, used as speakers, and used inside a cell phone.

ble to many consumer electronic products, such as pagers, portable radios, headphones, laptop computers, computer monitors, toys, and electronic games. The audio device can also be used in automobile or aircraft sound systems.

The result of using the ModalMax techniques is a piezoelectric audio device with the audio response shown in Figure 2. At 1 cm (sufficient distance for headphones use), the response is 93 ± 5 dB for 600–5,000 Hz, (± 4 dB for response greater than 1 kHz). The de-

vice impedance decreases with frequency (3,500 ohms at 100 Hz, 83 ohms at 5 kHz and 43 ohms at 10 kHz). ModalMax consists of four methods used to produce high-quality sound from a piezoelectric actuator.

- *Mapping Vibration Topography* is the first method used to enhance audio output of piezoelectric devices. During vibration, the cyclic surface deformation produces out-of-plane displacements, the reciprocating strokes of which are similar to a piston. Deformation topography that occurs during vibration is measured using a laser vibrometer. The topography is used to identify all out-of-plane displacement lines and points having amplitudes sufficient for driving acoustic devices.
- *Tailoring Vibration Response* is the second method used to enhance piezoelectric audio output. The center photo in Figure 1 shows a piezoelectric actuator that has been developed to have numerous natural frequencies with high out-of-plane displacement amplitudes. The device has a "T" planform (i.e., throat and crossbar). The throat has a low torsion and bending stiffness; yet, can sustain

from the mounting line. The out-of-plane displacements for the 743 Hz and 426 Hz natural frequencies exceed 0.03 in. (0.76 mm). The displacement at the 977 Hz natural frequency can be seen with the naked eye.

- *Tailoring Damping Distribution* is the third method used and consists of strategically locating damping material on the piezoelectric device. The damping material makes the audio response quickly decay after a stimulus is removed. Eliminating persistent vibration reduces audio distortion. The complete audio response decays in approximately 3.7 ms.
- *Applying Acoustic Chambers* to one or more out-of-plane displacement lines identified from mapping is the fourth method of enhancing audio output. Locating multiple chambers on the piezoelectric-device surface makes it possible for a single actuator to drive numerous sound sources. Typical audio devices use a single driver (e.g., speaker cone driven by magnet) to produce a single sound source. Each acoustic chamber is formed as a cylinder with its bottom surface removed. The top surface has an orifice. When affixed to the

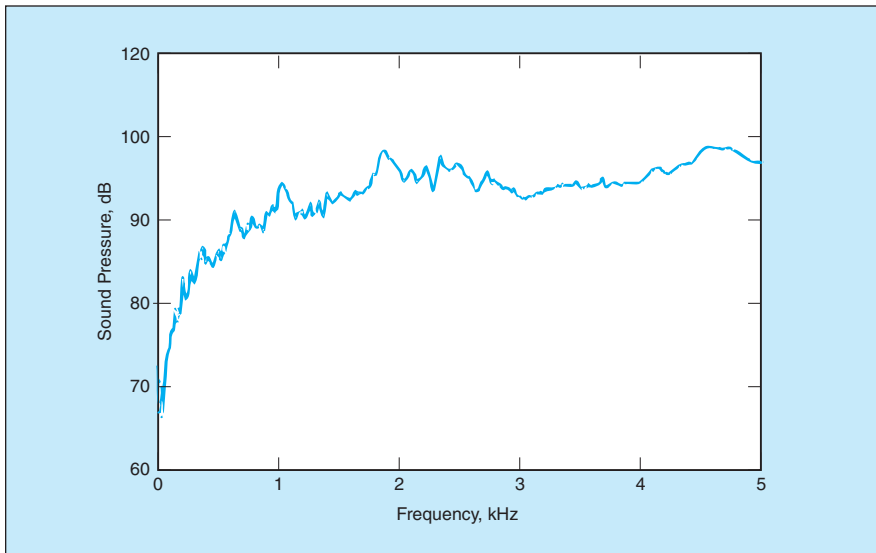

Figure 2. An **Audio Response** is shown for a piezoelectric-audio-device sound-pressure level measured at 1 cm without any sound enclosure using ± 14 V.

surface of the piezoelectric actuator, a resonating chamber similar to a Helmholtz chamber is formed.

*This work was done by Stanley E. Woodard, Robert L. Fox, and Robert G. Bryant of **Langley Research Center**. For further information, write to R. P. Turcotte, NASA Langley Research Center: postal address 3 Langley Boulevard, Mail Stop 200, Hampton, VA 23681-2199; telephone (757) 864-8881; fax (757) 864-8314; e-mail address r.p.turcotte@larc.nasa.gov.*

This invention is owned by NASA, and a patent application has been filed. Inquiries concerning nonexclusive or exclusive license for its commercial development should be addressed to the Patent Counsel, Langley Research Center; (757) 864-3521. Refer to LAR-15959.

Photovoltaic Power Station With Ultracapacitors for Storage

Ultracapacitors offer advantages over batteries in this application.

John H. Glenn Research Center, Cleveland, Ohio

The figure depicts a solar photovoltaic power station in which ultracapacitors, rather than batteries, are used to store energy. Developments in the semiconductor industry have reduced the cost and increased the attainable efficiency of commercially available photovoltaic panels; as a result, photovoltaic generation of power for diverse applications has become practical. Photovoltaic generation can provide electric power in remote locations where electric power would otherwise not be available. Photovoltaic generation can also afford independence from utility systems. Applications include supplying power to scientific instruments and medical equipment in isolated geographical regions.

The reasons for choosing ultracapacitors instead of batteries in this power station are the following:

- Batteries are not particularly suitable for storing energy generated in photovoltaic power systems. Batteries must be kept adequately charged, and are not permitted to be completely discharged. The variability of available sunlight makes it difficult to satisfy this requirement.
- Batteries must be sized to accommodate peak load currents, which are usually much greater than average load currents.

- Batteries have rather short cycle lives and their internal chemical reactions cause deterioration over time.
- Batteries perform poorly at low temperatures.
- Ultracapacitors make it possible to overcome most of the aforementioned disadvantages of batteries.

The ultracapacitors in this power station are electrochemical units. Because these capacitors contain large-surface-area electrodes with very small interelectrode gaps, they have large volumetric capacitances. Capacitors can have cycle lives that are extremely long, relative to those of batteries; indeed, it may never become necessary to replace capacitors. The longevity of capacitors increases reliability, reduces

life-of-system costs, and reduces adverse environmental effects. The longevity of capacitors is especially desirable for photovoltaic power systems, which are kept in service continuously for many years.

The power densities of capacitors exceed those of batteries. Therefore, high power can be drawn as needed and then capacitors can be recharged very quickly in preparation for the next high power demand. Capacitors have excellent low-temperature characteristics, continue to function without need for maintenance, and perform consistently over time. In addition, capacitors are conducive to safety in that it is easy to discharge them and they can be left completely discharged.

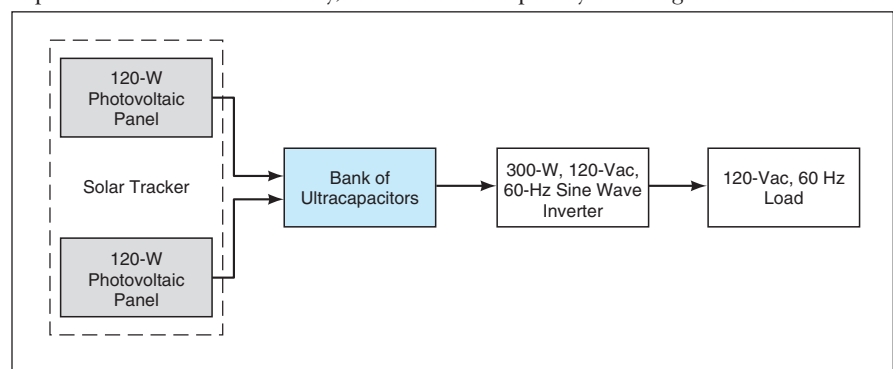

This **Photovoltaic Power Station** utilizes ultracapacitors (instead of batteries) as energy-storage devices.