

## Tool For Friction Stir Tack Welding of Aluminum Alloys

The same setup can be used for tack welding and full friction stir welding.

Marshall Space Flight Center,  
Alabama

A small friction-stir-welding tool has been developed for use in tack welding of aluminum-alloy workpieces. It is necessary to tack-weld the workpieces in order to hold them together during friction stir welding because (1) in operation, a full-size friction-stir-welding tool exerts a large force that tends to separate the workpieces and (2) clamping the workpieces is not sufficient to resist this force.

It is possible to tack the pieces together by gas tungsten arc welding, but the process can be awkward and time-consuming and can cause sufficient damage to necessitate rework. Friction stir tack welding does not entail these disadvantages. In addition, friction stir tack welding can be accomplished by use of the same automated equipment (except for the welding tool) used in subsequent full friction stir welding.

The tool for friction stir tack welding (see figure) resembles the tool for full friction stir welding, but has a narrower shoulder and a shorter pin. The shorter pin generates a smaller workpiece-separating force so that clamping suffices to keep the workpieces together. This tool produces a continuous or intermittent partial-penetration tack weld. The tack weld is subsequently consumed by action of the larger tool used in full friction stir welding tool.

*This work was done by Gerald W. Bjorkman, Johnny W. Dinger, and Zachary Loftus of Lockheed Martin Corp. for Marshall Space Flight Center. Further information is contained in a TSP [see page 1].*  
MFS-31392

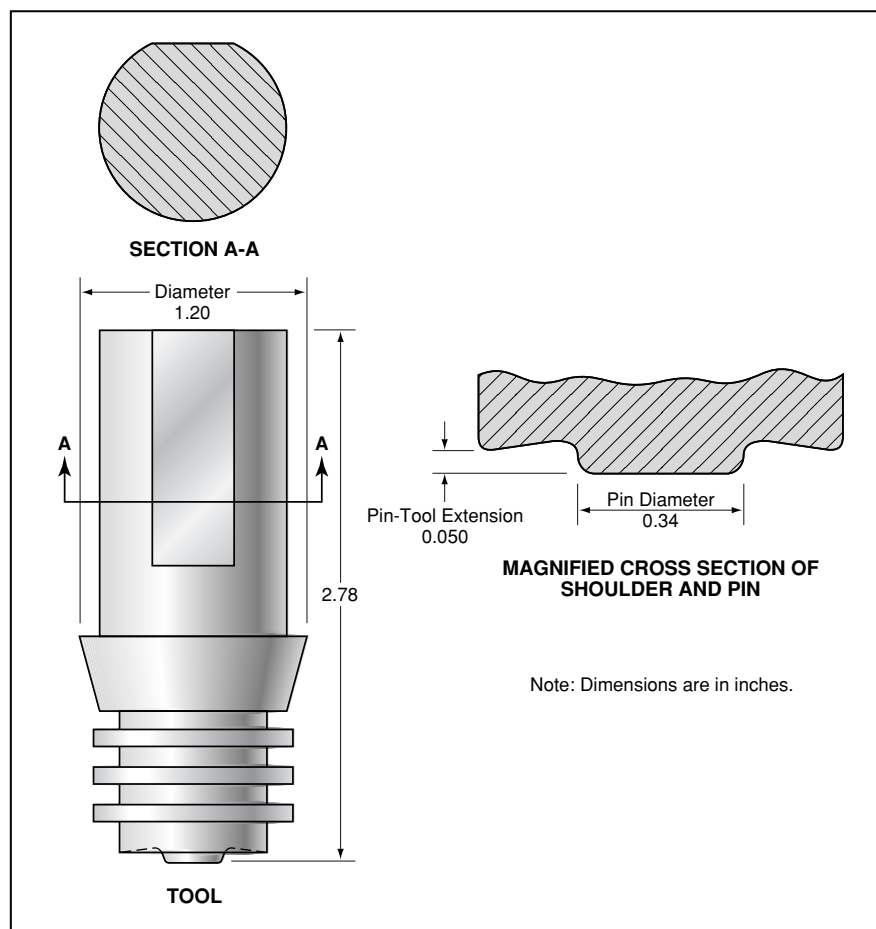

This **Friction-Stir-Welding Tool** is designed specifically for tack welding of 0.32-in. (8.1-mm)-thick pieces of aluminum-lithium alloy 2195. Different values of pin-tool extension and shoulder diameter might be needed for optimum tack welding of different alloys or different thicknesses.

## Improving Plating by Use of Intense Acoustic Beams

This method affords enhanced capabilities for maskless plating and process control.

John H. Glenn Research Center,  
Cleveland, Ohio

An improved method of selective plating of metals and possibly other materials involves the use of directed high-intensity acoustic beams. The beams, typically in the ultrasonic frequency range, can be generated by fixed-focus transducers (see figure) or by phased arrays of transducers excited, variously, by continuous waves, tone bursts, or single pulses. The nonlinear effects produced by these beams are used to alter plating processes in ways that are advantageous.

One of the nonlinear effects is acoustic streaming, which can contribute to selective plating of an object immersed in a plat-

ing solution by providing fresh plating solution to the portion of the object at or near the focus of a beam. The combination of acoustic streaming and acoustic-radiation pressure is effective in removing debris and bubbles, which, if allowed to remain, can contaminate the plating material and/or inhibit the plating process. Acoustic streaming can also be used to reduce concentrations and gradients of concentrations of gases (especially hydrogen) in order to prevent the formation of bubbles. Acoustic streaming can be utilized further to counteract effects of localized electric fields and of gradients of concentration of

the plating solution that can give rise to undesired components of spatial nonuniformity in the plating process.

Another nonlinear effect is heating of the plating solution in the focal region. The local increase in temperature causes a local increase in the rates of chemical reactions and thus in the rate of deposition of plating material.

As an alternative to the immersion form of selective plating, acoustic streaming can be utilized to create a fountain of plating solution, which strikes a selected small area of a part suspended over a pool of plating solution. Plating occurs only on the

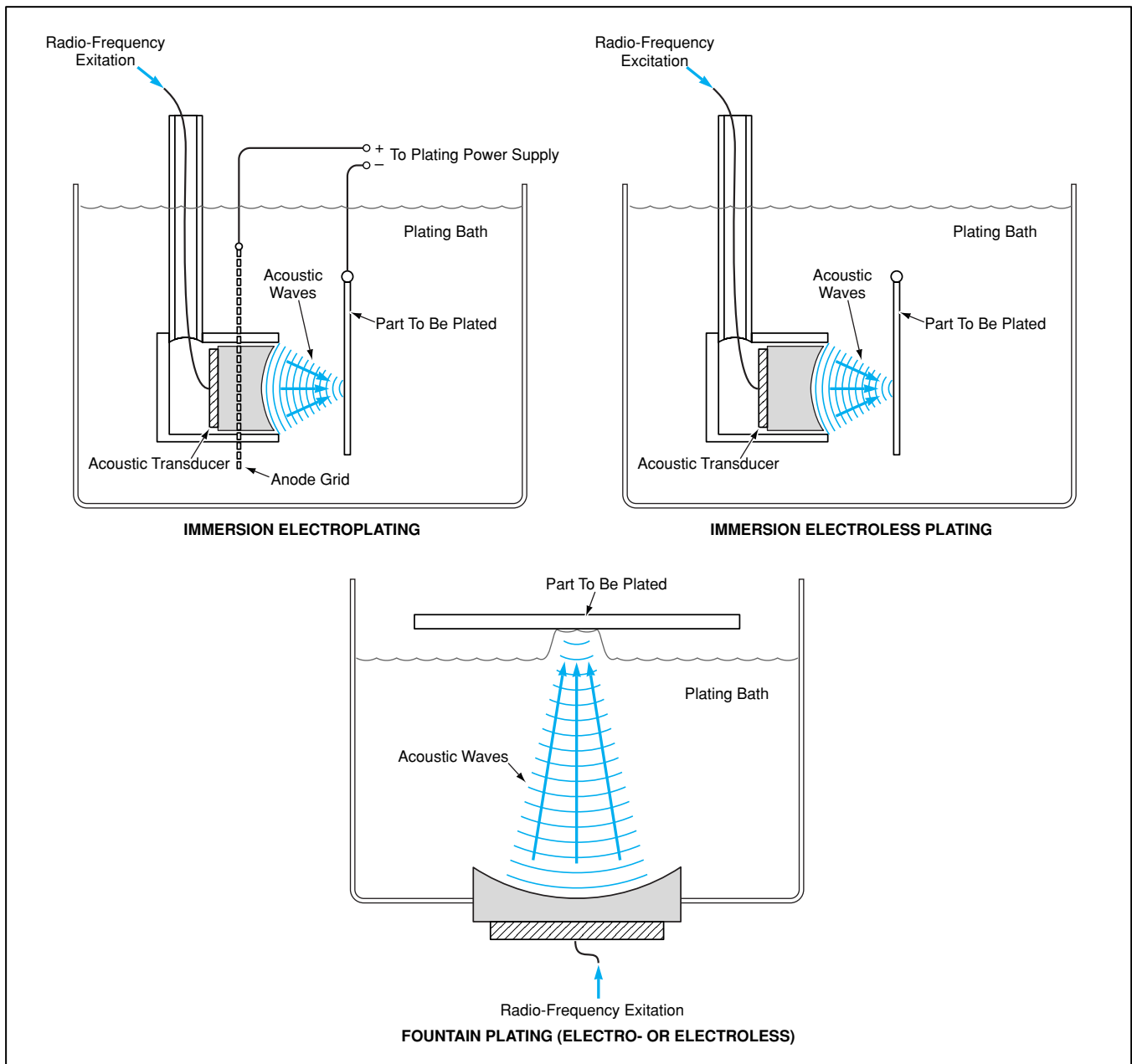

**Focused Acoustic Beams** can be used to enhance electroplating or electroless plating in a variety of different configurations.

area in contact with the plating solution. Whether the immersion or the fountain version of the method is used, the spatial selectivity afforded by the method reduces the need for masking materials, masking processes, and masking devices.

The maskless-plating capability afforded by this method is most applicable to plating applications in which small amounts of excess plating in the areas outside the acoustic-beam focal regions are tolerated or in which plating processes can be reversed to remove this excess plating. An example of such an application

is that of a circuit board coated over its entire surface with a thin layer of gold to increase its resistance to corrosion and enhance its solderability. Typically, there is a need for thicker gold plating in specific locations on such a circuit board — especially at connector contact areas or push-button contact points, where there is a need to maintain reliable electrical contacts in the presence of physical wear. The present method makes it possible to plate metal onto the board with spatially varying thickness in a single operation, without masking.

*This work was done by Richard C. Oeftering of **Glenn Research Center** and Charles Denofrio of Alchemitron Corp. Further information is contained in a TSP [see page 1].*

*Inquiries concerning rights for the commercial use of this invention should be addressed to NASA Glenn Research Center, Commercial Technology Office, Attn: Steve Fedor, Mail Stop 4-8, 21000 Brookpark Road, Cleveland, Ohio 44135. Refer to LEW-17041.*