

Microscale Thermal-Transpiration Gas Pump

This is a prototype of miniature vacuum pumps with no moving parts.

NASA's Jet Propulsion Laboratory,
Pasadena, California

A recent addition to the growing class of microelectromechanical systems (MEMS) is a single stage of a Knudsen compressor. This device was fabricated and tested to demonstrate the feasibility of Knudsen compressors as miniature vacuum pumps for future portable scientific instruments. The attributes of Knudsen compressors that make them attractive as miniature vacuum pumps are that they contain no moving parts and operate without need for lubricants or working fluids.

A Knudsen compressor exploits thermal transpiration of a rarefied gas. The principle of thermal transpiration can be described in terms of an example of two volumes of gas at different temperatures T_1 and T_2 connected by a tube with a radius smaller than the mean free path (λ) of gas molecules. The behavior of this system depends on the Knudsen number ($Kn \equiv \lambda/L$, where L is a characteristic linear dimension of the tube): For Kn less than about $0.01 \lambda/L$, the gas flows as a continuum; for Kn between about 0.01 and 10 , the flow behavior of the gas is transitional between the continuum and free-molecular regimes; for Kn of about 10 or more, the flow regime is free-molecular. In the free-molecular regime, simple balancing of the equilibrium molecular fluxes leads to the following equation for the equilibrium pressures in the two volumes:

$$p_1/p_2 = (T_1/T_2)^{1/2}.$$

The pressure differential can be exploited for pumping.

The advent of MEMS fabrication techniques and of nanopore materials with low thermal conductivities has made it possible to exploit thermal transpiration as more than a laboratory curiosity. This is because passages in pumping devices can now be made so narrow that transitional or free-molecular flow conditions can be obtained in these devices, even at pressures as high as atmospheric.

A Knudsen compressor is a cascade of multiple, individually heated compressor stages that exploit thermal transpiration. Figure 1 is a simplified schematic diagram of single stage, which includes a capillary and a connector section. By virtue of thermal transpiration, an increase in temperature along the capillaries results in an increase in pressure along the capillaries. The capillary section is followed by the connector section, where the pressure is approximately con-

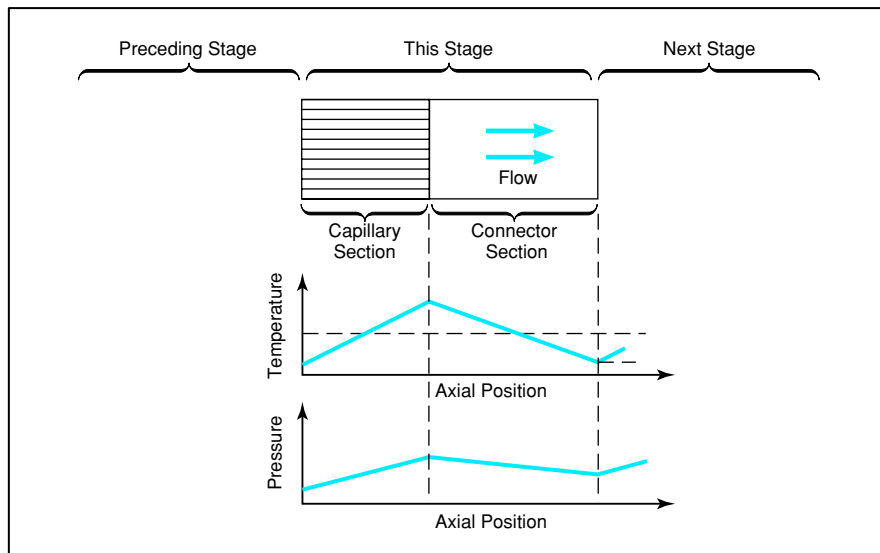

Figure 1. **One Stage of a Knudsen Compressor** exploits thermal transpiration to sustain a small net increase in pressure. Multiple stages like this one are cascaded in order to sustain a usefully large overall increase in pressure.

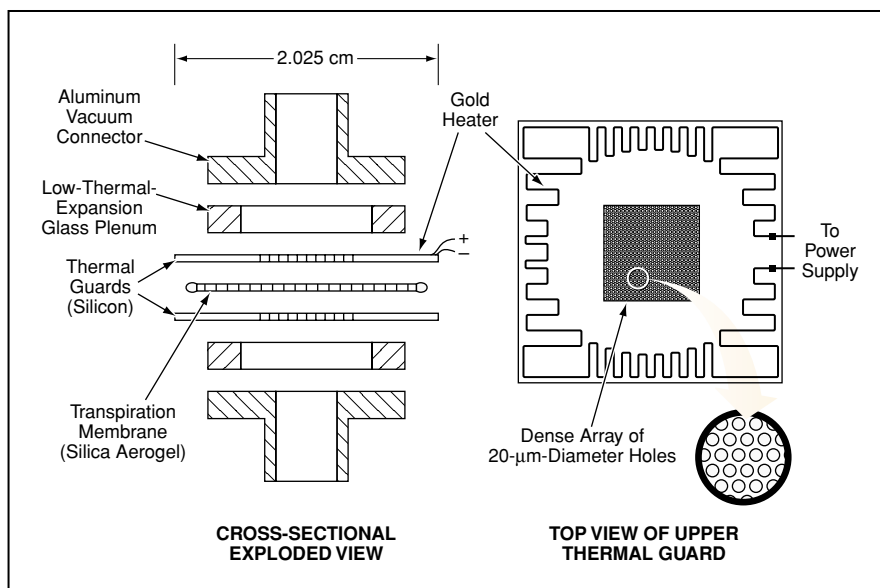

Figure 2. **Advanced Materials and Fabrication Techniques** are essential to the realization of this prototype of a one stage of a microscale Knudsen compressor. The transpiration medium is a $520\text{-}\mu\text{m}$ -thick SiO_2 -aerogel membrane. The hot- and cold-side thermal guards are $400\text{-}\mu\text{m}$ -thick micromachined silicon chips.

start while the temperature falls to its lower value prior to entry to the next stage. The difference in pressure between the hotter and colder sides depends on the Kn values and other parameters; in general, it increases with the transition from the continuum to the free-molecular regime.

The prototype microscale single Knudsen compressor stage (see Figure 2) includes two silicon chips that serve as hot-side and

cold-side thermal guards (the hot-side thermal guard corresponding approximately to the connector section described above), an SiO_2 -aerogel membrane (corresponding approximately to the capillary section described above), two low-thermal-expansion glass plenums, and aluminum vacuum connectors. The role of the thermal guards is to adjust the temperatures of molecules to the desired different values on the opposite

sides of the aerogel transpiration membrane: Each silicon chip contains a dense array of 20- μm -diameter through holes, made by deep reactive-ion etching, that serve as tubes for heating or cooling the gas in them. Thin gold film heaters are patterned on both silicon chips; hence, either silicon

chip can be the hot-side thermal guard. The aerogel has an average pore size of 20 nm and a very low thermal conductivity (17 W/K at atmospheric pressure), and thus satisfies the essential requirements for thermal transpiration to occur when a voltage is applied to one of the heaters.

This work was done by Stephen Vargo, E. Phillip Muntz, and Geoff Shifflett of Caltech for NASA's Jet Propulsion Laboratory. Further information is contained in a TSP [see page 1], NPO-21110

Instrument for Measuring Temperature of Water

An infrared radiometer is able to view water as an almost pure blackbody source.

Stennis Space Center, Mississippi

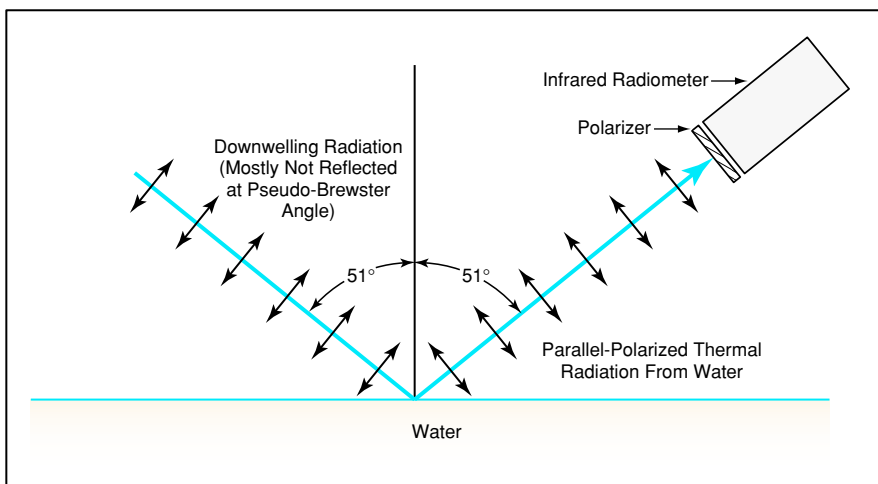

An **Infrared Radiometer** would be aimed toward water at the pseudo-Brewster angle and would respond to radiation polarized parallel (but not perpendicular) to the plane of incidence.

A pseudo-Brewster-angle infrared radiometer has been proposed for use in noncontact measurement of the surface temperature of a large body of water (e.g., a lake or ocean). This radiometer could be situated on a waterborne, airborne, or spaceborne platform.

The design of the pseudo-Brewster-angle radiometer would exploit the spectral-emissivity and polarization characteristics of water to minimize errors attributable to the emissivity of water and to the reflection of downwelling (e.g., Solar and cloud-reflect-ed) infrared radiation. The relevant emissivity and polarization characteristics are the following:

- The Brewster angle is the angle at which light polarized parallel to the plane of incidence on a purely dielectric material is not reflected. The pseudo-Brewster angle, defined for a lossy dielectric (somewhat electrically conductive) material, is the angle for which the reflectivity for parallel-polarized light is minimized. For pure water, the reflectivity for parallel-polarized light is only 2.2×10^{-4} at its pseudo-Brewster angle of 51° . The reflectivity remains near zero, several degrees off from the 51° optimum, allowing this angle of incidence requirement to be easily achieved.
- The wavelength range of interest for

measuring water temperatures is 8 to 12 μm . The emissivity of water for parallel-polarized light at the pseudo-Brewster angle is greater than 0.999 in this wavelength range.

The radiometer would be sensitive in the wavelength range of 8 to 12 μm , would be equipped with a polarizer to discriminate against infrared light polarized perpendicular to the plane of incidence, and would be aimed toward a body of water at the pseudo-Brewster angle (see figure). Because the infrared radiation entering the radiometer would be polarized parallel to the plane of incidence and because very little downwelling parallel-polarized radiation would be reflected into the radiometer on account of the pseudo-Brewster arrangement, the radiation received by the radiometer would consist almost entirely of thermal emission from the surface of the water. Because the emissivity of the water would be very close to 1, the water could be regarded as a close approximation of a blackbody for the purpose of computing its surface temperature from the radiometer measurements by use of the Planck radiation law.

This work was done by Robert Ryan, Thomas Nixon, and Mary Pagnutti of Lockheed Martin Corp. and Vicki Zanoni of Stennis Space Center.

Inquiries concerning rights for the commercial use of this invention should be addressed to the Intellectual Property Manager, Stennis Space Center [see page 1]. Refer to SSC-00134.

Improved Measurement of Coherence in Presence of Instrument Noise

The coherence function can be measured more accurately by accounting for the effects of instrument noise.

John F. Kennedy Space Center, Florida

A method for correcting measured coherence spectra for the effect of incoherent instrument noise has been developed and demonstrated. Coherence measurements are widely used in engineering and science to determine the extent to which two signals are alike. The signals may

come from two different sources or from the same source at different times. The coherence of time-lagged signals from a single source is an excellent indication of the effective lifetime of the signal components as a function of their frequency. Unfortunately, incoherent instrument noise

will bias the measurement to lower values and may lead the user of the data to false conclusions about the longevity of significant features.

The new method may be used whenever both the signal and noise power spectra are known and the noise is incoherent both