



# Technology Focus: Data Acquisition

## Data Relay Board With Protocol for High-Speed, Free-Space Optical Communications

A fade-tolerant data relay system is proposed to ensure reliable delivery of data across an optical channel.

NASA's Jet Propulsion Laboratory, Pasadena, California

In a free-space optical communication system, the mitigation of transient outages through the incorporation of error-control methods is of particular concern, the outages being caused by scintillation fades and obscurants. The focus of this innovative technology is the development of a data relay system for a reliable high-data-rate free-space-based optical-transport network. The data relay boards will establish the link, maintain synchronous connection, group the data into frames, and provide for automatic retransmission (ARQ) of lost or erred frames. A certain Quality of Service (QoS) can then be ensured, compatible with the required data rate. The protocol to be used by the data relay system is based on the draft CCSDS standard data-link protocol "Proximity-1," selected by orbiters to multiple lander assets in the Mars network, for example. In addition to providing data-link protocol capabilities for the free-space optical link and buffering the data, the data relay system will interface directly with user applications over Gigabit Ethernet and/or with high-speed storage resources via Fibre Chan-

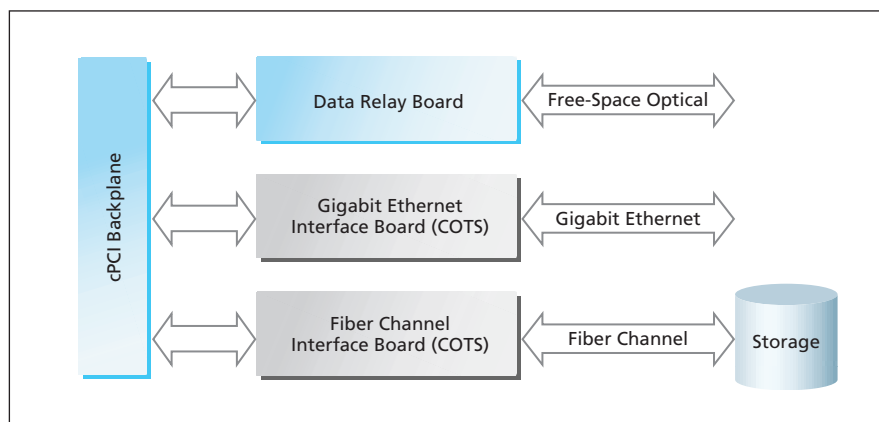

Figure 1. The Data Relay System block diagram shows the interfaces.

nel. The hardware implementation is built on a network-processor-based architecture. This technology combines the power of a hardware switch capable of data switching and packet routing at Gbps rates, with the flexibility of a software-driven processor that can host highly adaptive and reconfigurable protocols used, for example, in wireless local-area networks (LANs).

The system will be implemented in a modular multi-board fashion. The

main hardware elements of the data relay system are the new data relay board developed by Rockwell Scientific, a COTS Gigabit Ethernet board for user interface, and a COTS Fibre Channel board that connects to local storage. The boards reside in a cPCI back plane, and can be housed in a VME-type enclosure.

A block diagram of the data relay system is shown in Figure 1. The data relay board, shown in Figure 2, controls the

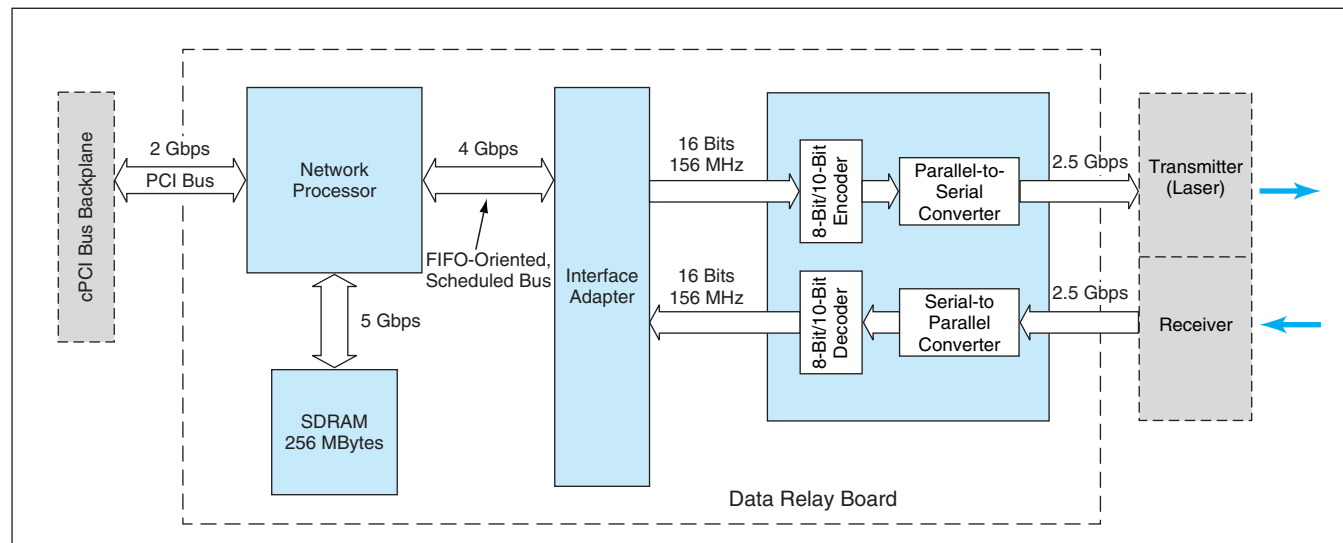

Figure 2. A Data Relay Board would be installed in a free-space optical communication terminal to ensure a reliable high-speed data link. The board would regulate the flow of data between the user application and the optical transceiver.

data flow between the cPCI bus on the one hand and the transmitter and receiver on the other hand once the free-space optical link has been established. The data rates in transmission and reception need not be equal and could even differ by as much as several orders of magnitude. The data relay board would contain a commercially available network processor programmed to perform the primitive data handling function required by the protocol. Using a memory buffer, the network processor would accept, from the user application or storage through the cPCI bus, a stream of data to be transmitted to the laser. The network processor would form the data into appropriately sized frames with headers and frame sequence information to identify frames for the ARQ process. The frames would then be sent to an interface adaptor for frame acquisition and synchronization.

The interface adaptor would then format the data into 16-bit words, add error check bits, and send the data to the serializer and encoder for transmission to the laser.

As successful receipt of frames is acknowledged using the free-space optical link in the reverse direction, the corresponding data are cleared from the local memory so that capacity for new streaming data is made available. In the event of missed or corrupted data frames, the network processor will reconstruct and retransmit the data frames over the free-space optical link.

On the receiving side, the interface adapter will check for errors, while the network processor will check for frames out of sequence. For each received frame, the network processor will generate the appropriate ARQ control frame and pass it to the reverse channel

free-space optical-link interface for transmission.

*This work was done by Malcolm Wright and Loren Clare of Caltech and Gary Gould and Maxim Pedyash of Rockwell Scientific Center for NASA's Jet Propulsion Laboratory. Further information is contained in a TSP (see page 1).*

*In accordance with Public Law 96-517, the contractor has elected to retain title to this invention. Inquiries concerning rights for its commercial use should be addressed to*

*Innovative Technology Assets Management  
JPL*

*Mail Stop 202-233  
4800 Oak Grove Drive  
Pasadena, CA 91109-8099  
(818) 354-2240*

*E-mail: iaoffice@jpl.nasa.gov*

*Refer to NPO-30610, volume and number of this NASA Tech Briefs issue, and the page number.*

## Software and Algorithms for Biomedical Image Data Processing and Visualization

### PlaqTrak automatically assesses plaque deposits on teeth.

NASA's Jet Propulsion Laboratory, Pasadena, California

A new software equipped with novel image processing algorithms and graphical-user-interface (GUI) tools has been designed for automated analysis and processing of large amounts of biomedical image data. The software, called PlaqTrak, has been specifically used for analysis

of plaque on teeth of patients. New algorithms have been developed and implemented to segment teeth of interest from surrounding gum, and a real-time image-based morphing procedure is used to automatically overlay a grid onto each segmented tooth. Pattern recognition

methods are used to classify plaque from surrounding gum and enamel, while ignoring glare effects due to the reflection of camera light and ambient light from enamel regions. The PlaqTrak system integrates these components into a single software suite with an easy-to-use

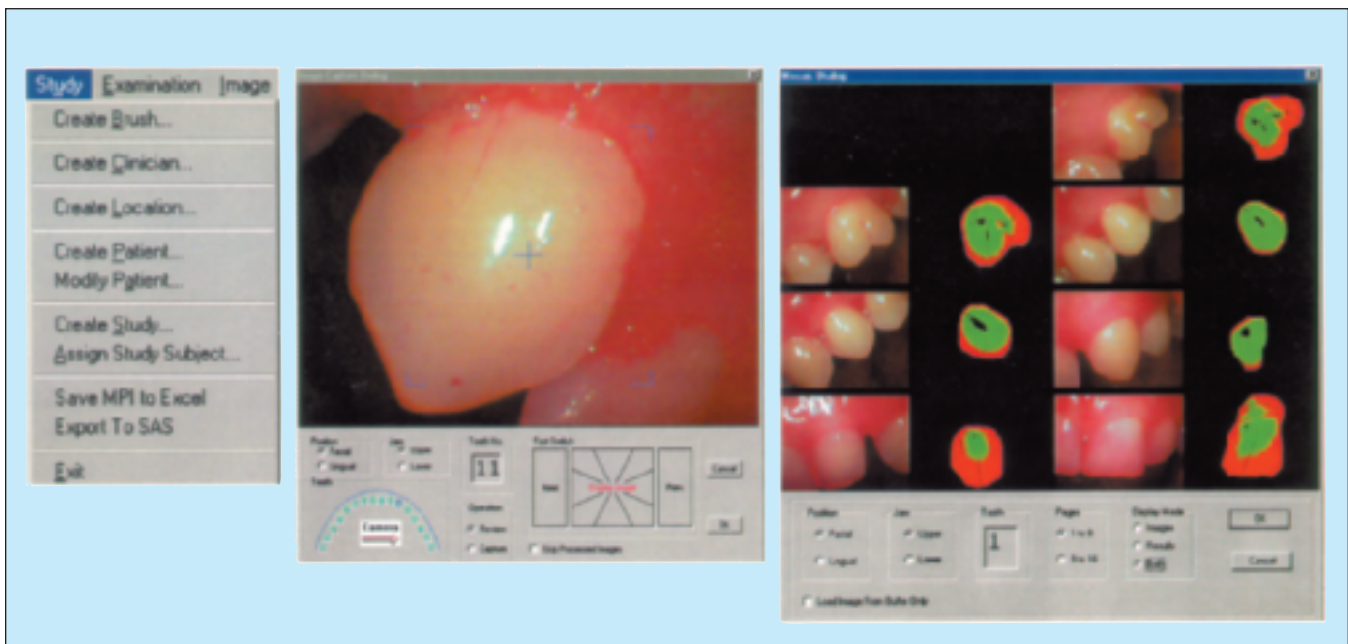

Figure 1. PlaqTrak System Utilities are showing some of the GUI tools.