



Mechanics

Thermally Insulating, Kinematic Tensioned-Fiber Suspension

Tensioned polymer fibers afford both rigidity and high thermal resistance.

Goddard Space Flight Center, Greenbelt, Maryland

Figure 1 shows a salt pill and some parts of a thermally insulating, kinematic suspension system that holds the salt pill rigidly in an adiabatic-demagnetization refrigerator (ADR). “Salt pill” in this context denotes a unit comprising a cylindrical container, a matrix of gold wires in the container, and a cylinder of ferric ammonium alum (a paramagnetic salt) that has been deposited on the wires. The structural members used in this system for both thermal insulation and positioning are

aromatic polyamide fibers (Kevlar® or equivalent) under tension.

This suspension system is designed to satisfy several special requirements to ensure the proper operation of the ADR. These requirements are to (1) maintain the salt pill at a specified position within the cylindrical bore of an electromagnet; (2) prevent vibrations, which would cause dissipation of heat in the salt pill; and (3) minimize the conduction of heat from the electromagnet bore and other neighboring objects to

the salt pill; all while (4) protecting the salt pill (which is fragile) against all tensile and bending loads other than those attributable to its own weight. In addition, the system is required to consist of two subsystems — one for the top end and one for the bottom end of the salt pill — that can be assembled and tensioned separately from each other and from the salt pill, then later attached to the salt pill.

The main reason for choosing aromatic polyamide fibers is that they exhibit a high ratio of stiffness to thermal conductivity in the cryogenic temperature range of the ADR. Their stiffness is about three times that of steel fibers of the same weight. To form each tension member, a bundle of the fibers is formed into a loop by gluing its ends together, the loop is doubled back upon itself several times, and the loop is strung between pulleys, which are then pulled apart by a spring-loading mechanism to place the fibers under tension.

The system is characterized as kinematic because the tension members are positioned and oriented to restrain the salt pill once (and only once) against motion in each of its six degrees of freedom. Figure 2 schematically depicts the overall kinematic configuration, omitting details of the kinematic configurations and spring-loading schemes within the two end suspension subsystems. The top suspension subsystem restrains the top end of the salt pill against translation in any direction (thereby eliminating three degrees of freedom) and against rotation about the cylindrical axis of the salt pill (thereby eliminating another degree of freedom). The bottom suspension subsystem restrains the bottom end of the salt pill against motion in any direction in the plane perpendicular to the cylindrical axis of the salt pill, thereby eliminating the remaining two degrees of freedom.

This work was done by George M. Voellmer of Goddard Space Flight Center. Further information is contained in a TSP (see page 1). GSC-14743-1

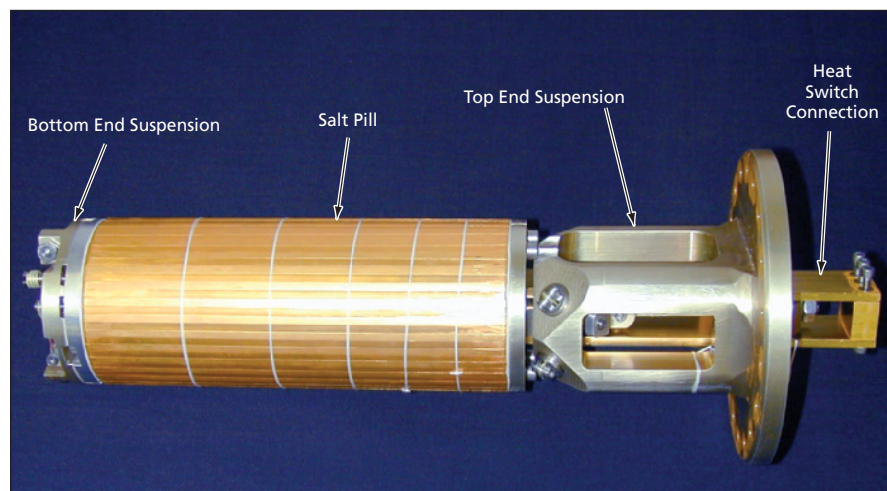

Figure 1. The **Bottom and Top Suspension Subsystems** contain tensioned, thermally insulating polymer fibers in kinematic arrangements. When the components shown here are mounted in the bore of an ADR electromagnet, the salt pill is held rigidly in the specified position.

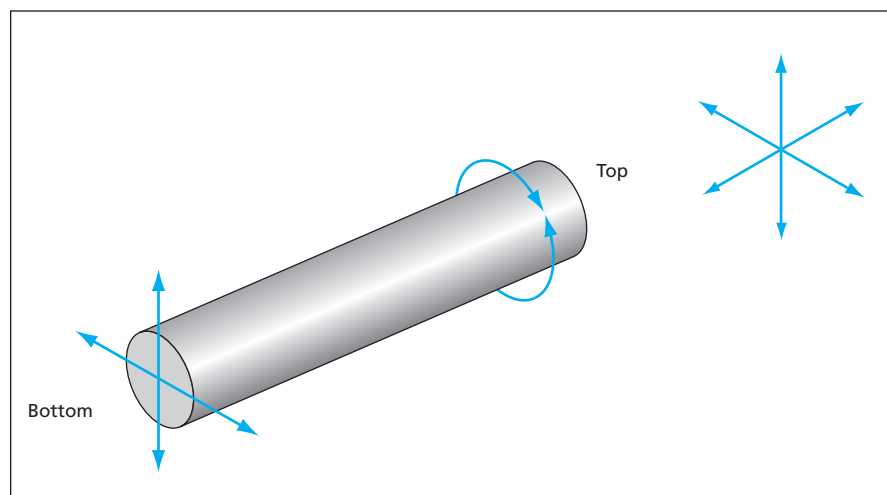

Figure 2. **Motion of the Salt Pill** in the degrees of freedom indicated by the arrows is prevented by the kinematic suspension system.