





TECH BRIEFS

NATIONAL AERONAUTICS AND SPACE ADMINISTRATION

-  **Technology Focus**
-  **Computers/Electronics**
-  **Software**
-  **Materials**
-  **Mechanics**
-  **Machinery/Automation**
-  **Manufacturing**
-  **Bio-Medical**
-  **Physical Sciences**
-  **Information Sciences**
-  **Books and Reports**

INTRODUCTION

Tech Briefs are short announcements of innovations originating from research and development activities of the National Aeronautics and Space Administration. They emphasize information considered likely to be transferable across industrial, regional, or disciplinary lines and are issued to encourage commercial application.

Availability of NASA Tech Briefs and TSPs

Requests for individual Tech Briefs or for Technical Support Packages (TSPs) announced herein should be addressed to

National Technology Transfer Center

Telephone No. (800) 678-6882 or via World Wide Web at www2.nttc.edu/leads/

Please reference the control numbers appearing at the end of each Tech Brief. Information on NASA's Innovative Partnerships Program (IPP), its documents, and services is also available at the same facility or on the World Wide Web at <http://ipp.nasa.gov>.

Innovative Partnerships Offices are located at NASA field centers to provide technology-transfer access to industrial users. Inquiries can be made by contacting NASA field centers and Mission Directorates listed below.

NASA Field Centers and Program Offices

Ames Research Center

Lisa L. Lockyer
(650) 604-1754
lisa.l.lockyer@nasa.gov

Dryden Flight Research Center

Gregory Poteat
(661) 276-3872
greg.poteat@dfrc.nasa.gov

Goddard Space Flight Center

Nona Cheeks
(301) 286-5810
Nona.K.Cheeks.1@nasa.gov

Jet Propulsion Laboratory

Ken Wolfenbarger
(818) 354-3821
james.k.wolfenbarger@jpl.nasa.gov

Johnson Space Center

Helen Lane
(713) 483-7165
helen.w.lane@nasa.gov

Kennedy Space Center

Jim Aliberti
(321) 867-6224
Jim.Aliberti-1@nasa.gov

Langley Research Center

Ray P. Turcotte
(757) 864-8881
r.p.turcotte@larc.nasa.gov

John H. Glenn Research Center at Lewis Field

Robert Lawrence
(216) 433-2921
robert.f.lawrence@nasa.gov

Marshall Space Flight Center

Vernotto McMillan
(256) 544-2615
vernotto.mcmillan@msfc.nasa.gov

Stennis Space Center

John Bailey
(228) 688-1660
john.w.bailey@nasa.gov

NASA Mission Directorates

At NASA Headquarters there are four Mission Directorates under which there are seven major program offices that develop and oversee technology projects of potential interest to industry:

Carl Ray

Small Business Innovation Research Program (SBIR) & Small Business Technology Transfer Program (STTR)
(202) 358-4652
carl.g.ray@nasa.gov

Frank Schowengerdt

Innovative Partnerships Program (Code TD)
(202) 358-2560
fschowen@hq.nasa.gov

John Mankins

Exploration Systems Research and Technology Division
(202) 358-4659
john.c.mankins@nasa.gov

Terry Hertz

Aeronautics and Space Mission Directorate
(202) 358-4636
thertz@mail.hq.nasa.gov

Glen Mucklow

Mission and Systems Management Division (SMD)
(202) 358-2235
gmucklow@mail.hq.nasa.gov

Granville Paules

Mission and Systems Management Division (SMD)
(202) 358-0706
gpaules@mtpe.hq.nasa.gov

Gene Trinh

Human Systems Research and Technology Division (ESMD)
(202) 358-1490
eugene.h.trinh@nasa.gov

John Rush

Space Communications Office (SOMD)
(202) 358-4819
john.j.rush@nasa.gov



TECH BRIEFS

NATIONAL AERONAUTICS AND SPACE ADMINISTRATION



5 Technology Focus: Data Acquisition

- 5 Video Mosaicking for Inspection of Gas Pipelines
- 6 Shuttle-Data-Tape XML Translator
- 6 Highly Reliable, High-Speed, Unidirectional Serial Data Links
- 7 Data-Analysis System for Entry, Descent, and Landing



9 Electronics/Computers

- 9 Hybrid UV Imager Containing Face-Up AlGaIn/GaN Photodiodes
- 10 Multiple Embedded Processors for Fault-Tolerant Computing
- 10 Hybrid Power Management
- 11 Magnetometer Based on Optoelectronic Microwave Oscillator



13 Software

- 13 Program Predicts Time Courses of Human/Computer Interactions
- 13 Chimera Grid Tools
- 13 Astronomer's Proposal Tool
- 13 Conservative Patch Algorithm and Mesh Sequencing for PAB3D
- 14 Fitting Nonlinear Curves by Use of Optimization Techniques
- 14 Tool for Viewing Faults Under Terrain
- 14 Automated Synthesis of Long Communication Delays for Testing
- 14 Solving Nonlinear Euler Equations With Arbitrary Accuracy
- 15 Self-Organizing-Map Program for Analyzing Multivariate Data
- 15 Tool for Sizing Analysis of the Advanced Life Support System
- 15 Control Software for a High-Performance Telerobot
- 15 Java Radar Analysis Tool
- 15 Architecture for Verifiable Software
- 16 Tool for Ranking Research Options
- 16 Enhanced, Partially Redundant Emergency Notification System
- 16 Close-Call Action Log Form
- 16 Task Description Language



17 Materials

- 17 Improved Small-Particle Powders for Plasma Spraying
- 17 Bonding-Compatible Corrosion Inhibitor for Rinsing Metals

- 18 Wipes, Coatings, and Patches for Detecting Hydrazines



19 Machinery/Automation

- 19 Rotating Vessels for Growing Protein Crystals
- 19 Oscillating-Linear-Drive Vacuum Compressor for CO₂
- 20 Mechanically Biased, Hinged Pairs of Piezoelectric Benders



21 Manufacturing

- 21 Apparatus for Precise Indium-Bump Bonding of Microchips



23 Bio-Medical

- 23 Radiation Dosimetry via Automated Fluorescence Microscopy
- 23 Multistage Magnetic Separator of Cells and Proteins
- 24 Elastic-Tether Suits for Artificial Gravity and Exercise
- 24 Multichannel Brain-Signal-Amplifying and Digitizing System



25 Physical Sciences

- 25 Ester-Based Electrolytes for Low-Temperature Li-Ion Cells
- 25 Hygrometer for Detecting Water in Partially Enclosed Volumes
- 26 Radio-Frequency Plasma Cleaning of a Penning Malmberg Trap



29 Books & Reports

- 29 Reduction of Flap Side Edge Noise — the Blowing Flap
- 29 Preventing Accidental Ignition of Upper-Stage Rocket Motors
- 29 Designing Flight Deck Procedures
- 29 Update on High-Temperature Coils for Electromagnets
- 30 SMART Solar Sail
- 30 Further Developments in Microwave Ablation of Prostate Cells
- 30 Imaging Dot Patterns for Measuring Gossamer Space Structures
- 30 Development of Flexible Multilayer Circuits and Cables
- 31 Lightweight Radiator System for a Spacecraft
- 31 Heated-Pressure-Ball Monopropellant Rocket Engine
- 31 Improved Emergency Egress Lighting System for the ISS
- 31 Spacecraft Solar Sails Containing Electrodynamic Tethers
- 32 Advanced Metal Foam Structures for Outer Space

This document was prepared under the sponsorship of the National Aeronautics and Space Administration. Neither the United States Government nor any person acting on behalf of the United States Government assumes any liability resulting from the use of the information contained in this document, or warrants that such use will be free from privately owned rights.



Video Mosaicking for Inspection of Gas Pipelines

This development could lead to automated robotic inspection.

Lyndon B. Johnson Space Center, Houston, Texas

A vision system that includes a specially designed video camera and an image-data-processing computer is under development as a prototype of robotic systems for visual inspection of the interior surfaces of pipes and especially of gas pipelines. The system is capable of providing both forward views and mosaicked radial views that can be displayed in real time or after inspection.

To avoid the complexities associated with moving parts and to provide simultaneous forward and radial views, the video camera is equipped with a wide-angle ($>165^\circ$) "fish-eye" lens aimed along the axis of a pipe to be inspected. Nine white-light-emitting diodes (LEDs) placed just outside the field of view of the lens (see Figure 1) provide ample diffuse illumination for a high-contrast image of the interior pipe wall.

The video camera contains a 2/3-in. (1.7-cm) charge-coupled-device (CCD) photodetector array and functions according to the National Television Standards Committee (NTSC) standard. The video output of the camera is sent to an off-the-shelf video capture board (frame grabber) by use of a peripheral component interconnect (PCI) interface in the computer, which is of the 400-MHz, Pentium II (or equivalent) class.

Prior video-mosaicking techniques are applicable to narrow-field-of-view (low-distortion) images of evenly illuminated, relatively flat surfaces viewed along approximately perpendicular lines by cameras that do not rotate and that move approximately parallel to the viewed surfaces. One such technique for real-time creation of mosaic images of the ocean floor involves the use of visual correspondences based on area correlation, during both the acquisition of separate images of adjacent areas and the consolidation (equivalently, integration) of the separate images into a mosaic image, in order to insure that there are no gaps in the mosaic image.

The data-processing technique used for mosaicking in the present system also involves area correlation, but with several notable differences: Because the wide-angle lens introduces considerable distortion, the image data must be processed to effectively

unwarp the images (see Figure 2). The computer executes special software that includes an unwarping algorithm that takes explicit account of the cylindrical pipe geometry. To reduce the processing time needed for unwarping, parameters of the geometric mapping between the circular view of a fisheye

lens and pipe wall are determined in advance from calibration images and compiled into an electronic lookup table. The software incorporates the assumption that the optical axis of the camera is parallel (rather than perpendicular) to the direction of motion of the camera. The software also com-

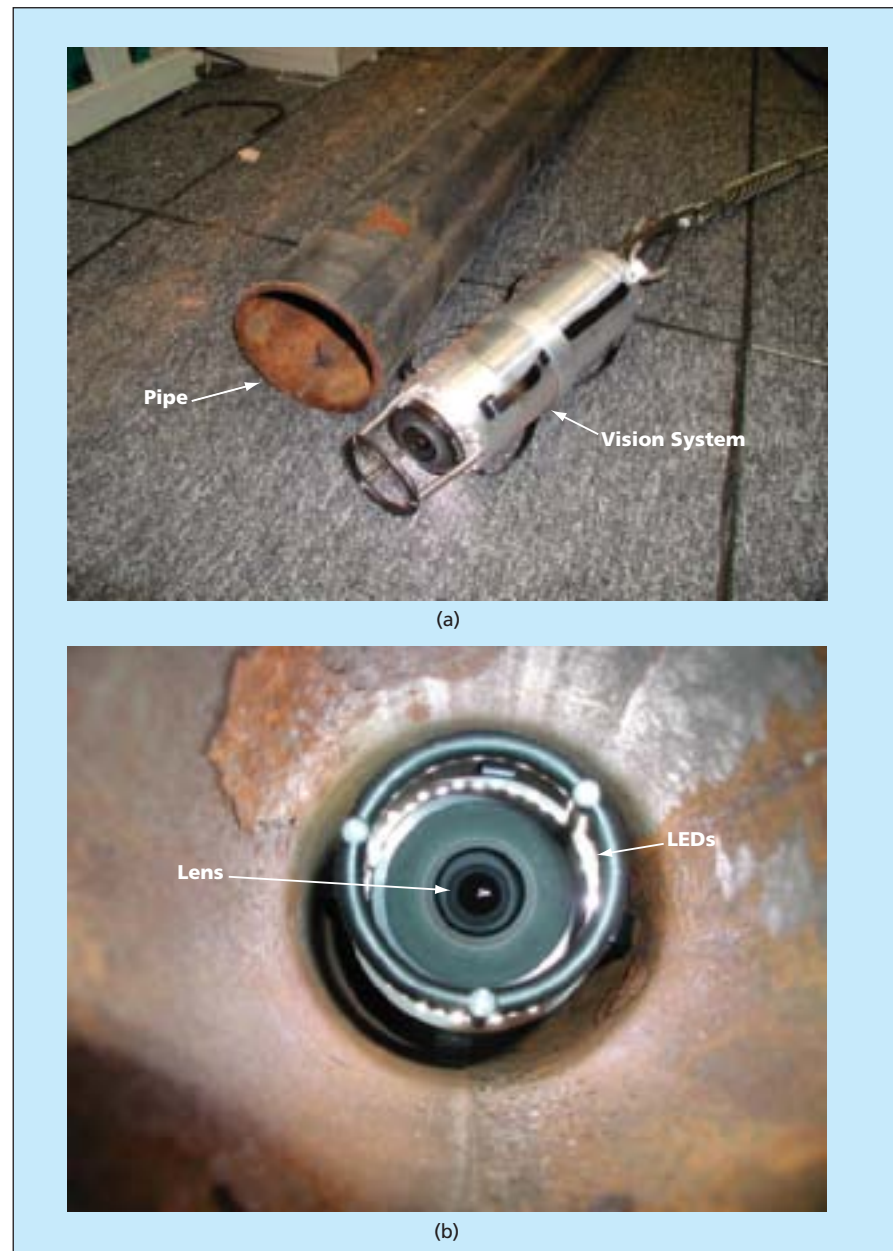

Figure 1. The Camera Is Aimed Along the Axis of a pipe, shown in (a) before insertion into the pipe and in (b) inside the pipe. LEDs provide the illumination needed to acquire video images of the inside pipe wall.

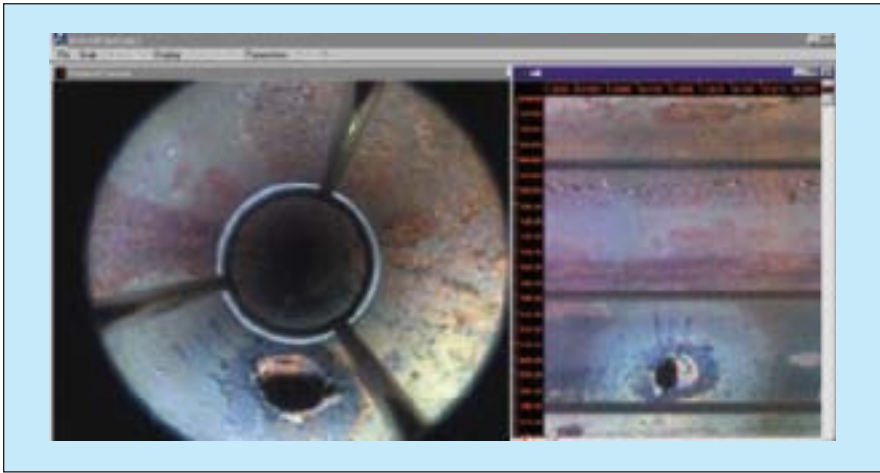

Figure 2. A Picture Taken Looking Along a Pipe is distorted (warped) by the combined effects of the lens and the viewing geometry (left). The image data are processed to unwarped the image (right), yielding an undistorted radial view.

pensates for the decrease in illumination with distance from the ring of LEDs.

The potential advantages to be gained from the development of this system are best understood in comparison

with visual pipeline-inspection systems in current use. Almost all of those systems offer unprocessed video images for viewing by humans in real time or in post-inspection playback. The fatigue induced by

long viewing of mostly featureless images makes such inspection somewhat unreliable, and cost of labor for such inspection is high. If, as planned, the present system could be enhanced by use of additional computer vision techniques, then visual inspection of pipelines could be promoted to supervised inspection, which, in turn, could be a precursor to partly or totally automated inspection. According to one scenario, a system derived from the present one would provide enhanced graphical displays, possibly with highlights on potential defects, and could even provide audible alarms to alert operators. Operators could then concentrate their attention on pipeline sections most likely to contain defects. Reliability of pipeline inspection would thus be increased and the cost of labor reduced.

This work was done by Darby Magruder of Johnson Space Center and Chiun-Hong Chien of Hernandez Engineering. For further information, contact the Johnson Technology Transfer Office at (281) 483-3809. MSC-23075

Shuttle-Data-Tape XML Translator

Lyndon B. Johnson Space Center, Houston, Texas

JSDTImport is a computer program for translating native Shuttle Data Tape (SDT) files from American Standard Code for Information Interchange (ASCII) format into databases in other formats. JS-DTImport solves the problem of organizing the SDT content, affording flexibility to enable users to choose how to store the information in a database to better support client and server applications. JS-DTImport can be dynamically configured by use of a simple Extensible Markup Language (XML) file. JSDTImport uses this

XML file to define how each record and field will be parsed, its layout and definition, and how the resulting database will be structured. JSDTImport also includes a client application programming interface (API) layer that provides abstraction for the data-querying process. The API enables a user to specify the search criteria to apply in gathering all the data relevant to a query. The API can be used to organize the SDT content and translate into a native XML database. The XML format is structured into efficient sections, en-

abling excellent query performance by use of the XPath query language. Optionally, the content can be translated into a Structured Query Language (SQL) database for fast, reliable SQL queries on standard database server computers.

This program was written by Matthew R. Barry and Richard N. Osborne of United Space Alliance for Johnson Space Center. For further information, contact the Johnson Technology Transfer Office at (281) 483-3809. MSC-23579

Highly Reliable, High-Speed, Unidirectional Serial Data Links

Forward error correction would afford reliability in the absence of retransmission.

Lyndon B. Johnson Space Center, Houston, Texas

Highly reliable, high-speed, unidirectional serial data-communication subsystems have been proposed to be installed in an upgrade of the computing systems aboard the space shuttles. The basic design concept of these serial data links is also adaptable to terrestrial use in applications in which there are requirements for highly reliable serial data communications.

The hardware and software aspects of the architecture of the data links are dictated largely by a requirement, in the original space-shuttle application, for one computer to monitor the memory transactions and memory contents of other computers in real time with high reliability and without reliance on requests for retransmission. To minimize

weight while affording a capability to transfer data at a required rate of 2.56×10^8 bits per second, it was decided that the links would be serial ones of the fiber-channel type. ["Fiber channel" denotes a type of serial computer bus that is used to connect a computer (usually a supercomputer) with a high-speed data-storage device. Depending on the spe-

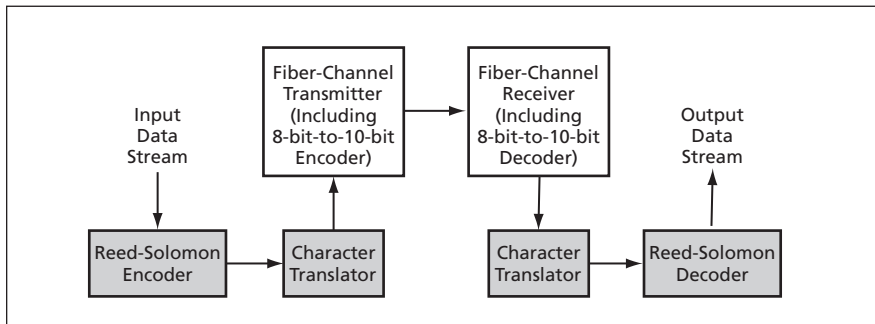

A Unidirectional Serial Data Link according to the proposal would be made from a commercial fiber-channel transmitter and receiver augmented externally with character translators and a Reed-Solomon encoder and decoder.

cific application, the physical connection between the transmitter and receiver could be made via an optical fiber or a twisted pair of wires.]

Heretofore, fiber-channel links have ordinarily been bidirectional and have operated under protocols that provide for receiving stations to detect errors and request retransmission when necessary. In the present case, the time taken by processing to request retransmission

would conflict with the requirement for real-time transfer of data. To ensure reliability without retransmission, a link according to the proposal would utilize a modified version of the normal fiber-channel character set in conjunction with forward error correction by means of a Reed-Solomon code (see figure). The Reed-Solomon encoding and decoding and the translations between the normal and modified character sets

would be effected by logic circuitry external to the fiber-channel transmitter and receiver, which would be commercial off-the-shelf units.

The receiving end of the link could detect and correct errors at a rate as high as 4 million times per second, if necessary. The receiver detects uncorrectable double-byte errors. It has been estimated that uncorrectable-error rate would amount to one failure in about 10^{19} characters.

This work was done by Robert M. Cole and Jamie Bishop of Lockheed Martin Corp. for Johnson Space Center.

Title to this invention has been waived under the provisions of the National Aeronautics and Space Act {42 U.S.C. 2457(f)}, to Lockheed Martin Corp. Inquiries concerning licenses for its commercial development should be addressed to:

*Lockheed Martin Systems Integration
1801 State Route 17C
Building 102
Owego, NY 13827-3998*

Refer to MSC-23763, volume and number of this NASA Tech Briefs issue, and the page number.

Data-Analysis System for Entry, Descent, and Landing

NASA's Jet Propulsion Laboratory, Pasadena, California

A report describes the Entry Descent Landing Data Analysis (EDA), which is a system of signal-processing software and computer hardware for acquiring status data conveyed by multiple-frequency-shift-keying tone signals transmitted by a spacecraft during descent to the surface of a remote planet. The design of the EDA meets the challenge of processing weak, fluctuating signals that are Doppler-shifted by amounts that are only partly predictable. The software supports both real-time and post processing. The software performs fast-Fourier-transform integration, parallel frequency tracking

with prediction, and mapping of detected tones to specific events. The use of backtrack and refinement parallel-processing threads helps to minimize data gaps. The design affords flexibility to enable division of a descent track into segments, within each of which the EDA is configured optimally for processing in the face of signal conditions and uncertainties. A dynamic-lock-state feature enables the detection of signals using minimum required computing power — less when signals are steadily detected, more when signals fluctuate. At present, the hardware comprises eight dual-processor

personal-computer modules and a server. The hardware is modular, making it possible to increase computing power by adding computers.

This work was done by Timothy Pham, Christine Chang, Edgar Sartorius, Susan Finley, Leslie White, Polly Estabrook, and David Fort of Caltech for NASA's Jet Propulsion Laboratory. Further information is contained in a TSP (see page 1).

The software used in this innovation is available for commercial licensing. Please contact Karina Edmonds of the California Institute of Technology at (818) 393-2827. Refer to NPO-41220.



Hybrid UV Imager Containing Face-Up AlGaIn/GaN Photodiodes

An alternative approach offers potential advantages over the flip-chip approach.

NASA's Jet Propulsion Laboratory, Pasadena, California

A proposed hybrid ultraviolet (UV) image sensor would comprise a planar membrane array of face-up AlGaIn/GaN photodiodes integrated with a complementary metal oxide/semiconductor (CMOS) readout-circuit chip. Each pixel in the hybrid image sensor would contain a UV photodiode on the AlGaIn/GaN membrane, metal oxide/semiconductor field-effect transistor (MOSFET) readout circuitry on the CMOS chip underneath the photodiode, and a metal via connection between the photodiode and the readout circuitry (see figure). The proposed sensor design would offer all the advantages of comparable prior CMOS active-pixel sensors and AlGaIn UV detectors while overcoming some of the limitations of prior (AlGaIn/sapphire)/CMOS hybrid image sensors that have been designed and fabricated according to the methodology of flip-chip integration.

AlGaIn is a nearly ideal UV-detector material because its bandgap is wide and adjustable and it offers the potential to attain extremely low dark current. Integration of AlGaIn with CMOS is necessary because at present there are no practical means of realizing readout circuitry in the AlGaIn/GaN material system, whereas the means of realizing readout circuitry in CMOS are well established. In one variant of the flip-chip approach to integration, an AlGaIn chip on a sapphire substrate is inverted (flipped) and then bump-bonded to a CMOS readout circuit chip; this variant results in poor quantum efficiency. In another variant of the flip-chip approach, an AlGaIn chip on a crystalline AlN substrate would be bonded to a CMOS readout circuit chip; this variant is expected to result in narrow spectral response, which would be undesirable in many applications. Two other major disadvantages of flip-chip integration are large pixel size (a consequence of the need to devote sufficient area to each bump bond) and severe restriction on the photodetector structure.

The membrane array of AlGaIn/GaN photodiodes and the CMOS readout circuit for the proposed image sensor would be fabricated separately. The AlGaIn/GaN

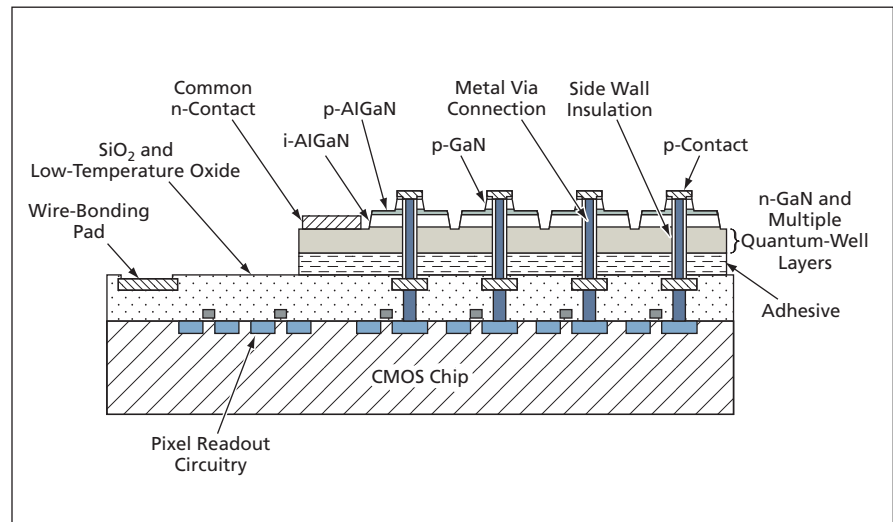

The Proposed Hybrid Image Sensor would comprise a planar membrane array of face-up AlGaIn/GaN photodiodes adhesively bonded to a CMOS readout-circuit chip, with a metal via connection in each pixel.

membrane would be separated from its fabrication substrate by use of laser lift-off or perhaps some other technique that works as well. A temporary holder would be used for lifting off the AlGaIn/GaN membrane, transferring this membrane to the CMOS circuit chip, and keeping the front surface of the membrane facing up in the process. The AlGaIn/GaN membrane would be bonded to the CMOS chip by use of an adhesive, which could be a polyimide or other, similar material. After curing of the adhesive, the portion of the membrane outside the area of the photodiode arrays would be removed by dry etching. Then the metal via connections between the photodiodes and the CMOS readout circuit would be made in all the pixels.

The performance of the proposed image sensor in solar-blind or visible-blind UV imaging would exceed that achievable in flip-chip integration in two ways:

The face-up orientation of the photodiodes would make it possible for UV photons to be detected at the top layer of the photodetector, where the quality of the photodetector material usually exceeds that of the inner layers. As a result, it should be possible to achieve high quantum efficiency, wide and tailorable spec-

tral response, and low dark current.

The metal via connections in the proposed configuration could be made much narrower than the tens-of-microns-wide bonding bumps of a typical flip-chip configuration. The elimination of the need to devote so much pixel area to bump bonds would enable the design and fabrication of much smaller pixels. Hence, it would be possible to achieve greater spatial resolution of the image and to fit more pixels into a given image area.

This work was done by Xinyu Zheng and Bedabrata Pain of Caltech for NASA's Jet Propulsion Laboratory. Further information is contained in a TSP (see page 1).

In accordance with Public Law 96-517, the contractor has elected to retain title to this invention. Inquiries concerning rights for its commercial use should be addressed to:

*Innovative Technology Assets Management
JPL*

*Mail Stop 202-233
4800 Oak Grove Drive
Pasadena, CA 91109-8099
(818) 354-2240*

E-mail: iaoffice@jpl.nasa.gov

Refer to NPO-35079, volume and number of this NASA Tech Briefs issue, and the page number.

Multiple Embedded Processors for Fault-Tolerant Computing

Outputs of processors would be compared to detect and correct bit errors.

NASA's Jet Propulsion Laboratory, Pasadena, California

A fault-tolerant computer architecture has been conceived in an effort to reduce vulnerability to single-event upsets (spurious bit flips caused by impingement of energetic ionizing particles or photons). As in some prior fault-tolerant architectures, the redundancy needed for fault tolerance is obtained by use of multiple processors in one computer. Unlike prior architectures, the multiple processors are embedded in a single field-programmable

gate array (FPGA). What makes this new approach practical is the recent commercial availability of FPGAs that are capable of having multiple embedded processors.

A working prototype (see figure) consists of two embedded IBM PowerPC®405 processor cores and a comparator built on a Xilinx Virtex-II Pro FPGA. This relatively simple instantiation of the architecture implements an error-detection scheme. A planned fu-

ture version, incorporating four processors and two comparators, would correct some errors in addition to detecting them.

This work was done by Gary Bolotin, Robert Watson, Sunant Katanyoutanant, Gary Burke, and Mandy Wang of Caltech for NASA's Jet Propulsion Laboratory. Further information is contained in a TSP (see page 1).
NPO-40575

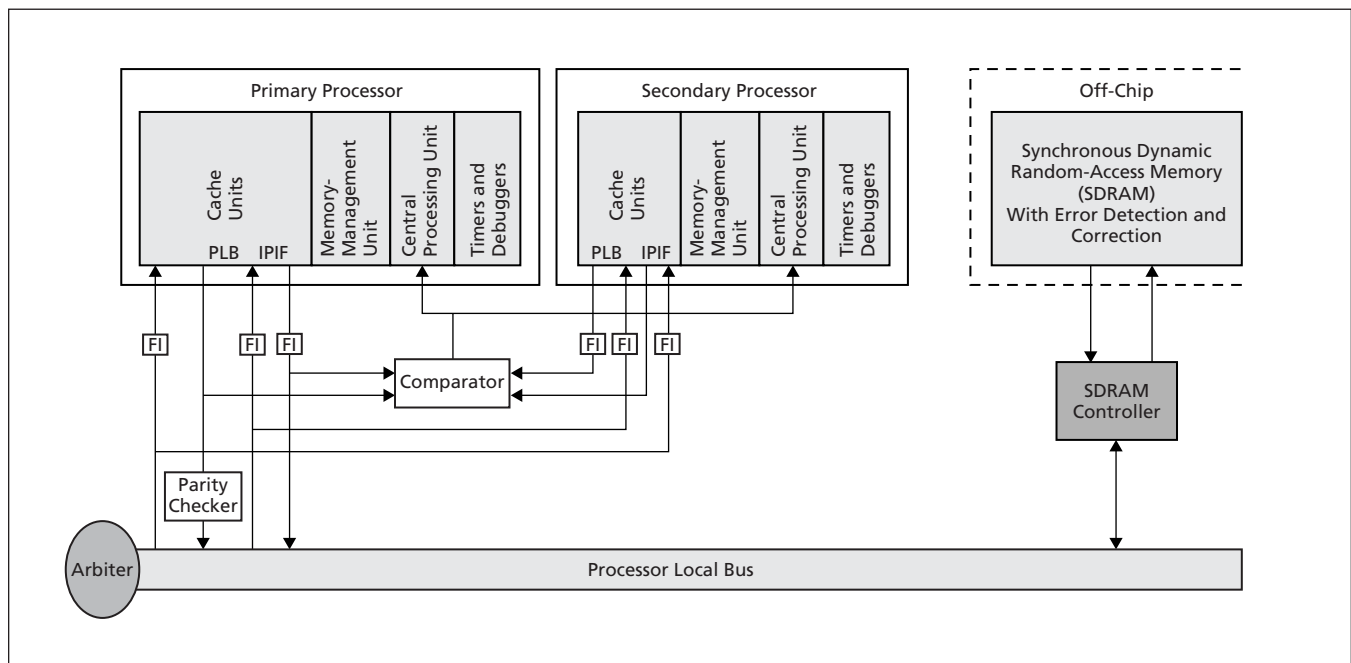

Faults Are Detected in this prototype system by comparison of the outputs of the two processors, which are embedded in a single FPGA. The legend "FI" denotes locations where faults are inserted for testing purpose.

Hybrid Power Management

Ultracapacitors offer numerous advantages over rechargeable batteries.

John H. Glenn Research Center, Cleveland, Ohio

An engineering discipline denoted as hybrid power management (HPM) has emerged from continuing efforts to increase energy efficiency and reliability of hybrid power systems. HPM is oriented toward integration of diverse electric energy-generating, energy-storing, and energy-consuming devices in optimal configurations for both terrestrial and outer-space applications. The basic concepts of HPM are potentially applicable at power levels ranging

from nanowatts to megawatts. Potential applications include terrestrial power-generation, terrestrial transportation, biotechnology, and outer-space power systems.

Instances of this discipline at prior stages of development were reported (though not explicitly labeled as HPM) in three prior NASA Tech Briefs articles: "Ultracapacitors Store Energy in a Hybrid Electric Vehicle" (LEW-16876), Vol. 24, No. 4 (April 2000), page 63; "Photo-

voltic Power Station With Ultracapacitors for Storage" (LEW-17177), Vol. 27, No. 8 (August 2003), page 38; and "Flasher Powered by Photovoltaic Cells and Ultracapacitors" (LEW-17246), Vol. 24, No. 10 (October 2003), page 37. As the titles of the cited articles indicate, the use of ultracapacitors as energy-storage devices lies at the heart of HPM. An ultracapacitor is an electrochemical energy-storage device, but unlike in a conven-

tional rechargeable electrochemical cell or battery, chemical reactions do not take place during operation. Instead, energy is stored electrostatically at an electrode/electrolyte interface. The capacitance per unit volume of an ultracapacitor is much greater than that of a conventional capacitor because its electrodes have much greater surface area per unit volume and the separation between the electrodes is much smaller.

Power-control circuits for ultracapacitors can be simpler than those for batteries, for two reasons: (1) Because of the absence of chemical reactions, charge and discharge currents can be greater than those in batteries, limited only by the electrical resistances of conductors; and (2) whereas the charge level of a battery depends on voltage, temperature, age, and load condition, the charge level of an ultracapacitor, like that of a conventional capacitor, depends only on voltage.

HPM offers many advantages over the conventional power-management approach in which batteries are used to store energy:

- Whereas a typical battery can be charged and discharged about 300 times, an ultracapacitor can be charged

and discharged more than a million times. The longer lifetimes of ultracapacitors contribute to reliability; this is especially significant in such critical applications as medical and spacecraft power systems.

- The longer lifetimes of ultracapacitors greatly reduce life-of-system costs, including the indirect costs of maintenance and downtime.
- The longer lifetimes of ultracapacitors reduce adverse environmental effects, inasmuch as it will probably never be necessary to replace and dispose of ultracapacitors in most applications, whereas batteries must be replaced frequently.
- Disposal problems and the associated contributions to life-of-system costs can be reduced because the chemical constituents of ultracapacitors are less toxic and less environmentally harmful than are those of batteries. Indeed, ultracapacitors are somewhat recyclable.
- Excellent low-temperature performance makes ultracapacitors suitable for storing energy in applications at temperatures too low for batteries.
- The consistent performance of ultraca-

pacitors over time enables reliable operation not possible with batteries.

- Unlike batteries, ultracapacitors can be safely left completely discharged for indefinitely long times.
- Whereas the charge-discharge efficiency in conventional power management using rechargeable batteries is typically about 50 percent, the charge-discharge efficiency in HPM typically exceeds 90 percent.

In an economically important class of applications, HPM can be combined with regenerative braking to increase fuel economy in hybrid electric land vehicles. This concept has been demonstrated in tests of NASA's Hybrid Electric Transit Bus, in which fuel economy was found to increase by 21 percent when regenerative braking with HPM was used.

This work was done by Dennis Eichenberg of Glenn Research Center. Further information is contained in a TSP (see page 1).

Inquiries concerning rights for the commercial use of this invention should be addressed to NASA Glenn Research Center, Innovative Partnerships Office, Attn: Steve Fedor, Mail Stop 4-8, 21000 Brookpark Road, Cleveland, Ohio 44135. Refer to LEW-17520-1.

Magnetometer Based on Optoelectronic Microwave Oscillator

This miniature instrument could also function as an atomic clock.

NASA's Jet Propulsion Laboratory, Pasadena, California

A proposed instrument, intended mainly for use as a magnetometer, would include an optoelectronic oscillator (OEO) stabilized by an atomic cell that could play the role of a magnetically tunable microwave filter. The microwave frequency would vary with the magnetic field in the cell, thereby providing an indication of the magnetic field. The proposed magnetometer would offer a combination of high accuracy and high sensitivity, characterized by flux densities of less than a picotesla. In comparison with prior magnetometers, the proposed magnetometer could, in principle, be constructed as a compact, lightweight instrument: It could fit into a package of about 10 by 10 by 10 cm and would have a mass <0.5 kg.

As described in several prior *NASA Tech Briefs* articles, an OEO is a hybrid of photonic and electronic components that generates highly spectrally pure microwave radiation, and optical radiation modulated by the microwave radiation, through direct conversion between laser light and microwave radiation in an op-

toelectronic feedback loop. As used here, "atomic cell" signifies a cell containing a vapor, the constituent atoms of which can be made to undergo transitions between quantum states, denoted hyperfine levels, when excited by light in a suitable wavelength range. The laser light must be in this range. The energy difference between the hyperfine levels defines the microwave frequency.

In the proposed instrument (see figure), light from a laser would be introduced into an electro-optical modulator (EOM). Amplitude-modulated light from the exit port of the EOM would pass through a fiber-optic splitter having two output branches. The light in one branch would be sent through an atomic cell to a photodiode. The light in the other branch would constitute the microwave-modulated optical output. Part of the light leaving the atomic cell could also be used to stabilize the laser at a frequency in the vicinity of the desired hyperfine or other quantum transition. The microwave signal from

the output of the photodiode would be amplified (if necessary, as explained below) and fed back into the EOM. This system would oscillate if the amplification in the closed loop exceeded the linear absorption of the loop. The microwave amplifier may be unnecessary to sustain stable oscillations, depending on the power of the laser radiation at the photodetector and on particular features of the modulator and optical delay line.

As described in the preceding paragraph, the proposed instrument could function as either an atomic clock or a magnetometer: If the instrument were designed to lock the microwave oscillation to a clock transition (a suitable hyperfine or other quantum transition characterized by a frequency that does not vary measurably with applied fields), then the instrument would function as an atomic clock. If, on the other hand, the instrument were designed to utilize a transition having a frequency that varies with an applied magnetic field, then the

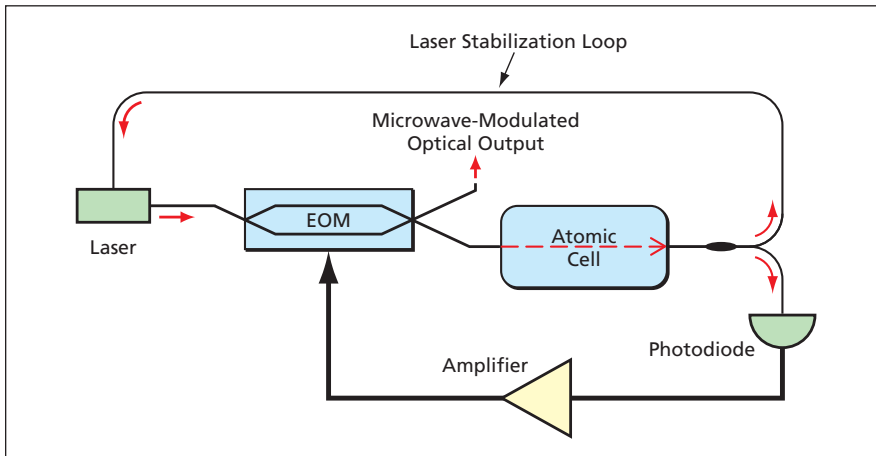

An OEO would be stabilized by use of an atomic cell. This instrument would function as an atomic clock or a magnetometer, depending on whether the oscillation was locked to a clock transition or a magnetically tunable transition, respectively, of the atoms in the cell.

microwave oscillation frequency would serve as an indication of the magnetic flux density along the direction of the light beam. It may be possible to design the instrument to lock the oscillation frequency to either transition, in which

case the same instrument could be used as either an atomic clock or a magnetometer.

The design of the EOM would be a key element of the overall design, affecting the size, power demand, and per-

formance of the proposed instrument. An EOM based on a crystalline whispering-gallery-mode (WGM) resonator could be suitable for this purpose. WGM resonators offer high resonance quality factors ($\geq 10^7$), along with sub-centimeter dimensions that are suitable for tight packaging. The choice of a crystalline WGM resonator would also reduce, relative to other resonators, the amount of power amplification needed in the feedback loop. The OEO could be powered by a semiconductor laser that uses only a few milliwatts of power. Most of the power would be dissipated in the amplifier, which would operate in a low-gain regime and, hence, would not impose a large power demand. It has been estimated the total power demand of the instrument would be less than 1 W.

This work was done by Lute Maleki, Dmitry Strelkov, and Andrey Matsko of Caltech for NASA's Jet Propulsion Laboratory. Further information is contained in a TSP (see page 1). NPO-40958

Program Predicts Time Courses of Human/Computer Interactions

CPM X is a computer program that predicts sequences of, and amounts of time taken by, routine actions performed by a skilled person performing a task. Unlike programs that simulate the interaction of the person with the task environment, CPM X predicts the time course of events as consequences of encoded constraints on human behavior. The constraints determine which cognitive and environmental processes can occur simultaneously and which have sequential dependencies. The input to CPM X comprises (1) a description of a task and strategy in a hierarchical description language and (2) a description of architectural constraints in the form of rules governing interactions of fundamental cognitive, perceptual, and motor operations. The output of CPM X is a Program Evaluation Review Technique (PERT) chart that presents a schedule of predicted cognitive, motor, and perceptual operators interacting with a task environment. The CPM X program allows direct, *a priori* prediction of skilled user performance on complex human-machine systems, providing a way to assess critical interfaces before they are deployed in mission contexts.

This program was written by Alonso Vera of Ames Research Center and Andrew Howes of Cardiff University. Further information is contained in a TSP (see page 1).

Inquiries concerning rights for the commercial use of this invention should be addressed to the Patent Counsel, Ames Research Center, (650) 604-5104. Refer to ARC-15028-1.

Chimera Grid Tools

Chimera Grid Tools (CGT) is a software package for performing computational fluid dynamics (CFD) analysis utilizing the Chimera-overset-grid method. For modeling flows with viscosity about geometrically complex bodies in relative motion, the Chimera-overset-grid method is among the most computationally cost-effective methods for obtaining accurate aerodynamic results. CGT contains a large collection of tools for generating overset grids, preparing inputs for computer programs that solve equations of flow on the grids, and post-processing of flow-solution data. The tools in CGT

include grid editing tools, surface-grid-generation tools, volume-grid-generation tools, utility scripts, configuration scripts, and tools for post-processing (including generation of animated images of flows and calculating forces and moments exerted on affected bodies). One of the tools, denoted OVERGRID, is a graphical user interface (GUI) that serves to visualize the grids and flow solutions and provides central access to many other tools. The GUI facilitates the generation of grids for a new flow-field configuration. Scripts that follow the grid generation process can then be constructed to mostly automate grid generation for similar configurations. CGT is designed for use in conjunction with a computer-aided-design program that provides the geometry description of the bodies, and a flow-solver program.

This program was written by William M. Chan and Stuart E. Rogers of Ames Research Center, Steven M. Nash of ELORET Corp., Pieter G. Buning of Langley Research Center, and Robert L. Meakin of the U.S. Army Aeroflightdynamics Directorate. Further information is contained in a TSP (see page 1).

Inquiries concerning rights for the commercial use of this invention should be addressed to the Technology Partnerships Division, Ames Research Center, (650) 604-2954. Refer to ARC-15399-1.

Astronomer's Proposal Tool

Astronomer's Proposal Tool (APT) is a computer program that assists astronomers in preparing their Phase 1 and Phase 2 Hubble Space Telescope science programs. APT is a successor to the Remote Proposal Submission System 2 (RPS2) program, which has been rendered obsolete by more recent advances in computer software and hardware. APT exploits advances associated with widespread use of the Internet, multiplatform visual development software tools, and overall increases in the power of desktop computer hardware, all in such a way as to make the preparation and submission of proposals more intuitive and make observatory operations less cumbersome. APT provides documentation and help that are friendly, up to date, and easily accessible to users of varying levels of expertise, while defining an extensible framework that is responsive to changes in both technology

and observatory operations. APT consists of two major components: (1) a set of software tools that are intuitive, visual, and responsive and (2) an integrated software environment that unifies all the tools and makes them interoperable. The APT tools include the Visual Target Tuner, Proposal Editor, Exposure Planner, Bright Object Checker, and Visit Planner.

This program was written by a team of software developers led by Tony Krueger at the Space Telescope Science Institute for Goddard Space Flight Center. Further information is contained in a TSP (see page 1).

GSC-14946-1

Conservative Patch Algorithm and Mesh Sequencing for PAB3D

A mesh-sequencing algorithm and a conservative patched-grid-interface algorithm (hereafter "Patch Algorithm") have been incorporated into the PAB3D code, which is a computer program that solves the Navier-Stokes equations for the simulation of subsonic, transonic, or supersonic flows surrounding an aircraft or other complex aerodynamic shapes. These algorithms are efficient, flexible, and have added tremendously to the capabilities of PAB3D. The mesh-sequencing algorithm makes it possible to perform preliminary computations using only a fraction of the grid cells (provided the original cell count is divisible by an integer) along any grid coordinate axis, independently of the other axes. The patch algorithm addresses another critical need in multi-block grid situation where the cell faces of adjacent grid blocks may not coincide, leading to errors in calculating fluxes of conserved physical quantities across interfaces between the blocks. The patch algorithm, based on the Stokes integral formulation of the applicable conservation laws, effectively matches each of the interfacial cells on one side of the block interface to the corresponding fractional cell area pieces on the other side. This approach is comprehensive and unified such that all interface topology is automatically processed without user intervention. This algorithm is implemented in a preprocessing code that creates a cell-by-cell database that will maintain flux conservation at any level of full or reduced grid density as the user may

choose by way of the mesh-sequencing algorithm. These two algorithms have enhanced the numerical accuracy of the code, reduced the time and effort for grid preprocessing, and provided users with the flexibility of performing computations at any desired full or reduced grid resolution to suit their specific computational requirements.

This program was written by S. P. Pao of Langley Research Center and K. S. Abdol-Hamid of Analytical Services and Materials, Inc. Further information is contained in a TSP (see page 1). LAR-17043-1

Fitting Nonlinear Curves by Use of Optimization Techniques

MULTIVAR is a FORTRAN 77 computer program that fits one of the members of a set of six multivariable mathematical models (five of which are nonlinear) to a multivariable set of data. The inputs to MULTIVAR include the data for the independent and dependent variables plus the user's choice of one of the models, one of the three optimization engines, and convergence criteria. By use of the chosen optimization engine, MULTIVAR finds values for the parameters of the chosen model so as to minimize the sum of squares of the residuals. One of the optimization engines implements a routine, developed in 1982, that utilizes the Broydon-Fletcher-Goldfarb-Shanno (BFGS) variable-metric method for unconstrained minimization in conjunction with a one-dimensional search technique that finds the minimum of an unconstrained function by polynomial interpolation and extrapolation without first finding bounds on the solution. The second optimization engine is a faster and more robust commercially available code, denoted Design Optimization Tool, that also uses the BFGS method. The third optimization engine is a robust and relatively fast routine that implements the Levenberg-Marquardt algorithm.

This program was written by Scott A. Hill of Langley Research Center. Further information is contained in a TSP (see page 1). LAR-17091-1

Tool for Viewing Faults Under Terrain

Multi Surface Light Table (MSLT) is an interactive software tool that was developed in support of the QuakeSim project, which has created an earthquake-fault database and a set of earthquake-simulation software tools. MSLT

visualizes the three-dimensional geometries of faults embedded below the terrain and animates time-varying simulations of stress and slip. The fault segments, represented as rectangular surfaces at dip angles, are organized into collections, that is, faults. An interface built into MSLT queries and retrieves fault definitions from the QuakeSim fault database. MSLT also reads time-varying output from one of the QuakeSim simulation tools, called "Virtual California." Stress intensity is represented by variations in color. Slips are represented by directional indicators on the fault segments. The magnitudes of the slips are represented by the duration of the directional indicators in time. The interactive controls in MSLT provide a virtual trackball, pan and zoom, translucency adjustment, simulation playback, and simulation movie capture. In addition, geographical information on the fault segments and faults is displayed on text windows. Because of the extensive viewing controls, faults can be seen in relation to one another, and to the terrain. These relations can be realized in simulations. Correlated slips in parallel faults are visible in the playback of Virtual California simulations.

This software was written by Herbert L Siegel and P. Peggy Li of Caltech for NASA's Jet Propulsion Laboratory. Further information is contained in a TSP (see page 1).

This software is available for commercial licensing. Please contact Karina Edmonds of the California Institute of Technology at (818) 393-2827. Refer to NPO-40781.

Automated Synthesis of Long Communication Delays for Testing

Planetary-Ohio Network Emulator (p-ONE) is a computer program for local laboratory testing of high bandwidth data-communication systems subject to long delays in propagation over interplanetary distances. p-ONE is installed on a personal computer connected to two bidirectional Ethernet interfaces, denoted A and B, that represent local-area networks at opposite ends of a long propagation path. Traffic that is to be passed between A and B is encapsulated in IP (Internet Protocol) packets (e.g., User Data Protocol, UDP). Intercepting this traffic between A and B in both directions, p-ONE time-tags each packet and stores it in memory or on the hard disk of the computer for a user-specified interval that equals the propagation delay to be synthesized. At the expiration of its storage time, each such packet

is sent to its destination (that is, if it was received from A, it is sent to B, or vice versa). The accuracy of the p-ONE software is very high, with zero packet loss through the system and negligible latency. Optionally, p-ONE can be configured to delay all network traffic to and from all network addresses on each Ethernet interface or to selectively delay traffic between specific addresses or traffic of specific types. p-ONE works well with Linux and is also designed to be compatible with other operating systems.

This program was written by Marc Seibert of Glenn Research Center and James McKim of RS Information Systems. Further information is contained in a TSP (see page 1).

Inquiries concerning rights for the commercial use of this invention should be addressed to NASA Glenn Research Center, Innovative Partnerships Office, Attn: Steve Fedor, Mail Stop 4-8, 21000 Brookpark Road, Cleveland, Ohio 44135. Refer to LEW-17440-1.

Solving Nonlinear Euler Equations With Arbitrary Accuracy

A computer program that efficiently solves the time-dependent, nonlinear Euler equations in two dimensions to an arbitrarily high order of accuracy has been developed. The program implements a modified form of a prior arbitrary-accuracy simulation algorithm that is a member of the class of algorithms known in the art as modified expansion solution approximation (MESA) schemes. Whereas millions of lines of code were needed to implement the prior MESA algorithm, it is possible to implement the present MESA algorithm by use of one or a few pages of Fortran code, the exact amount depending on the specific application. The ability to solve the Euler equations to arbitrarily high accuracy is especially beneficial in simulations of aeroacoustic effects in settings in which fully nonlinear behavior is expected — for example, at stagnation points of fan blades, where linearizing assumptions break down. At these locations, it is necessary to solve the full nonlinear Euler equations, and inasmuch as the acoustical energy is of the order of 4 to 5 orders of magnitude below that of the mean flow, it is necessary to achieve an overall fractional error of less than 10^{-6} in order to faithfully simulate entropy, vortical, and acoustical waves.

This work was done by Rodger W. Dyson of Glenn Research Center. Further information is contained in a TSP (see page 1).

Inquiries concerning rights for the commercial use of this invention should be addressed to NASA Glenn Research Center, Commercial Technology Office, Attn: Steve Fedor, Mail Stop 4-8, 21000 Brookpark Road, Cleveland, Ohio 44135. Refer to LEW-17465-1.

Self-Organizing-Map Program for Analyzing Multivariate Data

SOM_VIS is a computer program for analysis and display of multidimensional sets of Earth-image data typified by the data acquired by the Multi-angle Imaging Spectro-Radiometer [MISR (a spaceborne instrument)]. In SOM_VIS, an enhanced self-organizing-map (SOM) algorithm is first used to project a multidimensional set of data into a nonuniform three-dimensional lattice structure. The lattice structure is mapped to a color space to obtain a color map for an image. The Voronoi cell-refinement algorithm is used to map the SOM lattice structure to various levels of color resolution. The final result is a false-color image in which similar colors represent similar characteristics across all its data dimensions. SOM_VIS provides a control panel for selection of a subset of suitably pre-processed MISR radiance data, and a control panel for choosing parameters to run SOM training. SOM_VIS also includes a component for displaying the false-color SOM image, a color map for the trained SOM lattice, a plot showing an original input vector in 36 dimensions of a selected pixel from the SOM image, the SOM vector that represents the input vector, and the Euclidean distance between the two vectors.

This program was written by P. Peggy Li, Joseph C. Jacob, Gary L. Block, and Amy J. Braverman of Caltech for NASA's Jet Propulsion Laboratory. Further information is contained in a TSP (see page 1).

This software is available for commercial licensing. Please contact Karina Edmonds of the California Institute of Technology at (818) 393-2827. Refer to NPO-40666.

Tool for Sizing Analysis of the Advanced Life Support System

Advanced Life Support Sizing Analysis Tool (ALSSAT) is a computer model for sizing and analyzing designs of environmental-control and life support systems (ECLSS) for spacecraft and surface habitats involved in the exploration of Mars and Moon. It performs conceptual designs of advanced life support (ALS) sub-

systems that utilize physicochemical and biological processes to recycle air and water, and process wastes in order to reduce the need of resource resupply. By assuming steady-state operations, ALSSAT is a means of investigating combinations of such subsystems' technologies and thereby assisting in determining the most cost-effective technology combination available. In fact, ALSSAT can perform sizing analysis of the ALS subsystems that are operated dynamically or steady in nature. Using the Microsoft Excel® spreadsheet software with Visual Basic programming language, ALSSAT has been developed to perform multiple-case trade studies based on the calculated ECLSS mass, volume, power, and Equivalent System Mass, as well as parametric studies by varying the input parameters. ALSSAT's modular format is specifically designed for the ease of future maintenance and upgrades.

This program was developed by Hue-Hsia (Jannivine) Yeh, Cheryl B. Brown, and Frank J. Jeng of Lockheed Martin Corp. for Johnson Space Center. For further information, contact the Johnson Technology Transfer Office at (281) 483-3809. MSC-23506

Control Software for a High-Performance Telerobot

A computer program for controlling a high-performance, force-reflecting telerobot has been developed. The goal in designing a telerobot-control system is to make the velocity of the slave match the master velocity, and the environmental force on the master match the force on the slave. Instability can arise from even small delays in propagation of signals between master and slave units. The present software, based on an impedance-shaping algorithm, ensures stability even in the presence of long delays. It implements a real-time algorithm that processes position and force measurements from the master and slave and represents the master/slave communication link as a transmission line. The algorithm also uses the history of the control force and the slave motion to estimate the impedance of the environment. The estimate of the impedance of the environment is used to shape the controlled slave impedance to match the transmission-line impedance. The estimate of the environmental impedance is used to match the master and transmission-line impedances and to estimate the slave/environment force in order to present that force immediately to the operator via the master unit.

This Robert J. Kline-Schoder and William Finger of Creare, Inc., for Johnson Space Center. For further information, contact the Johnson Technology Transfer Office at (281) 483-3809. MSC-23412

Java Radar Analysis Tool

Java Radar Analysis Tool (JRAT) is a computer program for analyzing two-dimensional (2D) scatter plots derived from radar returns showing pieces of the disintegrating Space Shuttle *Columbia*. JRAT can also be applied to similar plots representing radar returns showing aviation accidents, and to scatter plots in general. The 2D scatter plots include overhead map views and side altitude views. The superposition of points in these views makes searching difficult. JRAT enables three-dimensional (3D) viewing: by use of a mouse and keyboard, the user can rotate to any desired viewing angle. The 3D view can include overlaid trajectories and search footprints to enhance situational awareness in searching for pieces. JRAT also enables playback: time-tagged radar-return data can be displayed in time order and an animated 3D model can be moved through the scene to show the locations of the *Columbia* (or other vehicle) at the times of the corresponding radar events. The combination of overlays and playback enables the user to correlate a radar return with a position of the vehicle to determine whether the return is valid. JRAT can optionally filter single radar returns, enabling the user to selectively hide or highlight a desired radar return.

This program was written by Mariusz P. Zaczek of Johnson Space Center. For further information, contact the Johnson Technology Transfer Office at (281) 483-3809. MSC-23742

Architecture for Verifiable Software

Verifiable MDS Architecture (VMA) is a software architecture that facilitates the construction of highly verifiable flight software for NASA's Mission Data System (MDS), especially for smaller missions subject to cost constraints. More specifically, the purpose served by VMA is to facilitate aggressive verification and validation of flight software while imposing a minimum of constraints on overall functionality. VMA exploits the state-based architecture of the MDS and partitions verification issues

into elements susceptible to independent verification and validation, in such a manner that scaling issues are minimized, so that relatively large software systems can be aggressively verified in a cost-effective manner.

This work was done by William Reinholtz and Daniel Dvorak of Caltech for NASA's Jet Propulsion Laboratory. Further information is contained in a TSP (see page 1).

This software is available for commercial licensing. Please contact Karina Edmonds of the California Institute of Technology at (818) 393-2827. Refer to NPO-40842.

Tool for Ranking Research Options

Tool for Research Enhancement Decision Support (TREDS) is a computer program developed to assist managers in ranking options for research aboard the International Space Station (ISS). It could likely also be adapted to perform similar decision-support functions in industrial and academic settings. TREDS provides a ranking of the options, based on a quantifiable assessment of all the relevant programmatic decision factors of benefit, cost, and risk. The computation of the benefit for each option is based on a figure of merit (FOM) for ISS research capacity that incorporates both quantitative and qualitative inputs. Qualitative inputs are gathered and partly quantified by use of the time-tested analytical hierarchical process and used to set weighting factors in the FOM corresponding to priorities determined by the cognizant decision maker(s). Then by use of algorithms developed specifically for this application, TREDS adjusts the projected benefit for each option on the basis of levels of technical implementation, cost, and schedule risk. Based partly on Excel spreadsheets, TREDS provides screens for entering cost, benefit, and risk information. Drop-down boxes are provided for entry of qualitative information. TREDS produces graphical output in multiple formats that can be tailored by users.

This program was written by James N. Ortiz of Johnson Space Center, Kelly Scott of Booz Allen Hamilton Inc., and Harold Smith of Raytheon Co. For further information, contact the Johnson Technology Transfer Office at (281) 483-3809. MSC-23744

Enhanced, Partially Redundant Emergency Notification System

The Johnson Space Center Emergency Notification System (JENS) software utilizes pre-existing computation and communication infrastructure to augment a prior variable-tone, siren-based, outdoor alarm system, in order to enhance the ability to give notice of emergencies to employees working in multiple buildings. The JENS software includes a component that implements an administrative Web site. Administrators can grant and deny access to the administrative site and to an originator Web site that enables authorized individuals to quickly compose and issue alarms. The originator site also facilitates maintenance and review of alarms already issued. A custom client/server application program enables an originator to notify every user who is logged in on a Microsoft Windows-based desktop computer by means of a pop-up message that interrupts, but does not disrupt, the user's work. Alternatively or in addition, the originator can send an alarm message to recipients on an e-mail distribution list and/or can post the notice on an internal Web site. An alarm message can consist of (1) text describing the emergency and suggesting a course of action and (2) a replica of the corresponding audible outdoor alarm.

This program was written by Clark D. Pounds of Science Applications International Corp. for Johnson Space Center. For further information, contact the Johnson Technology Transfer Office at (281) 483-3809. MSC-23773

Close-Call Action Log Form

"Close Call Action Log Form" ("CCALF") is the name of both a computer program and a Web-based service provided by the program for creating an enhanced database of close calls (in the colloquial sense of mishaps that were avoided by small margins) assigned to the Center Operations Directorate (COD) at Johnson Space Center. CCALF provides a single facility for on-line collaborative review of close calls. Through CCALF, managers can delegate responses to employees. CCALF utilizes a pre-existing e-mail system to notify managers that there are close calls to review, but eliminates the need for the prior practices of passing multiple e-mail messages around

the COD, then collecting and consolidating them into final responses: CCALF now collects comments from all responders for incorporation into reports that it generates. Also, whereas it was previously necessary to manually calculate metrics (e.g., numbers of maintenance-work orders necessitated by close calls) for inclusion in the reports, CCALF now computes the metrics, summarizes them, and displays them in graphical form. The reports and all pertinent information used to generate the reports are logged, tracked, and retained by CCALF for historical purposes.

This work was done by Linda M. Spuler and Patricia K. Ford of Johnson Space Center and Darren C. Skeete, Scot Hershman, Pushpa Raviprakash, John W. Arnold, Victor Tran, and Mary Alice Haenze of Science Applications International Corp. For further information, contact the Johnson Technology Transfer Office at (281) 483-3809. MSC-23808

Task Description Language

Task Description Language (TDL) is an extension of the C++ programming language that enables programmers to quickly and easily write complex, concurrent computer programs for controlling real-time autonomous systems, including robots and spacecraft. TDL is based on earlier work (circa 1984 through 1989) on the Task Control Architecture (TCA). TDL provides syntactic support for hierarchical task-level control functions, including task decomposition, synchronization, execution monitoring, and exception handling. A Java-language-based compiler transforms TDL programs into pure C++ code that includes calls to a platform-independent task-control-management (TCM) library. TDL has been used to control and coordinate multiple heterogeneous robots in projects sponsored by NASA and the Defense Advanced Research Projects Agency (DARPA). It has also been used in Brazil to control an autonomous airship and in Canada to control a robotic manipulator.

This program was written by Reid Simmons and David Apfelbaum of Carnegie Mellon University for Johnson Space Center. For further information, contact the Johnson Technology Transfer Office at (281) 483-3809. MSC-23460



Improved Small-Particle Powders for Plasma Spraying

Minimum layer thicknesses needed for complete coverage are reduced.

John H. Glenn Research Center, Cleveland, Ohio

Improved small-particle powders and powder-processing conditions have been developed for use in plasma spray deposition of thermal-barrier and environmental-barrier coatings. Heretofore, plasma-sprayed coatings have typically ranged in thickness from 125 to 1,800 μm . As explained below, the improved powders make it possible to ensure complete coverage of substrates at unprecedentedly small thicknesses — of the order of 25 μm .

Plasma spraying involves feeding a powder into a hot, high-velocity plasma jet. The individual powder particles melt in the plasma jet as they are propelled towards a substrate, upon which they splat to build up a coating. In some cases, multiple coating layers are required. The size range of the powder particles necessarily dictates the minimum thickness of a coating layer

needed to obtain uniform or complete coverage. Heretofore, powder particle sizes have typically ranged from 40 to 70 μm ; as a result, the minimum thickness of a coating layer for complete coverage has been about 75 μm .

In some applications, thinner coatings or thinner coating layers are desirable. In principle, one can reduce the minimum complete-coverage thickness of a layer by using smaller powder particles. However, until now, when powder particle sizes have been reduced, the powders have exhibited a tendency to cake, clogging powder-feeder mechanisms and feed lines.

Hence, the main problem is one of synthesizing smaller-particle powders having desirable flow properties. The problem is solved by use of a process that begins with a spray-drying subprocess to produce

spherical powder particles having diameters of <30 μm . (Spherical-particle powders have the best flow properties.) The powder is then passed several times through a commercial sifter with a mesh to separate particles having diameters <15 μm . The resulting fine, flowable powder is passed through a commercial fluidized-bed powder feeder into a plasma spray jet.

This work was done by QuynhGiao N. Nguyen and Robert A. Miller of Glenn Research Center and George W. Leissler of QSS Group, Inc. Further information is contained in a TSP (see page 1).

Inquiries concerning rights for the commercial use of this invention should be addressed to NASA Glenn Research Center, Commercial Technology Office, Attn: Steve Fedor, Mail Stop 4-8, 21000 Brookpark Road, Cleveland, Ohio 44135. Refer to LEW-17433-1.

Bonding-Compatible Corrosion Inhibitor for Rinsing Metals

Strong adhesive bonds can be made after rinsing with corrosion-inhibiting solutions.

Marshall Space Flight Center, Alabama

A corrosion-inhibiting mixture of compounds has been developed for addition to the water used to rinse metal parts that have been cleaned with aqueous solutions in preparation for adhesive bonding of the metals to rubber and rubberlike materials. Prior to the development of this corrosion inhibitor, the parts (made, variously, of D6AC steel and 7075-T73 aluminum) were rinsed by deionized water, which caused corrosion in some places on the steel parts — especially in such occluded places as sealing surfaces and threaded blind holes.

An integral part of the particular cleaning process is the deposition of a thin layer of silicates and silane primers that increase the strength of the adhesive bond. The corrosion inhibitor is formulated, not only to inhibit corrosion of both D6AC steel and 7075-T73 aluminum, but also to either increase or at least not reduce the strength of the adhesive bond to be formed subsequently. The corrosion inhibitor is a mixture of sodium silicate and sodium tetraborate. The sodium

silicate functions as both a corrosion inhibitor and a bond-strength promoter in association with the silane primers. The sodium tetraborate buffers the rinse solution at the optimum pH and functions as a secondary corrosion inhibitor for the steel.

For a given application, the concentrations of sodium silicate and sodium tetraborate must be chosen in a com-

promise among the needs to inhibit corrosion of steel, inhibit corrosion of aluminum, and minimize cosmetic staining of both steel and aluminum. Concentrations of sodium silicate in excess of 150 parts of silicon per million parts of solution (ppm Si) have been determined to enhance inhibition of corrosion; unfortunately, because of



In a Blind Hole in a D6AC Steel Specimen washed with deionized water, corrosion products can be seen on the thread (a). There is no visible sign of corrosion in a similar specimen rinsed with the corrosion-inhibited solution (b).

the alkalinity of sodium silicate, even a small concentration can raise the pH of the rinse solution to such a level that aluminum becomes corroded despite the inhibiting effect. The pH of a solution that contains a high concentration of sodium silicate can be decreased by adding sodium tetraborate. On the other hand, the addition of sodium tetraborate increases the concentration of dissolved solids to such a high level that cosmetic staining becomes an issue.

One suitable compromise calls for establishing the pH of the rinse solution at 9.5 and including sodium silicate at a concentration of 50 ppm Si. This

choice is justified by the observation that at a pH of 9.5, the rates of corrosion of both steel and aluminum are relatively low, and, therefore, only a minimal concentration of corrosion inhibitor is needed. By reducing the concentration of silicate, one reduces the amount of sodium tetraborate needed to buffer the rinse solution, thereby also reducing the level of cosmetic staining.

The figure depicts the effectiveness of the corrosion inhibitor in blind holes in D6AC steel specimens. In other tests on D6AC steel specimens, rates of corrosion in water containing this corrosion inhibitor were found to be approximately

$10^{-5}\times$ those in deionized water. In similar tests on 7075-T73 aluminum specimens, rates of corrosion in water containing this corrosion inhibitor were found to be only slightly greater than those in deionized water. In still other tests, the strengths of adhesive bonds on steel and aluminum specimens rinsed with corrosion-inhibited solutions were found to be approximately equal to those on specimens rinsed with deionized water.

This work was done by C. R. Saunders, L. A. Wurth, and A. Radar of ATK Thiokol, Inc., for Marshall Space Flight Center. For further information, contact businessdevelopment@atk.com.

MFS-31542

Wipes, Coatings, and Patches for Detecting Hydrazines

With suitable reformulation, other hazardous substances could also be detected.

John F. Kennedy Space Center, Florida

Three color-indicating devices have been conceived as simple, rapid, inexpensive means of detecting hazardous liquid and gaseous substances in settings in which safety is of paramount concern and it would be too time-consuming or otherwise impractical to perform detection by use of such instruments as mass spectrometers. More specifically, these devices are designed for detecting hypergolic fuels (in particular, hydrazines) and hypergolic oxidizers in spacecraft settings, where occasional leakage of these substances in liquid or vapor form occurs and it is imperative to take early corrective action to minimize adverse health effects. With suitable redesign, including reformulation of their color indicator chemicals, these devices could be adapted to detection of other hazardous substances in terrestrial settings (e.g., industrial and military ones).

One of the devices is a pad of a commercially available absorbent material doped with a color indicator. The absorbent material is made from 70 percent polyester and 30 percent nylon and can absorb about eight times its own weight of liquid. The color indicator is a mixture of conventional pH color indicator chemicals. Hydrazine and monomethyl hydrazine, which are basic, cause the color indicator to turn green. In the original intended application, the

pad is wiped on a space suit that is suspected of having been exposed to leaking monomethyl hydrazine during a space walk, before the wearer returns to the interior of the spacecraft. If the wiped surface is contaminated with hydrazine, the pad turns green. In addition, the pad absorbs hydrazine from the wiped surface, thereby reducing or eliminating the hazard. Used pads, including ones that show contamination by hydrazine, can be stored in a sealed plastic bag for subsequent disposal.

The second device, which has been proposed but not yet developed, would comprise a color indicator material in the form of either a coating on a space suit (or other protective garment) or a coating on a sheet that could be easily attached to and detached from the protective garment. The coating material would be a hydrogel doped with a suitable pH indicator. The hydrogel would also serve to maintain a level of moisture needed to support the chemical reaction mentioned in the next sentence. In addition to changing color to indicate the presence of any hypergolic fuel (which is basic) or hypergolic oxidizer (which is acidic) that might splash on the space suit, the pH indicator would also react with the hypergolic fuel or oxidizer and thereby bind it.

The third device is a color dosimeter for detecting hydrazine liquid or vapor



A Porous Cellulose Disk Loaded With KAuCl_4 changes color upon exposure to hydrazine.

coming from microscopic leaks. This device is designed to satisfy several requirements specific to its original intended use in the auxiliary power unit of the space shuttle. These requirements include stability under vacuum, stability at moderate temperature, fast and irreversible change in color upon exposure to hydrazine, and visibility of the color change through polyimide tape. The device is a patch comprising a porous glass-fiber or cellulose patch loaded with potassium tetrachloroaurate (III) [KAuCl_4], which changes color from yellow to purplish gray upon exposure to hydrazine (see figure).

This work was done by Rebecca Young of Kennedy Space Center and William Buttner of Dynacs, Inc. For further information, contact the Kennedy Innovative Partnerships Office at (321) 867-1463. KSC-12400/342/552

Rotating Vessels for Growing Protein Crystals

Rotation would ameliorate adverse effects of gravitation.

Lyndon B. Johnson Space Center, Houston, Texas

Rotating vessels have been proposed as means of growing larger, more nearly uniform protein crystals than would otherwise be possible in the presence of normal Earth gravitation. Heretofore, non-rotating vessels have been used.

It is difficult to grow high-quality protein crystals in the terrestrial gravitational field because of convection plumes created by the interaction between gravitation and density gradients in protein-solution depletion layers around growing crystals. The density gradients and the associated convection plumes cause the surfaces of growing crystals to be exposed to nonuniform solution densities, thereby causing the crystals to form in irregular shapes. The micro-gravitational environment of outer space has been utilized to eliminate gravitation-induced convection, but this approach is generally not favorable because of the high cost and limited availability of space flight.

The use of a rotating vessel according to the proposal is intended to ameliorate the effects of gravitation and the resultant convection, relative to the corresponding effects in a non-rotating vessel. The rotation would exert an averaging effect over time, distributing the convective force on the depletion layer. Therefore, the depletion layer would be more nearly uniform and, as a result, the growing crystal would be more nearly perfect.

The proposal admits of variations (see figure), including the following:

- The growing crystal could be rotated about its own central axis or an external axis.
- The crystal-growth vessel could be of any of various shapes, including cylindrical,

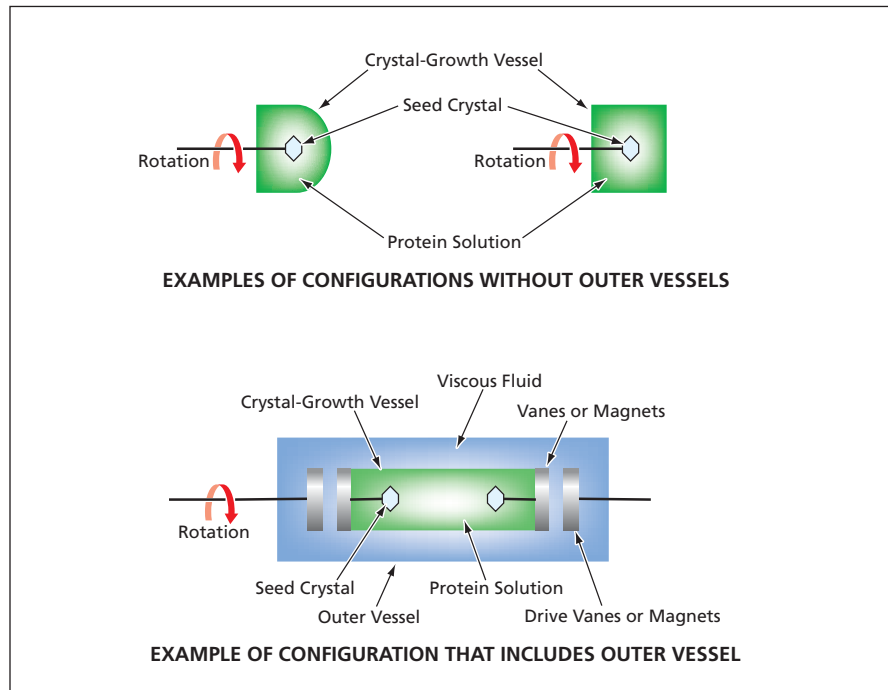

A Hinged Pair of Mechanically Biased Bimorphs constitutes a unit-cell piezoelectric actuator that can generate a positive or negative displacement. Unit cells can be stacked to obtain a greater stroke.

dical, hemispherical, conical, and combinations thereof.

- The crystal-growth vessel could be suspended in a viscous fluid in an outer vessel to isolate the growing crystal from both ambient vibrations and vibrations induced by a mechanism that drives the rotation.
- The rotation could be coupled to the crystal-growth vessel by viscous or magnetic means.
- The crystal-growth vessel could be sup-

ported within the outer vessel by use of a magnetic field.

- The crystal-growth vessel and the outer vessel could be configured in a variety of ways to facilitate heat transfer, instrumentation, and rotation.

This work was done by Paul Cottingham of Wyle Laboratories for Johnson Space Center. For further information, contact the Johnson Technology Transfer Office at (281) 483-3809.

MSC-23212

Oscillating-Linear-Drive Vacuum Compressor for CO₂

Lyndon B. Johnson Space Center, Houston, Texas

A vacuum compressor has been designed to compress CO₂ from ≈1 psia (≈6.9 kPa absolute pressure) to ≈75 psia (≈0.52 MPa), to be insensitive to moisture, to have a long operational life, and to be lightweight, compact, and efficient. The compressor consists mainly of

(1) a compression head that includes hydraulic diaphragms, a gas-compression diaphragm, and check valves; and (2) oscillating linear drive that includes a linear motor and a drive spring, through which compression force is applied to the hydraulic diaphragms. The motor is

driven at the resonance vibrational frequency of the motor/spring/compression-head system, the compression head acting as a damper that takes energy out of the oscillation. The net effect of the oscillation is to cause cyclic expansion and contraction of the gas-compression

diaphragm, and, hence, of the volume bounded by this diaphragm. One-way check valves admit gas into this volume from the low-pressure side during expansion and allow the gas to flow out to the high-pressure side during contrac-

tion. Fatigue data and the results of diaphragm stress calculations have been interpreted as signifying that the compressor can be expected to have an operational life of >30 years with a confidence level of 99.9 percent.

This work was done by Michael G. Izenson and Martin Shimko of Creave, Inc. for Johnson Space Center. For further information, contact the Johnson Technology Transfer Office at (281) 483-3809. MSC-23269

Mechanically Biased, Hinged Pairs of Piezoelectric Benders

Unit cells can be stacked to obtain greater stroke for a given voltage.

Lyndon B. Johnson Space Center, Houston, Texas

The upper part of the figure depicts an actuator that comprises two mechanically biased piezoelectric benders hinged together at their ends and equipped with tabs at their mid-length points for attachment to the relatively moving objects that are to be actuated. In the example of the figure, the attachment tabs are labeled to indicate that the actuator is used to drive a pump piston relative to a base plate. Actuators of this type could be used to drive low-power, small-volume pumps in consumer, medical, and aerospace applications, and to generate and measure linear displacements in such robotic applications as teleoperation and tactile feedback.

Each bender is a bimorph — a unitary plate that comprises an upper and a lower piezoelectric layer plus electrode layers. Benders may also be made of several layers arranged to produce the same effect at the lower operating voltages. As stated above, each bender is mechanically biased; it is fabricated to have a small permanent curvature (the bias curvature) in the absence of applied voltage. As on other bimorphs, the electrical connections on each bender are

arranged so that an applied voltage of suitable polarity causes the upper layer to expand and the lower layer to contract. In this case, the net effect of applying the voltage is that the plate becomes more concave as viewed from below. Conversely, an applied voltage of the opposite polarity causes the plate to become less concave as viewed from below.

The benders in a hinged pair are oriented with their bias curvatures concave inward, so that there is a bias distance between the attachment tabs. The two benders are connected electrically in parallel, with their connection polarities chosen so that an applied voltage of one polarity causes both benders to become more convex inward (more bent), while an applied voltage of the opposite polarity causes both benders to become less convex inward (less bent). An increase or decrease in bend is accompanied by an increase or decrease in distance between the attachment tabs; this increase or decrease is the linear displacement desired for actuation. Because the displacement can be either positive or negative relative to the bias distance, depending on the polarity of the applied voltage, the overall stroke achievable for

a given magnitude of applied voltage is double the stroke achievable in the absence of mechanical bias.

Each hinged pair can be regarded as a unit cell that can serve as a building block for a larger actuator: Multiple unit cells can be stacked (mechanically connected in series), as shown in the lower part of the figure, and electrically connected in parallel to multiply the overall stroke achievable at a given applied voltage.

This work was done by Frank E. Sager of Oceaneering Space Systems for Johnson Space Center.

Title to this invention, covered by U.S. Patent No. 5,889,354, has been waived under the provisions of the National Aeronautics and Space Act {42 U.S.C. 2457 (f)}. Inquiries concerning licenses for its commercial development should be addressed to:

*Oceaneering Space Systems
Attn: Jeffrey D. Brown, Program Development
16665 Space Center Blvd.
Houston, TX 77058-2268
Phone No.: (281) 228-5300*

Refer to MSC-22881, volume and number of this NASA Tech Briefs issue, and the page number.

Apparatus for Precise Indium-Bump Bonding of Microchips

Bonding force is distributed more nearly evenly and controlled more precisely.

NASA's Jet Propulsion Laboratory, Pasadena, California

An improved apparatus has been designed and built for use in precise positioning and pressing of a microchip onto a substrate (which could, optionally, be another microchip) for the purpose of indium-bump bonding. The apparatus (see figure) includes the following:

- A stereomicroscope,
- A stage for precise positioning of the microchip in rotation angle (θ) about the nominally vertical pressing axis and in translation along two nominally horizontal coordinate axes (x and y), and
- An actuator system that causes a bonding tip to press the microchip against the substrate with a precisely controlled force.

In operation, the microscope and the stage are used to position the microchip under the bonding tip and to align the indium bumps on the chip and the substrate, then the actuator system is used to apply a prescribed bonding force for a prescribed time.

The improved apparatus supplants a partly similar prior apparatus that operated with less precision and repeatability, producing inconsistent and unreliable bonds. Results of the use of the prior apparatus included broken microchips, uneven bonds, and bonds characterized, variously, by overcompression or undercompression. In that apparatus, the bonding force was generated and controlled by use of a micrometer head positioned over the center of a spring-loaded scale, and the force was applied to the microchip via the scale, which was equipped for digital readout of the force. The inconsistency of results was attributed to the following causes:

- It was not possible to control the bonding force with sufficient precision or repeatability. Particularly troublesome was the inability to control the force at levels less than the weight of 150 g.
- Excessive compliance in the spring-loaded scale, combined with deviations from parallelarity of the substrate and



This **Microchip-Bonding Apparatus** produces better, more repeatable microchip/substrate indium bump bonds than did a prior apparatus.

bonding-tip surfaces, gave rise to nonuniformity in the pressure applied to the microchip, thereby generating excessive stresses and deformations in the microchip.

In the improved apparatus, the bonding tip and the components that hold the substrate and the microchip are more rigid and precise than in the prior apparatus, so as to ensure less deviation from parallelarity of the bonding-tip and substrate surfaces, thereby ensuring more nearly uniform distribution of bonding force over the area of the microchip. The bonding force is now applied through, and measured by, a load cell that makes it possible to exert finer control over the force. The force can be set at any value between 0 and the weight of 800 g in increments of 0.2 g.

This work was done by Larry Wild, Jerry Mulder, and Nicholas Alvarado of Caltech for NASA's Jet Propulsion Laboratory. Further information is contained in a TSP (see page 1).

In accordance with Public Law 96-517, the contractor has elected to retain title to this invention. Inquiries concerning rights for its commercial use should be addressed to:

*Innovative Technology Assets Management
JPL*

*Mail Stop 202-233
4800 Oak Grove Drive
Pasadena, CA 91109-8099
(818) 354-2240*

E-mail: iaoffice@jpl.nasa.gov

Refer to NPO-35125, volume and number of this NASA Tech Briefs issue, and the page number.



Radiation Dosimetry via Automated Fluorescence Microscopy

With further development, this instrument could enable biodosimetry on a large scale.

Lyndon B. Johnson Space Center, Houston, Texas

A developmental instrument for assessment of radiation-induced damage in human lymphocytes includes an automated fluorescence microscope equipped with a one or more charge-coupled-device (CCD) video camera(s) and circuitry to digitize the video output. The microscope is also equipped with a three-axis translation stage that includes a rotation stage, and a rotary tray that holds as many as thirty specimen slides. The figure depicts one version of the instrument. Once the slides have been prepared and loaded into the tray, the instrument can operate unattended. A computer controls the operation of the stage, tray, and microscope, and processes the digital fluorescence-image data to recognize and count chromosomes that have been broken, presumably by radiation.

The design and method of operation of the instrument exploit fluorescence *in situ* hybridization (FISH) of metaphase chromosome spreads, which is a technique that has been found to be valuable for monitoring the radiation dose to circulating lymphocytes. In the specific FISH protocol used to prepare specimens for this instrument, metaphase lymphocyte cultures are chosen for high mitotic index and highly condensed chromosomes, then several of the largest chromosomes are labeled with three of four differently colored whole-chromosome-staining dyes. The

three dyes, which are used both individually and in various combinations, are fluorescein isothiocyanate (FITC), Texas Red (or equivalent), and Cy5 (or equivalent); The fourth dye — 4',6-diamidino-2-phenylindole (DAPI) — is used as a counterstain.

Under control by the computer, the microscope is automatically focused on the cells and each slide is scanned while the computer analyzes the DAPI-fluorescence images to find the metaphases. Each metaphase field is recentered in the field of view and refocused. Then a four-color image (more precisely, a set of images of the same view in the fluorescent colors of the four dyes) is acquired. By use of pattern-recognition software developed specifically for this instrument, the images in the various colors are processed to recognize the metaphases and count the chromosome fragments of each color within the metaphases. The intermediate results are then further processed to estimate the proportion of cells that have suffered genetic damage.

The prototype instrument scans at an average areal rate of 4.7 mm²/h in unattended operation, finding about 14 metaphases per hour. The false-alarm rate is typically less than 3 percent, and the metaphase-miss rate has been estimated to be less than 5 percent. The counts of chromosomes and fragments thereof are 50 to 70 percent accurate.

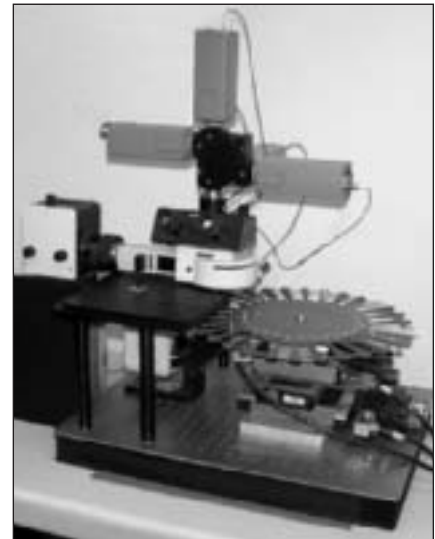

The Original Version of the Automated Fluorescence Microscope included four CCD cameras and dichroic beam splitters for acquiring images in four fluorescence wavelength bands. The instrument was then modified to incorporate a single, more sensitive video camera and a filter wheel for taking a sequential exposures of each microscope field in the fluorescence wavelength bands of interest.

This work was done by Kenneth R. Castleman and Mark Schultze of Perceptive Scientific Instruments, Inc., for Johnson Space Center. For further information, contact the Johnson Technology Transfer Office at (281) 483-3809. MSC-23072

Multistage Magnetic Separator of Cells and Proteins

Purifications and separations can be carried to higher degrees than were previously possible.

Lyndon B. Johnson Space Center, Houston, Texas

The multistage electromagnetic separator for purifying cells and magnetic particles (MAGSEP) is a laboratory apparatus for separating and/or purifying particles (especially biological cells) on the basis of their magnetic susceptibility and magnetophoretic mobility. Whereas a typical prior apparatus based on similar principles offers

only a single stage of separation, the MAGSEP, as its full name indicates, offers multiple stages of separation; this makes it possible to refine a sample population of particles to a higher level of purity or to categorize multiple portions of the sample on the basis of magnetic susceptibility and/or magnetophoretic mobility.

The MAGSEP includes a processing unit and an electronic unit coupled to a personal computer. The processing unit includes upper and lower plates, a plate-rotation system, an electromagnet, an electromagnet-translation system, and a capture-magnet assembly. The plates are bolted together through a roller bearing that allows the plates to rotate with re-

spect to each other. An interface between the plates acts as a seal for separating fluids. A lower cuvette can be aligned with as many as 15 upper cuvette stations for fraction collection during processing.

A two-phase stepping motor drives the rotation system, causing the upper plate to rotate for the collection of each fraction of the sample material. The electromagnet generates a magnetic field across the lower cuvette, while the translation system translates the electromagnet upward along the lower cuvette. The current supplied to the electromagnet, and thus the magnetic flux density at the pole face of the electromagnet, can be set at a programmed value between 0 and 1,400 gauss (0.14 T). The rate of translation

can be programmed between 5 and 2,000 $\mu\text{m/s}$ so as to align all sample particles in the same position in the cuvette.

The capture magnet can be a permanent magnet. It is mounted on an arm connected to a stepping motor. The stepping motor rotates the arm to position the capture magnet above the upper cuvette into which a fraction of the sample is collected.

The electronic unit includes a power switch, power-supply circuitry that accepts 110-Vac input power, an RS-232 interface, and status lights. The personal computer runs the MAGSEP software and controls the operation of the MAGSEP through the RS-232 interface. The status of the power, the translating electromagnet, the capture magnet, and the rotation of the

upper plate are indicated in a graphical user interface on the computer screen.

This work was done by Ken Barton, Mark Ainsworth, Bruce Daily, Scott Dunn, Bill Metz, John Vellinger, Brock Taylor, and Bruce Meador of Space Hardware Optimization Technology, Inc., for Johnson Space Center.

In accordance with Public Law 96-517, the contractor has elected to retain title to this invention. Inquiries concerning rights for its commercial use should be addressed to:

Space Hardware Optimization Technology, Inc.,

5605 Featherengill Road

Floyd Knobs, IN 47119

Phone: (812) 923-9591

Refer to MSC-23124, volume and number of this NASA Tech Briefs issue, and the page number.

Elastic-Tether Suits for Artificial Gravity and Exercise

Lyndon B. Johnson Space Center, Houston, Texas

Body suits harnessed to systems of elastic tethers have been proposed as means of approximating the effects of normal Earth gravitation on crewmembers of spacecraft in flight to help preserve the crewmembers' physical fitness. The suits could also be used on Earth to increase effective gravitational loads for purposes of athletic training. The suit according to the proposal would include numerous small tether-attachment fixtures distributed over its outer surface so as to distribute the artificial gravitational force as nearly evenly as possible over the wearer's body. Elastic tethers would be con-

nected between these fixtures and a single attachment fixture on a main elastic tether that would be anchored to a fixture on or under a floor. This fixture might include multiple pulleys to make the effective length of the main tether great enough that normal motions of the wearer cause no more than acceptably small variations in the total artificial gravitational force. Among the problems in designing the suit would be equalizing the load in the shoulder area and keeping tethers out of the way below the knees to prevent tripping. The solution would likely include running tethers through rings on

the sides. Body suits with a weight or water ballast system are also proposed for very slight spinning space-station scenarios, in which cases the proposed body suits will easily be able to provide the equivalency of a 1-G or even greater load.

This work was done by Paul Torrance of Johnson Space Center, Paul Biesinger of Science Applications International Corp., and Daniel D. Rybicki of Lockheed Martin Corp. For further information, contact the Johnson Technology Transfer Office at (281) 483-3809.

MSC-23145

Multichannel Brain-Signal-Amplifying and Digitizing System

Lyndon B. Johnson Space Center, Houston, Texas

An apparatus has been developed for use in acquiring multichannel electroencephalographic (EEG) data from a human subject. EEG apparatuses with many channels in use heretofore have been too heavy and bulky to be worn, and have been limited in dynamic range to no more than 18 bits. The present apparatus is small and light enough to be

worn by the subject. It is capable of amplifying EEG signals and digitizing them to 22 bits in as many as 150 channels. The apparatus is controlled by software and is plugged into the USB port of a personal computer. This apparatus makes it possible, for the first time, to obtain high-resolution functional EEG images of a thinking brain in a real-life,

ambulatory setting outside a research laboratory or hospital.

This work was done by Alan Gevins of SAM Technology, Inc., for Johnson Space Center. For further information, contact the Johnson Technology Transfer Office at (281) 483-3809.

MSC-23084



Ester-Based Electrolytes for Low-Temperature Li-Ion Cells

NASA's Jet Propulsion Laboratory, Pasadena, California

Electrolytes comprising LiPF_6 dissolved at a concentration of 1.0 M in five different solvent mixtures of alkyl carbonates have been found to afford improved performance in rechargeable lithium-ion electrochemical cells at temperatures as low as -70°C . These and other electrolytes have been investigated in continuing research directed toward extending the lower limit of practical operating temperatures of Li-ion cells. This research at earlier stages, and the underlying physical and chemical principles, were reported in numerous previous NASA Tech Briefs articles, the most re-

cent being "Low-EC-Content Electrolytes for Low-Temperature Li-Ion Cells" (NPO-30226), NASA Tech Briefs, Vol. 27, No. 1 (January 2003), page 46. The ingredients of the present solvent mixtures are ethylene carbonate (EC), ethyl methyl carbonate (EMC), methyl butyrate (MB), methyl propionate (MP), ethyl propionate (EP), ethyl butyrate (EB), and ethyl valerate (EV). In terms of volume proportions of these ingredients, the present solvent mixtures are

- 1EC + 1EMC + 8MB,
- 1EC + 1EMC + 8EB,
- 1EC + 1EMC + 8MP,

- 1EC + 1EMC + 8EV, and
- 1EC + 9EMC.

These electrolytes were placed in Li-ion cells containing carbon anodes and $\text{LiNi}_{0.8}\text{Co}_{0.2}\text{O}_2$ cathodes, and the low-temperature electrical performances of the cells were measured. The cells containing the MB and MP mixtures performed best.

*This work was done by Marshall Smart and Ratnakumar Bugga of Caltech for NASA's Jet Propulsion Laboratory. Further information is contained in a TSP (see page 1).
NPO-41097*

Hygrometer for Detecting Water in Partially Enclosed Volumes

This portable instrument samples humid air from difficult-to-reach spaces.

John F. Kennedy Space Center, Florida

A portable hygrometer has been devised to implement a pre-existing technique for detecting water trapped in partially enclosed volumes that may be difficult to reach and cannot be examined directly. The technique is based on the fact that eventually the air in such a volume becomes saturated or nearly so. The technique is straightforward: One measures the relative humidity and temperature of both the ambient air and a sample of air from the enclosed volume. If the relative humidity of the sample is significantly greater than that of the ambient air and/or if the sample is at or close to the dew point, then it can be concluded that water is trapped in the volume. Of course, the success of this technique depends on the existence of an access hole through which one can withdraw some air from the enclosed volume.

The portable hygrometer (see figure) includes (1) a commercially available small electronic temperature-and-humidity sensor of the "humidity stick" type, (2) a flexible plastic sampling tube with a suction cup at its inlet, and (3) a commercially available sampling pump,

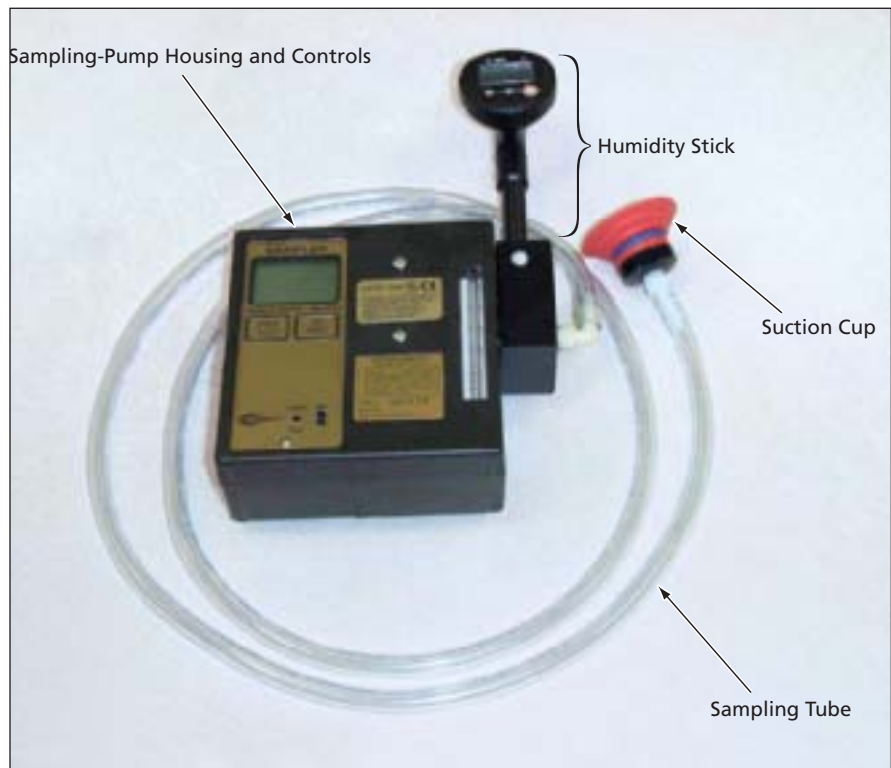

This Portable Hygrometer was assembled from commercially available components and materials.

the air-intake manifold of which is modified for coupling to both the outlet of the sampling tube and the sensory tip of the humidity stick. The total cost of these and ancillary components was about \$1,300 in 2003.

At the beginning of operation, the inlet end of the sampling hose is positioned to collect ambient air and the humidity stick and the sampling pump are turned on. After allowing about 20 seconds for the humidity stick to equilibrate with the sampled ambient air, the temperature and humidity readings of the humidity stick are recorded. Next, the suction cup is placed over the access hole to withdraw air from the enclosed

volume. If water drops are observed in the sampling tube, then there is no need for further sampling, and the sampling pump is stopped immediately to avoid drawing liquid water into the humidity stick and pump. If water drops are not observed in the sampling tube, then the relative-humidity reading is monitored until it reaches a maximum (usually after about 20 seconds), at which time the relative-humidity and temperature readings are recorded.

The suction cup is removed from the access hole and after about 30 seconds for equilibration, the temperature and humidity readings for ambient air are taken again. The suction cup is again

placed over the access hole and the air from the enclosed volume sampled again to obtain second temperature and humidity readings to confirm the first readings. Because some ambient (presumably drier) air could have entered the enclosed volume between the first and second humidity readings, the second enclosed-air humidity reading could be lower than the first one.

This work was done by Robert C. Youngquist of Kennedy Space Center and Jan Surma and Steve Parks of ASRC Aerospace. For further information, contact the Kennedy Innovative Partnerships Office at (321) 867-1463. KSC-12593

Radio-Frequency Plasma Cleaning of a Penning Malmberg Trap

This method is superior to cleaning by baking.

Marshall Space Flight Center, Alabama

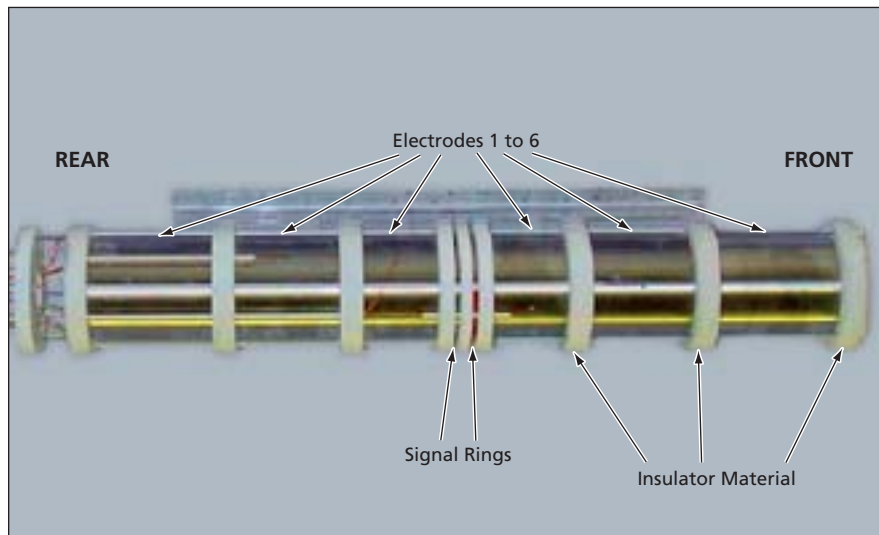

Figure 1. The **Ring Electrodes** used in the operation of a modified Penning-Malmberg trap can also be used in RF generation of plasma for cleaning the trap.

Radio-frequency-generated plasma has been demonstrated to be a promising means of cleaning the interior surfaces of a Penning-Malmberg trap that is used in experiments on the confinement of antimatter. {Such a trap was reported in "Modified Penning-Malmberg Trap for Storing Antiprotons" (MFS-31780), *NASA Tech Briefs*, Vol. 29, No. 3 (March 2005), page 66.} Cleaning of the interior surfaces is necessary to minimize numbers of contaminant atoms and molecules, which reduce confinement times by engaging in matter/antimatter-annihilation reactions with confined antimatter particles.

A modified Penning-Malmberg trap like the one described in the cited prior article includes several collinear ring electrodes (some of which are segmented) inside a tubular vacuum chamber, as illustrated in Figure 1. During operation of the trap, a small cloud of charged antiparticles (e.g., antiprotons or positrons) is confined to a spheroidal central region by means of a magnetic field in combination with DC and radio-frequency (RF) electric fields applied via the electrodes.

In the present developmental method of cleaning by use of RF-generated plasma, one evacuates the vacuum cham-

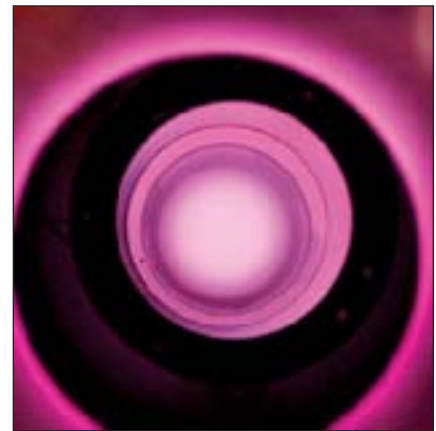

Figure 2. This **View Along the Axis of a Penning-Malmberg Trap** shows a plasma discharge being used for cleaning.

ber, backfills the chamber with hydrogen at a suitable low pressure, and uses an RF-signal generator and baluns to apply RF voltages to the ring electrodes. Each ring is excited in the polarity opposite that of the adjacent ring. The electric field generated by the RF signal creates a discharge in the low-pressure gas. The RF power and gas pressure are adjusted so that the plasma generated in the discharge (see Figure 2) physically and chemically attacks any solid, liquid, and gaseous contaminant layers on the electrode surfaces. The products of the physical and chemical cleaning reactions are gaseous and are removed by the vacuum pumps.

This cleaning method is much more aggressive than is the standard baking of ultrahigh-vacuum systems; adsorbed

gases are removed much faster and more nearly completely.

The cleaning is also superior to that of a system in which plasma is generated outside the apparatus to be cleaned and made to flow through the apparatus. In contemplated further development, the method would be extended to afford a capability for plasma cleaning of, not only the electrodes, but also the interior

wall of the vacuum chamber. For the purpose of cleaning the wall, it would likely be necessary to modify the electrical connections and electrical operating parameters to optimize the array of electrodes as an antenna for generating plasma between the electrodes and the wall.

This work was done by William Herbert Sims III, James Martin, and J. Boise Pearson

of Marshall Space Flight Center and Raymond Lewis of RLewis Co., and Wallace E. Fant of Cortez III. Further information is contained in a TSP (see page 1).

This invention is owned by NASA, and a patent application has been filed. For further information, contact Sammy Nabors, MSFC Commercialization Assistance Lead, at sammy.a.nabors@nasa.gov. Refer to MFS-31825.



Reduction of Flap Side Edge Noise — the Blowing Flap

A technique to reduce the noise radiating from a wing-flap side edge is being developed. As an airplane wing with an extended flap is exposed to a subsonic airflow, air is blown outward through thin rectangular chord-wise slots at various locations along the side edges and side surface of the flap to weaken and push away the vortices that originate in that region of the flap and are responsible for important noise emissions. Air is blown through the slots at up to twice the local flow velocity. The blowing is done using one or multiple slots, where a slot is located along the top, bottom or side surface of the flap along the side edge, or also along the intersection of the bottom (or top) and side surfaces.

This work was done by Florence V. Hutcheson and Thomas F. Brooks of Langley Research Center. Further information is contained in a TSP (see page 1). LAR-16946-1

Preventing Accidental Ignition of Upper-Stage Rocket Motors

A report presents a proposal to reduce the risk of accidental ignition of certain upper-stage rocket motors or other high-energy hazardous systems. At present, mechanically in-line initiators are used for initiation of many rocket motors and/or other high-energy hazardous systems. Electrical shorts and/or mechanical barriers, which are the basic safety devices in such systems, are typically removed as part of final arming or pad preparations while personnel are present. At this time, static discharge, test equipment malfunction, or incorrect arming techniques can cause premature firing. The proposal calls for a modular “out-of-line” ignition system incorporating detonating-cord elements, identified as the donor and the acceptor, separated by an air gap. In the “safe” configuration, the gap would be sealed with two shields, which would prevent an accidental firing of the donor from igniting the system. The shields would be removed to enable normal firing, in which shrapnel generated by the donor would reliably ignite the acceptor to continue the ordnance train. The acceptor would then ignite a through bulkhead initiator (or other similar device), which would ignite the motor or high-energy system. One shield would

be remotely operated and would be moved to the armed position when a launch was imminent or conversely returned to the safe position if the launch were postponed. In the event of failure of the remotely operated shield, the other shield could be inserted manually to “safe” the system.

This work was done by John Hickman, Herbert Morgan, and Michael Cooper of Goddard Space Flight Center and Marcus Murbach of Ames Research Center. Further information is contained in a TSP (see page 1). GSC-14691-1

Designing Flight Deck Procedures

Three reports address the design of flight-deck procedures and various aspects of human interaction with cockpit systems that have direct impact on flight safety. One report, “On the Typography of Flight-Deck Documentation,” discusses basic research about typography and the kind of information needed by designers of flight-deck documentation. Flight crews reading poorly designed documentation may easily overlook a crucial item on the checklist. The report surveys and summarizes the available literature regarding the design and typographical aspects of printed material. It focuses on typographical factors such as proper typefaces, character height, use of lower- and upper-case characters, line length, and spacing. Graphical aspects such as layout, color coding, fonts, and character contrast are discussed; and several cockpit conditions such as lighting levels and glare are addressed, as well as usage factors such as angular alignment, paper quality, and colors. Most of the insights and recommendations discussed in this report are transferable to paperless cockpit systems of the future and computer-based procedure displays (e.g., “electronic flight bag”) in aerospace systems and similar systems that are used in other industries such as medical, nuclear systems, maritime operations, and military systems.

Another report, “Human Factors of Flight-Deck Checklists: The Normal Checklist,” analyzes aircraft checklists (which are regarded as the foundation of pilot standardization and cockpit safety). The improper use, or non-use, of the normal checklist by flight crews is often cited as the probable cause or contributing factor to many aircraft accidents. The report

addresses the functions, format, design, length, usage of cockpit checklists, and the limitations of the humans who must interact with it. The development of the checklist from certification of a new aircraft to its delivery and use by the customer is also discussed in the report. A list of design guidelines for normal checklists is also provided.

Finally, the “On the Design of Flight-Deck Procedures” report examines the general topic of flight-deck procedures, which are the backbone of cockpit operations and a critical aspect of flight safety, and provide a general framework (called the 4 P’s) for developing procedures. The report argues that the procedures are not only hardware/software dependent, as traditionally believed, but are also dependent on the operational environment, the type of people who operate them and the culture of the company they work for, and the nature of the companies’ operations. Four factors are emphasized throughout the document: compatibility, consistency, quality management, and feedback. Although the report is based on airline operations, the issues addressed in the report have already been applied to other complex and high-risk systems, such as nuclear power production, manufacturing process control, space flight, military operations, and high-technology medical practice.

This work was done by Asaf Degani of Ames Research Center and Earl Wiener of the University of Miami. Further information is contained in a TSP (see page 1).

Inquiries concerning rights for the commercial use of this invention should be addressed to the Technology Partnerships Division, Ames Research Center, (650) 604-2954. Refer to ARC-15248-1.

Update on High-Temperature Coils for Electromagnets

A report revisits the subject matter of “High-Temperature Coils for Electromagnets” (LEW-17164), *NASA Tech Briefs*, Vol. 26, No. 8, (August 2002) page 38. To recapitulate: Wires have been developed for use in electromagnets that operate at high temperatures. The starting material for a wire of this type can be either a nickel-clad, ceramic-insulated copper wire or a bare silver wire. The wire is covered by electrical-insulation material that is intended to withstand operating temperatures in the range from 800 to 1,300 °F (≈430 to ≈700 °C): The starting wire is either primarily wrapped with S-glass as

an insulating material or else covered with another insulating material wrapped in S-glass prior to the winding process. A ceramic binding agent is applied as a slurry during the winding process to provide further insulating capability. The turns are pre-bent during winding to prevent damage to the insulation. The coil is then heated to convert the binder into ceramic. The instant report mostly reiterates the prior information and presents some additional information on the application of the ceramic binding agent and the incorporation of high-temperature wire into the windings.

This work was done by Albert F. Kascak and Gerald T. Montague of Glenn Research Center and Alan Palazzolo, Jason Preuss, Bart Carter, Randall Tucker, and Andrew Hunt of Texas A&M University. Further information is contained in a TSP (see page 1).

Inquiries concerning rights for the commercial use of this invention should be addressed to NASA Glenn Research Center, Commercial Technology Office, Attn: Steve Fedor, Mail Stop 4-8, 21000 Brookpark Road, Cleveland, Ohio 44135. Refer to LEW-17467-1.

SMART Solar Sail

A report summarizes the design concept of a super miniaturized autonomous reconfigurable technology (SMART) solar sail — a proposed deployable, fully autonomous solar sail for use in very fine station keeping of a spacecraft. The SMART solar sail would include a reflective film stretched among nodes of a SMART space frame made partly of nanotubule struts. A microelectromechanical system (MEMS) at each vertex of the frame would spool and unspool nanotubule struts between itself and neighboring nodes to vary the shape of the frame. The MEMSs would be linked, either wirelessly or by thin wires within the struts, to an evolvable neural software system (ENSS) that would control the MEMSs to reconfigure the sail as needed. The solar sail would be highly deformable from an initially highly compressed configuration, yet also capable of enabling very fine maneuvering of the spacecraft by means of small sail-surface deformations. The SMART Solar Sail would be connected to the main body of the spacecraft by a SMART multi-tether structure, which would include MEMS actuators like those of the frame plus tethers in the form of longer versions of the struts in the frame.

This work was done by Steven A. Curtis of Goddard Space Flight Center. Further information is contained in a TSP (see page 1). GSC-14762-1

Further Developments in Microwave Ablation of Prostate Cells

A report presents additional information about the subject matter of “Microwave Treatment of Prostate Cancer and Hyperplasia” (MSC-23049), *NASA Tech Briefs*, Vol. 29, No. 6 (June 2005), page 62. To recapitulate: the basic idea is to use microwaves to heat and thereby kill small volumes of unhealthy prostate tissue. The prostate is irradiated with microwaves from one or more antennas positioned near the prostate by means of catheters inserted in the urethra and/or colon. The microwave frequency, power, and exposure time, phasing, positions, and orientations of the antennas may be chosen to obtain the desired temperature rise in the heated region and to ensure that the location and extent of the heated region coincides with the region to be treated to within a few millimeters. Going beyond the description in the cited previous article, the report includes a diagram that illustrates typical placement of urethra and colon antenna catheters and presents results of computationally simulated prostate-heating profiles for several different combinations of antenna arrangements, frequencies, and delivered-energy levels as well as experimental results within phantom materials. The advantage of the two-antenna technology is that the heat generated at each antenna is significantly reduced from that associated with only one antenna. The microwave energy radiated from each antenna is focused at the tumor center by adjusting the phasing of the irradiated microwave signal from the antennas.

This work was done by G. Dickey Arndt and Phong Ngo of Johnson Space Center and Jim R. Carl and George W. Raffoul, independent consultants.

This invention is owned by NASA, and a patent application has been filed. Inquiries concerning nonexclusive or exclusive license for its commercial development should be addressed to the Patent Counsel, Johnson Space Center, (281) 483-0837. Refer to MSC-23427.

Imaging Dot Patterns for Measuring Gossamer Space Structures

A paper describes a photogrammetric method for measuring the changing shape of a gossamer (membrane) structure deployed in outer space. Such a structure is typified by a solar sail comprising a transparent polymeric membrane aluminized on its Sun-facing side

and coated black on the opposite side. Unlike some prior photogrammetric methods, this method does not require an artificial light source or the attachment of retroreflectors to the gossamer structure. In a basic version of the method, the membrane contains a fluorescent dye, and the front and back coats are removed in matching patterns of dots. The dye in the dots absorbs some sunlight and fluoresces at a longer wavelength in all directions, thereby enabling acquisition of high-contrast images from almost any viewing angle. The fluorescent dots are observed by one or more electronic camera(s) on the Sun side, the shade side, or both sides. Filters that pass the fluorescent light and suppress most of the solar spectrum are placed in front of the camera(s) to increase the contrast of the dots against the background. The dot image(s) in the camera(s) are digitized, then processed by use of commercially available photogrammetric software.

This work was done by A. A. Dorrington, P. M. Danehy, T. W. Jones, R. S. Pappa, and J. W. Connell of Langley Research Center. Further information is contained in a TSP (see page 1). LAR-16596-1

Development of Flexible Multilayer Circuits and Cables

A continuing program addresses the development of flexible multilayer electronic circuits and associated flexible cables. This development is undertaken to help satisfy aerospace-system-engineering requirements for efficient, lightweight electrical and electronic subsystems that can fit within confined spaces, adhere to complexly shaped surfaces, and can be embedded within composite materials. Heretofore, substrate layers for commercial flexible circuitry have been made from sheets of Kapton (or equivalent) polyimide and have been bonded to copper conductors and to other substrate layers by means of adhesives. The substrates for the present developmental flexible circuitry are made from thin films of a polyimide known as LaRC™-SI. This polyimide is thermoplastic and, therefore, offers the potential to eliminate delamination and the need for adhesives. The development work undertaken thus far includes experiments in the use of several techniques of design and fabrication (including computer-aided design and fabrication) of representative flexible circuits. Anticipated fu-

ture efforts would focus on multilayer bonding, fabrication of prototypes, and overcoming limitations.

This work was done by Kevin N. Barnes, Robert Bryant, Robert Fox, Nancy Holloway, and Fred Draughon of Langley Research Center. For further information, contact the Langley Innovative Partnerships Office at (757) 864-8881. LAR-16503

Lightweight Radiator System for a Spacecraft

Three documents describe various aspects of a proposed lightweight, deployable radiator system for dissipating excess heat from the life-support system of a habitable spacecraft. The first document focuses on a radiator tube that would include a thin metal liner surrounded and supported by a thicker carbon-fiber-reinforced composite tubular structure that, in turn, would be formed as part of a unitary composite radiator-fin structure consisting mostly of a sheet of reticulated vitreous carbon laminated between carbon-fiber-reinforced face sheets. The thermal and mechanical properties, including the anisotropies, of the component materials are taken into account in the design. The second document describes thermo-structural bumpers, in the form of exterior multiple-ply carbon-fiber sheets enclosing hollows on opposite sides of a radiator fin, which would protect the radiator tube against impinging micrometeors and orbital debris. The third document describes a radiator system that would include multiple panels containing the aforementioned components, among others. The system would also include mechanisms for deploying the panels from compact stowage. Deployment would not involve breaking and remaking of fluid connections to the radiator panels.

This work was done by Robert J. Copeland, Georgia Mason, and Mark M. Weislogel of TDA Research, Inc., for Johnson Space Center. For further information, contact the Johnson Technology Transfer Office at (281) 483-3809. MSC-23252/3/4

Heated-Pressure-Ball Monopropellant Rocket Engine

A recent technology disclosure presents a concept for a monopropellant thermal spacecraft thruster that would feature both the simplicity of a typical prior pressure-fed propellant supply system and the smaller mass and rela-

tive compactness of a typical prior pump-fed system. The source of heat for this thruster would likely be a nuclear-fission reactor. The propellant would be a cryogenic fluid (a liquefied low-molecular-weight gas) stored in a tank at a low pressure. The propellant would flow from the tank, through a feedline, into three thick-walled spherical tanks, denoted pressure balls, that would be thermally connected to the reactor. Valves upstream and downstream of the pressure balls would be operated in a three-phase cycle in which propellant would flow into one pressure ball while the fluid underwent pressurization through heating in another ball and pressurized propellant was discharged from the remaining ball into the reactor, wherein it would be further heated, the propellant would be discharged through an exhaust nozzle to generate thrust. A fraction of the pressurized gas from the pressure balls would be diverted to maintain the desired pressure in the tank.

This work was done by William D. Greene of Marshall Space Flight Center. Further information is contained in a TSP (see page 1).

This invention is owned by NASA, and a patent application has been filed. For further information, contact Sammy Nabors, MSFC Commercialization Assistance Lead, at sammy.a.nabors@nasa.gov. Refer to MFS-32102-1.

Improved Emergency Egress Lighting System for the ISS

Emergency lights provide illumination in corridors, stairwells, ramps, escalators, aisles, and exit passageways during power failures. Safety and visibility are critical during a power outage. If emergency lights fail to operate properly, the building occupants can become disoriented. Four documents in a collection discuss different topics relating to a proposed improved emergency egress lighting system (EELS) for the International Space Station (ISS). While the present EELS is designed around rows of green-light-emitting diodes, the proposed system contains strips of electroluminescent tape using different colors for each egress path. The proposed EELS can be powered by the same battery currently used by the present EELS, but would require an inverter because electroluminescent devices require AC. Electroluminescent devices also require significantly less current and, depending

on the color, would emit 3 to 8 times the light of the present EELS. In addition, they could operate for up to 75 hours (versus ≈ 20 minutes for the present system). The first document contains a one-page summary of the proposal and an evaluation of technical merit. The second document summarizes the motivation for, and the design of, the proposed EELS. The third document addresses relevant aspects of the measurement of spectral sensitivity and the psychophysics of perception of light. The fourth document presents additional background information and technical specifications for the electroluminescent tapes.

This work was done by Leslie L. Eaton and Don A. Barr of GHG Corp. for Johnson Space Center. For further information, contact the Johnson Technology Transfer Office at (281) 483-3809. MSC-23431

Spacecraft Solar Sails Containing Electrodynamic Tethers

A report discusses a proposal to use large, lightweight solar sails embedded with electrodynamic tethers (essentially, networks of wires) to (1) propel robotic spacecraft to distant planets, then (2) exploit the planetary magnetic fields to capture the spacecraft into orbits around the planets. The purpose of the proposal is, of course, to make it possible to undertake long interplanetary missions without incurring the large cost and weight penalties of conventional rocket-type propulsion systems. Through transfer of momentum from reflected solar photons, a sail would generate thrust outward from the Sun. Upon arrival in the vicinity of a planet, the electrodynamic tethers would be put to use: Motion of the spacecraft across the planetary magnetic field would induce electric currents in the tether wires, giving rise to an electromagnetic drag force that would be exploited to brake the spacecraft for capture into orbit. The sail with embedded tethers would be made to spin to provide stability during capture. Depending upon the requirements of a particular application, it could be necessary to extend the tether to a diameter greater than that of the sail.

This work was done by Les Johnson of Marshall Space Flight Center and Greg Matloff of New York City Technical College, The City University of New York (CUNY). Further information is contained in a TSP (see page 1). MFS-31503



Advanced Metal Foam Structures for Outer Space

A document discusses a proposal to use advanced materials — especially bulk metallic glass (BMG) foams — in structural components of spacecraft, lunar habitats, and the like. BMG foams, which are already used on Earth in some consumer products, are superior to conventional metal foams: BMG foams have exceptionally low mass densities and high strength-to-weight ratios and are more readily processable into strong, lightweight objects of various sizes and shapes. These and other attractive properties of BMG foams would be exploited, according to the proposal, to enable *in situ* processing of BMG foams for erect-

ing and repairing panels, shells, containers, and other objects. The *in situ* processing could include (1) generation of BMG foams inside prefabricated deployable skins that would define the sizes and shapes of the objects thus formed and (2) thermoplastic deformation of BMG foams. Typically, the generation of BMG foams would involve mixtures of precursor chemicals that would be subjected to suitable pressure and temperature schedules. In addition to serving as structural components, objects containing or consisting of BMG foams could perform such functions as thermal management, shielding against radiation, and shielding against hypervelocity impacts of micrometeors and small debris particles.

This work was done by Jay Hanan of NASA's Jet Propulsion Laboratory, William Johnson of Caltech, and Atakan Peker of LiquidMetal Technologies. Further information is contained in a TSP (see page 1).

In accordance with Public Law 96-517, the contractor has elected to retain title to this invention. Inquiries concerning rights for its commercial use should be addressed to:

*Innovative Technology Assets Management
JPL*

*Mail Stop 202-233
4800 Oak Grove Drive
Pasadena, CA 91109-8099
(818) 354-2240*

E-mail: iaoffice@jpl.nasa.gov

Refer to NPO-41102, volume and number of this NASA Tech Briefs issue, and the page number.

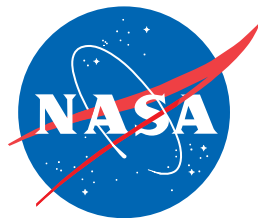

National Aeronautics and
Space Administration