

Abstract – Specialized Environmental Chamber Test Complex User Test Planning Guide

Test process, milestones and inputs are unknowns to first-time users of the Specialized Environmental Test Complex. The User Test Planning Guide aids in establishing expectations for both NASA and non-NASA facility customers. The potential audience for this guide includes both internal and commercial spaceflight hardware/software developers. It is intended to assist their test engineering personnel in test planning and execution. Material covered includes a roadmap of the test process, roles and responsibilities of facility and user, major milestones, facility capabilities, and inputs required by the facility. Samples of deliverables, test article interfaces, and inputs necessary to define test scope, cost, and schedule are included as an appendix to the guide.

Specialized Environmental Chamber Test Complex

User Test Planning Guide

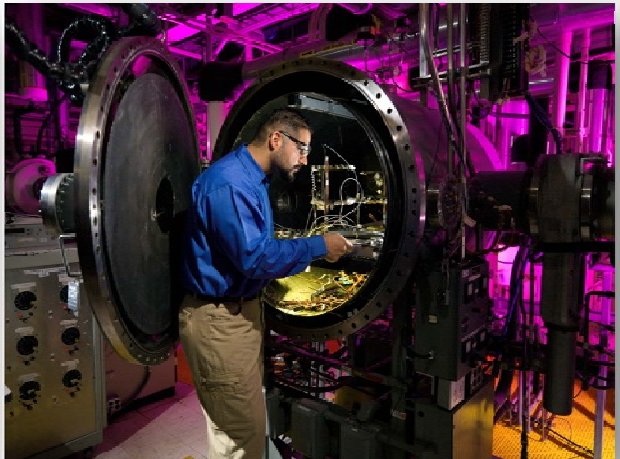
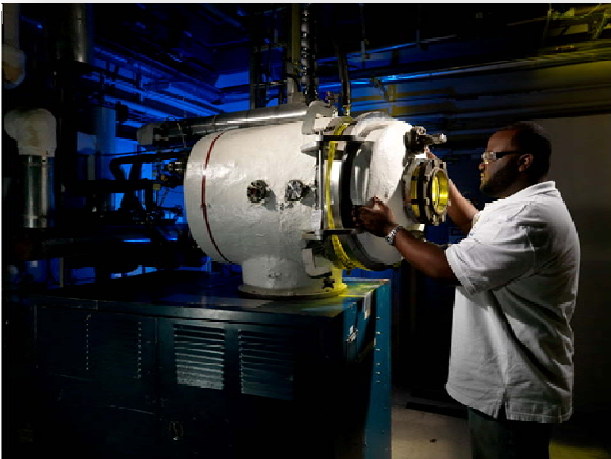
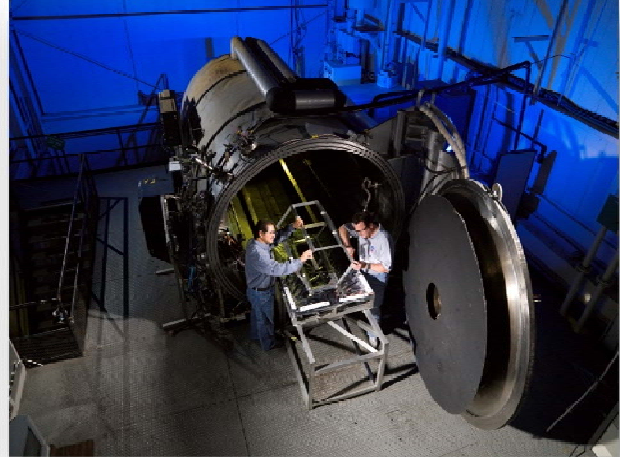

National Aeronautics and Space Administration
Lyndon B. Johnson Space Center
Houston, Texas 77058

Table of Contents

1.0	Specialized Environmental Chamber Test Complex.....	3
2.0	Facility Layout	4
3.0	Safety and Health.....	5
4.0	Test Process Flow	5
4.1	Export Controlled and Proprietary Information.....	6
4.2	Test Initiation Phase	7
4.2.1	Test Request.....	7
4.3	Test Preparation Phase	8
4.3.1	Test Requirements	8
4.3.2	Schedule and Cost Estimate	9
4.3.3	Test Article Documentation	9
4.3.4	Test Plan	9
4.3.5	Test Schedule	10
4.3.6	Test Article Delivery.....	10
4.3.7	Test Readiness Review.....	10
4.4	Test Execution Phase	11
4.4.1	Test Authority	11
4.4.2	Quality Assurance	11
4.4.3	Test Deviations.....	12
4.4.3	Facility Equipment	12
4.5	Test Closeout Phase.....	12
4.5.1	Data Package.....	12
4.5.2	Customer Feedback.....	13
5.0	Facility Access	14
6.0	Roles and Responsibilities	15
	Acronyms	16
	Appendices	17
Appendix A	Facility Interfaces and Test Configurations	18
Appendix B	Test Request Worksheet.....	27
Appendix C	Example Test Request Worksheet.....	33
Appendix D	Instrumentation Provided by Facility	40
Appendix E	Customer Feedback.....	41

1.0 Specialized Environmental Chamber Test Complex

Johnson Space Center's (JSC's) Specialized Environmental Chamber Test Complex provides thermal vacuum and ambient temperature chamber test operations for unmanned test environments. The facility offers a wide range of performance capabilities, which can be matched to the individual test requirements of smaller test articles or large test article components and subsystems. Typical uses of these chambers have included development; engineering evaluation and qualification testing of spacecraft components, subassemblies, and experiments; preflight thermal-vacuum conditioning of flight hardware; development and calibration of instruments for use in the large chambers or in flight; spacecraft seal studies; photographic film emulsion studies; and optical surface contamination studies.

Services Provided

- Environmental cycling for materials survivability
- Materials and hardware testing in extreme environments
- Determination of design factors
 - Operating temperatures
 - Combined thermal and pressure-load distortions of dimensionally critical structural elements
 - Fluid/gas leak rates
 - Changes in absorptive or emissive properties of thermal coating
 - Evolution of harmful or undesirable off-gassing products
 - Presence of conditions conducive to electrical-arc or corona discharge
 - Properties of lubricating films and surfaces
- Hardware bakeouts
- Drop testing in thermal/vacuum environment
- Thermal control system performance
- Accelerated electrical/electronic component burn-ins and life cycle testing



Point of Contact

Lab Manager, Michael Montz
 Johnson Space Center
 2101 NASA Parkway, Houston, TX 77058
 (281) 483-9148
michael.e.montz@nasa.gov

Specifications

Facility	Internal Volume (ft.)	Temperature Range	Pressure Range
Chamber E	4.6' Dia x 9.5' L	~280 °F – *	1 x 10 ⁻⁶ – 760 torr
Chamber N	3' Dia x 3' L	~280 °F – *	1 x 10 ⁻⁶ – 760 torr
Chamber P	5' Dia x 4' L	Ambient – 400 °F	1 x 10 ⁻⁶ – 760 torr
Chamber G	1.4' Dia x 2' L	~280 °F – *	1 x 10 ⁻⁶ – 760 torr
Chamber H	8' W x 8' H x 15' Dia	~150 – 200 °F	N/A
Chamber K	3' W x 3' H x 3' Dia	~250 – 350 °F	N/A
Chamber L	3' W x 3' H x 3' Dia	20 – 200 °F	N/A
Chamber T	27" W x 30" H x 27" Dia	~250 – 350 °F	N/A

* Material dependent

2.0 Facility Layout *

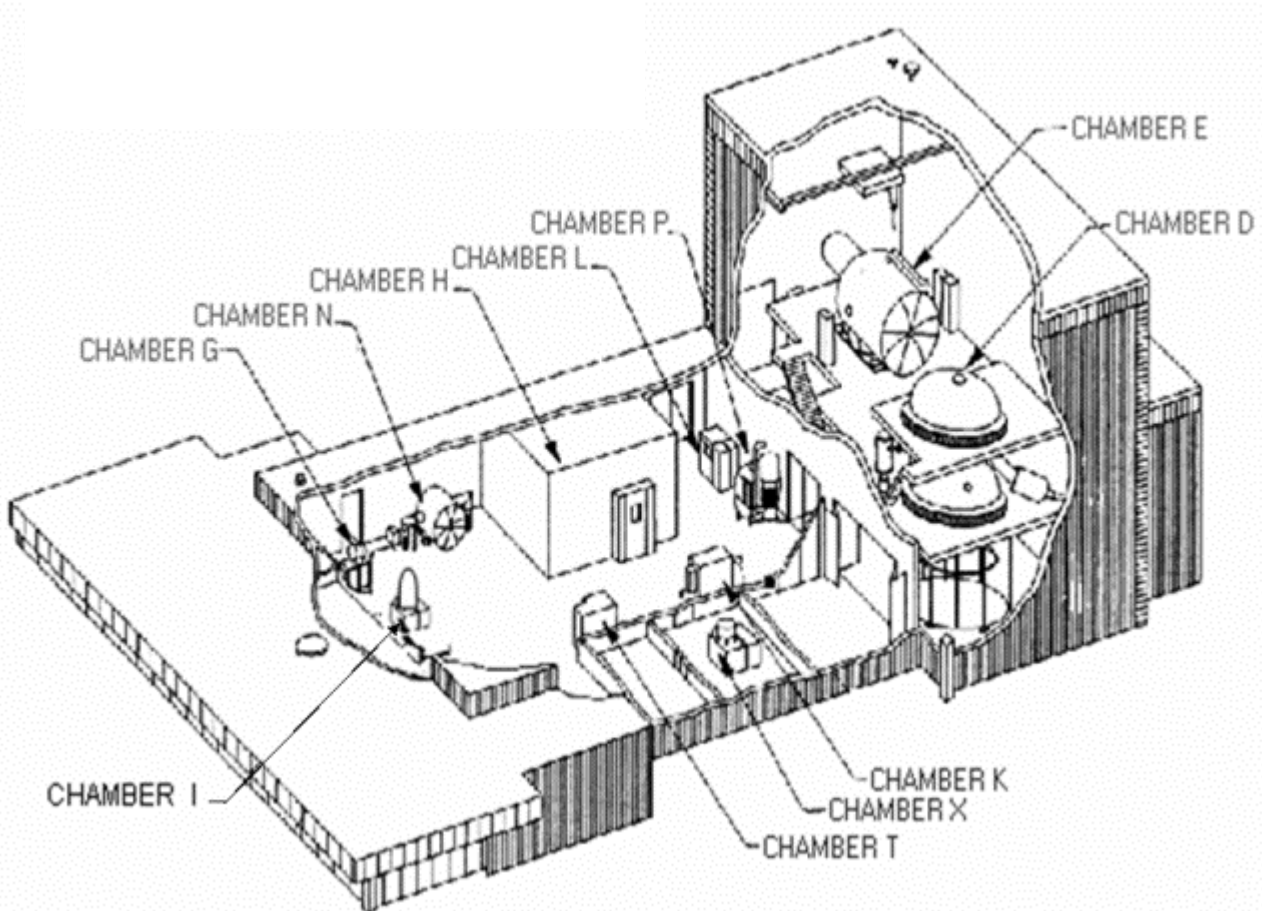

* See Appendix A for a sample facility interface and sample test configurations.

3.0 Safety and Health

Safety is an integral part of the culture at the National Aeronautics and Space Administration (NASA). Management, leadership, and employee involvement from all organizations are critical to the success of NASA’s safety program. In order to ensure personal safety and a safe test environment throughout the process, the requester shall furnish the facility with the information necessary to perform a hazard assessment of the test article. Additionally, while visiting JSC, the requester shall follow all facility-specific safety and health requirements. A facility safety briefing shall be provided to all personnel prior to the start of the test.

4.0 Test Process Flow

The flowchart presented below outlines the basic roadmap and significant milestones between the initial test request and delivery of test data. The flow is separated between Test Requester actions and Facility actions, highlighting interactions and inputs between the Test Requester and the facility Test Director.

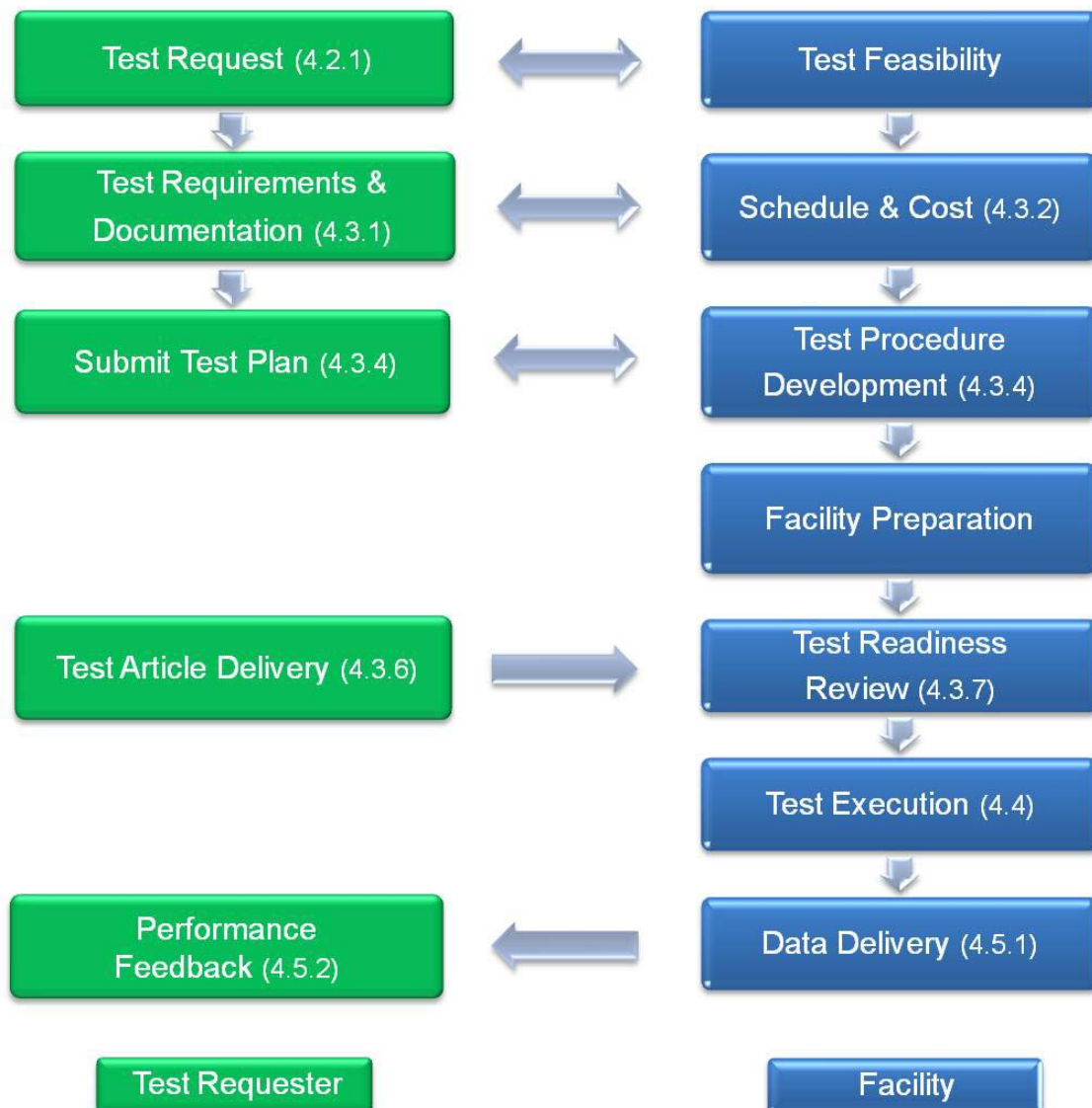

The test schedule is highly dependent on the complexity of the test, facility availability, and sequence of runs. For time-critical testing, this schedule may be accelerated. A detailed schedule shall be developed following review of test objectives and requirements. Major milestones are presented below:

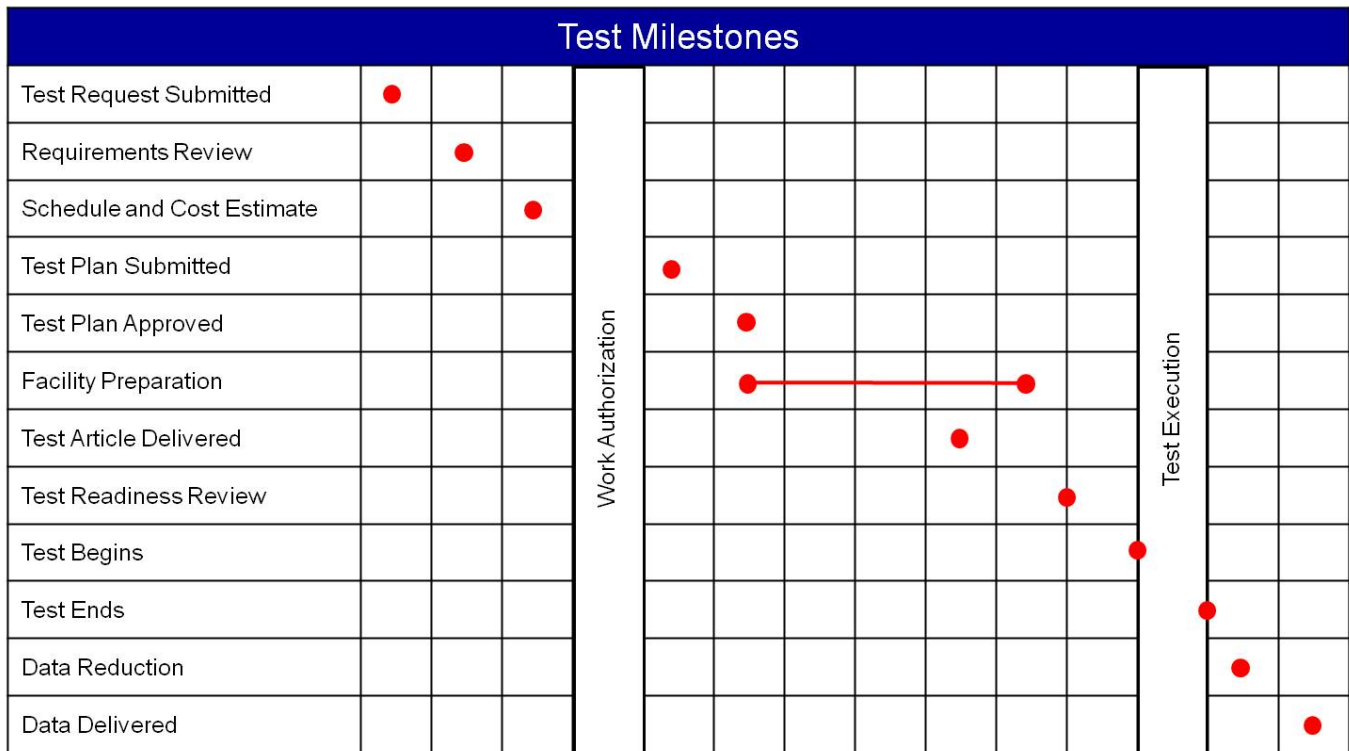

4.1 Export Controlled and Proprietary Information

JSC provides for protection of export controlled and proprietary information and hardware throughout the test process. The Test Requester shall clearly mark all export controlled or proprietary hardware items and data provided with a notice of restriction on disclosure or usage. The Test Director shall safeguard export controlled or proprietary items from unauthorized use and disclosure and ensure that test articles remain secure within the facility and are properly sequestered. Access to the facility is restricted to facility personnel and escorted visitors. Hardware items shall be returned to the Test Requester or disposed of in accordance with the Test Requester’s instructions at the completion of the test activity.

4.2 Test Initiation Phase

The test initiation phase establishes the relationship between the Test Requester and the Test Director. The Test Requester shall provide a test request to the Test Director, which will be used to determine test feasibility and to develop an estimated cost and a preliminary test schedule. An initial requirements review meeting may be necessary in order to discuss the characteristics of the test article, the test objectives, or any special considerations for the test. An onsite tour of the facility is highly recommended for familiarization and to provide an opportunity for an exchange of technical information.

Inputs: Test Requester provides test request, identifies Test Article Expert

Activities: Test Director reviews test request to determine test feasibility

Outputs: Facility delivers preliminary test plan, estimated cost, and schedule to Test Requester

4.2.1 Test Request

The test request outlines the test objectives, test article description, and schedule. A Test Request Worksheet is provided in Appendix B. This worksheet addresses the basic requirements for testing in the Specialized Environmental Chamber Test Complex. It is suggested that the Test Requester complete this worksheet to facilitate the development of a preliminary cost and schedule estimate. Contact the Test Director if you have questions about completing the Test Request Worksheet. Internal Test Requesters should also submit a JSC Form 90, Test Request Form, to the Test Director. This form is used by JSC as a formal means of requesting a test within JSC. It is the work authorizing document for the test team to provide support. JSC personnel will complete the Test Request Form (Form 90) for external Test Requesters.

At a minimum, the test request should include the following information:

Test Objective

A brief description of the test requirements including, but not limited to, the following:

- Desired test conditions (pressure, temperature, exposure time)
- Proposed test approach
- Test data requirements

Test Article Description

A brief description of the test article including, but not limited to, the following:

- Size (provide drawings, sketches, photos)
- Weight
- Test article interface (load points, method of suspension or test article support)
- Test article fluid interface requirements (type, pressure, flow)
- Orientation (fixed or moveable)
- Special considerations [e.g., hazards, cleanliness, compatibility, Material Safety Data Sheets (MSDS)]
- Handling and storage requirements

Schedule

Identify the required start date and proposed date for test completion.

4.3 Test Preparation Phase

The detailed test plan and test schedule are finalized during the test preparation phase. The Test Requester shall provide detailed test requirements and test article documentation to the Test Director. A Test Readiness Review (TRR) will be held following approval of the test plan.

Inputs:	Test Requester provides test requirements, test plan, and test article documentation
Activities:	Facility develops test procedure, begins assembly of facility interface/support structure(s) Test Requester ships/ transports test article to JSC
Outputs:	Test Requester approves test plan/procedure and final test schedule Facility holds TRR

4.3.1 Test Requirements

A complete understanding of test requirements is mandatory for a successful test. Test requirements must be defined and reviewed so that the test team understands the effect of the requirements on test facility preparation. The Test Requester shall provide a detailed list of test requirements including, but not limited to, the following:

- Specific test conditions
- Interface requirements (e.g., fluid, structural, electrical, mechanical)
- Data/instrumentation requirements (e.g., data type, data format, number of channels, sample rate)

4.3.2 Schedule and Cost Estimate

Following review of the test requirements, the Test Director will provide a cost and schedule estimate, including major milestones, to the Test Requester. The cost estimate is highly dependent on the level of detail provided for the test requirements.

4.3.3 Test Article Documentation

Test Article Drawings

The Test Requester shall provide detailed test article drawings as requested by the facility. Test article drawings are used to prepare the facility interfaces, test article support structures, and instrumentation connection points.

Material Safety Data Sheets

NASA must ensure that all materials exposed to test environments do not present a hazard to personnel or the test facility. The Test Requester shall deliver MSDS for materials used in the construction of the test article with an assessment of expected byproducts produced during the thermal test. The MSDS shall be delivered prior to delivery of the test article. The Test Director will review the materials list for compatibility with the test environment and to determine protective measures for personnel, if required.

Materials Usage Control Board

Test article materials for which an MSDS does not exist will be reviewed by the Materials Usage Control Board (MUCB). The MUCB is responsible for reviewing the proposed usage and for accepting or rejecting the material, based on information available on material characteristics and applications and information supplied by the Test Requester.

Test Article Hazard Identification

The safety of facility personnel, facility equipment, and the test article is imperative to NASA. Potential hazards, material compatibility, and facility interfaces will be reviewed with the facility prior to testing. In certain instances, special precautions must be taken due to the severity level of these potential hazards. The Test Requester may be asked to provide further information to clarify or mitigate a potential hazard. A test article hazards checklist is provided in Appendix B.

4.3.4 Test Plan

A test plan shall be submitted by the Test Requester. A test plan is necessary to ensure that all requirements of the Test Requester and the facility are achieved in an efficient and reproducible manner. The test plan is instrumental in developing the detailed test procedure. The final test plan shall be approved by the Test Requester with concurrence from the Test Director. The test plan will be the controlling document, with respect to scope and approach for the test program. The test plan will include, at a minimum, the test objectives, scope, test article description,

safety considerations, and data requirements. Changes to the test plan that occur after the TRR that result in a major change to the scope of the test or that present new hazards may require a delta TRR.

4.3.5 Test Schedule

A detailed schedule shall be developed by the Test Director and approved by the Test Requester. The schedule shall allow adequate time for review and approval of test requirements, assembly of facility interfaces/structures, and delivery of the test article. The schedule of other tests and maintenance activities will be reviewed and potential conflicts shall be addressed by the Test Director.

4.3.6 Test Article Delivery

The test article delivery date will be determined on a case-by-case basis. An agreed-upon delivery date shall be captured as a milestone in the test schedule. The Test Requester shall provide detailed handling instructions prior to delivery of the test article, including handling hazards, cleanliness, and storage requirements. The test article shall be secured within the test facility, unless directed to provide another means of storage. An inspection of the test article shall be performed by the Test Director and the Test Article Expert prior to the start of testing. NASA encourages Test Article Expert participation in the test article integration phase to provide immediate feedback on test article handling and on any integration issues that arise.

4.3.7 Test Readiness Review

A TRR will be held to ensure the completion of all necessary facility and test article activities prior to test execution. The Test Requester shall submit documentation to the Test Readiness Review Board (TRRB), declaring that the test article is ready and there is no constraint to test. This is required to verify that there are no issues that would invalidate the test. The TRR Summary Sheet (Form 1850) is one version of such documentation for internal Test Requesters. The Test Director will provide instructions for submitting test hardware readiness documentation.

The TRR will include the following:

- Review of the test plan, test procedures, and other required test documentation
- Confirmation of facility and test article readiness
- Review of configuration records, including facility interface control documents, pressure system certification, instrumentation calibration, and materials compatibility
- Assurance that controls are in place to mitigate risks or hazards identified in the test hazard analysis

- Verification that data acquisition and processing functions are in place to adequately capture all critical data
- Confirmation that multimedia coverage is adequate to provide recognition and assessment of potential test anomalies

Approval to proceed with test operations is granted by the TRRB. The Test Director shall ensure that all TRR actions have been accomplished prior to the start of the test. The TRRB shall convene 1 to 5 business days prior to the start of the test. TRRB participants shall include the following:

NASA TRRB Chairman	Test Article Expert (Appointed by Test Requester)
Test Director	Systems Safety Engineer
NASA Test Safety Officer	Quality Engineer – if required by facility

4.4 Test Execution Phase

NASA encourages Test Requester participation in the testing activity. The Test Requester shall provide a Test Article Expert to verify that test setup and execution meet the stated objectives. The Test Article Expert also shall verify test article performance and approve requested test deviations during test operations. In some cases, the Test Director may be designated as the Test Article Expert.

Inputs:	Approval to begin testing received from TRRB
Activities:	Facility completes facility buildup, Detailed Test Procedure Facility conducts testing activity
Outputs:	Test completed

4.4.1 Test Authority

The Test Director has the authority and responsibility to direct the test in accordance with the approved test plan and to terminate test activities per test rules when danger is imminent or test control cannot be maintained. The Test Director will ensure that positive actions are taken to halt any steps in the test procedure whenever unsafe or hazardous test conditions arise. The Test Director, with the concurrence of the Test Article Expert, has the authority to terminate the test when sufficient data has been obtained to meet objectives or when objectives cannot be met. Test team personnel will accept directions only from the Test Director.

4.4.2 Quality Assurance

Quality Assurance has the responsibility to verify that the test facility is ready for the test by assuring that all constraints to the test have been closed or non-constrained. For testing of controlled hardware, Quality Assurance is available to verify that the test article has successfully passed all functional acceptance, qualification, or certification requirements. Quality Assurance

will prepare a discrepancy report or material review record to document a nonconformance if the test article or equipment fails or deviates from specified limits. Quality Assurance is also available to monitor qualification and certification tests to ensure that approved test plans and procedures are used, equipment records are maintained, test tools are within calibration, inspection check points are completed, and nonconformance's are documented. Please consult with the Test Director to determine the level of Quality Assurance support required for the test.

4.4.3 Test Deviations

Changes to the test procedure shall be approved by the Test Article Expert with concurrence from the Test Director. Deviations that result in a major change to the scope of the test or that present new hazards may require a delta TRR.

4.4.4 Facility Equipment

The facility equipment is meant for use by JSC personnel. Prior arrangements shall be made with the Test Director for potential use of this equipment by the Test Requester. The duration and type of use will be identified prior to authorization for use. JSC workstations are not available for use by Test Requester personnel. This is necessary to protect the integrity of the facility. The Test Requester shall make prior arrangements with the Test Director if a dedicated workstation is required during testing. The Test Requester is encouraged to bring a laptop for use during the test. Wireless Internet access is available in the facility.

4.5 Test Closeout Phase

Data shall be delivered to the Test Requester within 10 business days following completion of testing. The Test Requester shall notify the Test Director upon receipt of the data. Acceptance of the test data concludes the test activity.

Inputs: Test completed

Activities: Facility ships/transport test article to Test Requester
Test Director delivers data to Test Requester

Outputs: Test Requester accepts data
Test Requester completes Customer Feedback form

4.5.1 Data Package

A data package is an assembly of test results. The format of the data package is normally specified by the Test Requester. The standard data package format includes a description of the test and objectives, test observations, and data plots.

4.5.2 Customer Feedback

JSC requests feedback from our customers. Evaluation of the services we provide enables continued improvement to our process. A Customer Feedback form is included in Appendix D. You are encouraged to complete the Customer Feedback form and return it to the Test Director, following receipt of the test data. Your participation is greatly appreciated.

5.0 Facility Access

Identification badges are required for all persons requiring access to JSC. The Test Director or designee will initiate a badge request for all Test Requester personnel who will be participating in the test activity. Badge requests must be submitted at least 4 days prior to the visit to prevent badge processing delays. Badge requests for non-U.S. citizens may require a minimum of 30 business days to process. Test Requester personnel shall arrive at JSC Building 110 to pick up temporary identification badges. Visitors to JSC must show a current picture identification (valid driver's license, U.S. passport, government ID card).

The Special Environmental Chamber Test Complex is located in JSC Building 33. A facility access briefing shall be provided to all personnel requiring access to the facility prior to the start of the test.

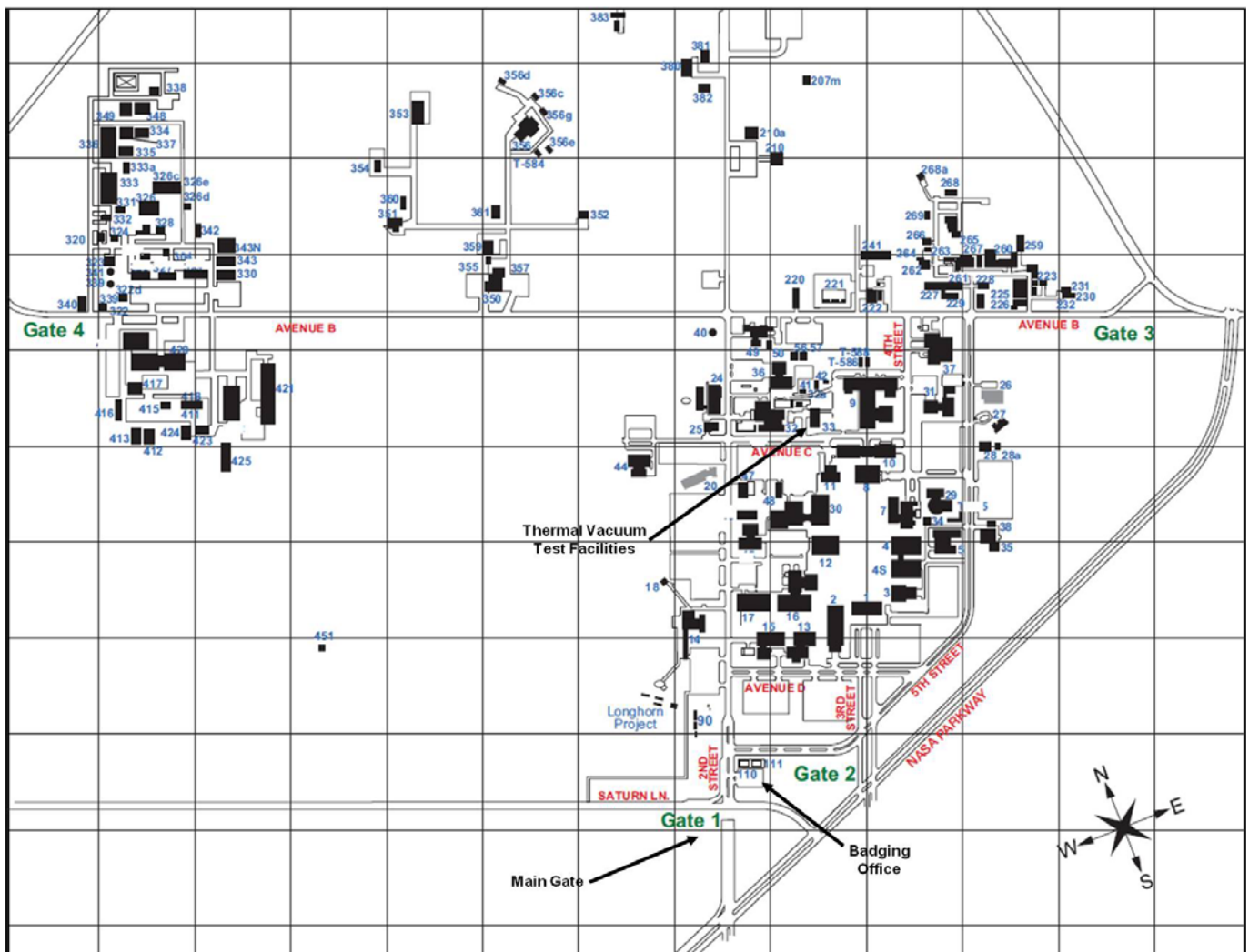

6.0 Roles and Responsibilities

Test Director – Has overall responsibility for all phases of the test process.

Test Requester – The client requesting performance of a test activity. The Test Requester is responsible for the test article and for providing a Test Article Expert.

Test Article Expert – A representative of the Test Requester with thorough knowledge of the test article and how it is to be operated in the test environment. The Test Article Expert also is responsible for approving the test plan and verifying that test objectives are met.

Facility Engineering – Responsible for designing and fabricating any required test article interfaces, including structures, fluids, and power. Facility engineering also provides support for external test article instrumentation and data acquisition.

Systems Safety Engineer – Reviews the test article hazard assessment and prepares an integrated hazard analysis for the test facility to identify any additional hazards that could result from mating the test article to the test facility.

Quality Engineer – Responsible for verifying that the test facility is ready for the test by ensuring that all constraints to the test have been closed or non-constrained.

Responsibilities Matrix

Item	Test Requester	Facility
Test Request Worksheet	Create	Review and provide assistance as needed
Cost and schedule	Approve	Create and sign off
Hazards	Identify test article hazards	Create test article/facility integrated hazard analysis
Test plan	Submit and approve	Review and approve
Detailed test procedure	Review and approve	Create and approve
Test hardware readiness document	Submit and approve	Review and approve
Test Readiness Review Board	Submit	Conduct and approve
Test execution	Verify test article performance	Execute test
	Verify that test setup and execution meet objectives	
	Approve requested deviations	
Provide test data/results	Notify Test Director of data receipt	Deliver to Test Requester
Review test data/results	Approve	
Shipping	Provide instruction	Execute per request

Acronyms

FS	Full Scale
IR	Infrared
JSC	Johnson Space Center
MSDS	Material Safety Data Sheets
MUCB	Materials Usage Control Board
NASA	National Aeronautics and Space Administration
PLSS	Primary Life Support System
RF	Radio Frequency
TRR	Test Readiness Review
TRRB	Test Readiness Review Board
UV	Ultraviolet

Appendices

- A. Facility Interfaces and Test Configurations
- B. Test Request Worksheet
- C. Example Test Request Worksheet
- D. Instrumentation Provided by Facility
- E. Customer Feedback

Appendix A Facility Interfaces and Test Configurations

The test fixture drawings included in this guide are a sampling of the capabilities within the Thermal Vacuum Test Facilities. The facility maintains a variety of fixtures to support general and requester-specific testing. Additional test fixture drawings are available upon request. The facility can manufacture test fixtures to requester specifications. Contact the Test Director to discuss test article interface requirements.

Chamber E

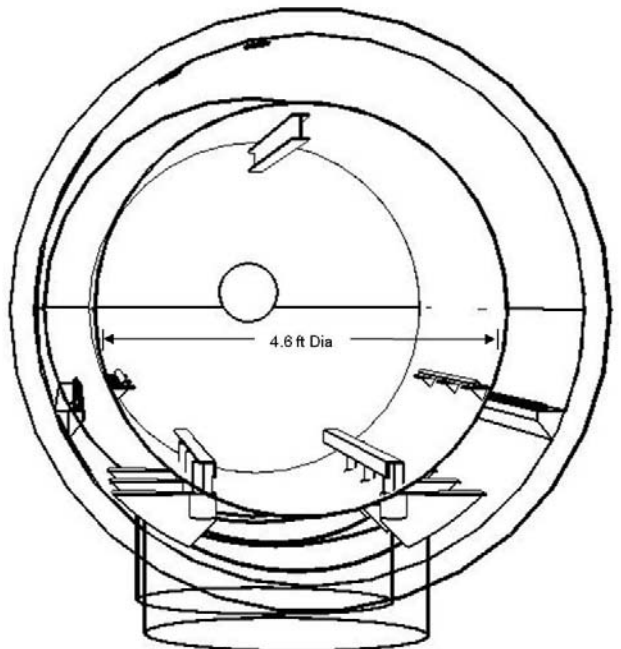
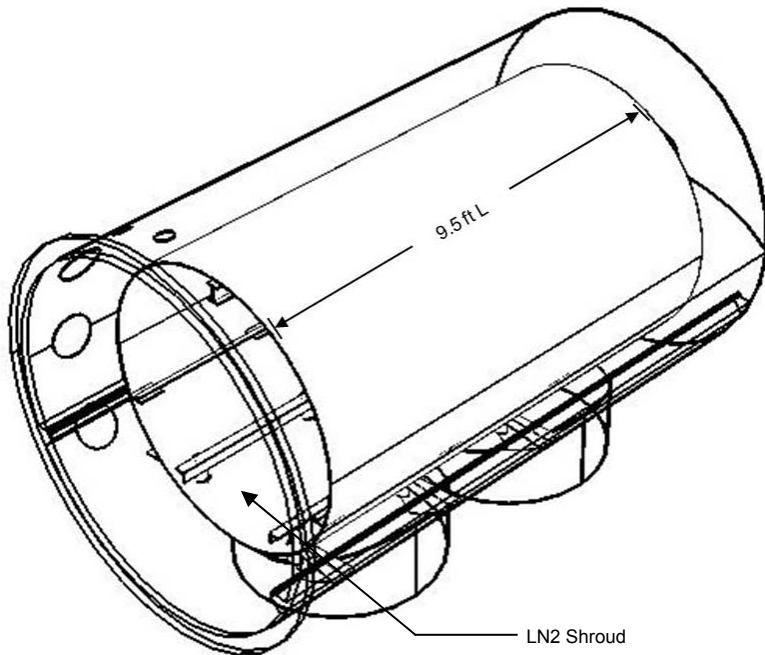

Specifications

Type	Values
Type of Pumps	Diffusion pumps for high vacuum
Pump Down Time	8 hr
Repressurization	Nitrogen or air
Full Chamber Shroud	Subcooled $-298\text{ }^{\circ}\text{F}$ LN ₂ shroud, 130,000 W total heat absorption capacity, 1,615 W/m ² (150 W/ft ²) maximum heat flux
Wall Emissivity	0.95
Usable Features	Large gas load capability due to oversized pumps

Chamber N

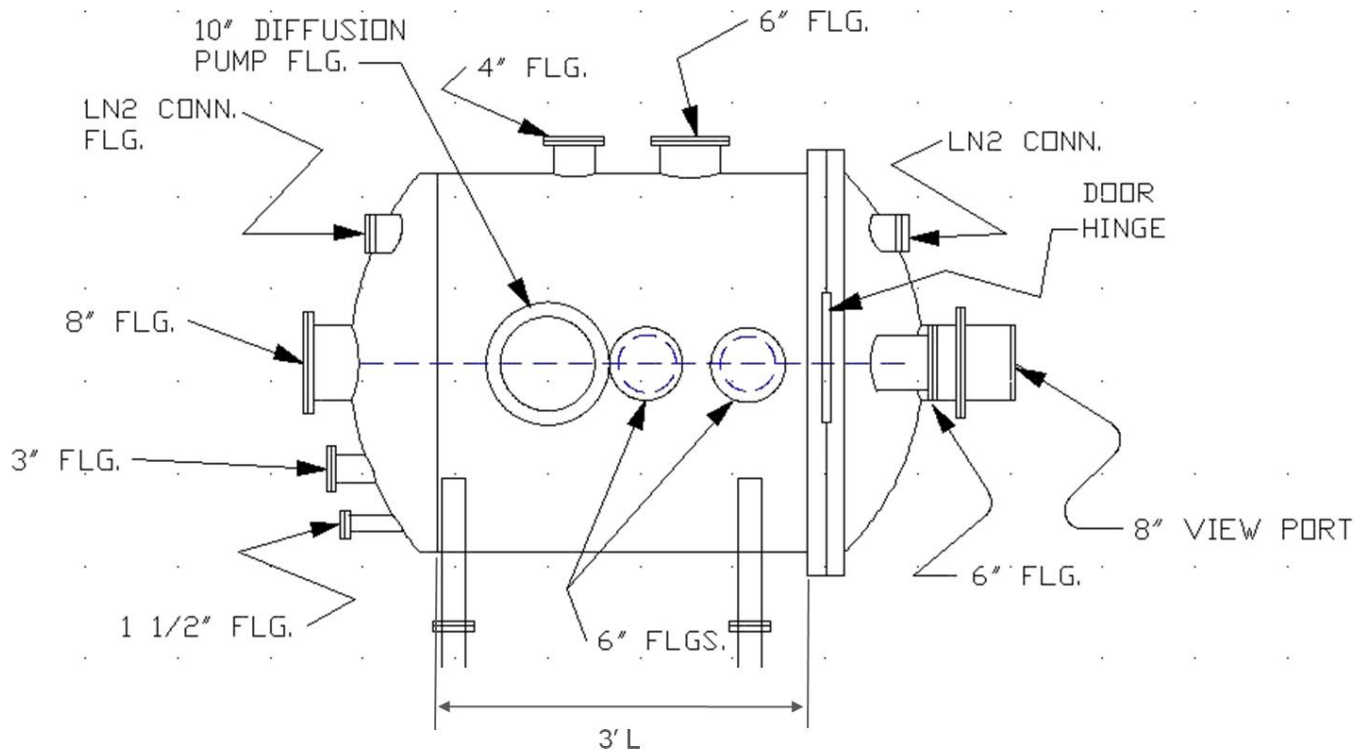

Front View

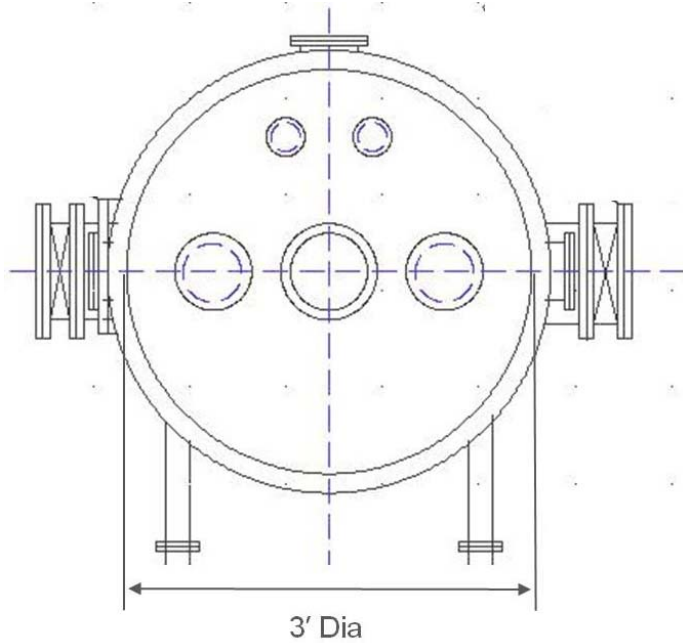

Specifications

Type	Values
Type of Pumps	1 roughing, 1 turbomolecular pump
Pump Down Time	4 hours to full cryo-pumping conditions
Full Chamber Shroud	Subcooled -280 °F LN ₂ shroud
Repressurization	Nitrogen or air
Usable Features	Turbomolecular pump (clean pumping); rotary and linear mechanical feed-throughs

Chamber P

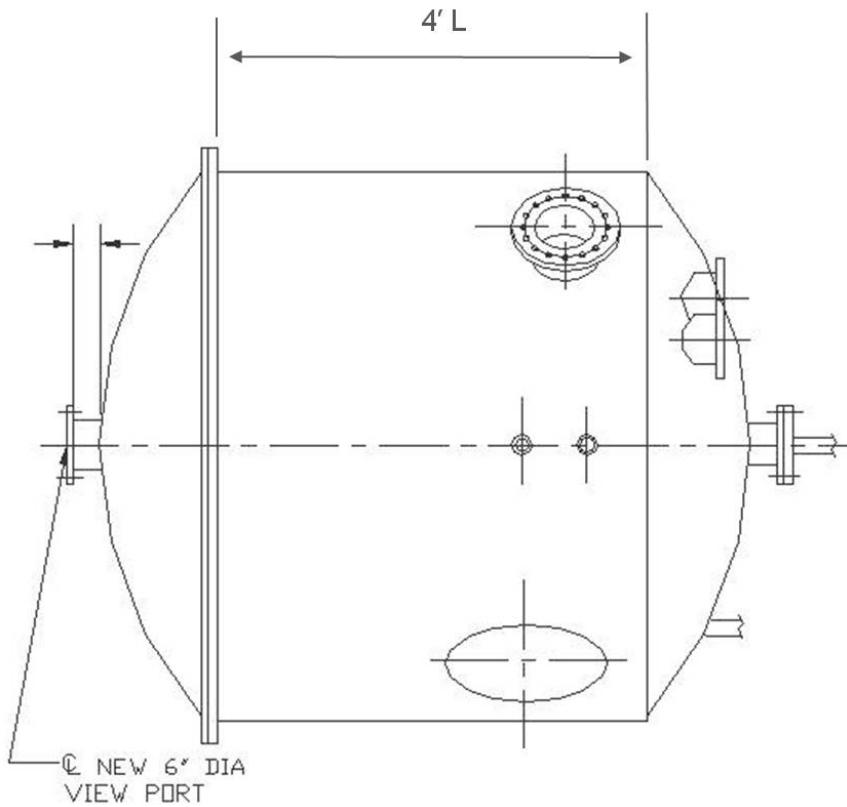

Front View

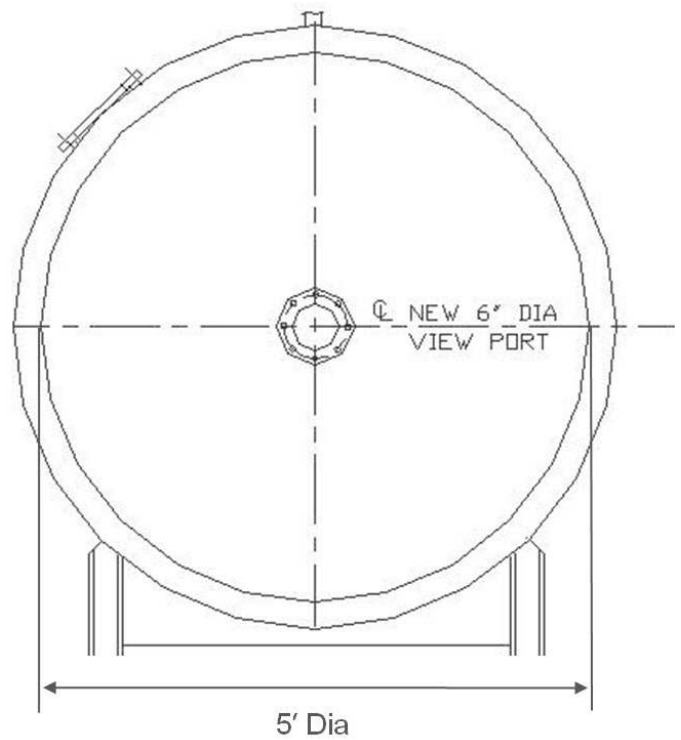

Specifications

Type	Values
Type of Pumps	1 roughing, 1 turbomolecular pump
Pump Down Time	1 hour
Temperature Range	Ambient: -400 °F
Usable Features	Automated for unattended off-gassing of materials, remotely controlled, scavenger plate for collecting contaminants, turbomolecular pump, sample bomb interface for outgas material collection and analysis

Chamber G

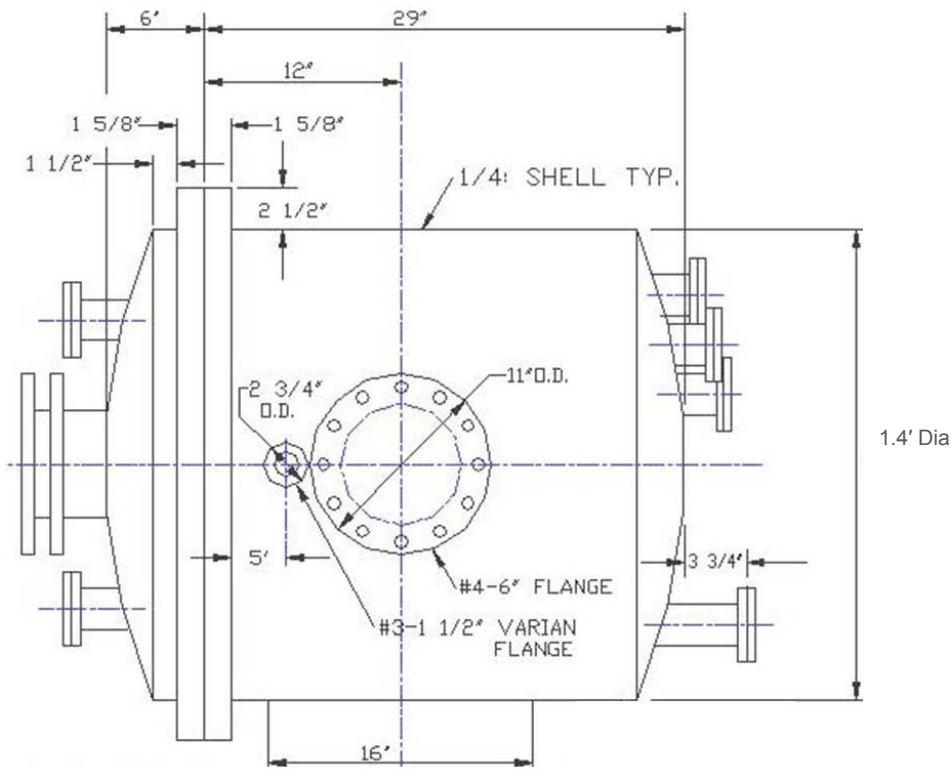

Front View

Specifications

Type	Values
Type of pumps	Diffusion pump for high vacuum
Pump down time	1 hour
Repressurization	Nitrogen or air
Temperature Range	-280 °F - *
Usable Features	Hot and cold GN ₂ mixing for shroud thermal control at temperature

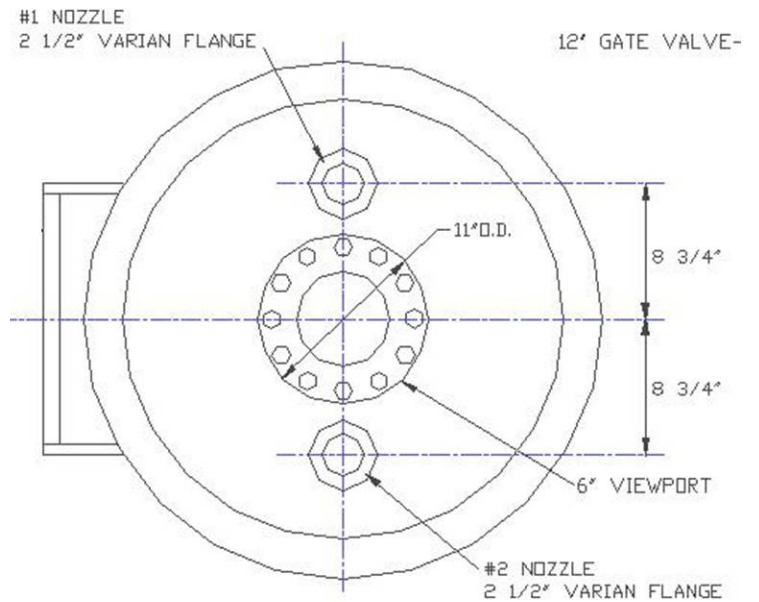

Chamber H

Specifications

Type	Values
Usable Dimensions	8' x 8' x 15'
Temperature Range	-150 – 200 °F
Cooling/Heating Rate	4 °F/minute
Access Door	70" x 82"
Observation Panels	2 windows
Glove ports	2 below each window
Feedthroughs	4" x 4"

Chamber L

Specifications

Type	Values
Usable Dimensions	3' x 3' x 3'
Temperature Range	20 – 200 °F
Humidity Range	30 – 98% relative humidity
Access	3' x 3' door

Chamber K

Top View

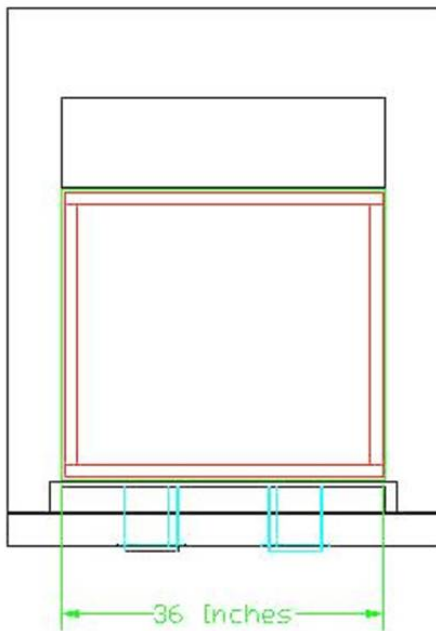

Unistrut Space frame shown as: _____

Test Volume shown as: _____

Specifications

Type	Values
Usable Dimensions	3' x 3' x 3'
Temperature Range	-100 – 350 °F
Maximum Rate of Ramp	5 °F/minute
Access	3' x 3' door
Observation Panel	1' x 1' window

Front View

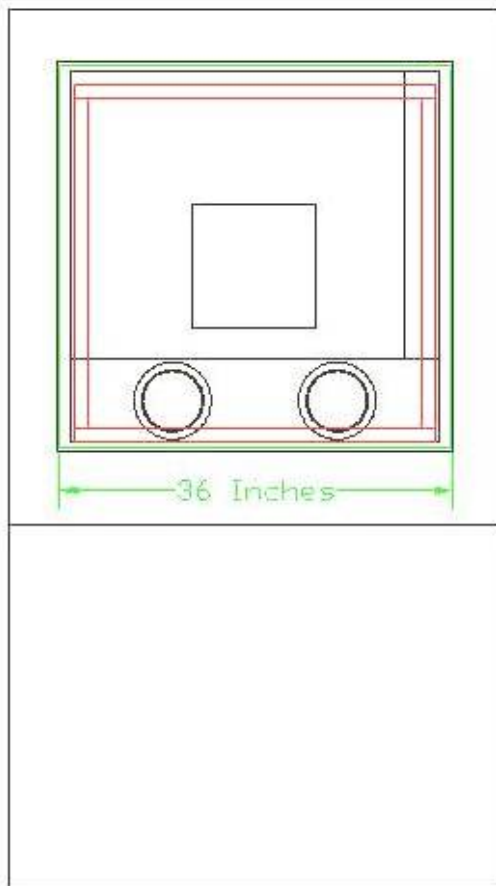

Side View

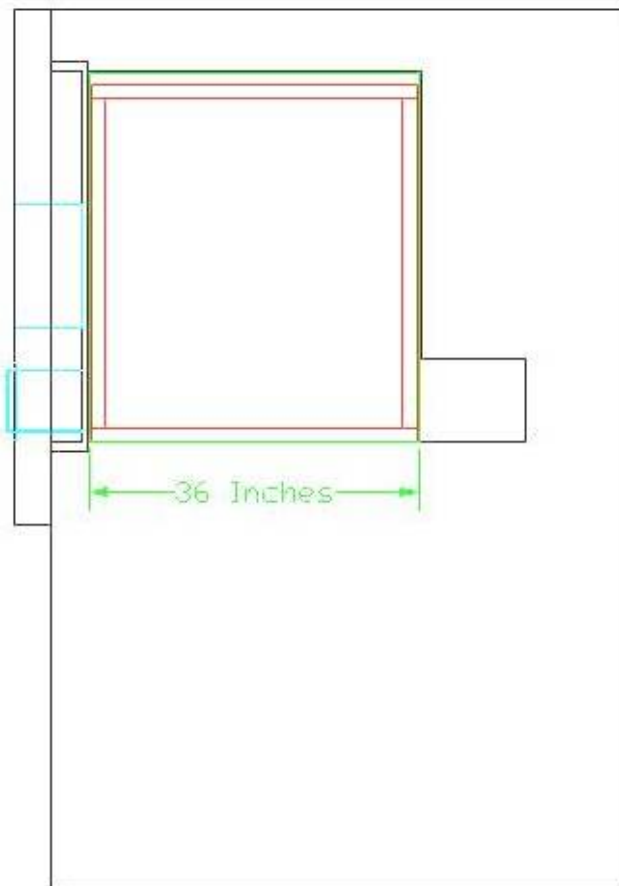

Chamber T

Front View

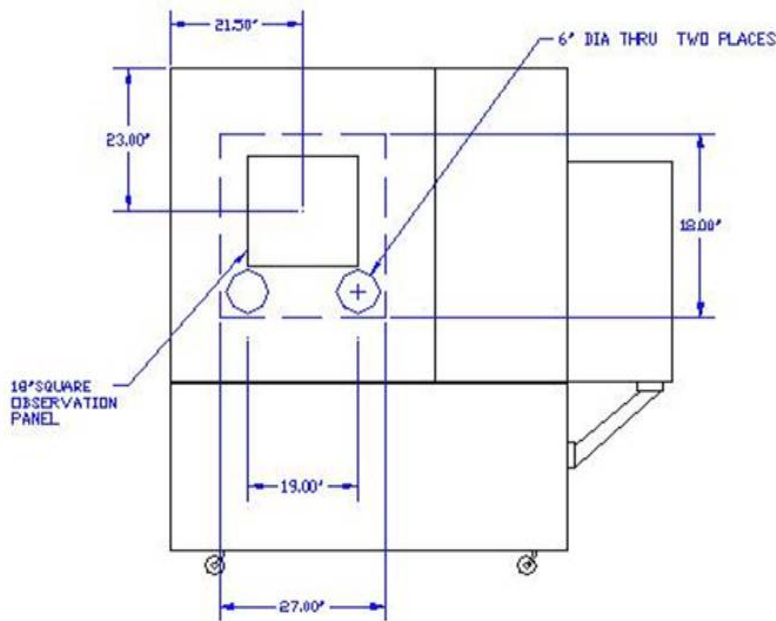

Specifications

Type	Values
Usable Dimensions	27" x 30" x 27"
Temperature Range	-250 – 350 °F
Cool Down Time	Ambient to -100 °F in 1 hour
Heat Up Time	Ambient to 200 °F in 1 hour
Access	27" x 30" door
Observation Panel	1.5' x 1.5' window
Feedthroughs	Two 4" square ports, six 0.625" diameter tubes

Right Side View

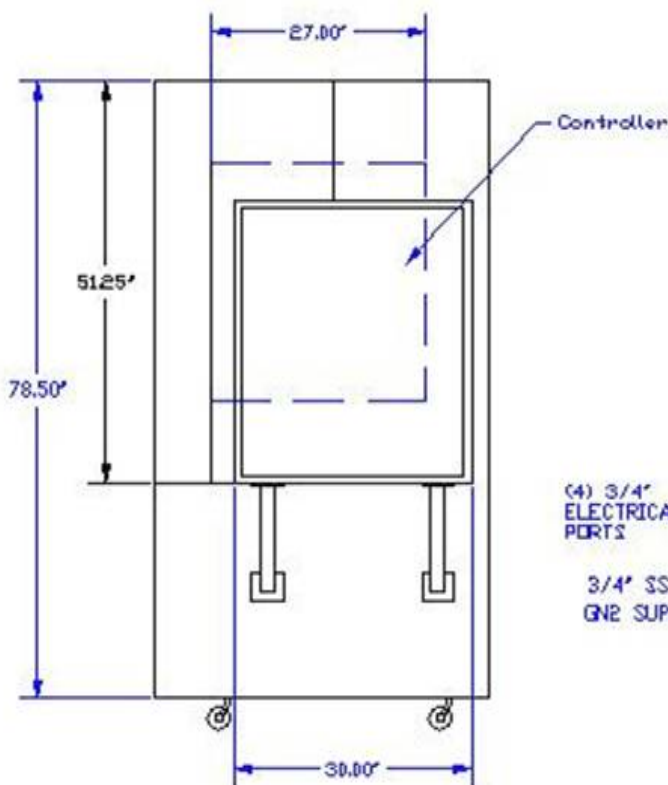

Left Side View

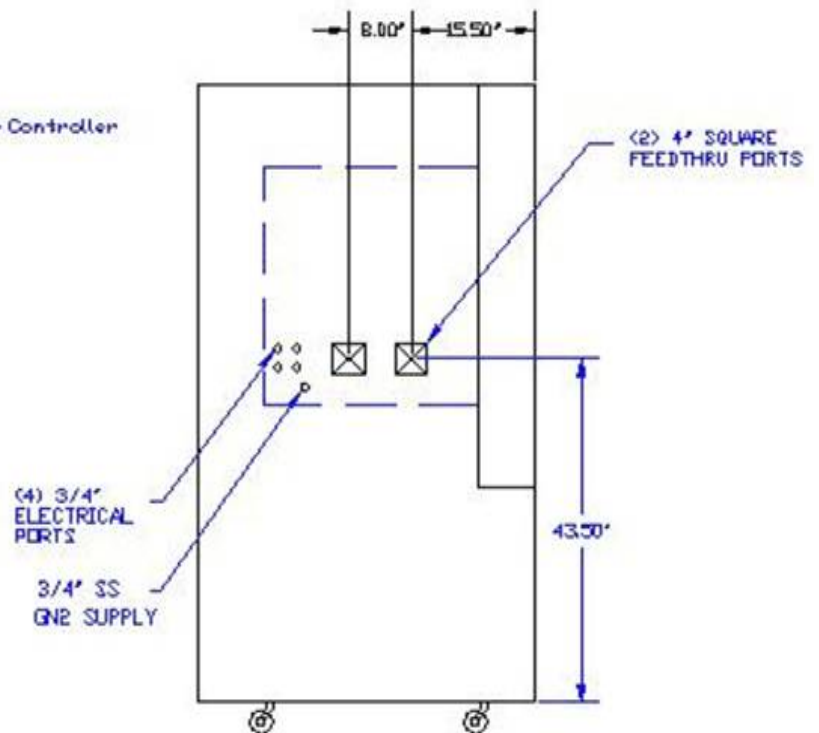

Test Configurations

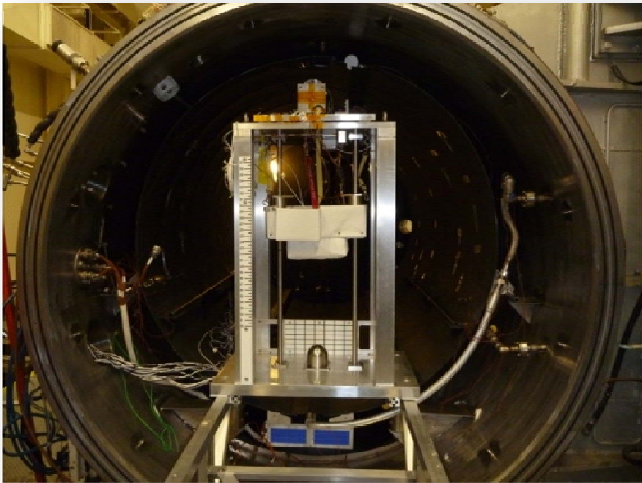

Primary Life Support System (PLSS)
Packaging Thermal Vacuum Impact
Evaluation – Chamber E

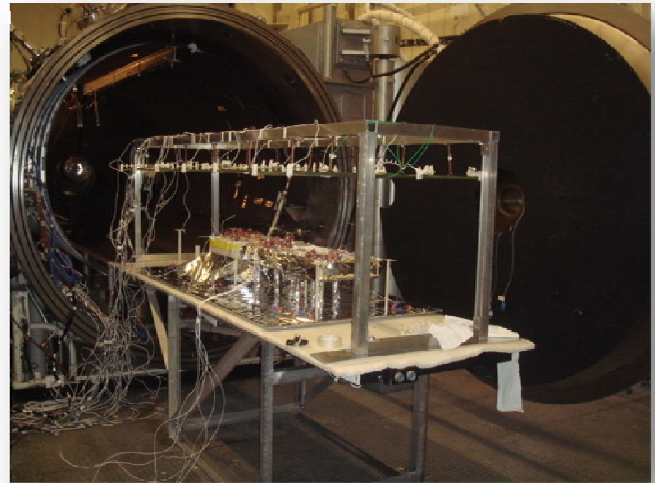

Rover Engineering Development Unit
Thermal Vacuum Evaluation – Chamber E

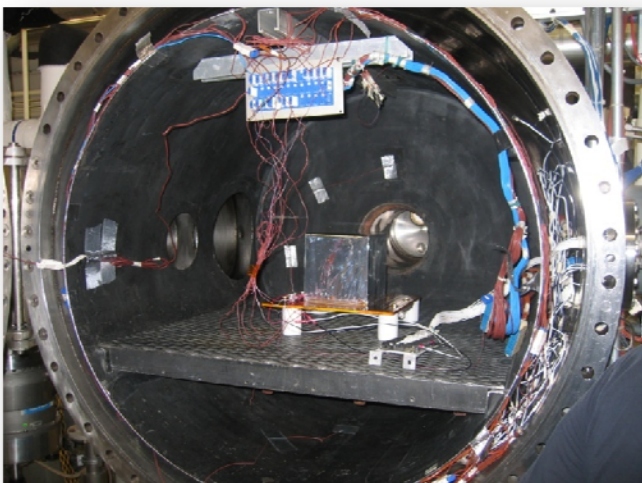

Thermal Stability Mapping Evaluation –
Chamber N

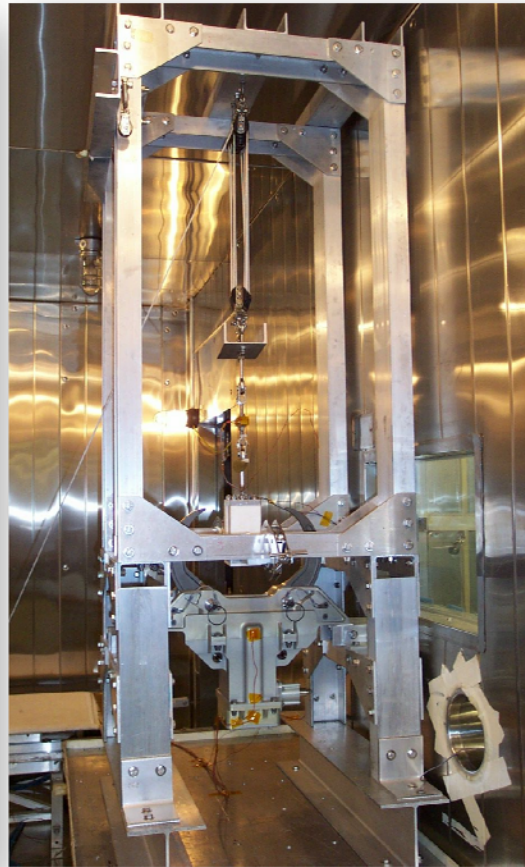

External Stowage Platform Attachment Device – Chamber H

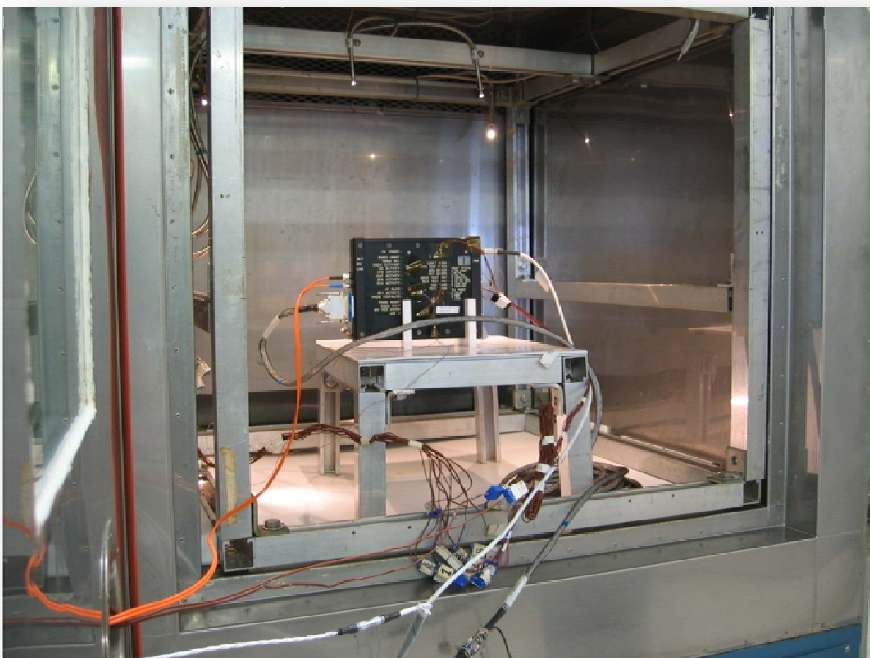

Orbiter Communication Adapter Universal Serial Bus – Chamber K

Appendix B Test Request Worksheet

Test Requester Information

Test Article Expert:	Contact Information (Phone, E-mail, Address):
----------------------	---

Test Objectives

Purpose of Test:	
Proposed Test Start Date:	Critical Test Start Date:

Test Article

Test Article Description:	
Physical Dimensions (L/W/H):	Weight:

Test Article Handling Requirements

Cleanliness Level:	Controlled Access:
Special Moving/Handling:	

Test Article Interface

Support Structure/Interface Points:	Orientation (fixed or moveable):
Mechanical Interface (fluids, operating pressure, flow, ventilation):	

Test Article Power Requirements (test article, support equipment, requester provided instrumentation):

Test Environment

Complete the Test Environment table below or provide a plot of the test environment to be simulated.

Type	Minimum	Maximum	Ramp Rate	Tolerance	No. of Cycles
Pressure					
Temperature					

Termination Criteria:

Hardware Functional (number, duration, description of functional to be performed):

Instrumentation

Instrumentation Provided by Test Requester:

List the primary measurements to be made (temperature, pressure, time):

Data Acquisition and Recording

Number of Channels:	Audio/Video Recording (Yes/No):
Sampling Rates:	Photographic Film (Yes/No):
Real-Time Data Processing (Yes/No):	High Speed/Low Speed:

Data Handling Requirements (storage, delivery, format):

Other Information

List any other information pertinent to the test:

Test Article Hazard Checklist

A hazard analysis statement is required for any of the following applicable attributes of any of your provided hardware (test article, support equipment).

Hazard	Y	N	Comments
Mechanical			
Handling (> 40 lb or > 4 ft, any dimension)			
Instability			
Sharp Edges			
Pinch Points			
Exposed Mechanisms (rotating, reciprocating)			
Pressure Systems			
Stored Energy (springs, weights, flywheels)			
Ejected parts, projectiles			
Electrical			
Voltage (> 50 volts)			
Batteries			
Generation/Storage (coils, magnets, capacitors)			
Electrostatic Sensitive Devices			

Hazard	Y	N	Comments
Thermal			
Hot Surfaces (> 113 °F, 45 °C)			
Heaters			
Cold Surfaces (< 39 °F, 4 °C)			
Cooling Devices			
Radiation			
Ionizing			
Non-Ionizing			
Laser			
Microwave			
Infrared (IR)			
Ultraviolet (UV)			
Radio Frequency (RF)			
Visible Light, High Intensity			
Material			
Uncontained Brittle Materials			
Test Environment Incompatibility			
Contained Fluids			
Toxic, Corrosive, Flammable Fluids			
Biohazards			
Miscellaneous			
Noise Level (> 85 dBA)			
Ultrasonic			
Pyrotechnics/Explosives			

Appendix C Example Test Request Worksheet

Test Requester Information

Test Article Expert: [Identify Test Article Expert]	Contact Information (Phone, E-mail, Address): [Test Article Expert Contact Information]
--	--

Test Objectives

Purpose of Test: Provide stated primary and secondary objectives. Wherever possible, specific goals and/or limitations should be included. The primary objectives are to be interpreted as minimum achievements for test success, and the secondary objectives are considered highly desirable options. <i>The objective of this test is to evaluate the performance of TA-1 during exposure to vacuum and a thermal environment ranging from -140 ± 4 °F to 160 ± 4 °F, with hardware functionals at ambient temperature, -35 ± 4 °F, -75 ± 4 °F, -140 ± 4 °F and 160 ± 4 °F. A total of 3 thermal cycles are required. One hour soaks should occur at -140 °F, $+160$ °F. Critical temperatures for TA-1 are $+190$ °F, -160 °F.</i>	
Proposed Test Start Date: <i>Proposed Start Date</i>	Critical Test Start Date: <i>Need Date</i>

Test Article

Test Article Description: Technical description of the test article, defining method of operation and theoretical considerations, referring to drawings and/or schematics if necessary. Operational characteristics, including normal and off-limit performance parameters, such as temperature, voltage, current, and flow rate. Operational constraints of the test article that cannot be violated without harming the test article (for example, pressure limits, environmental temperature limits, system cleanliness, and fluid purity).	
Physical Dimensions (L/W/H): <i>X" in length and X" in diameter</i>	Weight: <i>X mg</i>

Test Article Handling Requirements

<p>Cleanliness Level: <i>Generally clean</i></p>	<p>Controlled Access: <i>Secured overnight</i></p>
<p>Special Moving/Handling: <i>Test Requester will transport TA-1 directly to the test facility and remove from facility at completion of the test.</i></p>	

Test Article Interface

<p>Support Structure/Interface Points: <i>Mount TA-1 vertically to provide the antenna a view outside of chamber.</i></p>	<p>Orientation (fixed or moveable): <i>Fixed</i></p>
<p>Mechanical Interface (fluids, operating pressure, flow, ventilation): <i>Drawings attached:</i> <i>TA-1 Assembly</i> <i>TA-1 TC locations</i></p>	
<p>Test Article Power Requirements (test article, support equipment, requester-provided instrumentation): <i>120 Vdc for test article; 120 Vac for provided instrumentation (network analyzer, noise figure meter, noise source, digital multimeter, laptop computer, and docking station)</i></p>	

Test Environment

Complete the Test Environment table below or provide a plot of the test environment to be simulated.

Type	Minimum	Maximum	Ramp Rate	Tolerance	No. of Cycles
Pressure	1×10^{-4}		N/A	$\pm 25\%$	3
Temperature	$-135 \text{ }^\circ\text{F}$	$160 \text{ }^\circ\text{F}$	$2 \text{ }^\circ\text{F/minute}$	$\pm 4 \text{ F}$	3
Termination Criteria: <i>Critical temperatures for TA-1 are +190 °F, -160 °F.</i>					
Hardware Functional (number, duration, description of functional to be performed): <i>Hardware functional to be performed per the attached thermal profile. Duration of hardware functionals is ~ 1 hour per functional</i>					

Sample Thermal Profile with Functionals

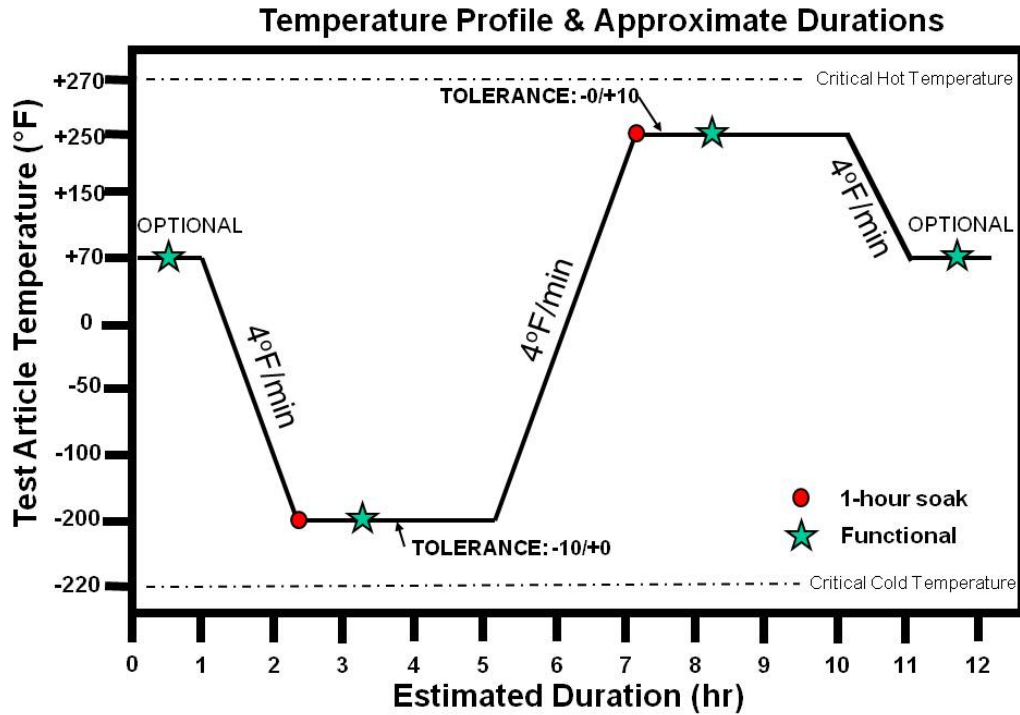

Instrumentation

Instrumentation Provided by Test Requester:

Identify requirements for instrumentation, data recording, displays, and data processing.

Power Supply – 120 Vdc

Network Analyzer

Noise Figure Meter

Noise Source

Digital Multimeter

Laptop Computer and Docking Station

List the primary measurements to be made (temperature, pressure, time):

Temperature of TA-1 – 14 TC's (See attached drawing for TC locations)

Atmospheric Pressure

Data Acquisition and Recording

Number of Channels: <i>14</i>	Audio/Video Recording (Yes/No): <i>No</i>
Sampling Rates: <i>1 sample/minute</i>	Photographic Film (Yes/No): <i>Yes</i>
Real-Time Data Processing (Yes/No): <i>No</i>	High Speed/Low Speed: <i>N/A</i>
Data Handling Requirements (storage, delivery, format): DVD (Excel File)	

Other Information

List any other information pertinent to the test:

Test Article Hazard Checklist

A hazard analysis statement is required for any of the following applicable attributes of any of your provided hardware (test article, support equipment)

Hazard	Y	N	Comments
Mechanical			<i>Identify the hazards and present the approach for mitigating each</i>
Handling (> 40 lb or > 4 ft, any dimension)			
Instability			
Sharp Edges			
Pinch Points			
Exposed Mechanisms (rotating, reciprocating)			
Pressure Systems			
Stored Energy (springs, weights, flywheels)			
Ejected Parts, Projectiles			
Electrical			
Voltage (> 50 volts)			<i>TA-1 power supply 120 Vdc</i>
Batteries			
Generation/Storage (coils, magnets, capacitors)			
Electrostatic Sensitive Devices			

Hazard	Y	N	Comments
Thermal			<i>Identify the hazards and present the approach for mitigating each</i>
Hot Surfaces (> 113 °F, 45 °C)			
Heaters			
Cold Surfaces (< 39 °F, 4 °C)			
Cooling Devices			
Radiation			
Ionizing			
Non-Ionizing			
Laser			
Microwave			
Infrared (IR)			
Ultraviolet (UV)			
Radio Frequency (RF)			
Visible Light, High Intensity			
Material			
Uncontained Brittle Materials			
Test Environment Incompatibility			
Contained Fluids			
Toxic, Corrosive, Flammable Fluids			
Biohazards			
Miscellaneous			
Noise Level (> 85 dBA)			
Ultrasonic			
Pyrotechnics/Explosives			

Appendix D Instrumentation Provided by Facility

Data is typically recorded at one sample-per-second, but higher rates can be achieved if desired. The following tables list instrumentation capabilities that are commonly available. We can accommodate different ranges or types of instrumentation as required by the Test Requester. Contact the Test Director to discuss data/instrumentation requirements.

Facility	Temperature Range	Pressure Range
Chamber E	* – -280 °F	10e ⁻⁵ – 760 torr
Chamber N	* – -280 °F	10e ⁻⁵ – 760 torr
Chamber P	Ambient – 350 °F	10e ⁻⁵ – 760 torr
Chamber K	-160 – 350 °F	N/A
Chamber T	-200 – 275 °F	N/A
Chamber H	-150 – 200 °F	N/A

* IR Lamps can be used to increase the temperature of the test article

Temperature is recorded in degrees Fahrenheit and the chambers are equipped with type T thermocouples.

Instrumentation	Range
Absolute Pressure	Ambient – 320 PSIA ± 0.5% Full Scale (FS)
Differential Pressure	0 – 300 PSID ± 0.5% FS
Flow	As low as 10 SCFM ± 1% FS

We can accommodate a wide range of pressure and flow parameters. We can also accommodate current and voltage measurements.

Appendix E Customer Feedback

TEST CUSTOMER FEEDBACK									
Test Title:				Facility:					
Test Number:		TD:		Test Date:					
SCHEDULE:				SCORE (Check or Click on Box)					
				Poor		Excellent			
				1	2	3	4	5	N/A
1. Was the test initiated and completed to meet your requirements?				<input type="checkbox"/>	<input type="checkbox"/>	<input type="checkbox"/>	<input type="checkbox"/>	<input type="checkbox"/>	<input type="checkbox"/>
2. Were we able to accommodate your requested schedule changes?				<input type="checkbox"/>	<input type="checkbox"/>	<input type="checkbox"/>	<input type="checkbox"/>	<input type="checkbox"/>	<input type="checkbox"/>
COST:									
3. Was the test performed within estimated budget?				<input type="checkbox"/>	<input type="checkbox"/>	<input type="checkbox"/>	<input type="checkbox"/>	<input type="checkbox"/>	<input type="checkbox"/>
4. Was the test cost reasonable for the test performed?				<input type="checkbox"/>	<input type="checkbox"/>	<input type="checkbox"/>	<input type="checkbox"/>	<input type="checkbox"/>	<input type="checkbox"/>
PRODUCT:									
5. Was the provided test data accurate?				<input type="checkbox"/>	<input type="checkbox"/>	<input type="checkbox"/>	<input type="checkbox"/>	<input type="checkbox"/>	<input type="checkbox"/>
6. Was the test data provided to you in an acceptable format and a timely manner?				<input type="checkbox"/>	<input type="checkbox"/>	<input type="checkbox"/>	<input type="checkbox"/>	<input type="checkbox"/>	<input type="checkbox"/>
FACILITY (Test Position and Support Hardware):									
7. Did the facility's capability meet the needs of the test requirements?				<input type="checkbox"/>	<input type="checkbox"/>	<input type="checkbox"/>	<input type="checkbox"/>	<input type="checkbox"/>	<input type="checkbox"/>
8. Was the facility reliable during the test?				<input type="checkbox"/>	<input type="checkbox"/>	<input type="checkbox"/>	<input type="checkbox"/>	<input type="checkbox"/>	<input type="checkbox"/>
TEST TEAM:									
9. Did you find the test team helpful and knowledgeable in meeting your objective?				<input type="checkbox"/>	<input type="checkbox"/>	<input type="checkbox"/>	<input type="checkbox"/>	<input type="checkbox"/>	<input type="checkbox"/>
10. Would you consider using this test facility for future tests?				<input type="checkbox"/>	<input type="checkbox"/>	<input type="checkbox"/>	<input type="checkbox"/>	<input type="checkbox"/>	<input type="checkbox"/>
Note: We are concerned and interested in your comments and would like an opportunity to improve our service									
Comments/Suggestions for Improvement:									
Customer Name & Organization:									
Return to: Michael Montz, michael.e.montz@nasa.gov									