

## CHARACTERIZATION OF A COMMON-GATE AMPLIFIER USING FERROELECTRIC TRANSISTORS

Mitchell Hunt<sup>1</sup>, Rana Sayyah<sup>1</sup>, Todd C. MacLeod<sup>2</sup>, and Fat D. Ho<sup>1</sup>

<sup>1</sup>The University of Alabama in Huntsville, Department of Electrical and Computer Engineering, Huntsville, Alabama, 35899, USA

<sup>2</sup>National Aeronautics and Space Administration, Marshall Space Flight Center, Huntsville, Alabama, 35812, USA

### ABSTRACT

In this paper, the empirical data collected through experiments performed using a FeFET in the common-gate amplifier circuit is presented. The FeFET common-gate amplifier was characterized by varying all parameters in the circuit, such as load resistance, biasing of the transistor, and input voltages. Due to the polarization of the ferroelectric layer, the particular behavior of the FeFET common-gate amplifier presents interesting results. Furthermore, the differences between a FeFET common-gate amplifier and a MOSFET common-gate amplifier are examined.

**Keywords:** FeFET; FFET; ferroelectric transistor; common-gate amplifier



Mitchell Hunt University of Alabama in Huntsville, Rana Sayyah University of Alabama in Huntsville, Todd C. MacLeod NASA Marshall Space Flight Center, Fat D. Ho University of Alabama in Huntsville

## Abstract:

Tests were performed with the ferroelectric transistor (FeFET) in the common-gate amplifier circuit shown in Figure 1, and empirical data was collected including the output voltage, phase shift, and voltage gain of the amplifier. This data, which shows considerable attenuation at high frequencies and low-frequency gain of over 6 dB, is presented to characterize the frequency response of the amplifier circuit when an FeFET is added. Additionally, the quiescent point for a given polarization of the FeFET is shown to have influence over both the cutoff frequency and the phase shift. Similarly, large load resistances are shown to decrease the gain and phase shift of the amplifier. The variations in phase shift, gain, and cutoff frequency reflect aspects of the FeFET performance in the common-gate amplifier circuit that are not seen with the MOSFET.

## Introduction:

The ferroelectric transistor (FeFET) has a layer of ferroelectric material, which is composed of PZT, between the oxide and channel of the transistor. Although FeFET's are well known devices, their performance in various analog circuits has not yet been characterized. The FeFET's two states, which are induced by either positive or negative poling voltages, allow for vastly different operation within a single circuit by only applying a different poling voltage and biasing conditions. These particular aspects of the FeFET operation showcase deviations from the MOSFET performance.

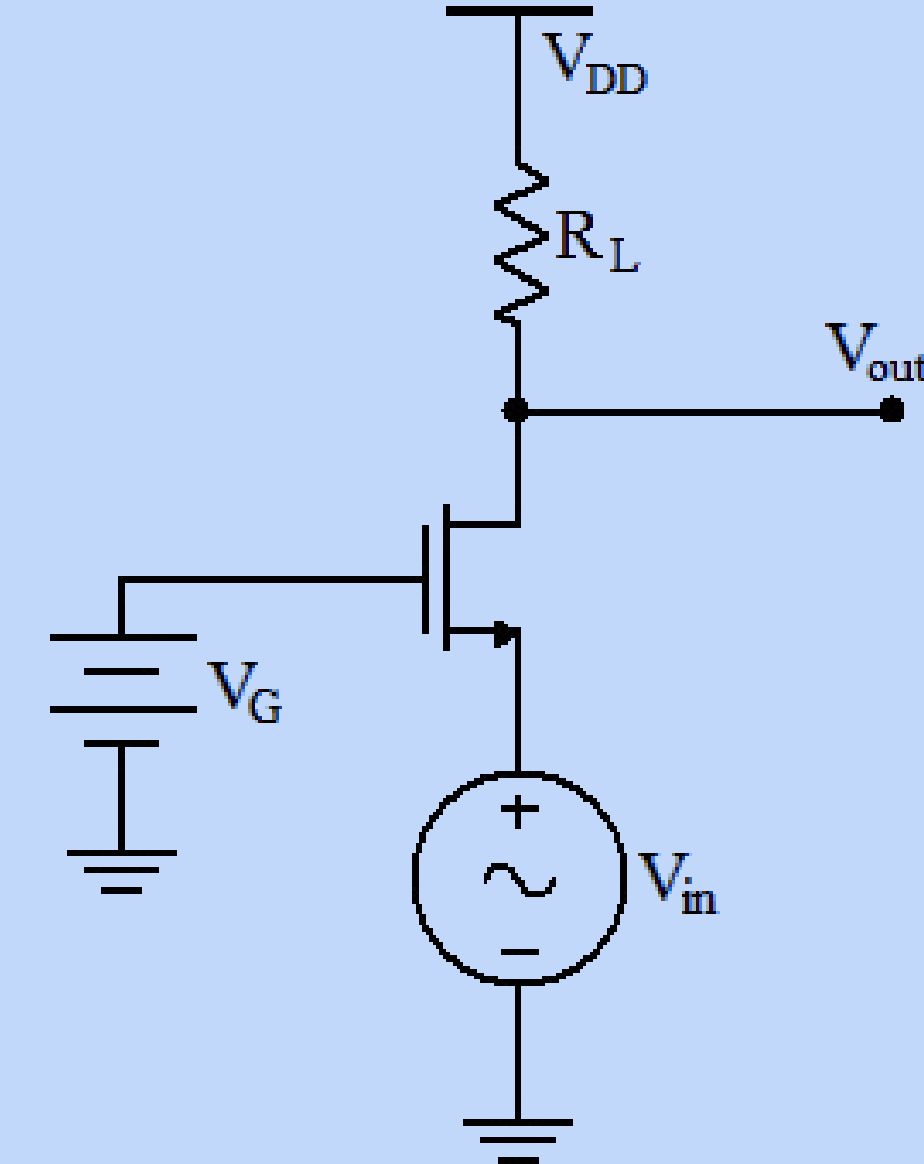

Figure 1: FeFET Common-Gate Amplifier

## Testing:

All tests were performed for both positive and negative poling voltages, including varying load resistance and input frequency, amplitude, and waveform type. Measurements taken during each test consisted of the output voltage, phase shift relative to the input voltage, and the overall gain of the amplifier was calculated.

To examine the frequency response of the common-gate amplifier, the input frequency was varied from 1 Hz up to 2.3 MHz, with 9 intermediate frequencies, and data was collected at each of these frequencies.

With both the positive and negative poling voltages, the effects of varying the biasing conditions on the FeFET were also observed. This was accomplished by changing  $V_G$  for a given value of  $V_{DD}$ . However, the power supply  $V_{DD}$  was also adjusted to allow for large voltage swings at the drain of the transistor.

The linearity of gain was examined by changing the input signal to a triangle wave from a sine wave. In this fashion the linearity of the gain is directly shown by comparing the two signals.

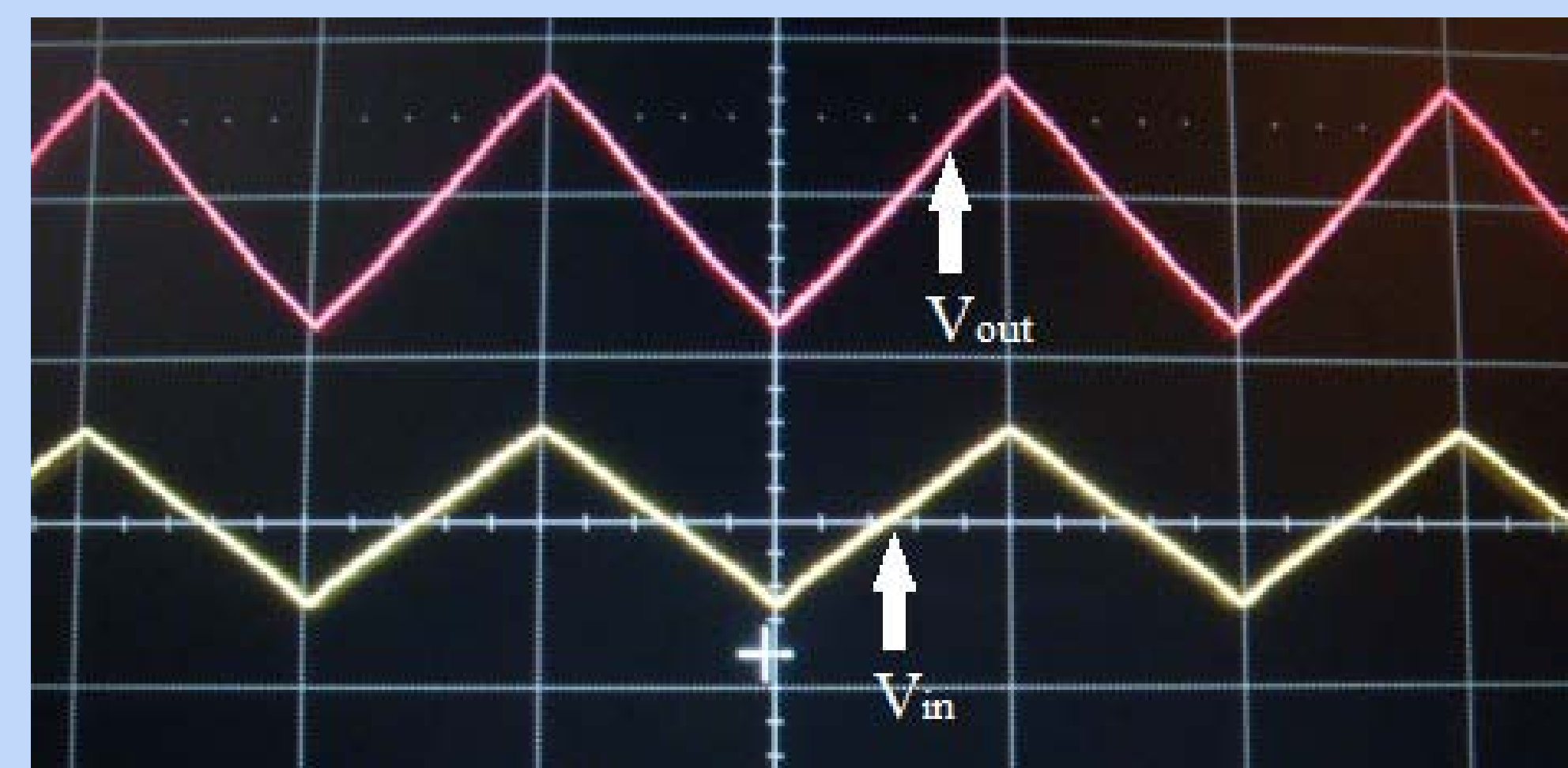

$V_{in} = 1V_{pp}$   $V_G = 4V$   
 $V_{DD} = 4V$  Frequency = 1kHz

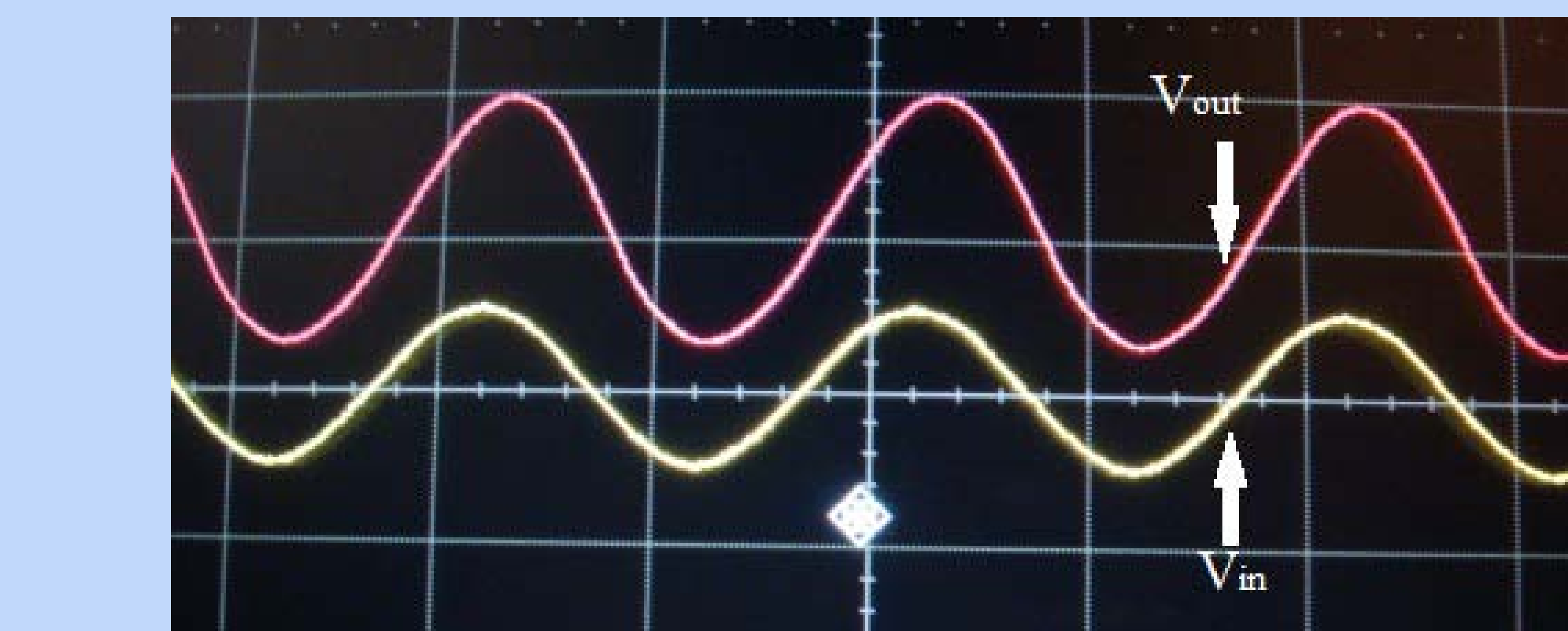

$V_{in} = 1V_{pp}$   $V_G = -1V$   $V_{out}^+ = 2.69V$   $\Phi = 16^\circ$   
Frequency = 50kHz  $V_{DD} = 4V$   $V_{out}^- = 0.725V$

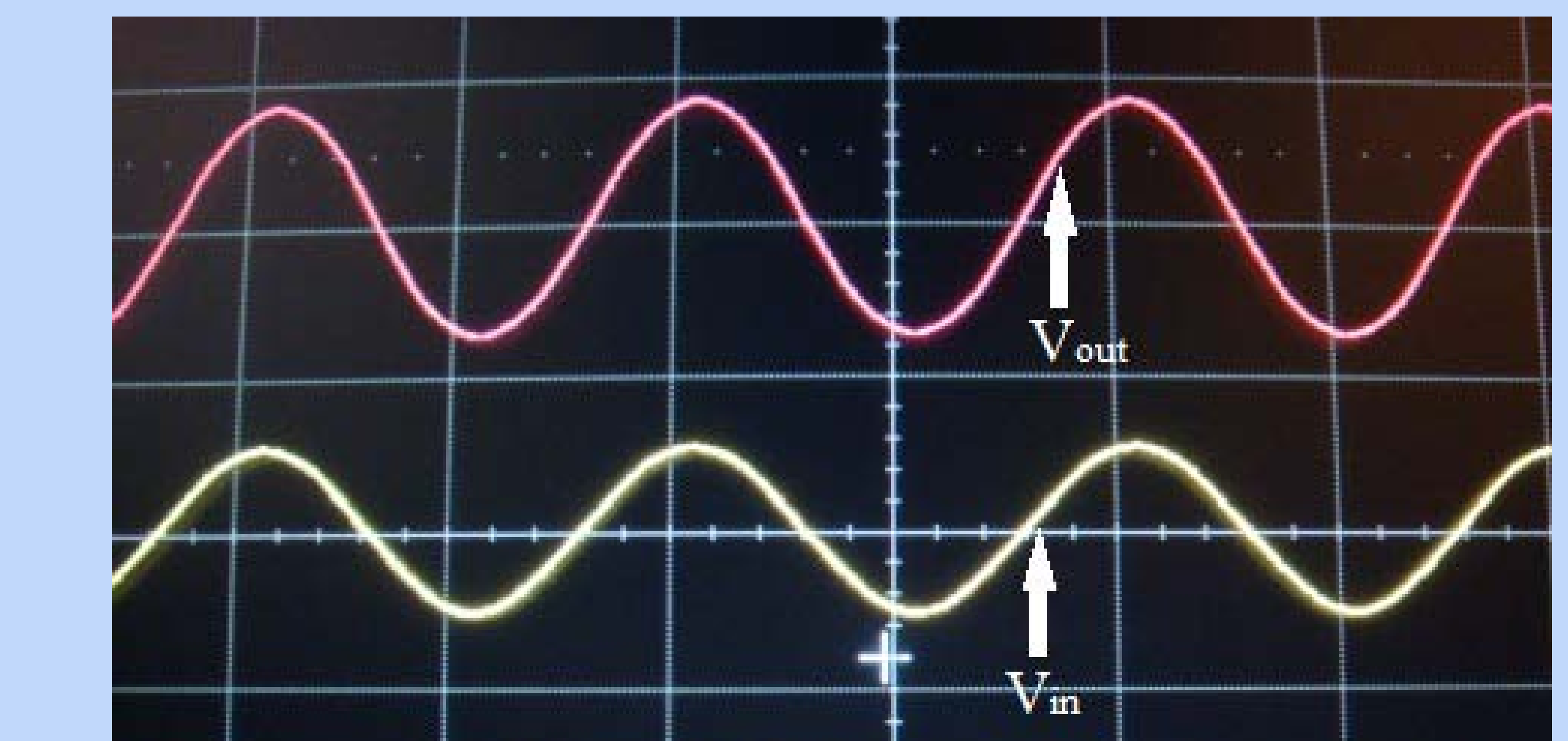

$V_{in} = 1V_{pp}$   $V_G = 4V$   $V_{out}^+ = 2.705V$   $\Phi = 3^\circ$   
Frequency = 1kHz  $V_{DD} = 4V$   $V_{out}^- = 1.136V$

## Results:

The voltage gain of the common-gate amplifier was similar for both positive and negative poling voltages. Typically, the low-frequency gain of the amplifier was 5 – 7 dB. However, the cutoff frequency tended to be lower with a negative poling voltage, falling between 85 kHz and 115 kHz. For positive poling voltages, the cutoff frequency occurred between 100 kHz and 130 kHz. The low-frequency phase shift observed at the output was significantly modulated by the biasing voltage  $V_G$ . While at lower frequencies, the phase shift fell between  $-10^\circ$  and  $10^\circ$ . The phase shift peaked at approximately  $85^\circ$  for frequencies between 500 kHz – 2.3 MHz, again depending on the biasing voltage  $V_G$ . However, at very high frequencies of 2.3 MHz, the phase shift tended to decrease to about  $75^\circ$  depending on the biasing voltage used.

By increasing the load resistance beyond 10 k $\Omega$ , the voltage gain dropped sharply. Interestingly, the plot of voltage gain for varying load resistance given positive and negative poling voltages closely overlap for  $R_L$  greater than 20 k $\Omega$ . Much like voltage gain, the phase shift also decreased for both small and large loads and peaked at 10 k $\Omega$ .

When a triangle wave was input to the amplifier circuit, the output was an almost exactly scaled representation of the output, displaying the great linearity of the gain.

## Conclusion:

By using an FeFET in the common-gate amplifier circuit, the circuit is able to operate for both negative and zero biasing voltages applied to the gate. Furthermore, with a negative poling voltage the maximum gain of 6.68 dB was obtained while using a negative biasing voltage of -1 V. At very high frequencies of 2.3 MHz, the phase shift decreased in several tests, falling from its peak value to as low as  $70^\circ$  for some biasing voltages. Also, the low frequency phase shift value depended on both the biasing level and polarity of the poling voltage, with positive poling voltages generally being more negative. The many interesting properties of the FeFET allow for very different operation in the common-gate amplifier circuit by using a different poling voltage or biasing the transistor differently, and these effects are not typically seen when using a MOSFET.

## References:

1. M. Hunt, R. Sayyah, T. C. MacLeod, F. D. Ho. Characterization of a Common-Source Amplifier using Ferroelectric Transistors. Integrated Ferroelectrics. 2010.
2. T. C. MacLeod, T. A. Phillips, F. D. Ho. Characterizing an analog amplifier utilizing a ferroelectric transistor. Integrated Ferroelectrics. 2008. 104: 40-47.
3. T. C. MacLeod, F. D. Ho. I-V Characteristics of a ferroelectric field effect transistor. Integrated Ferroelectrics. 2001. 34: 21-26.
4. R. Sayyah, M. Hunt, T. C. MacLeod, F. D. Ho. An empirical study of a FeFET-based analog amplifier. Integrated Ferroelectrics. 2009. 107: 31-42.

