

mixed with spray paint. The magnetic material should be one of high retentivity and high coercivity. The matrix symbol pattern can be defined by use of a stencil, or recesses to hold the magnetic material in the matrix symbol pattern can be formed by laser engraving, machine engraving, micro-abrasive blasting, laser etching, or any other suitable marking method. If the magnetic material as applied is not magnetized strongly enough to enable reliable detection over time, it can be magnetized again by use of a permanent magnet or electromagnet.

Bar codes were seldom seen before 1975 but are now common in every commercial outlet. They are on tags and labels of virtually every product. Likewise, direct part marking is now being popularized for tracking things that cannot be labeled. NASA tracks parts using direct part marking. The Department of Defense revised MIL STD 130 to include matrix symbols for direct part marking, and the automotive industry now complies with its B-17 specification for application of matrix symbols on many automobile parts. Now all those little marks that get covered with paint, whether they are on your auto-

mobile, jet fighter, weapon, or space shuttle, can be read with ease.

*This work was done by Harry F. Schramm and Clyde S. Jones of Marshall Space Flight Center; Donald L. Roxby and James D. Teed of Rockwell International Corp.; and William C. L. Shih, Gerald L. Fitzpatrick, and Craig Knisely of PRI Research and Development Corp.*

*This invention is owned by NASA, and a patent application has been filed. For further information, contact Sammy Nabors, MSFC Commercialization Assistance Lead, at [sammy.a.nabors@nasa.gov](mailto:sammy.a.nabors@nasa.gov). Refer to MFS-31013/768.*

## System for Processing Coded OFDM Under Doppler and Fading

### Advanced techniques would help to realize the anti-fading potential of OFDM.

NASA's Jet Propulsion Laboratory, Pasadena, California

An advanced communication system has been proposed for transmitting and receiving coded digital data conveyed as a form of quadrature amplitude modulation (QAM) on orthogonal frequency-division multiplexing (OFDM) signals in the presence of such adverse propagation-channel effects as large dynamic Doppler shifts and frequency-selective multipath fading. Such adverse channel effects are typical of data communications between mobile units or between mobile and stationary units (e.g., telemetric transmissions from aircraft to ground stations). The proposed system incorporates novel signal processing techniques intended to reduce the losses associated with adverse channel effects while maintaining compatibility with the high-speed physical layer specifications defined for wireless local-area networks (LANs) as the standard

802.11a of the Institute of Electrical and Electronics Engineers (IEEE 802.11a).

OFDM is a multi-carrier modulation technique that is widely used for wireless transmission of data in LANs and in metropolitan area networks (MANs). OFDM has been adopted in IEEE 802.11a and some other industry standards because it affords robust performance under frequency-selective fading. However, its intrinsic frequency-diversity feature is highly sensitive to synchronization errors; this sensitivity poses a challenge to preserve coherence between the component subcarriers of an OFDM system in order to avoid intercarrier interference in the presence of large dynamic Doppler shifts as well as frequency-selective fading. As a result, heretofore, the use of OFDM has been limited primarily to applications involving small or zero

Doppler shifts. The proposed system includes a digital coherent OFDM communication system that would utilize enhanced 802.11a-compatible signal-processing algorithms to overcome effects of frequency-selective fading and large dynamic Doppler shifts. The overall transceiver design would implement a two-frequency-channel architecture (see figure) that would afford frequency diversity for reducing the adverse effects of multipath fading. By using parallel concatenated convolutional codes (also known as Turbo codes) across the dual-channel and advanced OFDM signal processing within each channel, the proposed system is intended to achieve at least an order of magnitude improvement in received signal-to-noise ratio under adverse channel effects while preserving spectral efficiency.

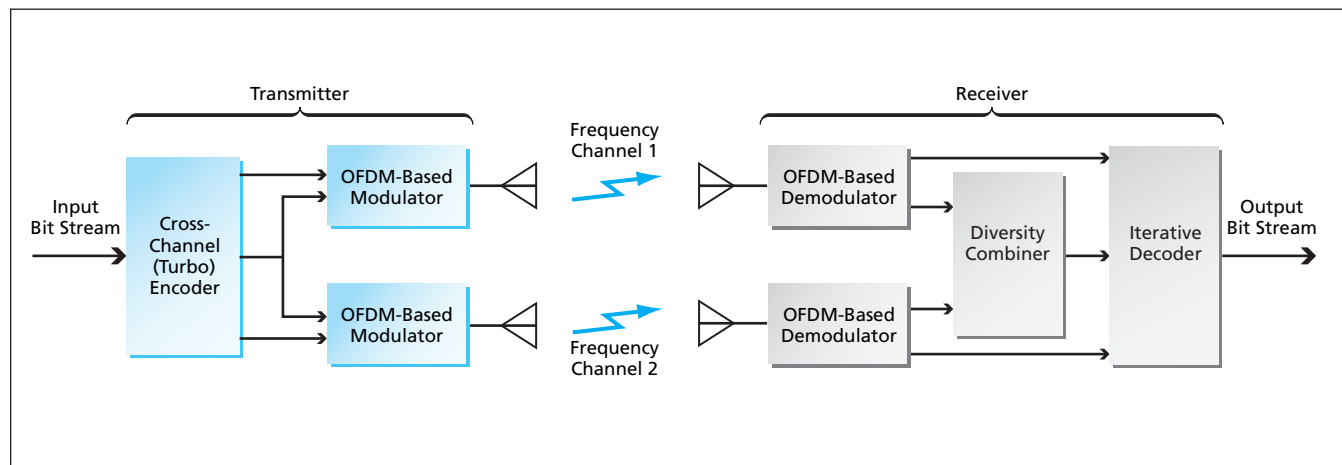

A Two-Frequency-Channel, Cross-Coded OFDM System would contain the proposed signal-processing system, parts of which would reside in both transmitting and receiving subsystems.

One of the novel techniques adopted for the proposed system would be multipass processing of packet preamble for acquisition of frequencies and timing of carrier and data symbols. The multipass approach is intended to eliminate as much synchronization error as possible at an early stage of packet preamble processing in order to reduce the inter-carrier interference, which can contribute significantly to the bit-error rate under adverse channel conditions.

Another novel signal-processing technique would be joint pilot- and data-aided

channel estimation, tracking, and equalization in each of the two frequency channels. This technique would not only increase the accuracy in the estimate of the channel effects, but also would support tracking of dynamic Doppler shifts, resulting in a much improved channel equalization under adverse channel conditions.

Another novel aspect of the design would be the use of (1) turbo cross-channel coding in the transmitter in conjunction with (2) diversity combining of signals in the receiver. The gain afforded by this combination of coding and fre-

quency and time diversity would help to counteract severe fading, especially for the case when both channels are simultaneously affected by deep fades.

*This work was done by Haiping Tsou, Scott Darden, Dennis Lee, and Tsun-Yee Yan of Caltech for NASA's Jet Propulsion Laboratory. Further information is contained in a TSP (see page 1)*

*The software used in this innovation is available for commercial licensing. Please contact Karina Edmonds of the California Institute of Technology at (818) 393-2827. Refer to NPO-40205.*

## Multipurpose Hyperspectral Imaging System

Features include high spectral and spatial resolution, without camera/target relative motion.

*Marshall Space Flight Center, Alabama*

A hyperspectral imaging system of high spectral and spatial resolution that incorporates several innovative features has been developed to incorporate a focal-plane scanner (U.S. Patent 6,166,373). This feature enables the system to be used for both airborne/spaceborne and laboratory hyperspectral imaging with or without relative movement of the imaging system, and it can be used to scan a target of any size as long as the target can be imaged at the focal plane; for example, automated inspection of food items and identification of single-celled organisms. The spectral resolution of this system is greater than that of prior terrestrial multispectral imaging systems. Moreover, unlike prior high-spectral-resolution airborne and spaceborne hyperspectral imaging systems, this system does not rely on relative movement of the target and the imaging system to sweep an imaging line across a scene.

This compact system (see figure) consists of a front objective mounted at a translation stage with a motorized actuator, and a line-slit imaging spectrograph mounted within a rotary assembly with a rear adaptor to a charged-coupled-device (CCD) camera. Push-broom scanning is carried out by the motorized actuator which can be controlled either manually by an operator or automatically by a computer to drive the line-slit across an image at a focal plane of the front objective. To reduce the cost, the system has been designed to integrate as many as possible off-the-shelf components including the CCD camera and spectrograph. The system has achieved high spectral and spatial resolutions by using a high-quality CCD camera, spectrograph, and front objective lens. Fixtures

for attachment of the system to a microscope (U.S. Patent 6,495,818 B1) make it possible to acquire multispectral images of single cells and other microscopic objects.

To make it unnecessary to move the camera relative to the target or vice versa, the design of the system provides for lateral motion of the image on the focal plane. For this purpose, the front lens is mounted on a translational stage driven by a computer-controlled motor.

The system also includes a computer programmed with special-purpose operational software; frame-grabber, and motor-control circuit boards connected between

the computer on one hand and the CCD and motor, respectively, on the other hand; and light sources. The system can collect image data in as many as 1,040 spectral bands in the wavelength range from 400 to 1,000 nm.

The special-purpose operational software is a single computer program that controls all aspects of the acquisition and preprocessing of image data, performing functions that, heretofore, entailed the use of several different programs: The software controls the camera, scanning speed, and start and stop positions, and automatically drives the motorized actuator in push-

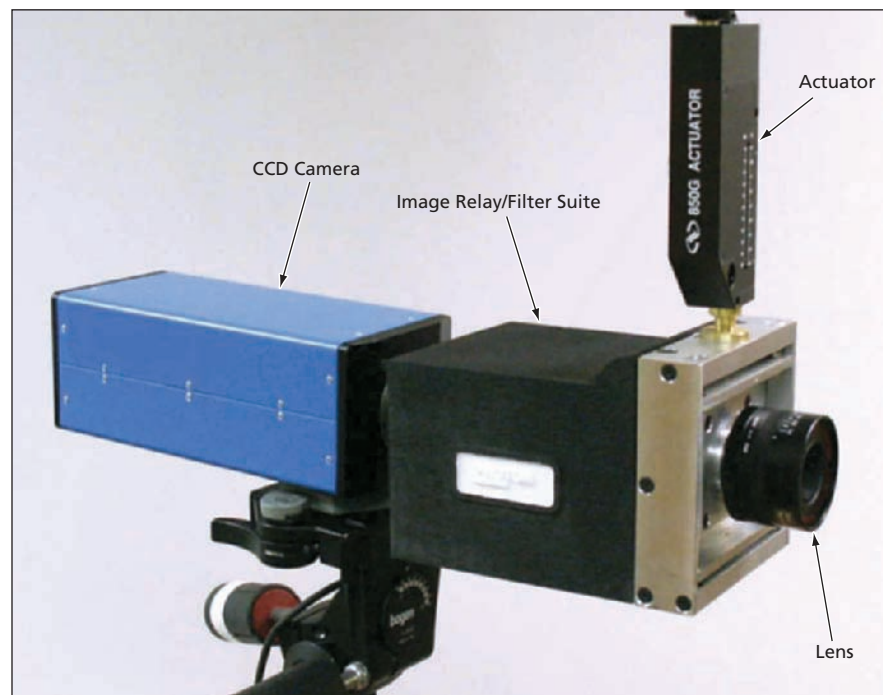

The Main Front Components of the imaging system are shown mounted on the tripod.