



Setting the Standard for Automation™

Utilizing Non-Contact Stress Measurement System (NSMS) as a Health Monitor

Terry Hayes, Bryan Hayes, Ken Bynum
Aerospace Testing Alliance (ATA)
Arnold Air Force Base, TN

Standards
Certification
Education & Training
Publishing
Conferences & Exhibits



Utilizing Non-Contact Stress Measurement System (NSMS) as a Health Monitor

Terry Hayes, Bryan Hayes, Ken Bynum
Aerospace Testing Alliance (ATA)
Arnold Air Force Base, TN

Approved for public release; distribution is unlimited.

57th International Instrumentation Symposium
2nd Tip Timing Workshop
St. Louis, Mo
20-22 June 2011

Air Force Materiel Command
Arnold Engineering Development Center
Arnold Air Force Base, TN 37389



ARNOLD ENGINEERING DEVELOPMENT CENTER

CONTRACTOR – AEROSPACE TESTING ALLIANCE

**Ground
Test
Facility**

Diverse Test Units

**Aircraft System,
Aeropropulsion,
and Space and
Missile Testing**

**Government
and
Commercial
customers**

**Continuously
Changing
test
objectives**

Approved for public release; distribution is unlimited.

NASA Ames 11 by 11 Foot Transonic Wind Tunnel



Approved for public release; distribution is unlimited.

NASA Ames 11 by 11 Foot Transonic Wind Tunnel Compressor

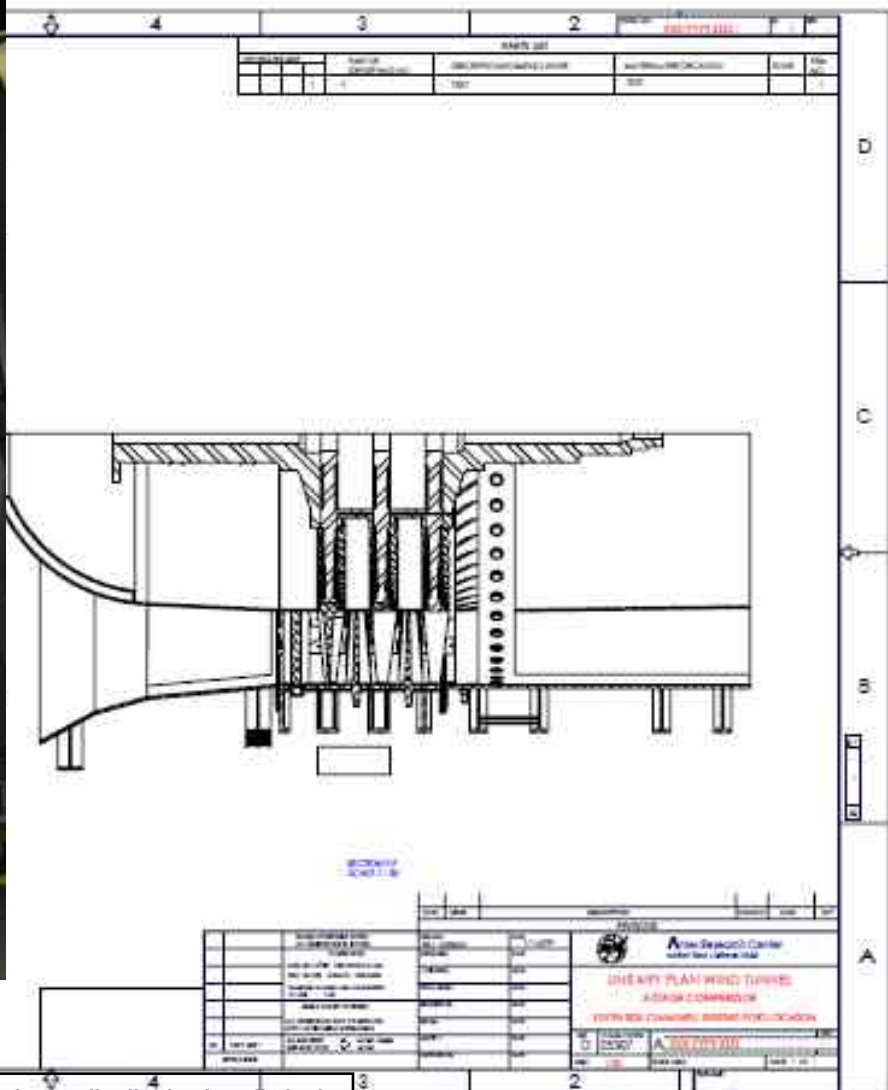
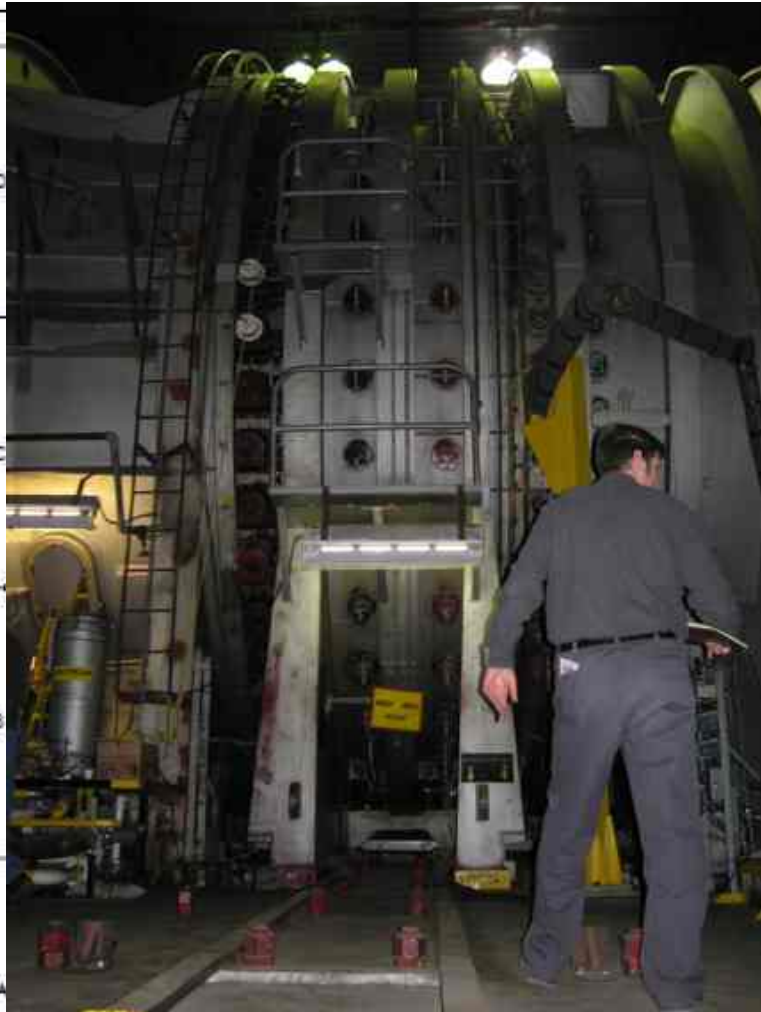

Approved for public release; distribution is unlimited.

*NASA Ames 11 by 11 Foot Transonic Wind Tunnel
Disc/Blade View*



Approved for public release; distribution is unlimited.



Unitary 11 Ft Transonic Wind Tunnel (TWT) Three-Stage Compressor Requirements



- Continuously monitor all 156 blades throughout the entire operating envelope without adversely affecting tunnel conditions or compromise compressor shell integrity.
- Calculate dynamic response and identify the frequency/mode to determine individual blade deflection amplitudes, natural frequencies, phase, and damping (Q).
- Log static deflection to build a database of deflection values at certain compressor conditions to use as basis for real-time online Blade Stack monitor
- Monitor for stall, surge, flutter, and blade damage (from foreign object (FOD) or domestic object (DOD) damage).
- Operate with limited user input, low maintenance cost, safe illumination of probes, easy probe replacement, and require little or no access to compressor (probe alignment technique from outside).

Unitary 11 Ft Transonic Wind Tunnel (TWT) Three-Stage Compressor Challenges



- Non-Uniform Blades
 - Blended over the years to extend life of blades
 - At least they are aluminum!
- Vibration modes to monitor
 - Higher order modes
 - Relatively close probe spacing
 - Simultaneous Modes
- Feasibility Study could only accommodate one probe per blade row
 - But still demonstrate mode identification
- Short Time window for probe design
 - Compressor available for drilling once every 3-4 years
 - Five months after feasibility study

Lessons learned applied from previous plant applications

NASA Ames 11 by 11 Foot Transonic Wind Tunnel Block Diagram – Feasibility Study

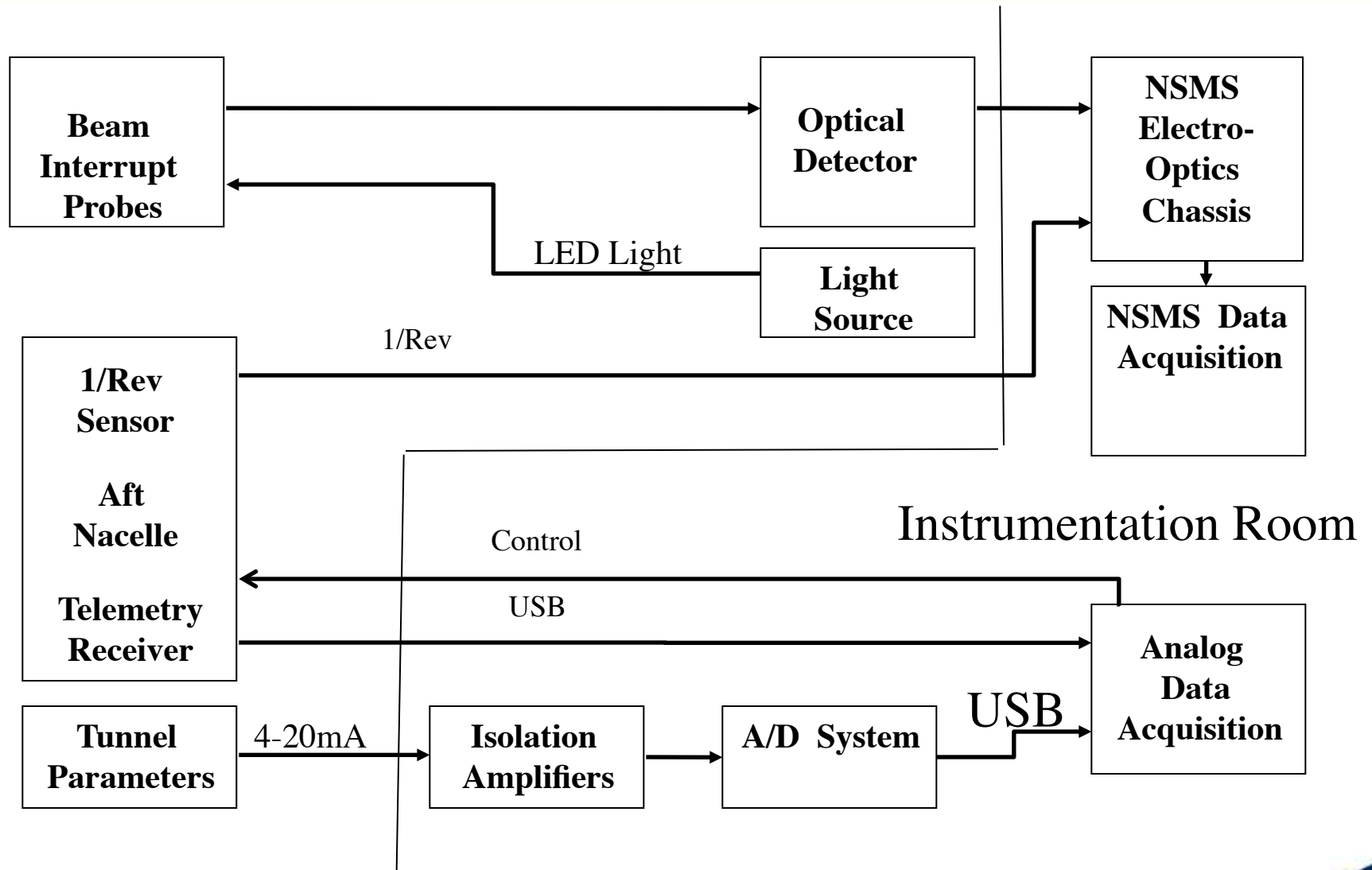

Approved for public release; distribution is unlimited.

NASA Ames 11 by 11 Foot Transonic Wind Tunnel Probe Design



- Custom designed probe by AEDC
- Utilizes collimating lens, 45 degree mirror, plastic window, and SMA barrel (for fiber coupling) installed in a custom grown (DMLS) housing made from stainless steel



NASA Ames 11 by 11 Foot Transonic Wind Tunnel Beam Interrupt Probe Installation



Utilized Inspection Ports to eliminate drilling for Feasibility Study



*NASA Ames 11 by 11 Foot Transonic Wind Tunnel
Beam Interrupt Probe*



Approved for public release; distribution is unlimited.

NASA Ames 11 by 11 Foot Transonic Wind Tunnel Sample Probe Data

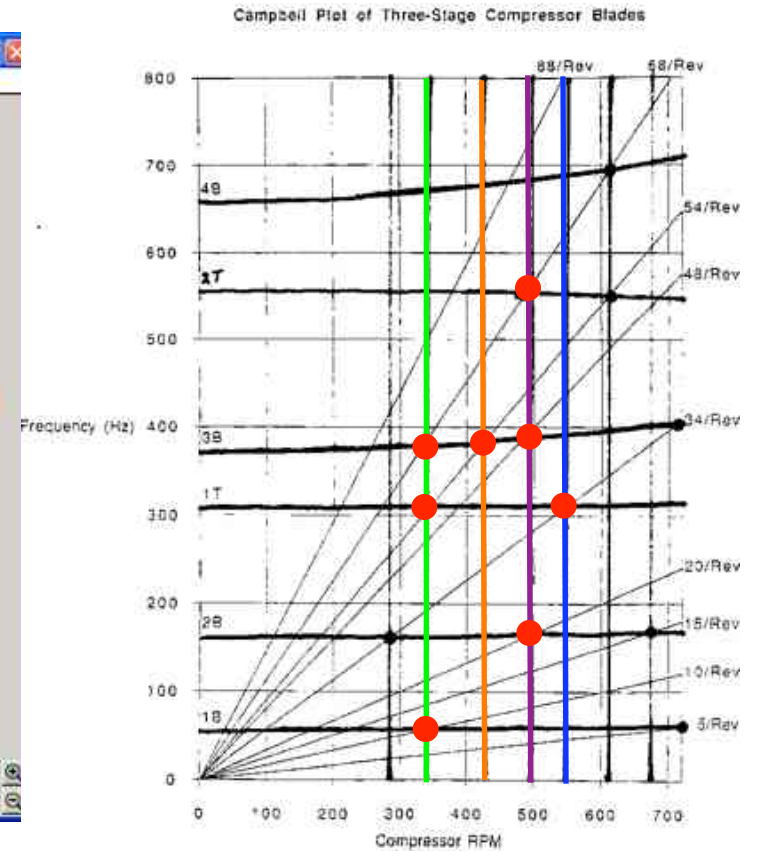
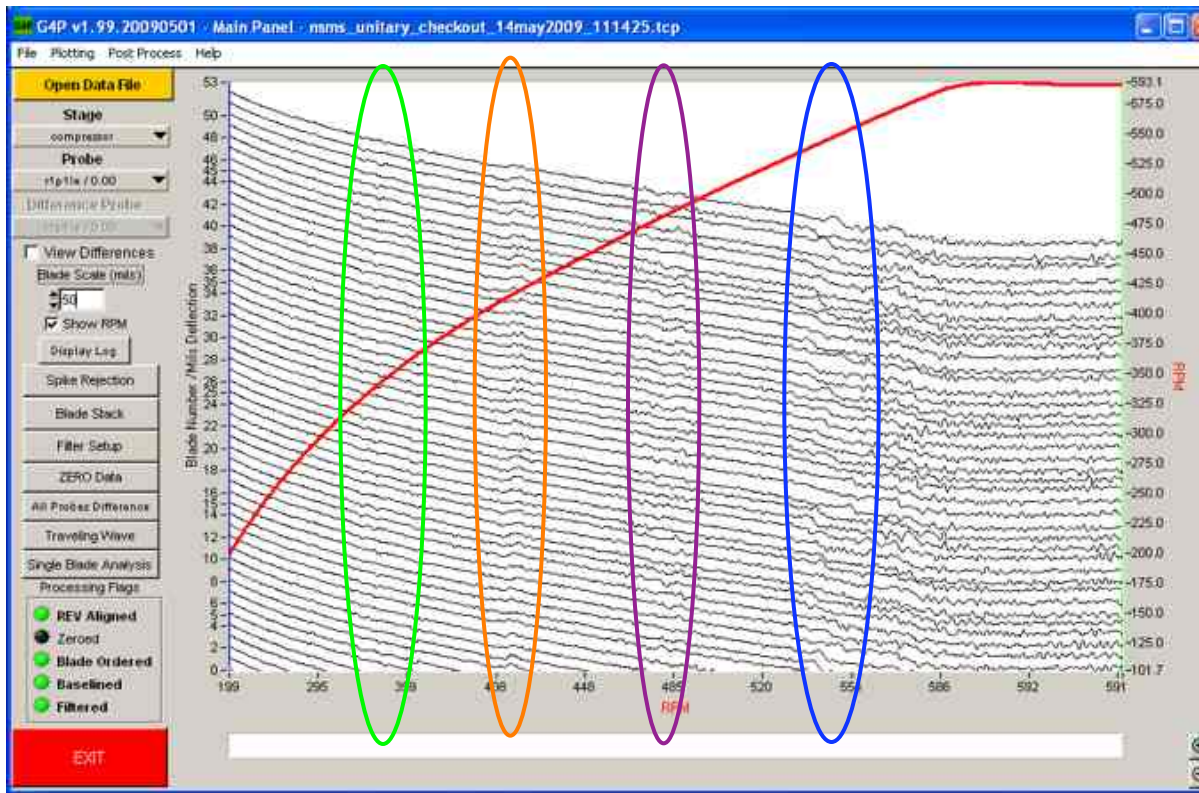

Ref: AIAA 95-3139
Nguyen, Guist, Muzzio

NASA Ames 11 by 11 Foot Transonic Wind Tunnel Feasibility Data Analysis



- 34E/1T on Stage 2 and 10E/1B on Stage 3 demonstrate quality NSMS data from a single probe
- 54E/3B on Stage 2 response is highly inconsistent and demonstrates the need for multiple probes for high quality NSMS data
- The recently acquired (but limited) NSMS data falls within the bounds of the historical strain gage data for frequency and damping for a single tone
 - Missing data for the following modes:
 - 68E/3B, 54E/1T, 68E/2T, 68E/3B, 20E/2B, 54E/2T, 68E/4B, 34E/3B, and 5E/1B due to lack of multiple NSMS probes and not covering the entire operating range of the compressor

NASA Ames 11 by 11 Foot Transonic Wind Tunnel Status



- ***Feasibility test successful***
- NSMS static data is very consistent for the
 - Blade stack
 - Loading deflection on the LE and TE
 - Blade Untwist
- NSMS dynamic data is very consistent for
 - 34E/1T on Stage 2
 - 10E/1B on Stage 3
- NSMS dynamic data is somewhat inconsistent for
 - 54E/3B on Stage 2
 - Disk or any other simultaneous mode participation requires more probes installed
- NSMS dynamic data shows buffeting on Stage 1
 - Due to blades being unloaded since IGV is at home position
 - Lower levels of buffeting on Stage 2 and 3 as flow is smoothed
- Limited telemetry data confirms modes seen by NSMS
- NSMS beam interrupt probe design validated
- Installation in progress for full complement of probes for all 3 stages