

# Space Shuttle GN&C Development History and Evolution

Douglas Zimpfer<sup>1</sup> and Phil Hattis<sup>2</sup>  
*Draper Laboratory, Cambridge, Ma 02139*

John Ruppert<sup>3</sup>  
*NASA Johnson Space Center, Houston, Tx 77058*

*and*

Don Gavert<sup>4</sup>  
*Boeing (retired), Huntington Beach, Ca. 92647*



April 12, 1981 (STS-1) – July 21, 2011 (STS-135)

## Abstract

Completion of the final Space Shuttle flight marks the end of a significant era in Human Spaceflight. Developed in the 1970's, first launched in 1981, the Space Shuttle embodies many significant engineering achievements. One of these is the development and operation of the first extensive fly-by-wire human space transportation Guidance, Navigation and Control (GN&C) System. Development of the Space Shuttle GN&C represented first time inclusions of modern techniques for electronics, software, algorithms, systems and management in a complex system. Numerous technical design trades and lessons learned continue to drive current vehicle development. For example, the Space Shuttle GN&C system incorporated redundant systems, complex algorithms and flight software rigorously verified through integrated vehicle simulations and avionics integration testing techniques. Over the past thirty years, the Shuttle GN&C continued to go through a series of upgrades to improve safety, performance and to enable the complex flight operations required for assembly of the international space station. Upgrades to the GN&C ranged from the addition of nose wheel steering to modifications that extend capabilities to control of the large flexible configurations while being docked to the Space Station. This paper provides a history of the development and evolution of the Space Shuttle GN&C system. Emphasis is placed on key architecture decisions, design trades and the lessons learned for future complex space transportation system developments. Finally, some of the interesting flight operations experience is provided to inform future developers of flight experiences.

---

<sup>1</sup> Associate Director, Space Systems, 17629 El Camino Real, Houston, TX 77058 and AIAA Associate Fellow.

<sup>2</sup> Laboratory Technical Staff and former Shuttle Orbit Flight Control Technical Leader, Dynamic Systems & Control Division, 555 Technology Square, Cambridge, MA, 02139, and AIAA Lifetime Fellow.

<sup>3</sup> Deputy Branch Chief, Integrated GN&C, 2101 NASA Parkway, Houston, Tx 77586/EG4.

<sup>4</sup> Former GN&C Supervisor, Rockwell International Space Division, Downey Ca. 90240.

## I. Introduction

The Space Transportation System (STS) or Shuttle is comprised of the Orbiter, External Tank (ET), and Solid Rocket Boosters (SRB). It is my far the most unique and technologically challenging vehicle developed for safely transporting humans and cargo (payload bay is 60 ft by 15 ft) to and from Low Earth Orbit (LEO). Weighing in at over 4.5 million pounds at liftoff, the Shuttle was designed to be reusable except for the external tank, perform complex on-orbit operations including rendezvous and docking, mated Orbiter/Space Station control, then de-orbit and execute a non-powered precision landing at 200 knots. One key system that contributed to the thirty year Shuttle success story is the GN&C system. Design and implementation of a robust Shuttle GN&C system capable of performing all mission phases was an engineer's dream challenge. Consequently, the Space Shuttle GN&C system is one of the most complex ever developed requiring an extensive GN&C system with an array of sensors, flight software algorithms and actuation systems. Even though the challenge began in the 1970's it did not cease after the first flight. GN&C evolution continued nearly the entire thirty years of operations due to flight experience revelations, ever-expanding on-orbit functions (space station, Hubble servicing, etc.), improving Orbiter performance, hardware obsolescence, and crew safety. Considering the multitude of GN&C system dependencies it is a remarkable achievement and testament to the engineers that took the challenge and created this flying wonder. Consider some of the challenges: airframe aerodynamics including large aero uncertainties in Mach regions with limited or no wind tunnel validation, the first fly-by-wire spacecraft, fail-op fail-safe (FO/FS) avionic architecture, limited aero surface actuator performance, reaction control system (RCS) sizing, limited general purpose computer (GPC) memory and throughput, 1970's era precision sensor hardware, requirements to fly manually and in "auto", in-flight abort capability, a separate primary and backup flight system, and much more. The Shuttle GN&C system is truly an engineering wonder that extols ingenuity and projects the "can do spirit" for future engineers and their challenges.

## II. Shuttle GN&C Compendium

Understanding the GN&C system rudiments begins with comprehending the Shuttle/Orbiter configuration, mission and the resultant impacts on the GN&C design. From the instant the Shuttle launches the GN&C system is in active control through the three Orbiter Program Segments (OPS) and multiple Major Modes (MM) until wheel stop (illustrated in Figure II.1).

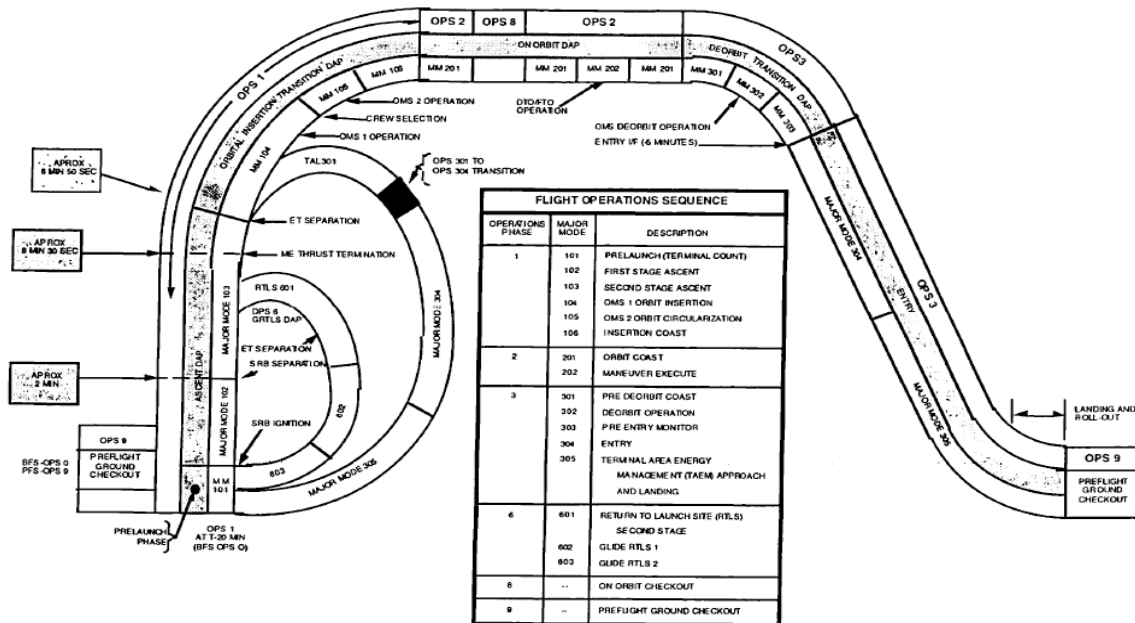
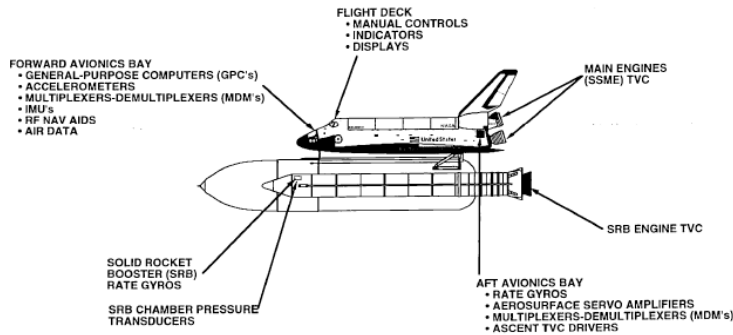

Figure II.1: Flight Operation Sequence and Major Modes

Each MM utilizes a unique GN&C configuration based upon sensors, effectors, guidance and control requirements, and whether operating in auto or manual mode. Figure II.2 details some of the GN&C hardware and related hardware required to successfully operate the Shuttle. Navigation hardware includes: inertial measurement units (IMU's), which sense vehicle orientation and accelerations; star trackers, determine vehicle line of sight vectors; Crew Optical Alignment Sight (COAS), allows the crew to manually determine line of sight vectors; Tactical Air Navigation (TACAN), determines vehicle position with respect to a ground based station; Global Positioning System (GPS), satellite ranging signals to determine orbiter position and velocity; air data system (ADS), which senses temperature and pressure; microwave scan beam landing system (MSBLS), determine slant range, azimuth

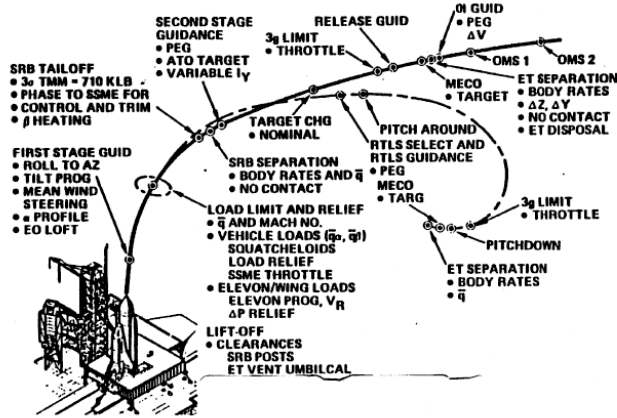

**Figure II.2: Shuttle GN&C Hardware**

The digital autopilot (DAP) is the flight control software that generates commands for the appropriate effectors. There are different DAP's for different flight phases: Transition DAP (TRANSDAP) becomes active at MECO and is used again for the deorbit burn until Entry Interface (EI) minus five minutes; orbit DAP includes an RCS DAP, an OMS TVC DAP, and an attitude processor module; Aerojet DAP is used from EI-5 until wheel stop. Flight control receives commands from guidance software or from the crew controllers (attitudes, rates, and accelerations) and converts them to effector commands. Flight control output commands are based on the difference between the commanded attitude, body rate, or body acceleration and the sensed attitude, rate, or acceleration. Sensed attitude is derived from inertial measurement unit (IMU) angles; body rates are sensed by rate gyro assemblies (RGAs); and accelerations are sensed by accelerometer assemblies (AAs). In addition, during atmospheric flight, flight control adjusts control sensitivity based on air data parameters derived from local pressures sensed by air data probes and performs turn coordination using body attitude angles derived from IMU angles.

The ascent flight phase (OPS 1) commences at liftoff (MM102) and ends with orbit insertion coast (MM106).

**Ascent GN&C Functions**



**Figure II.3 Ascent/Abort Profiles**

and desired body rates. Sensed acceleration is collected from the Orbiter's four accelerometer assemblies (AA's)

and elevation to the ground stations alongside the landing runway; and radar altimeters. The flight control system hardware includes four accelerometer assemblies (AA's), four orbiter rate gyro assemblies (RGA's), four SRB rate gyro assemblies (SRGA's), rotational and translational hand controllers, rudder pedal transducer assemblies, two speedbrake/thrust controllers, two body flap switches, panel trim switches, aero surface servo amplifiers, and ascent thrust vector control (TVC).

Figure II.3 illustrates ascent/abort profiles. During ascent, Orbiter control and trajectory changes are made during powered flight by commands sent to the SRB and SSME thrust vector controllers (TVC). After main engine cutoff (MECO) control and trajectory corrections are made by commanding the OMS engines and RCS jets. Ascent first stage (MM102) duration is from liftoff till SRB jettison, approximately 2 minutes, during which the open loop guidance computes attitude commands from a predetermined trajectory (attitude vs. velocity profile) based on a trajectory shaped for loads. The IMU's provide the current vehicle state (position, velocity) to the guidance and flight control. Flight control receives the guidance attitude commands, sensor outputs and generates

actuator commands based on the attitude errors

and body rates are collected from the four solid rocket booster rate gyro assemblies (SRGA's). The SRGA's are used during first stage because they are less susceptible to errors created by structural bending since the SRB's are more rigid than the Orbiter body. At approximately 120 seconds after launch the SRB's are jettisoned and MM103 (second stage) begins. Second stage lasts approximately six and one half minutes and ends at main engine cutoff (MECO) and ET separation when MM104 begins. During second stage, guidance is closed loop generating commands to meet the MECO target condition via the guidance algorithm called "Powered Explicit Guidance". The target conditions include cutoff velocity, radius from the Earth, flight path angle, orbital inclination, and longitude of the ascending node. Navigation and control remain the same as first stage with the exception of no longer commanding the SRB's TVC. After MM103 completion the Orbiter continues its trajectory into LEO by either one or two burns of the Orbital Maneuvering System (OMS). MM 104 (Orbit insertion), OMS-1 burn, is used to raise the orbiter energy to permission selected apogee altitude. For direct insertion ascent the OMS-1 burn is usually not required. MM 105 (orbit circularization), OMS 2 burn, raises the perigee altitude to create a circular orbit. TRANSDAP is used during orbit insertion, and de-orbit phase MM301-303, commanding the OMS TVC and the RCS jets to perform insertion and deorbit burns, attitude maneuvering and translational maneuvers, including separation of the Orbiter from the ET.

During ascent, abort return to launch site (RTL) and abort trans-Atlantic (TAL) are possible for predetermined failures. A specific set of guidance and control algorithms were developed for the different abort profiles.

OPS 2 is the operational sequence for on-orbit operations (illustrated by Figure II.4). It is comprised of MM 201 (orbit coast) and MM 202 (maneuver execute). MM 201 functionally monitors and controls the Orbiter during coast flight and experiment operations while MM 202 is used for maneuvering to OMS burn attitudes and orbital translations. During on orbit operations the navigation software propagates the Orbiter state vector using IMU data

**Figure II.4 On Orbit Major Modes**

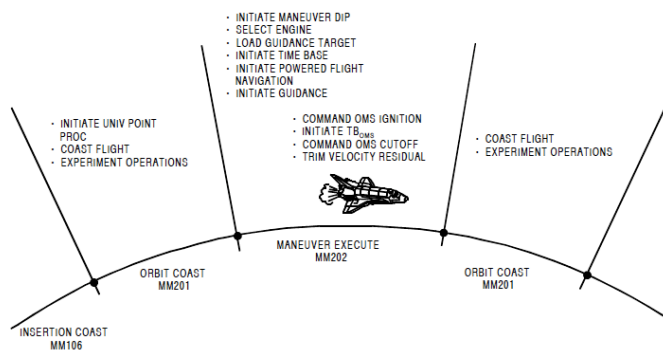

and models of atmospheric drag acceleration. Due to the accuracy of the IMU's and modeled drag periodic updates are sent from Mission Control to correct for errors. During rendezvous operation rendezvous navigation utilizing data from the star tracker, crewman optical alignment sight (COAS) or rendezvous radar to compute the Orbiter target state vector. Orbiter control and maneuvering is maintained through the use of the RCS jets, OMS engines, and the smaller vernier jets.

deorbit, entry and landing (illustrated by Figure II.5). The deorbit phase includes the deorbit burn preparations (MM301), loading of burn targets and maneuvering to burn attitude; execution and monitoring of the burn (MM302); reconfiguration after the burn; and a coast mode (MM303) until entry interface (EI ~ 400,000 ft altitude)

**Figure II. 5 De-Orbit Pre-Entry Major Modes**

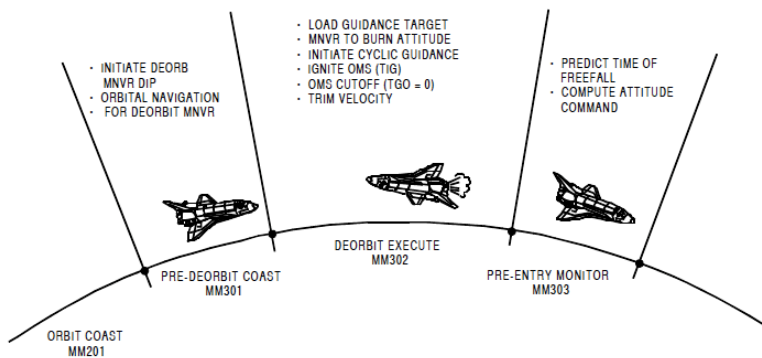

OPS 3 is the operational sequence for minus five minutes is reached (MM304).

As mentioned previously the deorbit phase uses the TRANSDAP controller. Navigation uses the Super-G algorithm to propagate the orbiter state vector, based upon a drag model or IMU data. The entry phase (MM 304) of flight begins at EI minus five minutes and continues until terminal area energy management (TAEM) interface (MM305) is reached (Mach 2.5, Alt. ~ 83,000 ft). At an altitude of approximately 10,000

ft. the flight phase changes to Approach and Landing (A/L), which continues until wheel stop. Nominal end of mission events are illustrated in figure II.6. Control is maintained by the aft reaction control system (RCS) until a sensed dynamic pressure of 2 psf where control is performed by blending RCS and elevator/aileron aerosurfaces.

During entry the forward RCS jets are inhibited as are the vernier jets. The body flap becomes active at a dynamic pressure of 0.5 psf. It is used as a heat shield for the SSME bells and for pitch trim augmentation to support elevon deflection during high heating regions. Beginning with a dynamic pressure of 10 psf the roll jets are deactivated, at

**Figure II.6 Nominal End of Mission Events**

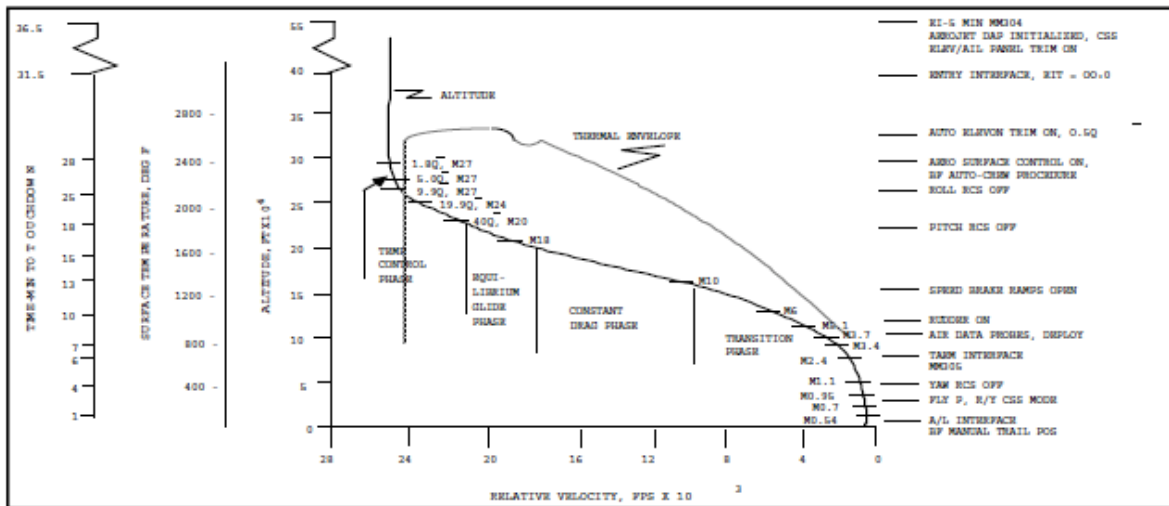

40 psf the pitch jets are deactivated, finally at Mach 1 the yaw jets are deactivated. The speedbrake becomes active at Mach 10 and is fully opened to augment pitch trim. It is used for energy control during heading alignment cone (HAC) flight and provides pitch moment augmentation during slap down. The guidance function varies depending on entry sub phases. During entry guidance commands a drag/acceleration profile based on temperature, dynamic pressure, angle of attack ( $\alpha$ ), and normal acceleration ( $N_z$ ). It then generates roll angle and angle-of-attack commands for use by the flight control system. During TAEM the primary function of guidance is to manage the Orbiter's energy in order to achieve the proper approach and landing (A/L) conditions. If the Orbiter is high on energy S-turns are commanded prior to HAC acquisition to dissipate the excess energy.

**Figures II.7,8 TAEM & A/L**

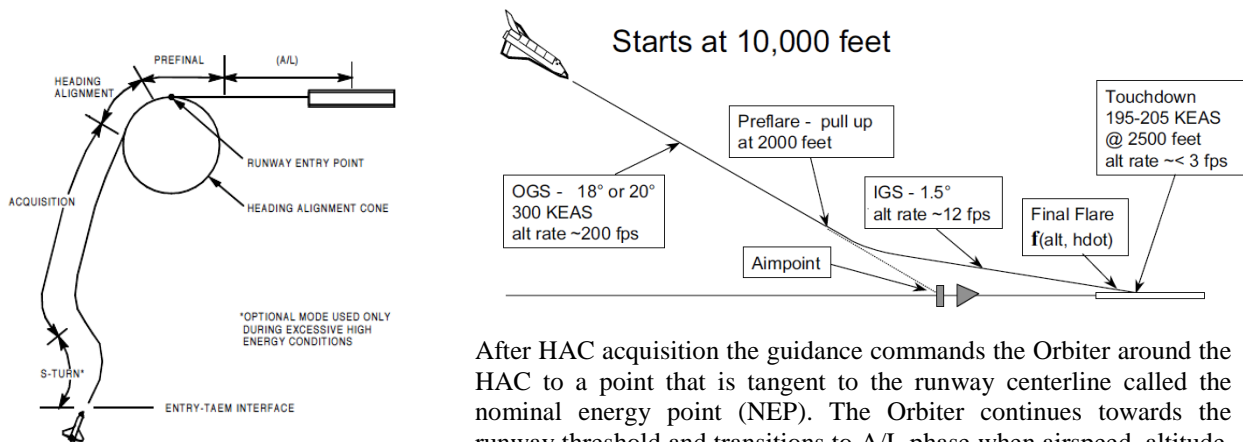

guidance maintains the proper glide slope, speed, and tracks the runway centerline. At an altitude of 2,000 ft. the pre-flare pull up is commanded reducing the altitude rate from 200 ft/sec to 12 ft/sec. Final flare is initiated at an altitude between 30 ft to 80 ft reducing the sink rate to 3 ft/sec (illustrated in figures II.7,8). At main wheel touchdown the weight on wheels flag is set and just prior to de-rotation the drag chute is deployed. At nose gear touchdown the software transitions to rollout mode and active nose wheel steering is available.

### III. Development, The Early Years

The early years of the Shuttle GN&C development covers the period from initial development in the early seventies through the initial flights in the early eighties until the Challenger Accident. During this period substantial advancements were made to incorporate the current technologies of the time to achieve the extensive requirements necessary for a digital fly-by-wire reusable space vehicle including ascent, orbit and entry, descent and landing flight operations.

Crew safety and mission success were primary design drivers resulting in an architecture that supports a FO/FS philosophy. In addition, the architecture incorporated manual and auto mode flight control systems, an independent Backup Flight System (BFS), digital fly-by-wire, abort capability, and redundant management system that could detect faults, identify the faults and reconfigure (FDIR) the system. To meet the FO/FS requirement a four-string avionics architecture was developed. The immediate GN&C impact meant four redundant pieces of hardware, where possible, synced together with fault management logic. Exceptions were the three inertial measurement units (IMU), aero-surface actuators, switches, displays, hand controllers, and the BFS that is single string. The data processing system (DPS) is comprised of the primary flight system (PFS) and the BFS. The PFS is a quad redundant architecture utilizing a redundant set of four general-purpose computers (GPC's) while the BFS is single string with its own dedicated GPC. NASA, Rockwell, Draper Laboratory and Honeywell developed the primary GN&C which was coded into software by IBM while Rockwell International and Draper Laboratory developed the BFS software. Independent programming was pursued to minimize potential generic programming errors that could result in complete loss of command and control capability. Due to limited GPC memory the entire flight software for ascent, on orbit, entry, and aborts could not be loaded in one seamless package. The work around was development of flight operational software loads (OPS) that are loaded onto the GPC's for each flight phase. The GN&C is a true fly-by-wire system with all command and control generated by the flight software. There is no direct command linkage to the controllers. The PFS digital autopilot (DAP) can operate in the auto mode or in control stick steering (CSS) also known as the manual mode. It can also mix the modes per control axis and function while BFS is solely operated in the CSS mode.

#### Ascent GN&C

The ascent GN&C requirements can be simplified to “deliver the Orbiter” to: 1) desired orbit insertion conditions; 2) desired position and velocity for an abort landing; and 3) any stable orbit for an abort to orbit (AOA).

**Figure III.1 Ascent GN&C Tasks**

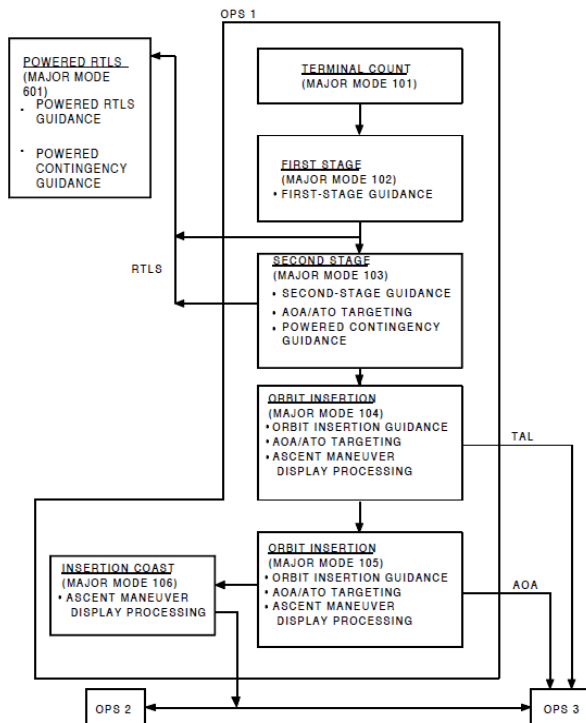

Constraints levied were: 1) no recontact with launch pad; 2) maintain aerodynamic loads within structural capability; 3) meet specific attitude and rates at SRB separation; 4) maintain attitude within thermal attitude constraint; 5) maintain axial acceleration below 3 g's; 6) meet specific attitude and rates at ET separation; 7) meet ET disposal criteria; 8) maintain RTLS trajectory within fly back range and dynamic pressure constraints; 9) meet RTLS MECO mass constraint; and 10) provide modal suppression and/or attenuation as required for dynamic stability. Figure III.1 is a simplified flow diagram of the ascent task.

Early GN&C development focused on TVC command loops, propellant slosh effects, modal effects, incorporating day of launch wind effects, abort modes, manual take over, and meeting staging interface requirements.

The ascent FCS incorporates a classical “proportional plus derivative” feedback control law. Several types of digital filters are implemented on the rate gyro outputs to attenuate undesirable higher frequency components due to vehicle flexible body dynamics. The filter designs were a balancing act because the rigid body bandpass and the flexible vehicle dynamics were close in proximity. Another challenge was the requirement to ensure phase

stabilization of the fuel slosh dynamics which fell within the rigid body bandpass. Generally, the higher levels of attenuation in the flex dynamics frequency came at the expense of increased phase lag in the rigid body/slosh frequency range. The filters were under constant scrutiny and change due to the multitude of payloads that were flown.

The ascent thrust vector control (ATVC) command loop from the beginning required extensive analysis. It is a critical loop that requires knowledge of the hydraulic system, actuator characteristics, sensor characteristics, SSME and SRB thrust profiles, and the effects of system failures. The flight control hydraulic laboratory (FCHL) at Rockwell Downey was extensively used in designing the specific gains required for the TVC algorithms. This unique laboratory was capable of varying actuator loads, instilling hydraulic failures, and applying various system lags and biases.

A major Ascent GN&C update occurred when the super light weight tank (SLWT) was introduced. It was 15% less stiff than the original tank therefore affecting slosh stability margins. Changes were made to the controller filters, a slosh/flex coupling term was added, and the removal of a slosh induced moment term in the roll equation of motion. This is a prime example of a system that evolves, in this case it was the external tank, and the effects it had on the controller filters and gains.

Separation dynamics was another region that required extensive analysis and G&C updates. During SRB separation it became a necessity to fire the forward Orbiter RCS jets in order to prevent window contamination from the SRB separation motors. Also, when new SRB separation motors were installed further analysis was required to insure no new dynamics were being introduced. ET separation was another region that required updates and extensive analysis. The main concern was recontact when there was an RCS jet failure, especially during an RTLS abort. Changes were made to timers, gains, and jet select logic.

### On-orbit GN&C

The On-orbit GN&C (OGNC) system significantly leveraged the capabilities developed for the Apollo moon landings. To achieve this efficiently, the responsibility for development of the OGNC was completed under track task by NASA and the Draper Laboratory with oversight by prime contractor RI. The OGNC and its sister functions incorporated in the Transition DAP, performed all functions following MECO, on orbit operations, deorbit and preparations for entry. Significant flight operations included payload deployment, rendezvous and proximity operations and capture of free flyers with the remote manipulator system. Although it significantly leveraged the Apollo OGNC, the Shuttle system incorporated several new capabilities to improve operational flexibility and efficiency.

The Space Shuttle navigation system leveraged the Apollo inertial state Kalman Filter with periodic state updates via ground uplinks, but state noise was incorporated to improve onboard covariance calculations. For relative navigation the techniques used for the Apollo Lunar orbit rendezvous were adapted for Earth orbit rendezvous including incorporating a rendezvous radar system (illustrated by figure III.2). Guidance algorithms provided the capability for closed-loop powered explicit guidance (PEG) using a linear tangent method and rendezvous targeting algorithms. The control system or Orbit Digital Autopilot (ODAP) expanded on Phase Plane reaction control system (illustrated by figure III.3) methods employed for Apollo, but incorporated several new features to improve thruster duty cycles for the reusable space vehicle.

A Kalman filter state estimator was used to derive vehicle rate and disturbance acceleration estimates. To limit the effects of filter lags on rate estimation, feed-forward estimates of expected rate changes due to commanded thruster firings were introduced into the Kalman filter.

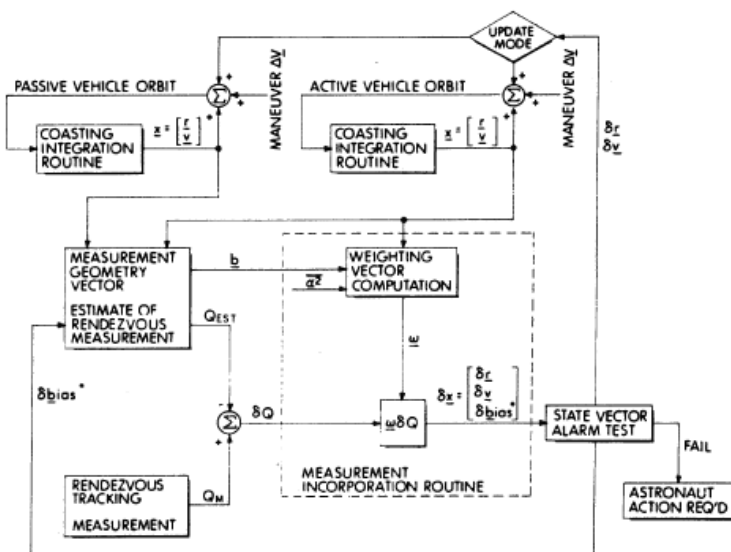
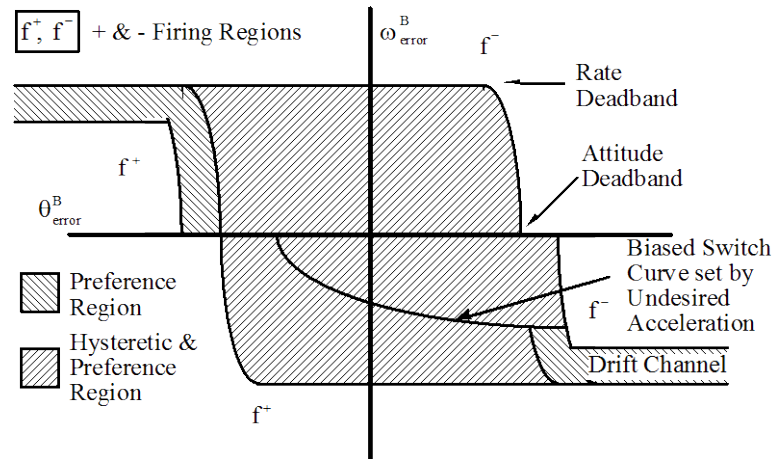

Figure III.2 Shuttle Rendezvous Navigation Filter



**Figure III.3 Orbit Phase Plane**

For all proximity operations the absence of close-in range sensors required that the crew continue to fly operations manually. Significant training and flight procedures were developed to provide the crew appropriate techniques for flying to within close proximity of payloads to allow their capture by the robotic arm. Docking was not a feature of the early Shuttle design.

While the OMS TVC was adapted from Apollo, the Shuttle-unique RCS configuration with thrusters pointing into 14 different directions required an entirely new table look-up-based jet selection algorithm. Major modifications to the Apollo phase plane control loop (combined axis-by-axis attitude error and attitude rate error tracking logic) were needed to address Shuttle hardware and operational environment effects. Also, the primary RCS control included a wrap-around of the OMS TVC loop to assure that the Shuttle fault tolerance requirements were fully met. Some specific primary RCS control loop design challenges included: Assuring stability of the OMS TVC wrap-around given fundamentally different OMS TVC and RCS control criteria; meeting control precision goals despite large minimum impulse values (driven by an 80 ms minimum thruster on time necessitated by unacceptable water hammer effects found to be possible in the propellant lines if shorter on/off cycle times were allowed); assuring sufficient control authority for the full spectrum of two-fault conditions. Some of the primary RCS fault tolerance demands resulted in application of novel, fault-driven, Boolean rule-based logic that directed the jet selection to acceptable look-up tables for specific classes of fault combinations.

The vernier RCS control loop, in its initial flight implementation, provided a dedicated fine-rotation control loop that was unique to the Shuttle. Taking advantage of its configuration of 6 thrusters that pointed into six different directions, it used a new, and deceptively simple “dot product” selection logic that picked 1 to 3 thrusters that produced a combined rotational acceleration closely aligned to the desired direction of control. While vernier jets were only commanded when at least one rotation control axis had an error in a phase plane zone mandating jet activity, whenever jets were commanded, the errors in all rotation axes were included in the dot product computation to promote overall pointing error reduction. The criteria for selecting a second and possibly third thrusters were tuned to the Shuttle’s vernier RCS configuration to assure that the level of acceleration alignment improvement and expected phase plane error reduction from their use improved overall vehicle propellant usage efficiency.

Another unique challenge for the OGNC developers was the requirements to provide attitude control while payloads were being manipulated by the Remote Manipulator System (RMS). The entire loaded RMS flexural frequency range was very near the open-loop cross-over frequency for the vernier RCS control system. This posed two problems: 1) Dynamic interaction between the structure and vernier RCS jets could excite unacceptable motion of the payload on the RMS. 2) High vernier RCS duty cycles could result from attempts to actively control the system. The first problem was recognized before any RMS flight operations occurred on the Shuttle, which led to careful screening, using high fidelity simulations with extended RMS structural models, of each planned RMS/extended payload configurations that planned to apply closed-loop vernier RCS attitude control. The second problem was only fully appreciated after the vernier RCS experienced excessive duty cycles on the STS-2 flight due in part to its use for closed-loop attitude control during commanded RMS motion with an extended payload. Subsequent flight procedures precluded closed-loop RCS attitude control during any commanded RMS motion which remained in effect for the life of the Shuttle.

The initial Shuttle flights also identified unique challenges for the OGNC. On the first 4 Shuttle missions, at the completion of the Space Shuttle Main Engine (SSME) burn, but before ET separation, the engine bells were slewed to their planned reentry positions at a frequency that turned out to be very close to a subharmonic of the rocking



frequency of the orbiter on the ET (despite pre-flight predictions to the contrary). Oscillatory orbiter motion excited by the SSME slewing caused rhythmic firing of the primary RCS jets in response to apparent cyclic violation/satisfaction of pre-separation rate limits. While the ET separation was successful on all the Shuttle flights, it occurred with much less safety margin than was originally intended on the first four flights until modifications could be made to rectify the problem.

During early flights analysis was also completed to determine the effects of the self impingement of the thruster plumes on the Orbiter surfaces. Early flights did not model the impact of the Body Flap on the aft down-firing vernier thrusters resulting in nearly 50% error in thrust estimation and significant increases in thruster duty cycle rates due to mis-modeled feed forward predictions and resultant errors in estimation of the disturbance accelerations. On STS-3 the plume was accounted for and significant improvements were observed. Ironically, these models appeared accurate until the first Shuttle/Mir docking flights when it was discovered that the errors still existed in the resultant X-axis of the jets which became observable with the significant shift in the mated stack Z center of gravity.

On STS-9, a test operation was conducted to demonstrate precise pointing with the primary thrusters. These operations uncovered an unmodeled lag in the IMU measurements which resulted in significant dual-pulse thruster firings at extremely high frequencies. The precise pointing operations were restricted using the Primary RCS until a software fix could be employed several years later.

### Entry through Landing GN&C

The initial shuttle guidance algorithms for entry through landing (E/L) were the products of various NASA and contractor disciplines. Entry guidance used during Major Mode 304 (i.e., post deorbit to the Terminal Area Energy Management (TAEM) interface) was primarily developed by NASA's Mission Planning and Analysis Division (MPAD) with support from Rockwell International's (RI) trajectory performance group. TAEM guidance then used to guide the orbiter to the Approach/Land (A/L) interface was primarily a McDonnell Douglas output with support from RI's Integrated Entry Guidance, Navigation and Control (IGN&C) group. A/L guidance used for landing was developed by Sperry Flight Systems with again support from RI's Entry IGN&C and Entry Flight Control groups. The only other entry related guidance function was the Glide Return to Launch Site (GRTLS) TAEM guidance. This latter function used only for aborts took advantage of the entry TAEM guidance scheme with added functions for handling the initial portion of descent post external tank separation. This guidance function was a joint product of NASA Engineering, McDonnell Douglas and RI. The actual E/L guidance requirements to be implemented by the Primary Avionics Software System (PASS) developer were then specified by Book 1 of RI's published Functional Subsystem Software Requirements (FSSR) documents. These requirements were also used to derive the E/L guidance to be implemented for the Backup Flight System (BFS) as were specified by a BFS Program Requirements Document (PRD). One notable omission for the BFS was A/L guidance.

Of the E/L guidance functions mentioned, the Entry guidance nominal end-of-mission (EOM) requirements have remained pretty much intact since first baselined. The most significant change made after initial baseline and prior to first flight was implementation of a so-called "alpha modulation" capability. This change allowed the pitch channel alpha command to have some small degree of variability rather than reflect a fixed alpha vs. relative velocity profile. This change gave the guidance an improved drag modulation capability especially if faced with transient conditions. Later in the shuttle program, Entry guidance was modified to enable an auto contingency Transatlantic Abort Landing (TAL) capability. Note that this contingency abort capability is not applicable to the BFS.

The TAEM and GRTLS TAEM guidance functions underwent likely the most significant change since first baselined when so-called Optional TAEM Targeting (OTT) was implemented for first use on STS-5. Prior to OTT, use of a Heading Alignment Cylinder (HAC) was employed to align the vehicle's heading with the runway. The vehicle would be steered to intercept the HAC and then commanded to follow the circumference (circle in ground plane) until runway alignment achieved. This targeting would always have the HAC turn be less than 180 degrees.

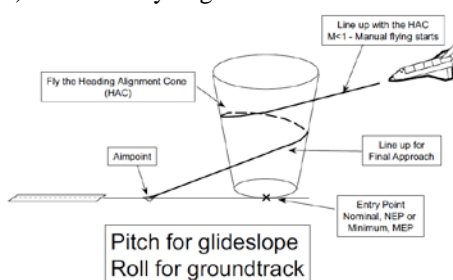

**Figure III.4 Heading Alignment Cone**

The most significant change made later in the program as applicable to both Entry and GRTLS TAEM was

A desire to have an improved weather avoidance capability led to the requirements implementation of OTT. This change allowed for HAC turns greater than 180 degrees ("overhead approach") with an option to revert to the prior guidance capability for a less than 180 degree ("straight-in") approach. To accommodate the higher velocity HAC intercept conditions seen for overhead approaches, the HAC itself was redefined to be a cone (spiral in ground plane). The change from a cylinder to a cone allowed continued use of the HAC acronym. (illustrated by figure III.4)

implementation of the so-called “smart speedbrake” change. This change allowed the closed-loop speedbrake command to use the same energy/weight reference employed to limit Nz pitch commands.

A/L guidance remains near identical to its initial operational definition. The only significant change was implementing an enhanced speedbrake controller meant to take into account factors affecting touchdown energy such as vehicle weight, sensed winds, density altitude, runway aim point and runway length.

As stated previously, A/L guidance is not present in the BFS. Since A/L guidance was meant to provide an auto landing capability, this aspect was not available with BFS since the BFS must be flown manually during entry. The BFS maintains TAEM guidance down to the where A/L would command Preflare (altitude of 2000 feet). From that point on the crew must rely on out-the-window cues for achieving touchdown with BFS.

The entry digital auto pilot (DAP) consists of an auto and manual mode selectable by axis, bodyflap and/or speedbrake. For example, a possible combination is: auto pitch axis with manual lateral axis, auto speedbrake and manual bodyflap. Control stick steering (CSS) is the manual mode that is a rate command system with a rate damping stability loop similar to what the auto system uses. Auto mode replaces the RHC generated rate commands with command rates computed from body roll angle errors in the lateral axis and angle of attack or Nz errors in the pitch axis depending on flight phase. Figure III.5 is a simplified pitch axis diagram. All three axis are of similar design consisting of: 1) rate command logic; 2) gains and filters; 3) trim logic; 4) bending filters; and 5) effector command with limiters.

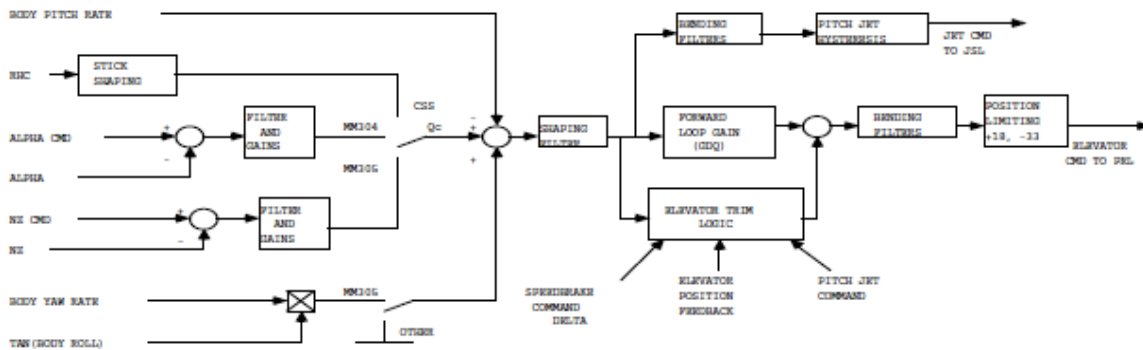

**Figure III.5 Simplified Pitch Axis**

Preliminary DAP design began in 1975 with work divided into the high Mach region (entry) and the terminal area/landing. The transition point was a moving target during the early design years with Mach 2.5 finally being agreed upon. Some early DAP design drivers were: aerodynamic uncertainties, RCS uncertainties, GPC limitations, lateral trim, flex body suppression, and pilot induced oscillation (PIO) suppression.

Aerodynamic uncertainties and data used to design the bending filters resulted in STS-1 flying with unique switches that allowed the pilot to modify the entry FCS real time. The switch functions would: 1) increase or reduce the forward loop gains on the aileron, rudder and elevator; 2) eliminate stability loop rate feedback; 3) add a angle of attack bias to the turn coordination logic; 4) freeze all aerodynamic surfaces; and 5) activate a no-yawjet lateral control logic. Aerodynamic uncertainties were also major factors when the rudder/speedbrake was to be activated, elevon scheduling, and the body flap schedule. Rudder activation was set at Mach 3.5 for STS-1 and later changed to Mach 5.0 only after several flight detailed test objectives (DTO's) were performed reducing the aero uncertainties.

Due to the PIO seen on the last approach/land flight test (ALT) changes were incorporated into the FCS to mitigate the probability of it occurring. First change was the elevator priority rate limiting (PRL) that prevented one axis from locking another axis out. PRL logic is a necessity due to limited rate capability of the Orbiter actuation system. A second modification doubled the RHC sampling rate from 12.5 to 25 samples per second. This effectively reduced the computer transport lag. Transport lag was significant contributor to the PIO. Next a nonlinear filter was applied to the RHC output to attenuate oscillatory inputs and the pitch forward gain was reduced.

Bending filter modifications were applied to all three axes. For the pitch axis only the filter coefficients were changed however structural changes were made to the roll and yaw axis. In the yaw axis separate fourth order filters were created for the yaw jets and rudder. This took advantage of a new yaw jet minimum on time thereby reducing required attenuation resulting in changes to the yaw jet bending filter coefficients. For the roll axis a separate fourth order bending filter was added to the roll jets. The aileron loop created a second order filter for subsonic flight, a sixth order filter for  $1.0 < \text{Mach} < 3.5$ , and a different sixth order filter for  $\text{Mach} > 3.5$ . Due to the lower dynamic pressure a large aileron forward loop gain is required for  $\text{Mach} > 3.5$  to achieve the desired transient response. The

higher gain requires an increase in the filter attenuation of the flex modes. In the lower supersonic region the gain is lower therefore a reduced attenuation is required resulting in rigid body phase lag reduction.

Other pre-STs-1 modifications included an increase in the rudder forward loop gain; modifications to the lateral trim loop and turn coordination, and removal of a boosted lateral acceleration signal feedback from the yaw axis and the steady state signal from the roll axis.

### ***Preflight Test Operations***

E/L GN&C requirements were tested through basically a two-step process. The initial stage involved almost exclusively non-real-time (NRT) mathematical model simulations focusing on defined requirements and capabilities. Multiple independent simulations were involved and included both 3 degree-of-freedom (3DoF) and 6 degree-of-freedom (6DoF) capabilities. Additionally, there were 6DoF man-in-the-loop simulations to enable assessments of cockpit operations and manual flying. Both nominal and stress tests were repeatedly performed to ascertain strengths and weaknesses inherent in the proposed GN&C architecture and algorithms. Arising from this initial efforts were optimal trajectory profiles for achieving desired performance goals while maintaining system and vehicle constraints across the breadth of potential conditions to be encountered. Additionally, stability analyses were performed for the guidance and FCS as independent entities and as an integrated system to insure classic gain and phase margins were maintained across the spectrum of defined trajectory profiles and flight envelopes. These early tests did uncover weaknesses whether functional of relative to performance leading to GN&C design changes to correct or at least mitigate the identified concerns. Once actual flight software was developed and delivered by the PASS and BFS S/W contractors, this software was then tested in a sophisticated real-time, man-in-the-loop laboratory environment at RI's Flight Simulation Laboratory (FSL) in support of E/L GN&C verification. It was through this myriad of test and evaluation activities that led to confidence in the fundamental GN&C design. This strategy is something that seemingly is a critical element to any downstream design activity.

## **IV. Upgrading to Improve Safety, Reduce Operations and Extend Capability**

Following the Challenger Accident a series of upgrades were made to improve the safety of the Space Shuttle operations. These were followed by improvements that reduced flight operations and/or extended the capabilities of the GN&C system to meet future operational needs, primarily the assembly of the International Space Station.

### ***Aborts***

Prior to STS-1 the need for a trans-Atlantic intact abort (TAL) was evident. A manual procedure was developed for STS-1 and STS-2 that evolved into an automated mode for STS-3 and subsequent missions. The TAL transition occurs at MM104 (illustrated in figure IV.1) after the main propulsion system dump. The Orbiter GPC's are loaded with the MM304 software during which the Orbiter is in free drift with no active control. At the start of a TAL the Orbiter attitude is similar to a GRTLS attitude meaning a low angle of attack thus requiring a similar pull-up maneuver.

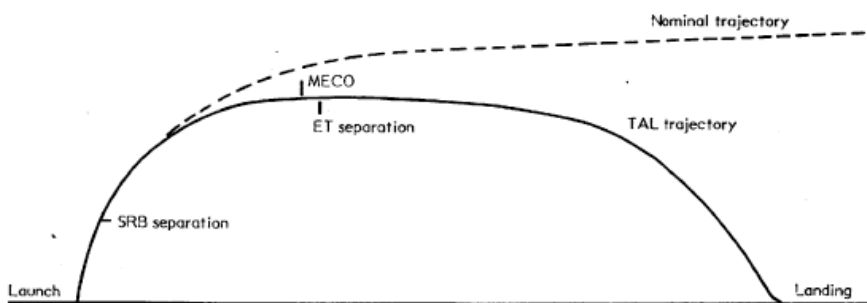

**Figure IV.1 TAL**

For GRTLS TAEM, a late program functionality addition was providing an automatic contingency abort capability named East Coast Abort Landing (ECAL). Note that this contingency abort capability is not applicable to the BFS.

The entry DAP was modified by increasing the pitch rate gain to improve the pull-up maneuver, a TAL alpha error gain was added, and the alpha error lag-lead filter was deactivated until Mach 20. Additional changes were made to guidance that is TAL unique.

### Landing/Rollout

Two significant modifications to the landing rollout system can be attributed to two flight incidents. The STS-3 “wheelie” and the blown tire on STS-51D. The STS-3 “wheelie” occurred during derotation after main tire touchdown. After touchdown the nose derotation was greater than anticipated therefore the pilot pulled back on the RHC slightly with no response whereby he increased the RHC input. The Orbiter pitched up quickly (i.e. wheelie) causing the pilot to put a full forward RHC command into the system. Post flight analysis indicated Orbiter response

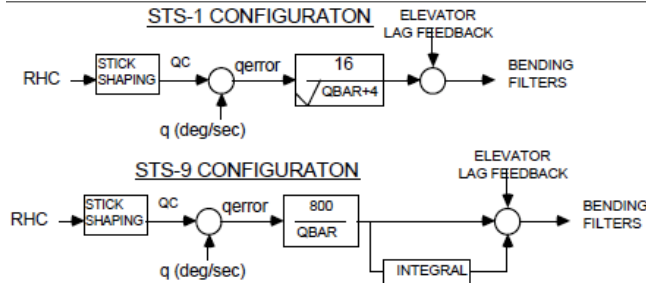

**Figure IV.2 Derotation Logic**

Prior to STS-61A differential braking provided lateral steering during rollout. During the rollout of STS-51D one of the main tires blew caused mainly by the overheating of the brakes resulting from the differential braking. Modifications to the Orbiter nose wheel steering (NWS) required upgrades to the rudder pedal transducers, new hardware to measure the nosewheel position and feed it back to the GPC, NWS software addition to detect failures (transition to caster mode), and the change from an open loop to a closed loop lateral acceleration feedback system. Several years later the nosewheel steering was upgraded by adding a second nosewheel command path for redundancy. The upgrade removed the manual direct mode.

A drag chute was added to the Orbiter to improve landing capability. Drag chute benefits include reduced stopping distance, less aggressive braking, reduced main gear loads, and a more benign derotation rate thus decreasing slap down loads. To ensure the drag chute cleared the SSME bells during deployment software logic was added to lower the SSME bells during entry. This also required an update to the priority rate limiting (PRL) logic.

### Day of Launch I-Load Update (DOLILU)

The original DOLILU (1991) process re-centered the ascent trajectory by updating the guidance algorithms. DOLILU II (1995) updated both the ascent guidance algorithms and the first stage SSME throttle profile. DOLILU II eliminated the need for mission specific reconfiguration of first stage flight design I-loads and improved launch probability by defining dynamic pressure more accurately on the day of launch. Day of launch (DOL) I-loads are generated from the measured winds and atmosphere of the L-4 and L-2 atmospheric balloons.

### Rendezvous and Docking

In the late eighties it was identified that the Space Shuttle ability to capture and in the future dock with target spacecraft could be improved if recent advances in LIDAR technology were incorporated. This desire resulted in the

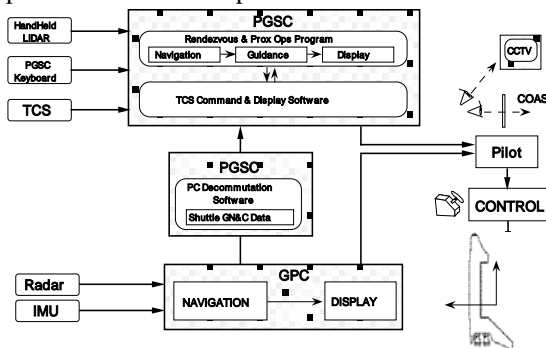

**Figure IV.3 Piloting Aid System Overview**  
NASA in-house development of the Trajectory Control Sensor (TCS). These developments led to a series of

was due to low gain on the elevator proportional loop in addition linear analysis showed the system was not stable at low pitch angles. Control loop changes included an increase in elevator loop gain and the addition of an integral term (illustrated in figure IV.2). The modified CSS loop is similar in structure to the auto loop. The new slap down control loop was first flown on STS-9 with no further incidents.



**Figure IV.4 RPOP Trajectory Display**

upgrades to the proximity operations and approach capabilities of the Orbiter, albeit never incorporating Autonomous Rendezvous and Docking due to the single-string nature of the TCS and the costs required to fully integrate the new sensor hardware into the data processing system.

To fully utilize the TCS and Hand-held LIDARS (HHL) used for later missions, the Rendezvous and Proximity Operations Program (RPOP) was developed. RPOP utilized a laptop PC tied into the TCS through a downlink communication box and employed situational awareness tools to aid Shuttle crews during proximity operations and approach. RPOP incorporated sophisticated guidance and navigation software that provided tools for the crew to visualize the approach trajectory and provide precise range and range rate information for precise rate docking (illustrated in Figures IV.3&4).

### ***Space Station Assembly***

During the early development phase of the OGNC it was discovered that deploying large (>8K lb) payloads on the Shuttle RMS caused undesired interactions between the Shuttle control system and the vehicle dynamics. As NASA began to investigate building Space Station Freedom and subsequently the International Space Station (ISS), additional dynamic interaction problems were identified. The OGNC went through a systematic series of upgrades to the flight control system to enable these challenging missions. These upgrades were responsible for the success of several Shuttle flights, including the Hubble Servicing missions, the Shuttle/Mir docking missions, the Space Radar Topography mission and finally the assembly of the ISS. The upgrades addressed a wide range of problems including operability, controllability, stability and induced loads. These efforts, combined with the improvements made for rendezvous and docking have developed many necessary features to enable subsequent potentially challenging mission operations (Table IV.1).

Table IV.1 – Shuttle Assembly Flight Control Upgrades

Title	Function	Description
Alt PRCS	Loads	Implemented load efficient pulsing of the PRCS jets to enable control with reduced structural loads.
Minimum Angle Jet Selection	Control	Improved control by aligning resultant acceleration with desired acceleration
Notch Filters	Stability	Provided stability by minimizing structurally induced feedback in the rate estimate
Reboost	Operability, Loads	Provided an automated reboost operation within structural loads
Feed Forward	Control, Stability	Improved performance when using the Notch Filters
Onboard Mass Props	Operability	Calculated thruster accelerations onboard to simplify uplink of the vehicle configuration

## **V. Flight Experience**

### ***Shuttle/MIR***

The Shuttle/Mir program was developed to demonstrate the ability of NASA and the Russian Space Agency to work together as concepts of the ISS were developed. In addition to the geopolitical benefits this program provided an excellent proving grounds for many GN&C capabilities necessary for assembly of the ISS.



**Picture V.1 Shuttle/Mir Docked**

The Shuttle/Mir program provided the first opportunity for a Shuttle to dock (picture V.1) with another space vehicle. Operational and engineering techniques were developed to routinely perform docking. The OGNC upgrades developed to enable rendezvous and docking were matured and demonstrated. Several techniques for Vbar and Rbar dockings were proven and refined. Analysis techniques for plume impingement from Shuttle approach firings were developed and proven through tests, including the ability to adapt to modifications in the flight operations. The post-contact docking technique and software were developed, implemented and tested in a rapid cycle to enable the first docking flight.

All of the OGNC upgrades developed to enable assembly of large structures in orbit were tested and proven on the Shuttle/Mir flights. From the very initial operations following the first docking the upgrades were relied upon to provide stable flight control of the largest structure ever flown in space to that date. Additionally, test operations were performed that demonstrated all of the upgrades including the Alt PRCS mode and jet selection upgrade.

The Shuttle/Mir flights provided an excellent proving ground to make routine many of the OGNC capabilities necessary to enable the assembly of the ISS.

### ***ISS Assembly***

The ISS assembly missions, occurring over more than ten years, demonstrated the flexibility of the Space Shuttle GN&CA multitude of missions were completed utilizing a GN&C system that had evolved and matured over its



thirty year life to complete a series of missions never envisioned by the original designers. The OGNC went through a significant series of upgrades to enable stable control, while meeting significant peak and life load constraints. Significant operational flexibility was incorporated to accommodate the wide range of assembly configurations. Operational flexibility of DOLILU increased launch probability and robustness was incorporated to deal with many operational changes, like rendezvous on Flight 2A with the Node already mated to the Orbiter, controlling with partially deployed solar arrays on 4A and providing backup control when the ISS temporarily lost its redundant Russian Computer Complex. The assembly of the ISS offers the pinnacle in demonstration of the Shuttle GN&C capabilities. (picture V.2)

**Picture V.2 Orbiter/Space Station Assembly Complete**

## **VI. Lessons Learned**

**Flight Test Program** - Flight tests with proper instrumentation are crucial to thoroughly validate a vehicle's operational viability. The lesson learned from Shuttle is without a proper flight test program reaching the goal of "operational" is slow and costly. Due to the lack of a "standard" flight test program early Orbiter flights required a set of programmed test inputs (PTI's) to verify the entry aerodynamic database and expand the longitudinal center of gravity. PTI's were flown through STS-51F. Due to crew safety the aggressiveness of the PTI's were tempered and the lack of proper flight test sensors hampered the post test analysis. A major system that never was verified by a flight test was the autoland system.

**Independent Primary and Backup Flight Systems** – The concept was worthy of it's time however it also proved to be a major validation and verification effort. The BFS was to be flown manually, it was single string, and the transition from PFS to BFS was to be seamless. Lesson learned was the tremendous effort to validate and verify Orbiter control during the transition from PFS to BFS. It was not as seamless as first invisioned.

**Use of Uncertainties** – The use of uncertainties in the design, analysis, and verification process is a necessity. The lesson learned from Shuttle is need to use uncertainties or risk catastrophic results.

**Functional evolution** – The GN&C system functionally expanded as the program progressed. Lesson learned is the need to have a GN&C architecture that can be functionally expanded. Examples for Shuttle: addition of a drag chute, active nosewheel steering and the inability to add sensors to the wheel/strut, DAP and guidance algorithm additions/modifications, and adding additional manual command and control capabilities. In some cases compromises were required because there was no way to add sensors to the system. Costly to add after the fact.

**Early prototypes, development and Integration** – Over the course of the Shuttle development significant capabilities were developed to allow early prototype and simulation of new GN&C capabilities. These early efforts have been essential to the successful implementation of new capabilities into the vehicle.

**Early Evaluation of Software Sizing** – Although the Shuttle processing capabilities are minimal by today's capabilities it was intended to be very capable during early development. Still expected software functionality exceeding the capabilities and a software scrub was conducted prior to first flight. Current programs need to be aware that software functionality needs to be appropriately managed within the capabilities of the processing elements.

**Program objectives will evolve** – The OGNC underwent extensive evolution to perform all of the objectives over the life of the program. A modular approach to the functionality had been developed which allowed for reasonable incremental upgrades. Any new program is likely to face changes in objectives over an extended life and care should be taken to accommodate evolution through modular architecture and implementation.

**Early Flight Data** – Early Shuttle flights encountered unexpected flight environments and demonstrated the significant benefits of obtaining flight test data. Additionally, anomaly resolution has demonstrated the need for extensive downlist and recorded data to resolve issues and the flexible reconfigurable data configurations have been essential.

## VII. Conclusion

With wheel-stop at KSC of the STS-135 mission, the Space Shuttle completed a storied career. The program achievements were many and varied, including the first reusable space transportation system, servicing of the Hubble Space Telescope and assembly of the International Space Station. The GN&C system contributed significantly to the success of the Space Shuttle program through its versatility, robustness and capability. The development of the Shuttle GN&C system leveraged many prior efforts, such as the Apollo OGNC, as well as set the stage for a next generation of GN&C capability. The Shuttle GN&C development efforts created an algorithm, simulation and analysis base that continues to be leveraged by GN&C developers today. The evolution and upgrades to the GN&C over the past three decades have contributed significantly to the program success, but also have provided a proving ground for new technologies and capabilities. The operational flexibility of the GN&C was demonstrated time again through the difficult missions it was asked to accomplish. Additionally, significant test and verification techniques have been developed using modern tools and capabilities which can be leveraged to enable future programs. Finally, The Shuttle GN&C provided significant lessons learned that can be applied to future space transportation systems, such as being proposed by the Commercial Crew Development program. For the many people who had the pleasure to participate in the development, evolution and operation of the Shuttle GN&C the past three decades have been an exciting time. Many organizations and individuals have contributed to the success of the GN&C and great pride can be taken in what has been accomplished and the contributions made to laying the ground work for future human spaceflight missions.

## Acknowledgments

To acknowledge every individual who contributed to the Shuttle GN&C success story would take a book in itself. It is therefore with a special thank you that this paper acknowledges all those who developed and supported the Shuttle program.

## References

- 1) Penchuk, A., and S. Croopnick, "Digital Autopilot for Thrust Vector Control of the Orbital Maneuvering System," *Journal of Guidance, Control, and Dynamics*, Vol. 6, No. 6, pp. 436-441, November-December 1983.
- 2) Hattis, P., "Qualitative Differences Between Shuttle On-Orbit and Transition Control," *Journal of Guidance, Control, and Dynamics*, Vol. 7, No. 1, pp. 4-8, January-February 1984.
- 3) Kenneth J. Cox and Philip D. Hattis, "Shuttle Orbit Flight Control Design Lessons: Direction for Space Station," *Proceedings of the IEEE*, Vol. 75, No. 3, pp. 336-355, March 1987

- 4) Zimpfer, D., S. Tuohy and P. Kackmar, "Autonomous Rendezvous, Capture and In-Space Assembly: Past, Present and Future", AIAA Space Exploration Conference, Orlando, FL, January 30 - February 1, 2005.
- 5) Zimpfer, D. and Spehar, P., "STS-71 Shuttle/Mir GNC Mission Overview", AAS Space Flight Mechanics Meeting, Austin, TX, February 12-15, 1996.
- 6) Kachmar, P., Space Shuttle GN&C Equation Document, Rendezvous Terminal Phase Automatic Braking Sequencing and Targeting, Draper Laboratory Report, July, 1973.
- 7) Kachmar, P., "Apollo and Space Shuttle On-board Navigation Systems: Application of Kalman Filtering Techniques", Institute of Navigation 58<sup>th</sup> Annual Meeting, Albuquerque, NM, June 24-26, 2002.
- 8) Clark, F., "Laser-Based Relative Navigation and Guidance for Space Shuttle Proximity Operations", AAS Guidance and Control Conference, Breckenridge, CO, February 5-9, 2003.
- 9) "On-Orbit Flight Control Algorithm Description," Draper Laboratory, CSDL-R-0881, May 1975.
- 10) Hattis, P. "Boolean Algebraic Implementation of the Shuttle On-Orbit Autopilot Jet-Selection Algorithm," Draper Laboratory, CSDL-C-5188, March 1979.
- 11) Sackett, L., and C. B. Kirchwey, "Dynamic Interaction of the Shuttle On-Orbit Flight Control System with Deployed Flexible Payloads," Presented at the AIAA Guidance and Control Conference, Draper Laboratory, CSDL-P-1581, June 1982, Paper AIAA-82-2178, in *Proc AIAA Guidance and Control Conf.*, pp. 232-245, August 1982.
- 12) Zimpfer, D., C. Kirchwey, D. Hanson, M. Jackson, N. Smith, "Shuttle Stability and Control of the STS-71 Shuttle/Mir Mated Configuration," Presented at AAS/AIAA Space Flight Mechanics Meeting, Austin, TX, Paper AAS 96-131, February 12-15, 1996.
- 13) Jackson, M., D. Zimpfer, J. Lepanto, "Identification of Shuttle/Mir Structural Dynamics for Notch Filter Tuning," Presented at AAS/AIAA Space Flight Mechanics Meeting, Austin, TX, Paper AAS 96-132, February 12-15, 1996.
- 14) Sackett, M., C. B. Kirchwey, M. C. Johnson, R. D. Barrington, "Flight Control Dynamics and Structural Interaction on the Second Hubble Space Telescope Servicing Mission," Draper Laboratory, CSDL-P-3595, August 1997, Paper AAS 97-730, *Astrodynamics 1997, Advances in the Astronautical Sciences, Vol. 97*, 1998.
- 15) Pierson, W. L., and Unger, C., "Flight Control Stability and Trim Analysis Techniques," Presented at AAS/AIAA Astrodynamics Conference, San Diego, Ca., AIAA-82-1603, August 9-11, 1982.
- 16) McWhorter, L. B., and Reed, M., "Space Shuttle Entry Digital Autopilot," NASA/SP-2010-3408, February 2010





# SPACE SHUTTLE GN&C DEVELOPMENT HISTORY AND EVOLUTION

John Ruppert/NASA

Doug Zimpfer/Draper Lab

Phil Hattis/Draper Lab

Don Gavert/Boeing Retired

AIAA Space 2011 Conference

September 2011





# Overview



- GN&C Background
- GN&C Development
- GN&C Evolution
- Mission Milestones/Accomplishments
- Lessons Learned
- Summary



- Shuttle GN&C Developed through MODE team approach
  - Multiple organizations co-developing systems and operations
- Team Included
  - NASA – GN&C MODE Team Leads
  - Rockwell International/Boeing – Prime Contractor
  - Draper Laboratory – Orbit GNC Development/BFS
  - IBM – Flight Software
  - Honeywell, McDonnell Douglas, Lockheed Martin

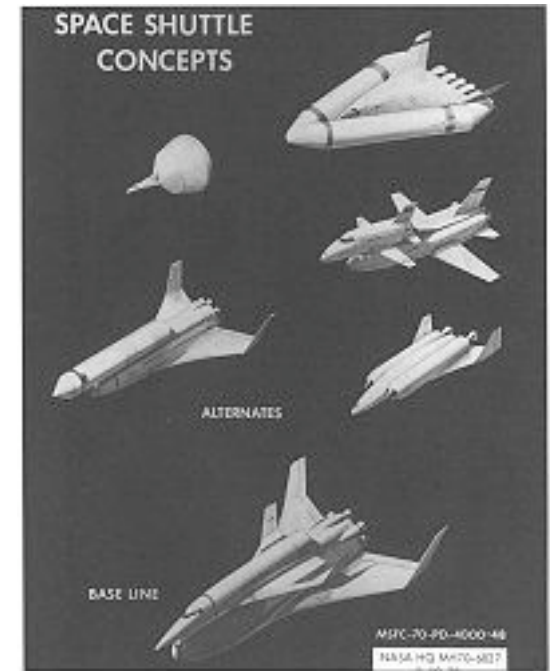

## Typical Flight Profile

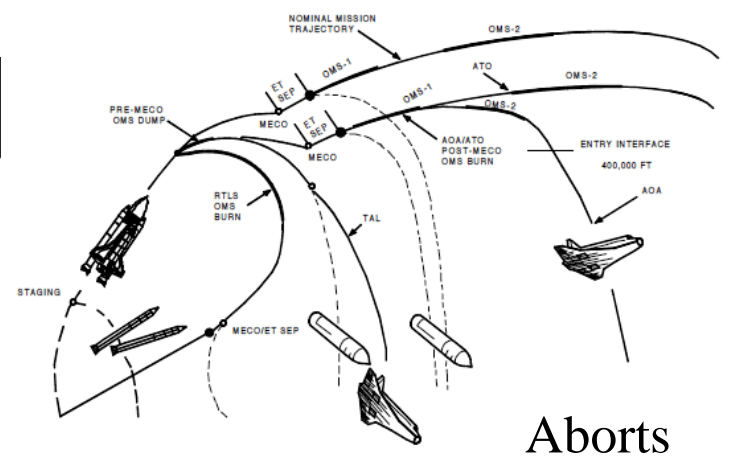
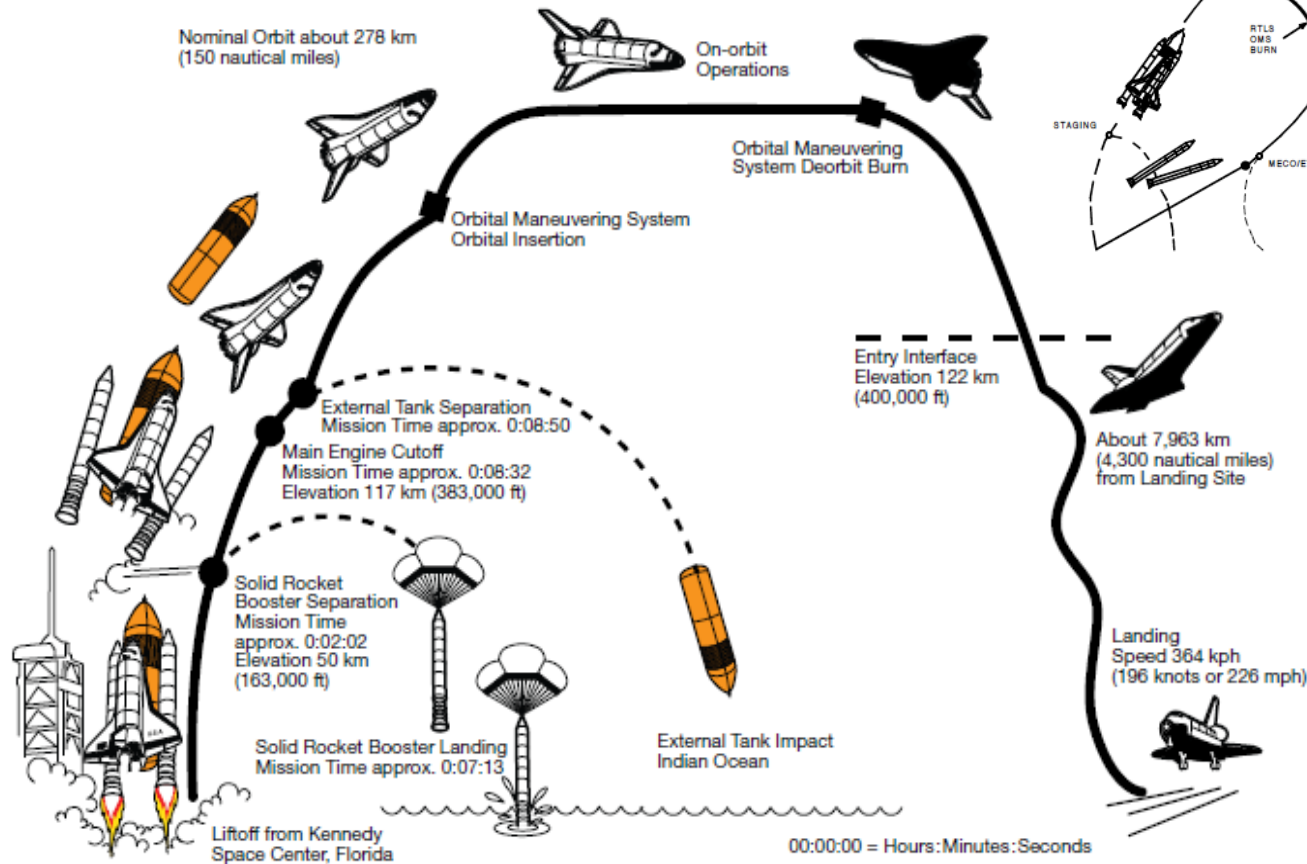

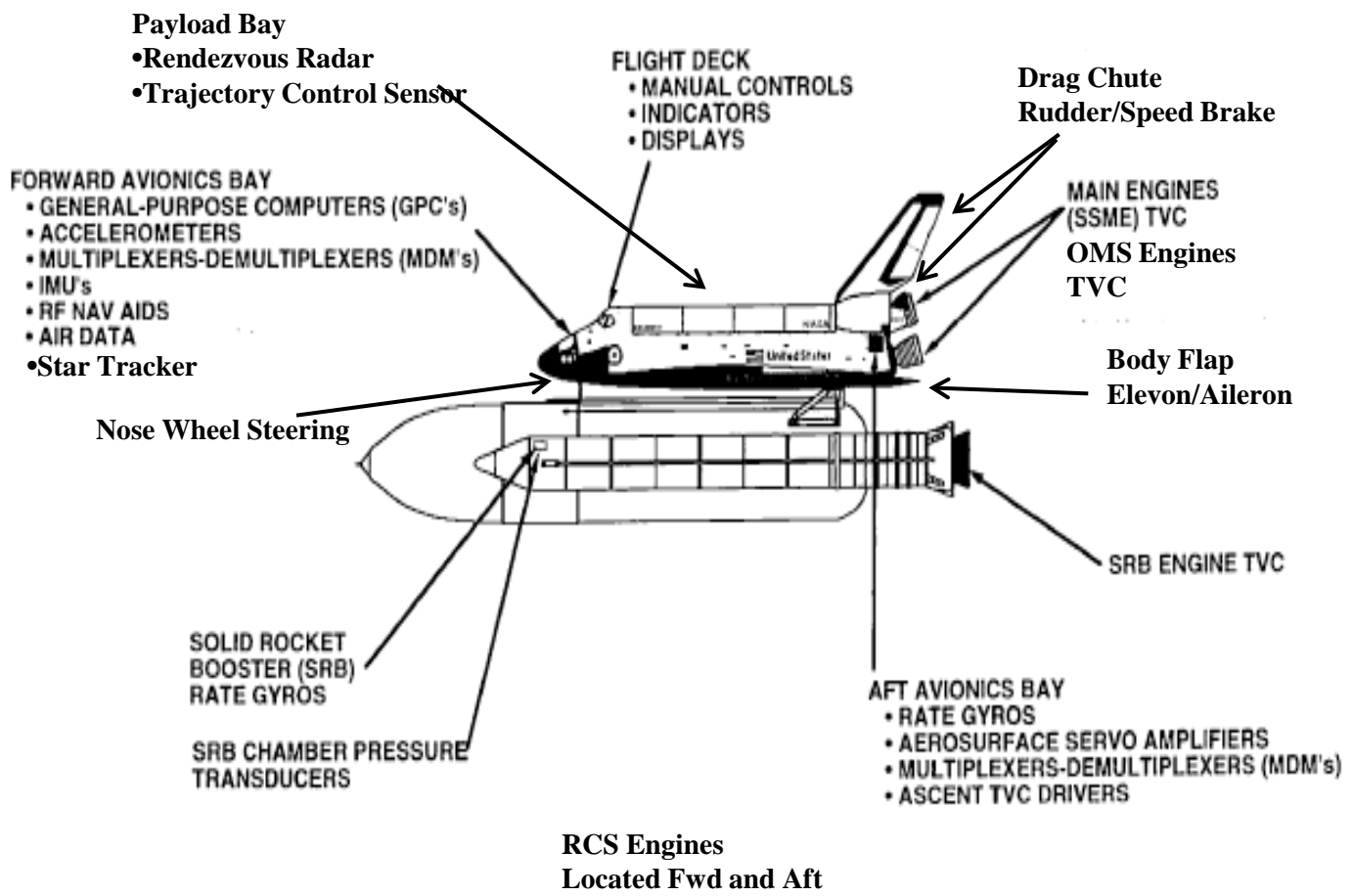

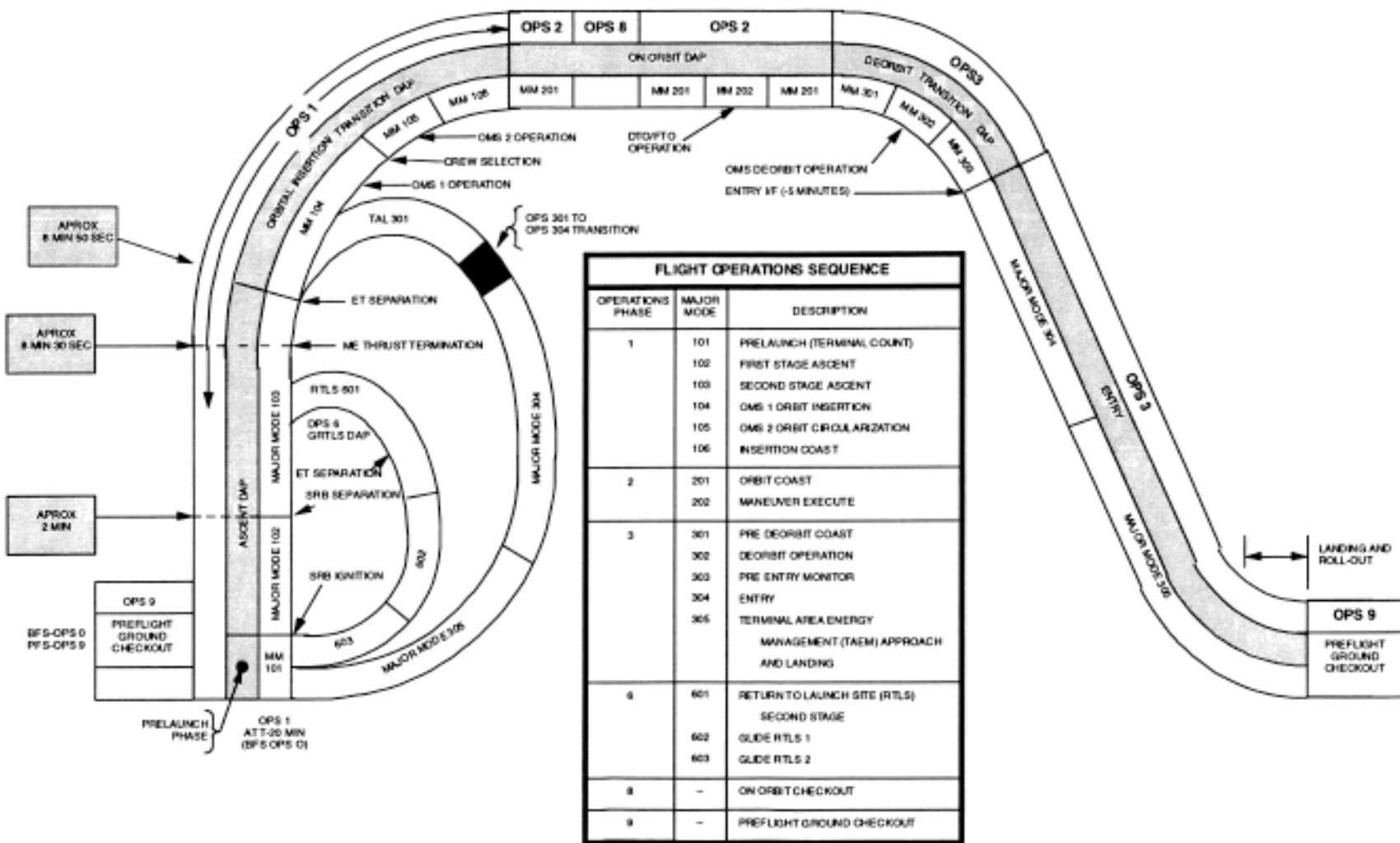

- Primary design drivers: Crew safety and Mission success
- FO/FS architecture
- Manual/Auto modes
- Independent backup flight system
- Digital fly-by-wire controller
- Abort capability
- On Orbit “fine” pointing control
- Payload deployment, rendezvous and proximity operations, capture of free flyers with remote manipulator system
- Latter objective: ISS assembly and ISS stack control

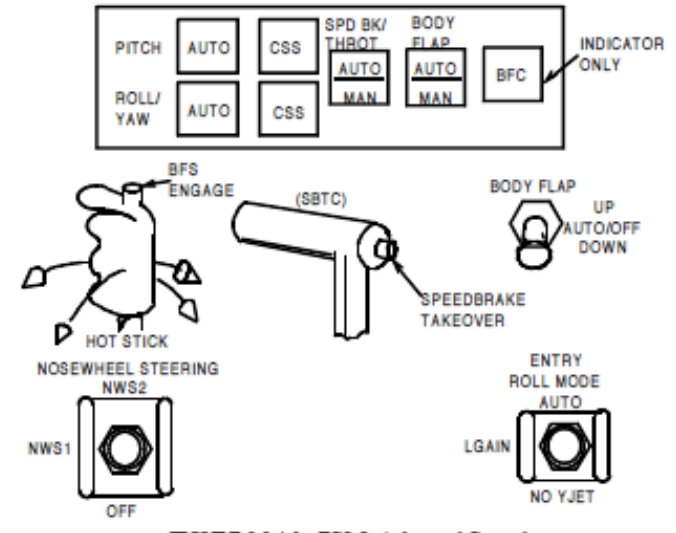

# GN&C Development Objectives

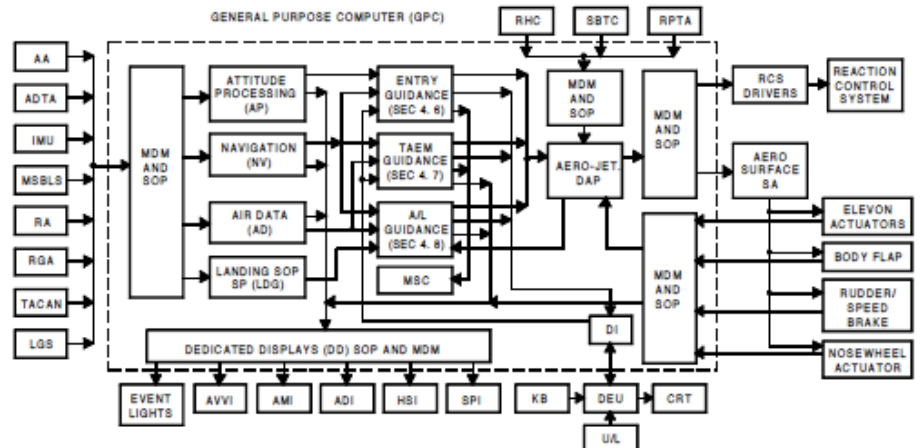
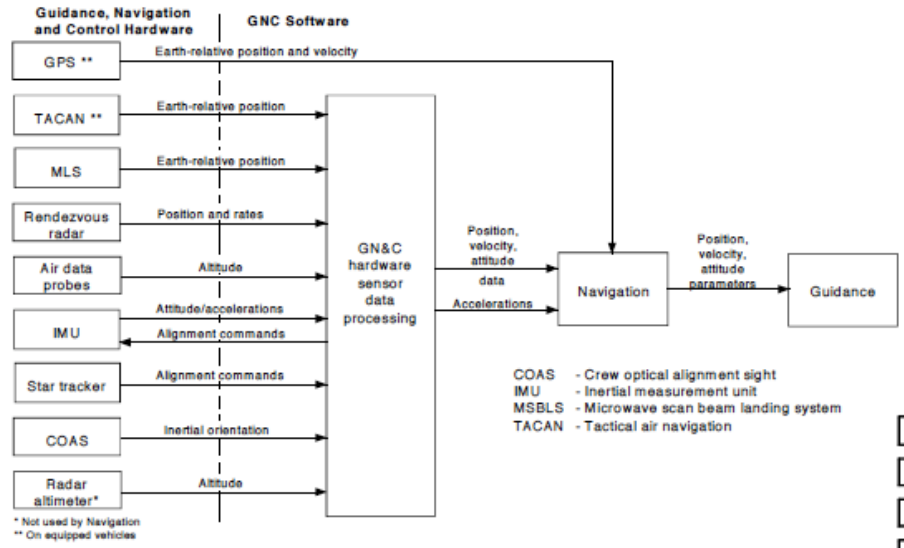

SYMBOL	DESCRIPTION	SYMBOL	DESCRIPTION
AA	ACCELEROMETER ASSEMBLY	KB	KEYBOARD
ADI	ATTITUDE DIRECTION INDICATOR	LGS	LANDING GEAR SWITCHES
ADTA	AIR DATA TRANSDUCER	MSBLS	MICROWAVE SCAN BEAM LANDING SYSTEM
AMI	ALPHA-MACH INDICATOR	RA	RADAR ALTIMETER
AVVI	ALTITUDE - VERTICAL VELOCITY INDICATOR	RGA	RATE GYRO ASSEMBLY
CRT	CATHODE RAY TUBE	RHC	TWO-AXIS ROTATIONAL HAND CONTROLLER
DEU	DISPLAY ELECTRONICS UNIT	RPTA	RUDDER PEDAL TRANSDUCER ASSEMBLY
DI	DISPLAY INTERFACE	SA	SERVO AMPLIFIERS
MSC	MODING, SEQUENCE, AND CONTROL	SBTC	SPEED BRAKE THRUST CONTROLLER
HSI	HORIZONTAL SITUATION INDICATOR	SPI	SURFACE POSITION INDICATOR
IMU	INERTIAL MEASUREMENT UNIT	TACAN	TACTICAL AIR NAVIGATION
		U/L	UPLINK PROCESSOR

(Note: OPS 3 descent guidance principal function references utilized for illustrative purposes)



- Primary function to deliver vehicle to orbit
  - Meet insertion criteria
  - Accommodate various abort scenarios
- Significant vehicle constraints
  - 1) no re-contact with launch pad;
  - 2) maintain aerodynamic loads with structural capability;
  - 3) meet specific attitude and rates at SRB separation;
  - 4) maintain attitude within thermal attitude constraint;
  - 5) maintain axial acceleration below 3 g's;
  - 6) meet specific attitude and rates at ET separation;
  - 7) meet ET disposal criteria;
  - 8) maintain RTLS trajectory within fly back range and dynamic pressure constraints;
  - 9) RTLS MECO mass constraint;
  - 10) provide modal suppression and/or attenuation as required for dynamic stability

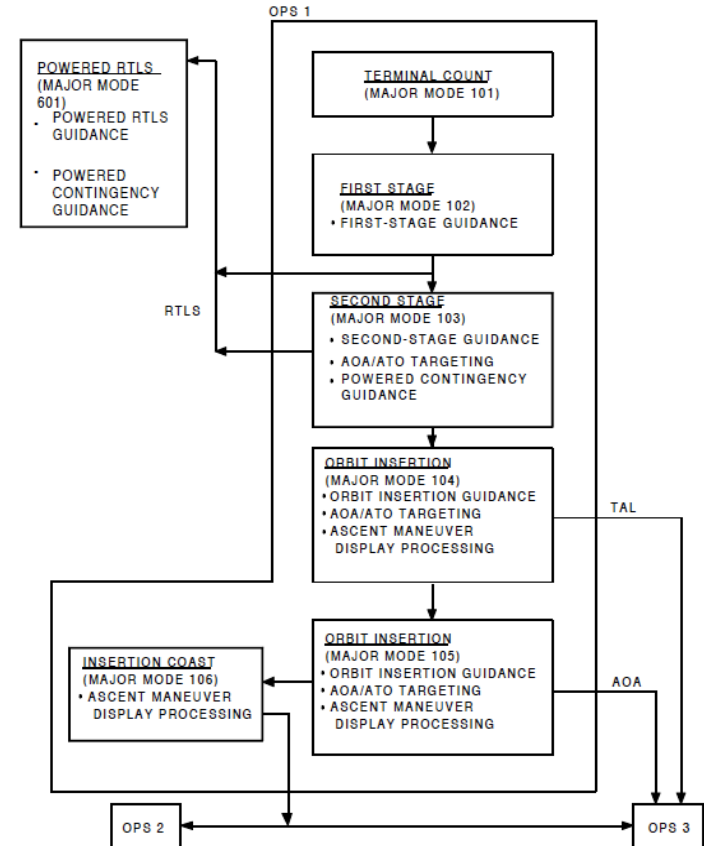

- Development significantly leveraged Apollo GN&C development
  - Completed via a Track Task to NASA/Draper Lab
- Primary Functions
  - Insertion/Deorbit
  - Attitude Control/Pointing
  - Rendezvous and Capture
  - Orbital Maneuvers
- Key Development Items
  - RCS thruster control
  - TVC control for burns
  - Relative Navigation for Rendezvous
  - Stability with deployed payloads (RMS and directly mated)
  - ET Separation

## Shuttle Phase Plane Control Law

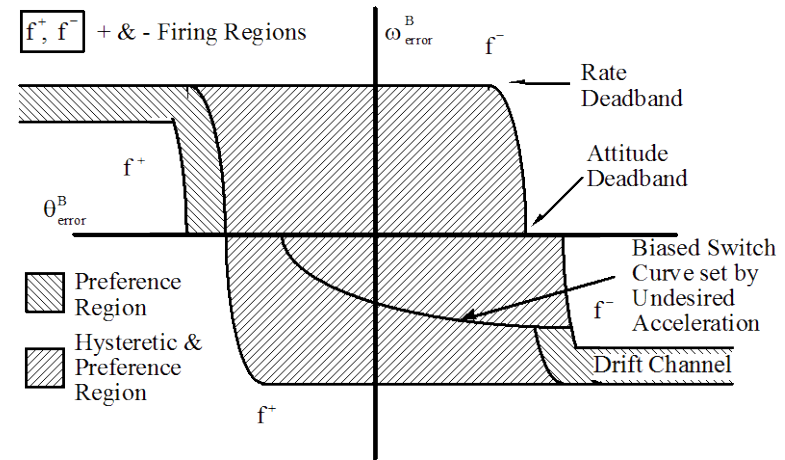

## Shuttle Relative Navigation Filter

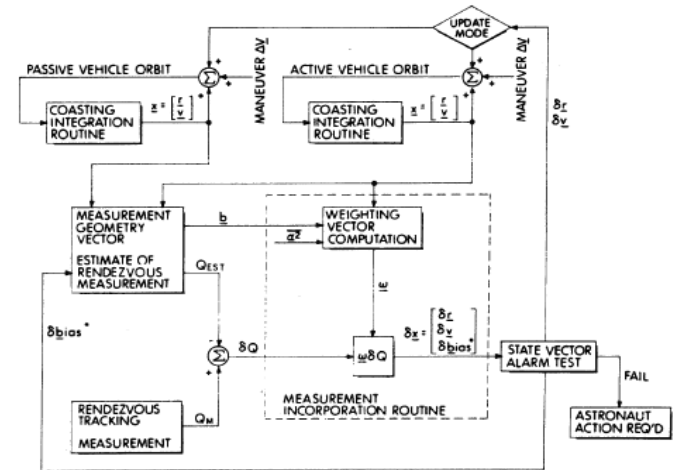

- Entry Development Team
  - NASA, Rockwell (Boeing), Sperry (HI), MD(Boeing)
- Primary functions
  - Thermal management
  - Energy management
  - Approach and Landing
  - Accommodate abort landings
- Key Development Items
  - A/L & Energy Mgmt Guidance
  - Speed brake Mgmt
  - Auto/Manual flight control
  - Aero robustness
  - PIO robustness
  - Bending filters
- Significant flight test through ALT flights

## Heading Alignment Cone

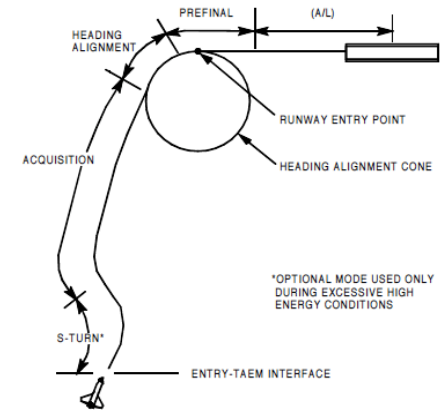

## Approach and Landing

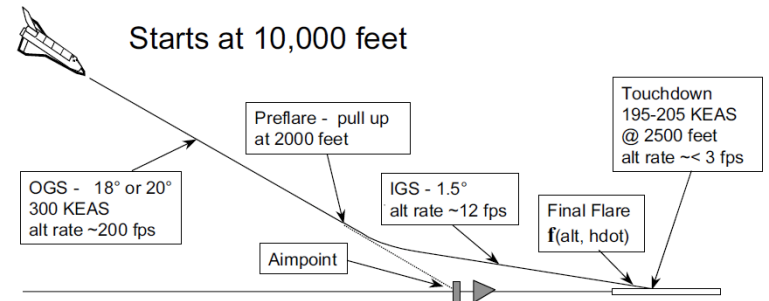

- Aborts
  - Automation of Transoceanic Abort Landing (TAL)
  - Addition of Contingency Abort (post Challenger accident)
    - East Coast Abort Landing (ECAL): intact east coast emergency landing
    - In-flight Crew Escape System (ICES): bailout mode
      - Modified autopilot to hold angle of attack at 15 degrees

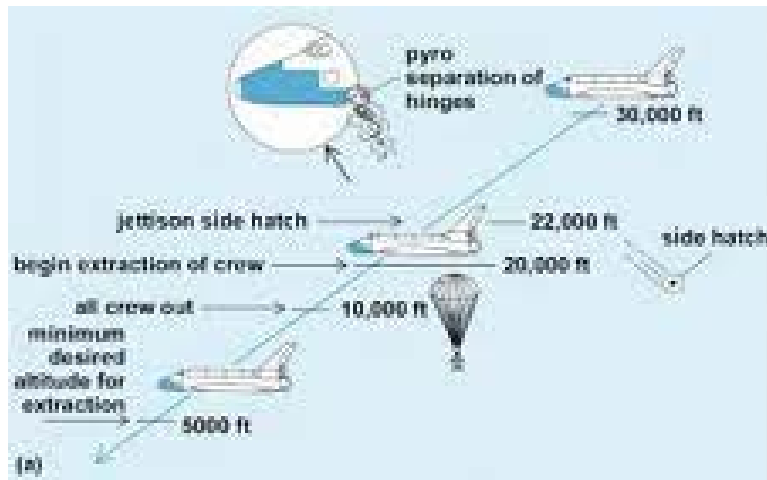

- Entry Flight Control

- Active nosewheel steering
- Addition of drag chute
- “Smart” speedbrake FSW modifications for HAC wind energy management
- Implementation of Optional TAEM Targeting (OTT); allowed HAC turns greater than 180 degrees
- Wraparound DAP modification: reduce RCS propellant usage, optimized aero control with limited or no yaw RCS capability (no Yaw Jet mode)
- Multitude of modifications to gain schedules, filters, and effector on/off transition logic
- Addition of GPS

- Orbit flight control system upgrades for ISS assembly addressed issues with operability, controllability, stability and induced loads

Title	Function	Description
Alt PRCS	Loads	Implemented load efficient pulsing of the PRCS jets to enable control with reduced structural loads.
Minimum Angle Jet Selection	Control	Improved control by aligning resultant acceleration with desired acceleration
Notch Filters	Stability	Provided stability by minimizing structurally induced feedback in the rate estimate
Reboost	Operability, Loads	Provided an automated reboost operation within structural loads
Feed Forward	Control, Stability	Improved performance when using the Notch Filters
Onboard Mass Props	Operability	Calculated thruster accelerations onboard to simplify uplink of the vehicle configuration

- Development of the Trajectory Control Sensor (TCS)
- Utilization of hand held LIDARS
- Development of the Rendezvous and Proximity Operations Program (RPOP)

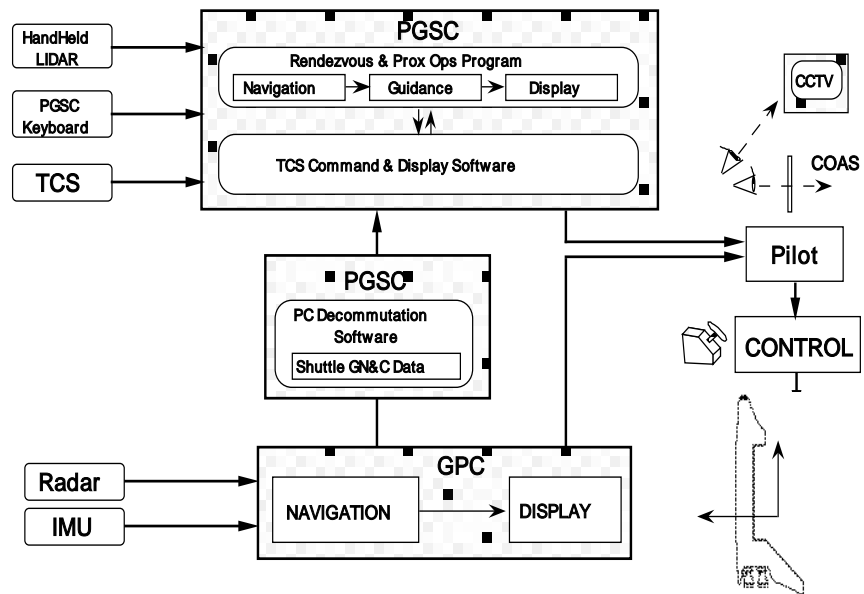
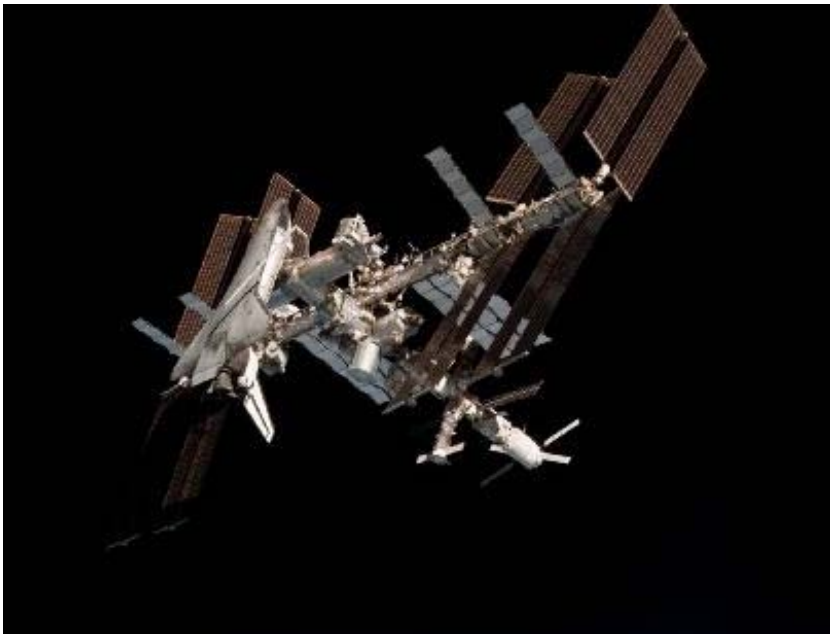

ALT Flight Test



STS-1 Launch



Orbiter/MIR Docked



STS-61 Hubble Capture



Shuttle/ISS Control



STS-49 Drag Chute







# GN&C Lessons Learned



- **Program objectives will evolve:** accommodate GN&C evolution through modular architecture and implementation
- **Flight Test program:** without a proper flight test program reaching the goal of “operational” is slow and costly
- **Early evaluation of flight software sizing:** expected software functionality exceeded capabilities and a software scrub was conducted prior to first flight. Current programs need to be aware that software functionality needs to be appropriately managed within the capabilities of the processing elements.
- **Early prototypes, development and integration:** Over the course of the Shuttle development significant capabilities were developed to allow early prototype and simulation of new GN&C capabilities. These early efforts have been essential to the successful implementation of new capabilities into the vehicle
- **Independently designed primary and backup flight systems:** the tremendous effort to validate and verify Orbiter control during the transition from PFS to BFS. It was not as seamless as first envisioned.





# Summary



- Thirty years of successful flight
- First reusable space transportation system
- First all Fly-by-Wire space transportation control system
- Operational flexibility of GN&C demonstrated through thirty years of expanded mission requirements
- Created an algorithm, simulation, and analysis library that continues to be leveraged by GN&C developers today
- Shuttle provided a “proving ground” for new technologies and capabilities that can be utilized on future spacecraft

